

21º PASSO | PASS | PASO

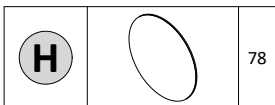

Colar tapa furo adesivo nos parafusos das molduras
 Attach adhesive hole plug to frame screws
 Pegue la tapa del orificio adhesivo en los tornillos del marco

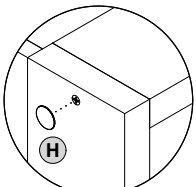

Colar tapa furo adesivo nos parafusos externos
 Attach adhesive hole plug to external screws
 Pegue la tapa del orificio adhesivo en los tornillos externos

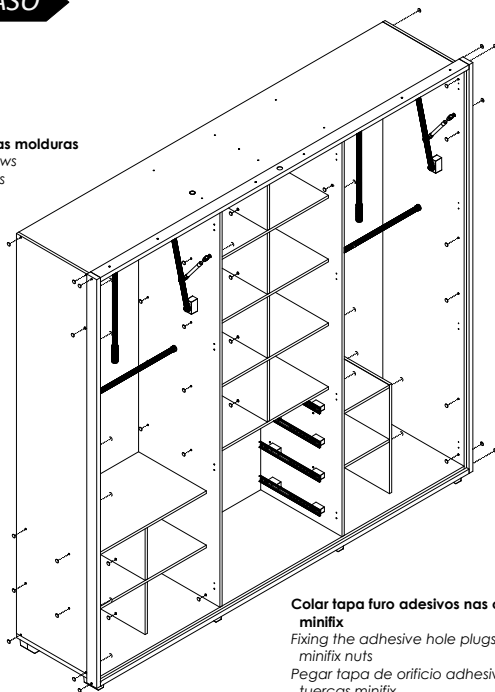
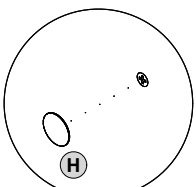

Colar tapa furo adesivos nos parafusos internos
 Attach adhesive hole plugs to the internal screws
 Pegar pegatinas en los agujeros tornillos internos

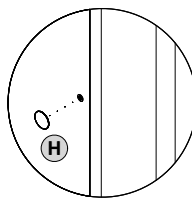

Colar tapa furo adesivos nas castanhas minifix
 Fixing the adhesive hole plugs to the minifix nuts
 Pegar tapa de orificio adhesivo en tuercas minifix

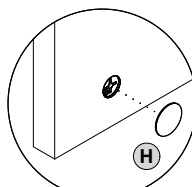

PESO SUPORTADO | SUPPORTED WEIGHT | PESO SOPORTADO

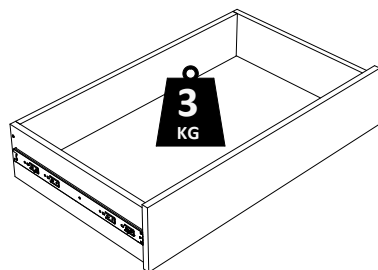
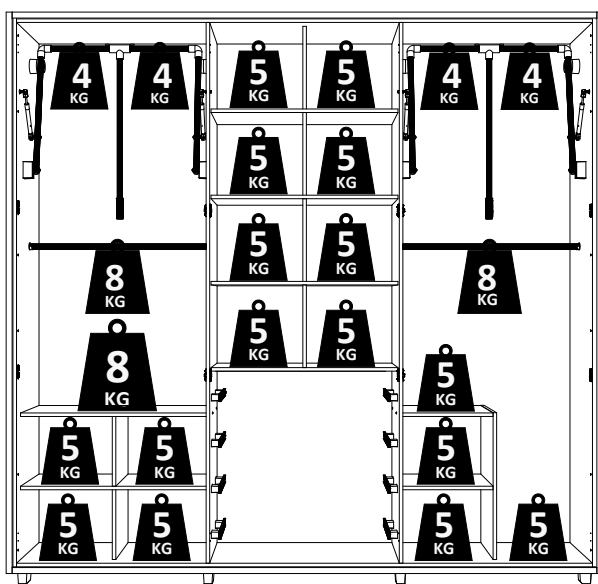

CUIDADOS ESPECIAIS | SPECIAL CARES | CUIDADOS ESPECIALES:

LIMPEZA MADEIRA: Pano limpo umedecido em água e sabão neutro - **BRILHO:** Flanela seca
CLEANING: Clean cloth humidified in water and neutral soap - **SHINE:** Dry flannel
LIMPIEZA: Tela limpia humedecida en la agua y el jabón neutro - **BRILLO:** Franela seca

Data última atualização
 Last update
 Fecha de última actualización
30.03.2025

166 - GUARDA-ROUPA MIRÓ
WARDROBE | ROPERO



ESQUEMA DE MONTAGEM | ASSEMBLY INSTRUCTIONS | ESQUEMA DE MONTAJE

ASPECTO FINAL | FINAL ASPECT



ACESSE AQUI

ESPAZO

É tudo.
 E um pouco mais.

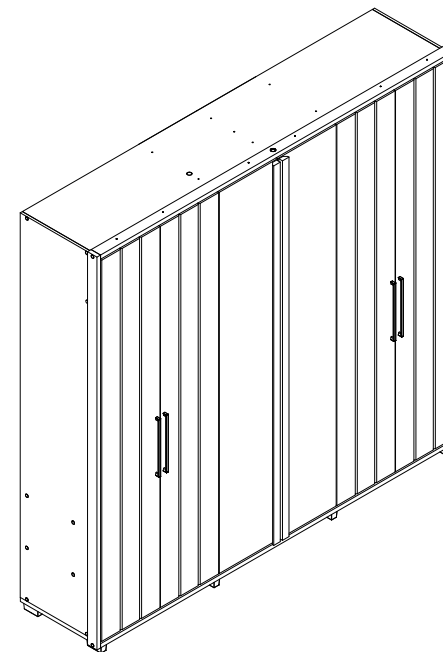

Pessoas necessárias para montagem
 People required for assembly
 Personas necesarias para el montaje



Ferramentas necessárias para montagem (não fornecidas)
 Tools required for assembly (not provided)

Herramientas necesarias para el montaje. (no proporcionado)

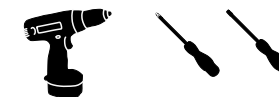

Parafusadeira ou chave de fenda e philips
 Screwdriver or Phillips screwdriver
 Destornillador o destornillador y Philips



Martelo | Hammer | Martillo



Trena | Measuring tape | Cinta métrica

INSTRUÇÕES | INSTRUCTIONS | INSTRUCCIONES

- Prepare a montagem do móvel próximo ao local que ele ficará definitivamente e evite deslocá-lo depois de montado;
 - Forre o chão com papelão ou similar e utilize a isomanta que vem entre as peças para evitar o contato entre elas durante a montagem;
 - Monte o móvel obedecendo a ordem numérica da **seqüência de montagem (S.M.)**, identificando as peças pelo **código de peça (C.P.)** carimbado na mesma.

- Prepare the assembly of the close piece of furniture to the place that it will be definitively and avoid to move after done. Will be definitively and avoid to move after done;
 - Cover the ground with cardboard or similar and use the "isomanta" that it comes among the pieces to avoid the contact among them during the assembly;
 - Set up the piece of furniture obeying the numeric order of the **assembly sequence (S.M.)**, identifying the pieces by **code of piece (C.P.)** stamped in the same.

- Prepare la montaje del mobiliario proximo al lugar que estará definitivamente y evite mover después de hecho;
 - Tape la tierra con el cartón o similar y use la "isomanta" que viene entre las piezas para evitar el contacto entre ellos durante la montaje;
 - Monte el mobiliario obedeciendo la orden numérica de la **sucesión de montaje (S.M.)**, identificando las piezas por el **código de piezas (C.P.)** de la misma estampado en esta.



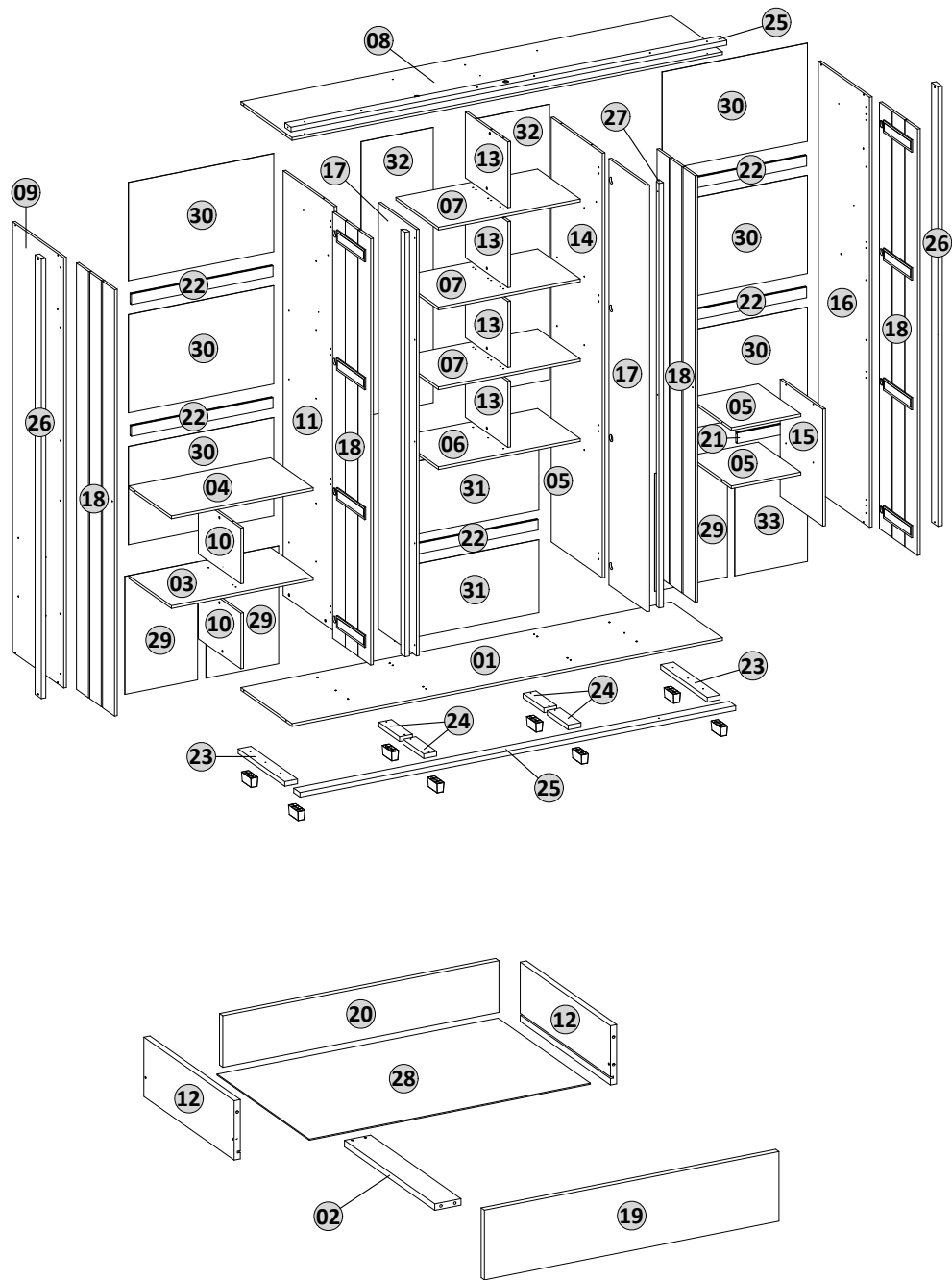

Atendimento ao consumidor | Attendance to the consumer | Asistencia al consumidor
 tel +55 43 3303 1800
 madetec@madetec.com.br

Madedec Móveis Ltda.
 Rua Rouxinol 5205 | Parque Industrial IV
 CEP 86706-418 | Araçongas | PR | Brasil
 www.madetec.com.br

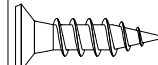

PEÇAS
PIECES
PIEZAS

E		32	G		64	X		16
----------	--	----	----------	--	----	----------	--	----

S.M. C.P.

01	18
02	18
03	18
04	18

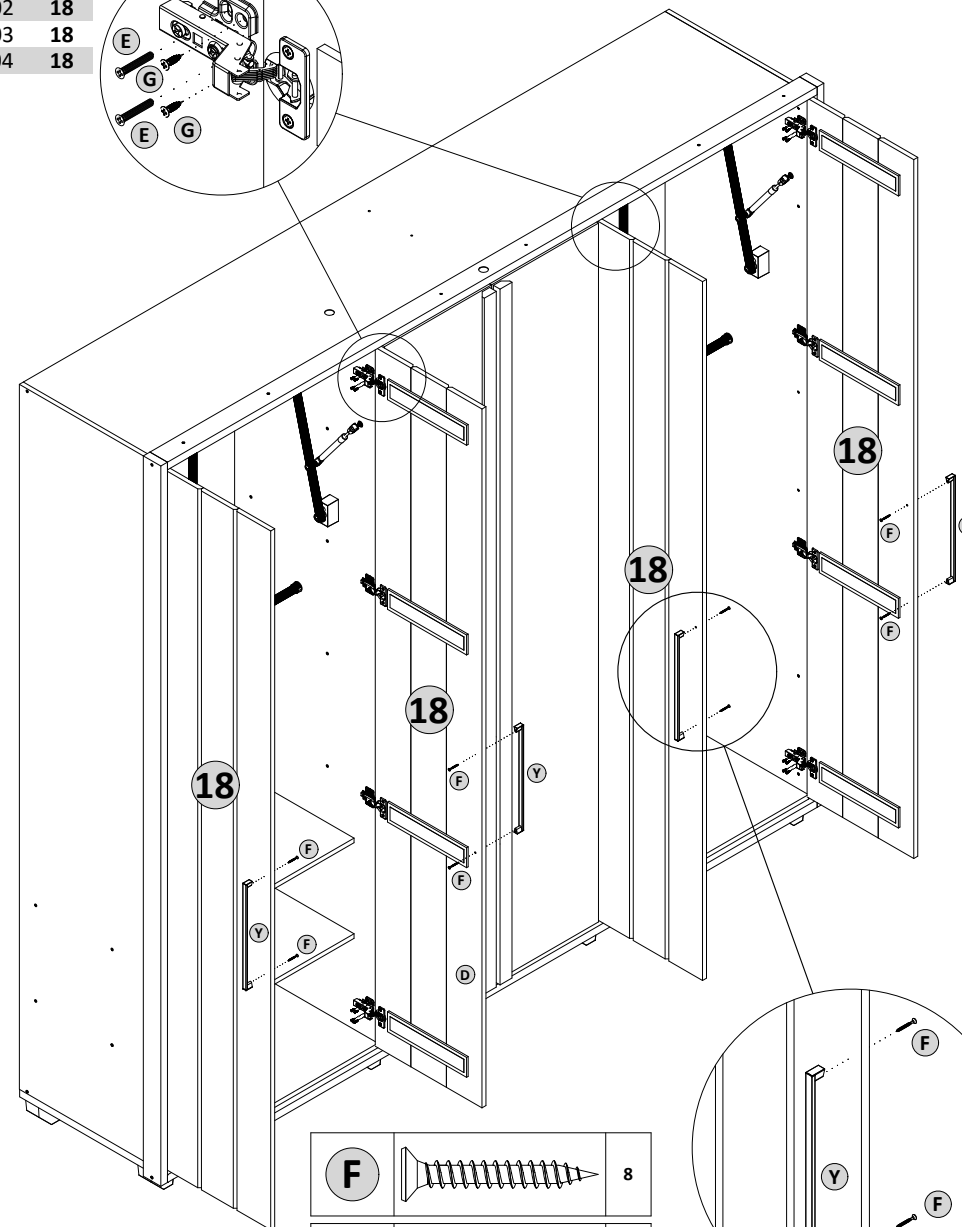
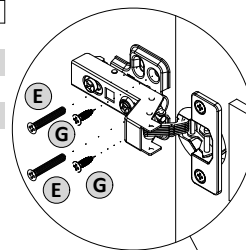

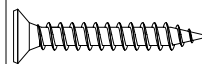
F		8
----------	---	---

Y		4
----------	---	---

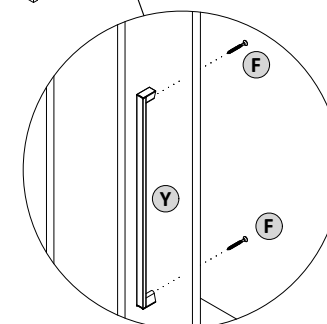

PEÇAS
PIECES
PIEZAS

S.M.	C.P.
01	17
02	27
03	17
04	27

E



X



16

D

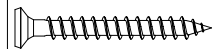

FIXANDO AS PORTAS
FIXING THE DOORS
FIJANDO LAS PUERTAS

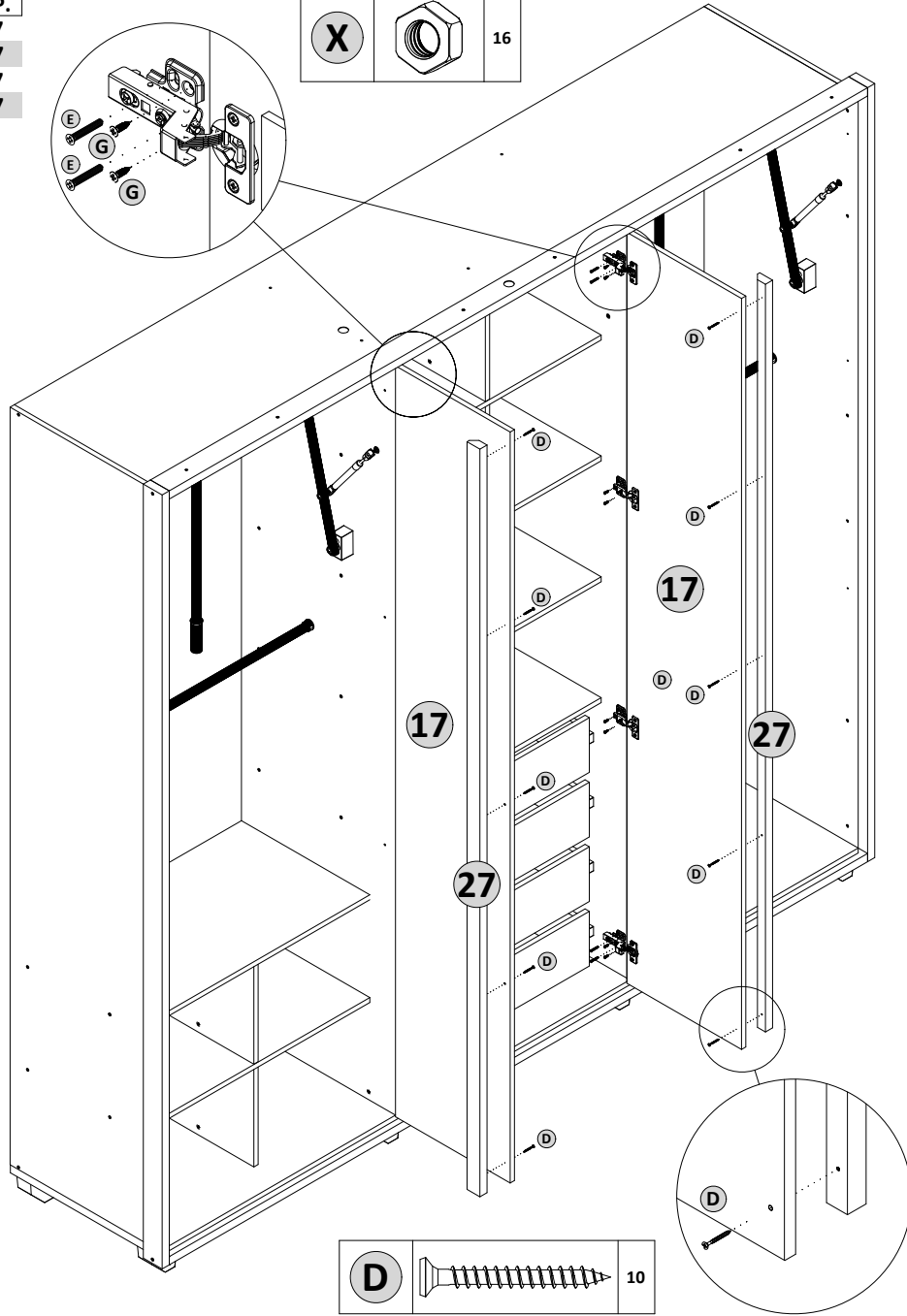

REF.:	CÓDIGO DA PEÇA PART CODE CÓDIGO DE PIEZA		DESCRICÃO DA PEÇA PART DESCRIPTION DESCRIPCIÓN DE PIEZA	MATERIA PRIMA FEEDSTOCK	DIMENSÕES DIMENSIONS DIMENSIONES	QUANT. AMOUNT CANTIDAD
	CINAMOMO	CINAMOMO OFF WHITE				
01	204252.037	204252.037	Base Base	MDF	2418 x 540 x 15	1
02	204223.009	204223.009	Travessa da gaveta Drawer crossbar Bandeja do cação	MDF	415 x 62 x 15	4
03	204253.037	204253.037	Prateleira inferior esquerda Bottom left shelf Estante inferior esquerda	MDF	796 x 450 x 15	1
04	204254.037	204254.037	Prateleira superior esquerda Top left shelf Estante superior esquerda	MDF	796 x 450 x 15	1
05	204255.037	204255.037	Prateleira inferior direita Bottom right shelf Estante inferior direita	MDF	449 x 390 x 15	2
06	204256.037	204256.037	Prateleira inf da colméia Bottom shelf of the hive Estante inferior colmena	MDF	796 x 450 x 15	1
07	204257.037	204257.037	Prateleira sup da colméia Top shelf of the hive Estante superior colmena	MDF	796 x 450 x 15	3
08	204258.037	204258.037	Chapéu Top panel Panel superior	MDF	2418 x 540 x 15	1
09	204259.037	204259.037	Lateral esquerda Left side panel Panel lateral izquierdo	MDF	2230 x 540 x 15	1
10	204260.037	204260.037	Divisão esquerda menor Smaller left division División izquierda menor	MDF	449 x 297 x 15	2
11	204261.037	204261.037	Divisão esquerda maior Larger left division División izquierda maior	MDF	2270 x 540 x 15	1
12	204014.037	204014.037	Lateral de gaveta Drawer side panel Panel lateral del cajón	MDF	415 x 138 x 15	8
13	204262.037	204262.037	Divisão central Central division División central	MDF	449 x 352 x 15	4
14	204263.037	204263.037	Divisão direita maior Larger right division División derecha maior	MDF	2270 x 540 x 15	1
15	204264.037	204264.037	Divisão direita menor Smaller right division División derecha menor	MDF	625 x 450 x 15	1
16	204265.037	204265.037	Lateral direita Right side panel Panel lateral derecho	MDF	2300 x 540 x 15	1
17	204266.037	204266.026	Porta Door Puerta	MDF	2280 x 402 x 15	2
18	204267.037	204267.026	Porta lateral chanfrada Beveled side door Puerta lateral chanfrada	MDF	2280 x 402 x 15	4
19	204272.037	204272.037	Fronte de gaveta Drawer front panel Panel frontal del cajón	MDF	723 x 166 x 15	4
20	204273.037	204273.037	Contra fundo de gaveta Drawer back panel Panel trasero del cajón	MDF	677 x 120 x 15	4
21	204274.037	204274.037	Perfil H menor Smaller H profile Perfil H menor	MDF	390 x 56 x 15	1
22	204275.037	204275.039	Perfil H maior Larger H profile Perfil H maior	MDF	492 x 56 x 15	5
23	207242.037	207242.037	Rodapé lateral Side support of the base Soporte lateral de la base	MDF	492 x 72 x 25	2
24	204243.009	204243.009	Rodapé central Central base support Soporte base central	MDF	220 x 72 x 25	4
25	204276.037	204276.037	Moldura inferior/superior Bottom/Top Frame Bisel inferior/superior	MDF	2448 x 66 x 25	2
26	204245.037	204245.037	Moldura lateral Side frame Marco lateral	MDF	2350 x 66 x 25	2
27	204277.037	204277.037	Puxador Handle Tirador	MDF	2270 x 45 x 25	2
28	204278.037	204278.037	Fundo de gaveta Drawer bottom Fondo del cajón	MDF	690 x 420 x 3	4
29	204279.037	204279.037	Fundo lateral inf esq/cent Bottom lateral rear panel Panel trasero lateral inf	MDF	630 x 406 x 3	3
30	204280.037	204280.037	Fundo superior esquerdo Upper left rear panel Panel trasero superior izquierdo	MDF	814 x 525 x 3	6
31	204281.037	204281.037	Fundo central inferior Lower central rear panel Panel trasero central inferior	MDF	810 x 389 x 3	2
32	204282.037	204282.037	Fundo central superior Upper central rear panel Panel trasero central superior	MDF	1472 x 405 x 3	2
33	204283.037	204283.037	Fundo lateral inf dir Bottom right side rear panel Panel trasero lateral inferior	MDF	585 x 408 x 3	1

LEGENDA DAS CORES | COLOR LEGEND | LEYENDA DE COLOR

009 - SEM PINTURA | UNPAINTED | SIN PINTAR

026 - OFF WHITE

037 - CINAMOMO

039 - CUMARU

040 - OPALA

ACESSÓRIOS | ACCESSORIES

PARAFUSOS | Screw | Tornillo

CÓDIGO | CODE

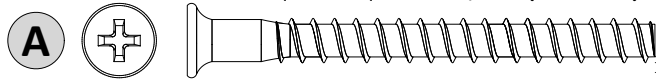

Parafuso | Screw | Tornillo 5,0x50 (Estrutural)

42x 102100045

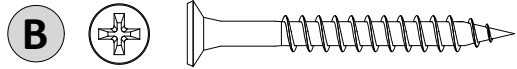

Parafuso | Screw | Tornillo 4,5 x 40

16x 102100001

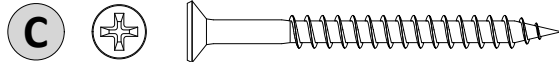

Parafuso | Screw | Tornillo 3,5x40

24x 102100012

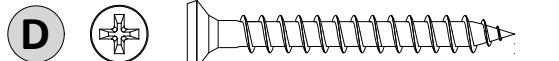

Parafuso | Screw | Tornillo 4,0x35

38x 102100038



Parafuso | Screw | Tornillo 4,0x25

16x 102100007

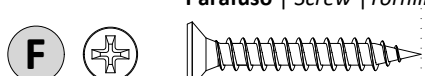

Parafuso | Screw | Tornillo 3,5x25

8x 102100004

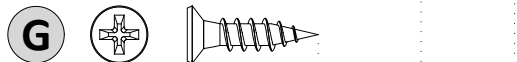

Parafuso | Screw | Tornillo 3,5x14

256x 102100003

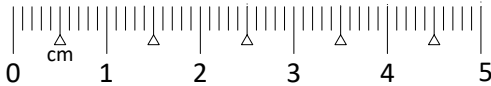

RELAÇÃO DE COR DOS ACESSÓRIOS

Color ratio of accessories | Relación de color de los accesorios

LETRA LETTER	DESCRIÇÃO DESCRIPTION DESCRIPCIÓN	MATÉRIA PRIMA FEEDSTOCK	COR COLOR	QUANT. AMOUNT CANTIDAD			CÓDIGO CODE
				CINAMOMO	CINAMOMO OFF WHITE	CUMARU OPALA	
H	Tapa furo adesivo 18mm Adhesive hole cover 18mm Tapa agujero adhesivo 18mm	Papel Paper	Cinamomo	110	110		102080216
			Cumaru			110	102080286
i	Giz p/ correção Touch-up chalk Tiza correctora	Cera Wax	Cinamomo	1	1		102140023
			Off white		1		102140008
			Cumaru			1	102140026
			Opala			1	102140025

17º PASSO | PASS | PASO

MONTAGEM DAS PORTAS LISAS

ASSEMBLY OF SMOOTH DOORS

MONTAJE DE PUERTAS LISAS

F		16
V		4
W		4

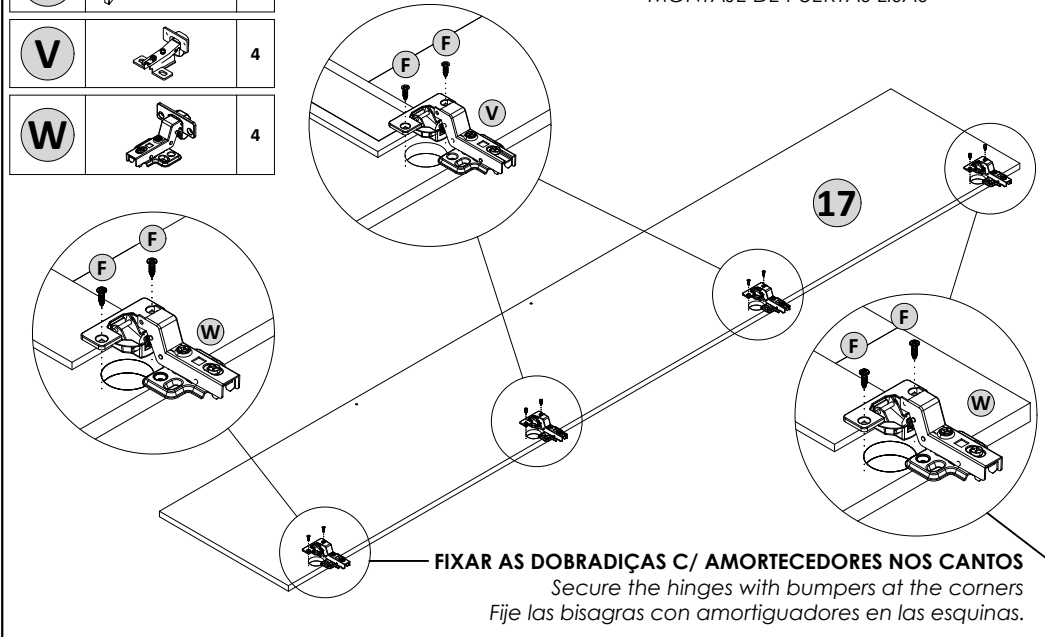

FIXAR AS DOBRADIÇAS C/ AMORTECEDORES NOS CANTOS

Secure the hinges with bumpers at the corners
Fije las bisagras con amortiguadores en las esquinas.

18º PASSO | PASS | PASO

MONTAGEM PORTA CENTRAL (CHANFRADA)

CENTRAL DOOR ASSEMBLY (BEVELED)

CONJUNTO DE PUERTA CENTRAL (CHANFRADA)

F		8
V		2
W		2

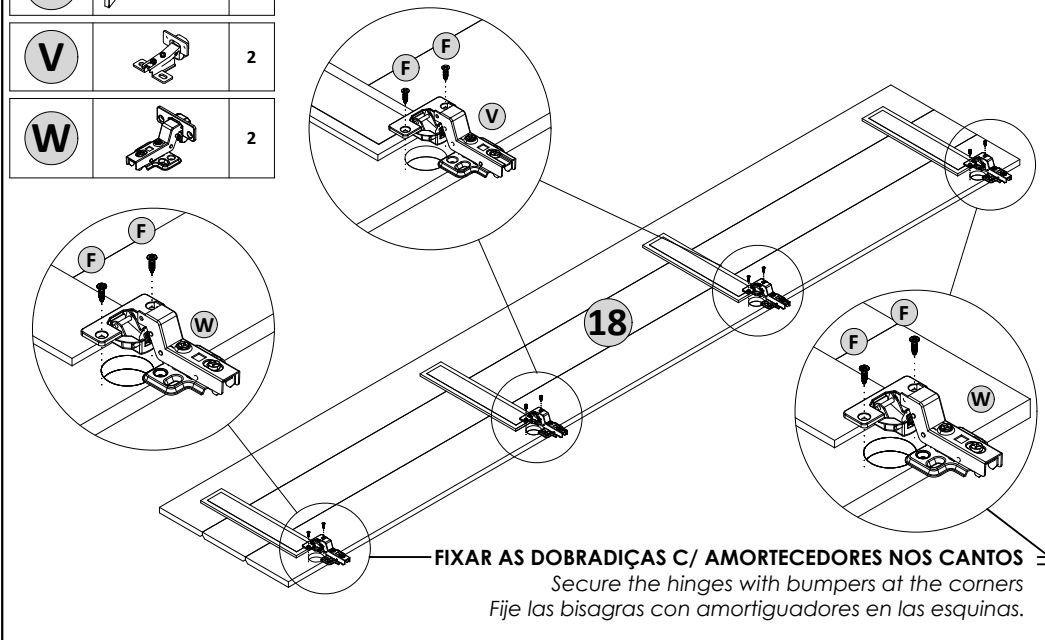

FIXAR AS DOBRADIÇAS C/ AMORTECEDORES NOS CANTOS

Secure the hinges with bumpers at the corners
Fije las bisagras con amortiguadores en las esquinas.

ATENÇÃO!!

Fixar os cabideiros extensíveis antes de colocar as portas









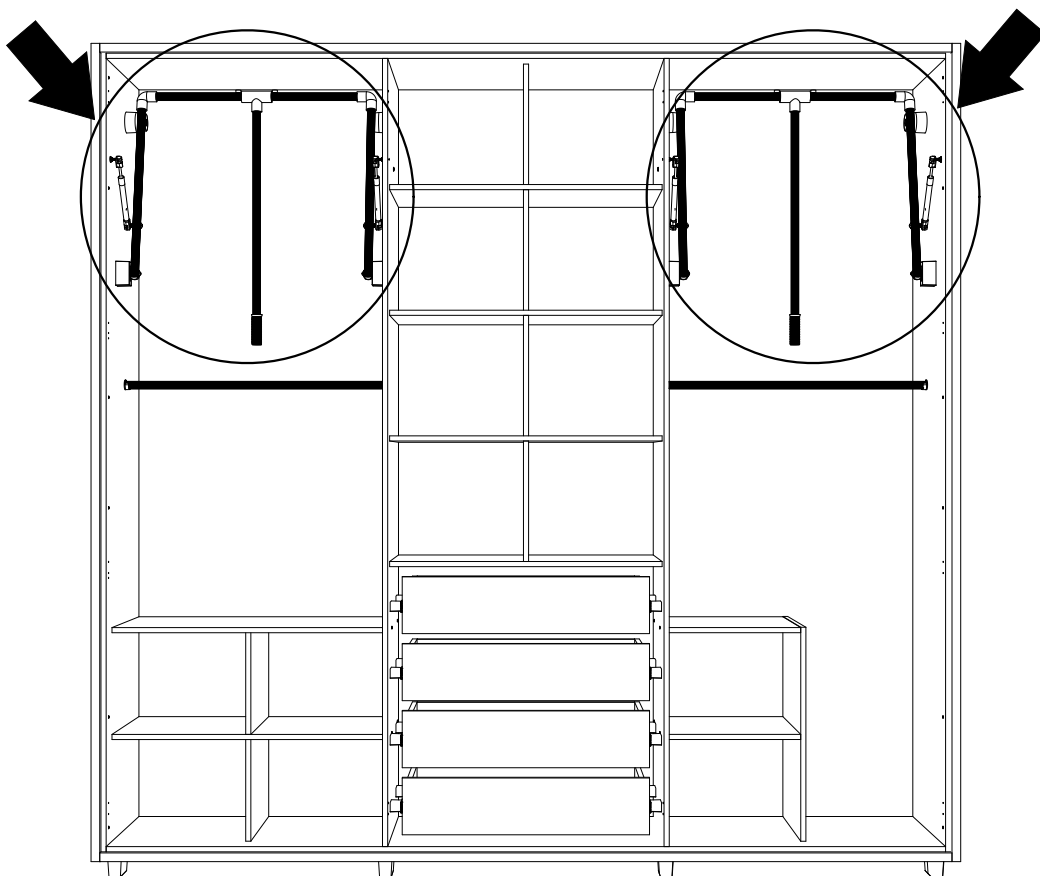

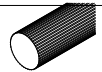

ATTENTION!!

Fix the pull-out hangers before installing the doors

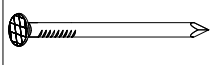
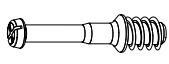
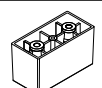
ATENCION!!

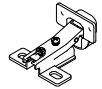
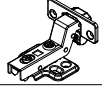
Coloque las perchas extensibles antes de colocar las puertas



LETRA LETTER	DESCRIÇÃO DESCRIPTION DESCRIPCIÓN	MATÉRIA PRIMA FEEDSTOCK	QUANTIDADE AMOUNT CANTIDAD	CÓDIGO CODE
J	 Corrediça telescópica Drawer slide Diapositivas del cajón	Metal	4	102010026
K	 Tubo redondo estriado 791mm Ribbed round tube 791mm Tubo redondo acanalado 7914mm	Metal	2	102050057
L	 Pé de plástico Plastic foot Pie de plastico	Plástico Plastic	8	102110038
M	 Cantoneira aço 17,5x17,5x46mm zincada Angle steel 17.5x17.5x46mm zinc-plated Ángulo de acero 17,5x17,5x46mm cincado	Metal	8	102050041
N	 Cavilha 6x30mm Dowel 6x30mm Clavija 6x30mm	Madeira Wood Madera	62	102050001
O	 Castanha girofix 12x10mm Girofix chestnut 12x10mm Castaña girofix 12x10mm	Metal	17	102050006
P	 Chapa fixador de fundo Bottom fixing plate Placa fijadora de fondo	Metal	60	102050002
Q	 Pregão 10x10 Nail 10x10 Clavo 10x10	Metal	210	102100009
R	 Pino girofix 5,0x30mm Girofix pin 5,0x30mm Pino girofix 5,0x30mm	Metal	17	102050007
S	 Distanciador para corrediça 32mm Spacer for slide 32mm Espaciador para corredera 32mm	Plástico Plastic	16	102060060
T	 Suporte cabideiro redondo Round coat rack Perchero redondo	Plástico Plastic	4	102060153
U	 Cantoneira suporte triangular Triangle support angle Cantonera soporte triangular	Plástico Plastic	12	102050037
V	 Dobradiça Curva 35mm com calço 35mm Curved Hinge with Shim Bisagra Curva 35mm con cuña	Metal	12	102010055
W	 Dobradiça Curva 35mm c/ calço c/ amortecedor 35mm Curved Hinge with Damper Wedge Bisagra curva de 35 mm con almohadilla amortiguadora	Metal	12	102010055
X	 Porca metálica S4 CH7 ZI 8x8x3mm Metal nut S4 CH7 ZI 8x8x3mm Tuerca de metal S4 CH7 ZI 8x8x3mm	Metal	16	102100008
Y	 Puxador VIENNA 32 cm CHAMPAGNE VIENNA Handle 32 cm CHAMPAGNE Tirador VIENNA 32 cm CHAMPAGNE	Metal	4	102020054
Z	 Etiqueta resinada Resin label Etiqueta en resina	Plástico Plastic	1	102080013
a	 Saco de cola 12g Sachet of glue 0,42oz Bolsita de pegamento 0,42oz	Cola Glue	2	102050020

1º PASSO | PASS | PASO

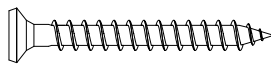
PEÇAS PIECES PIEZAS	D		20
---------------------------	----------	--	----

S.M.	C.P.
01	01
02	23
03	23
04	24
05	24
06	24
07	24
08	25

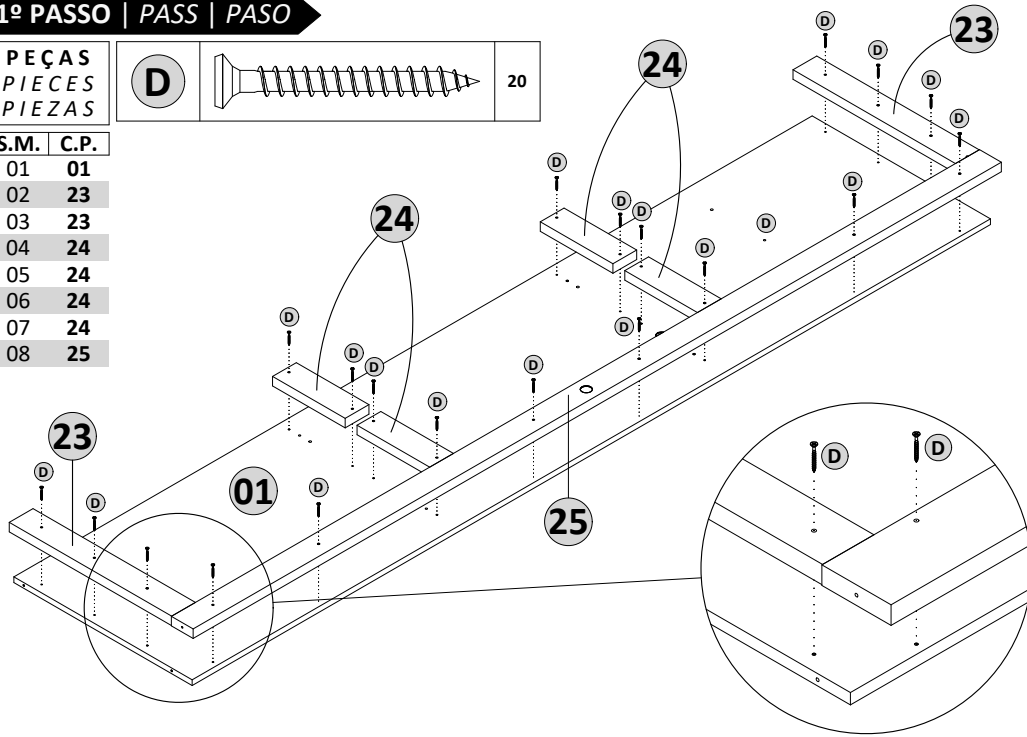

2º PASSO | PASS | PASO

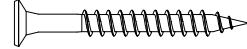
B		16
----------	---	----

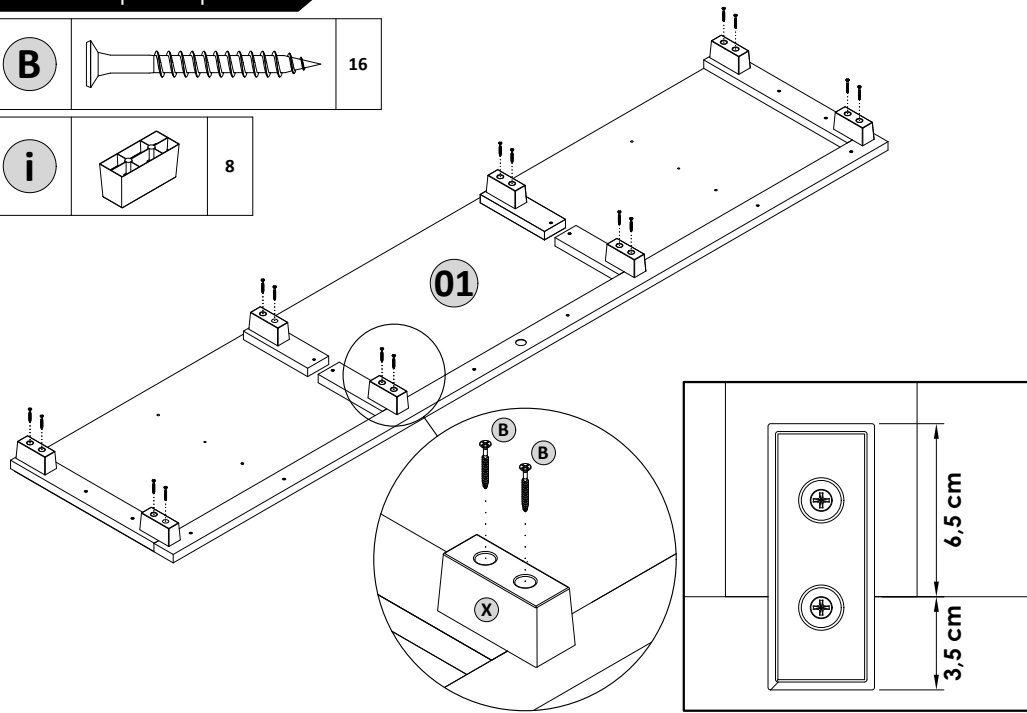

i		8
----------	--	---

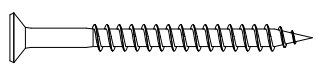
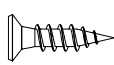

15º PASSO | PASS | PASO

PEÇAS PIECES PIEZAS	C		24	G		88
---------------------------	----------	--	----	----------	--	----

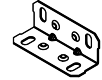
S.M.	C.P.
01	19
02	12
03	12
04	20
05	28
06	02

N		24	M		8	J		8
----------	---	----	----------	---	---	----------	---	---

MONTAGEM DAS GAVETAS | DRAWER ASSEMBLY | MONTAJE DEL CAJÓN

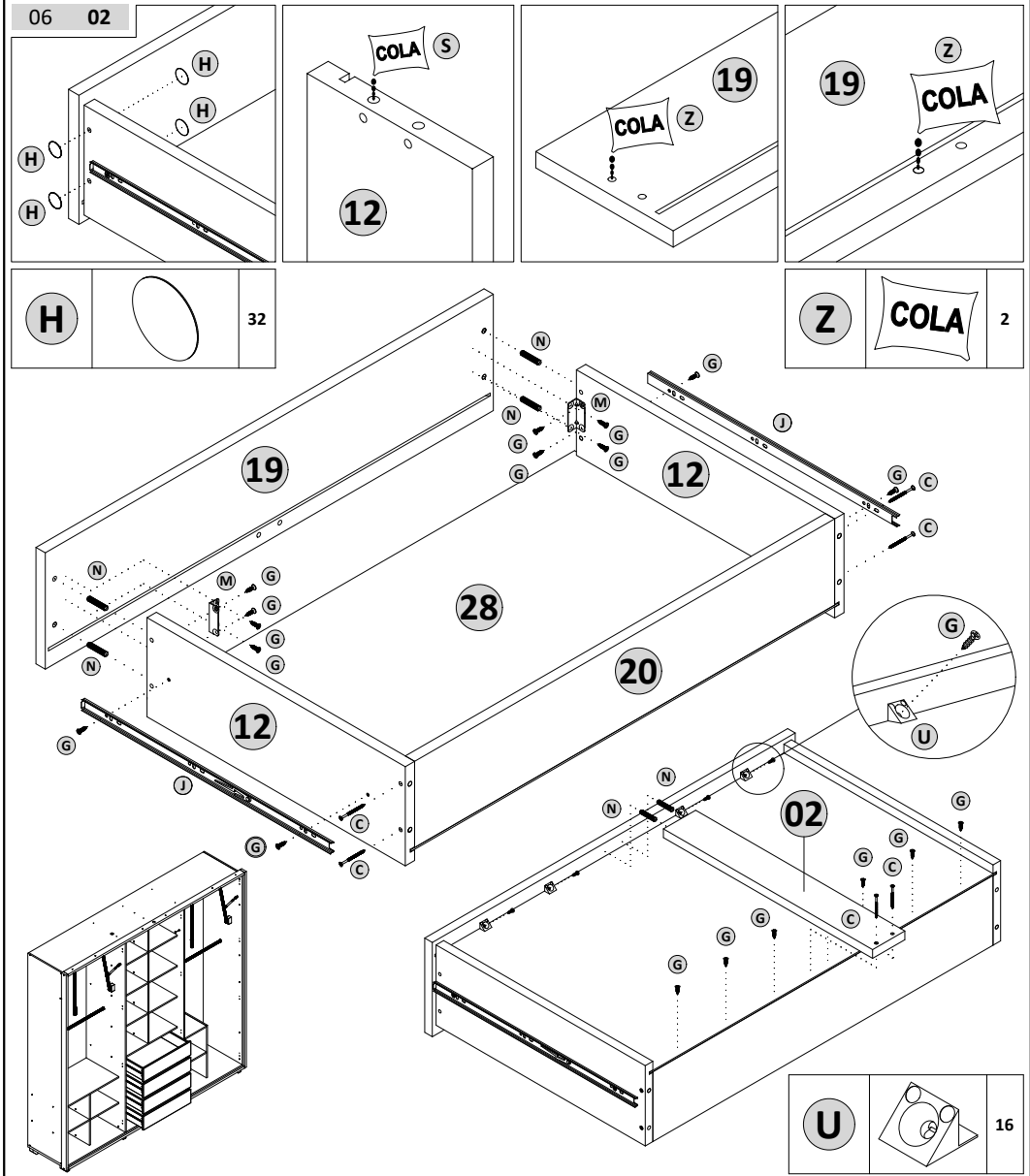

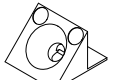
U		16
----------	---	----

14º PASSO | PASS | PASO

PEÇAS	Q		210
PIECES			
PIEZAS			

S.M.	C.P.
-------------	-------------

01	31
02	22
03	31
04	32
05	32
06	29
07	29
08	30
09	22
10	30
11	22
12	30
13	29
14	33
15	21
16	30
17	22
18	30
19	22
20	30

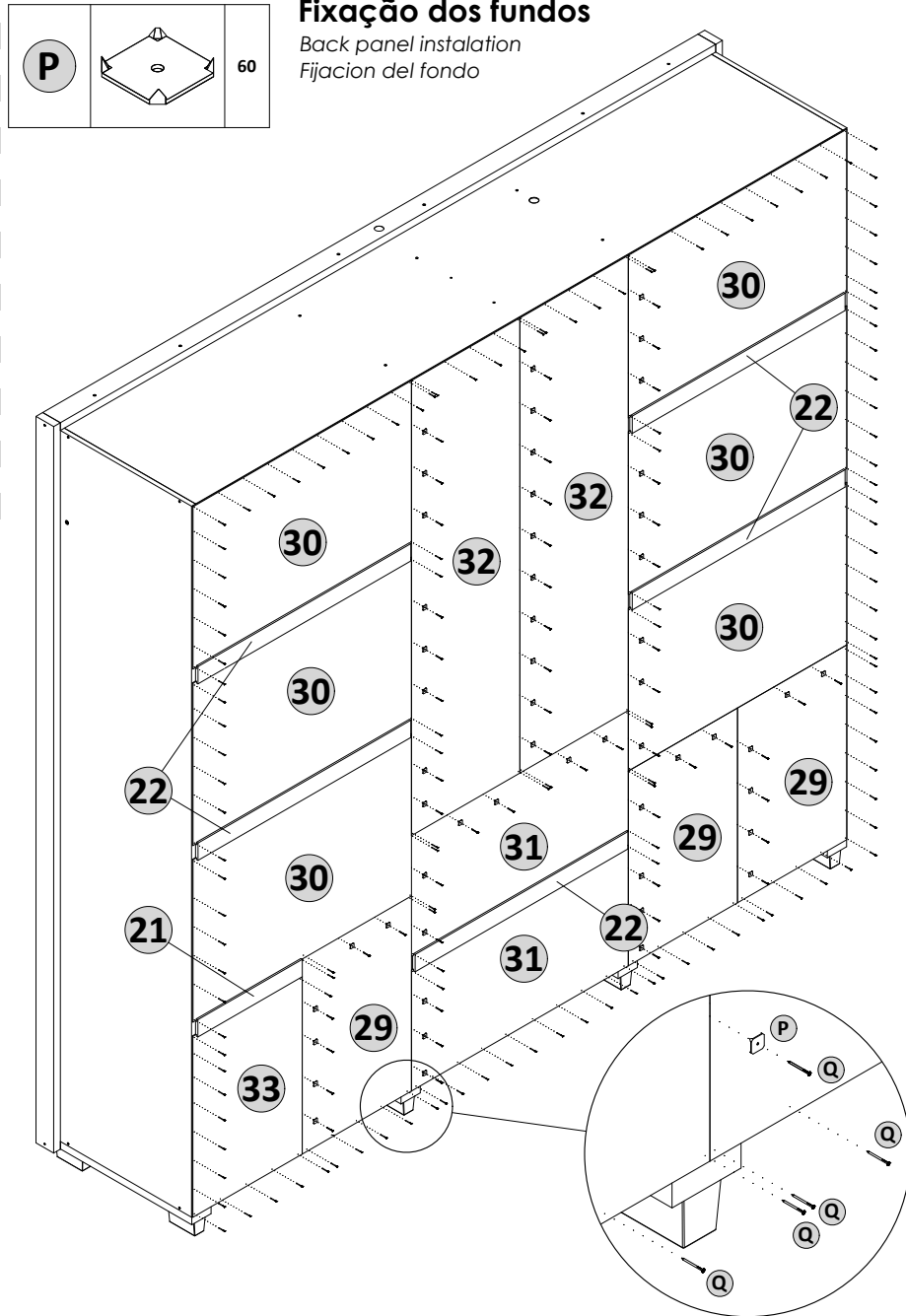

ATENÇÃO!! | ATTENTION!! | ATENCION!!

Coloque os cabideiros antes de fixar os fundos
 Place the hangers before attaching the bottoms
 Coloque las perchas antes de colocar los fondos

Fixação dos fundos



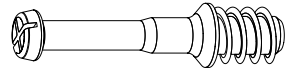

Back panel installation
 Fijación del fondo

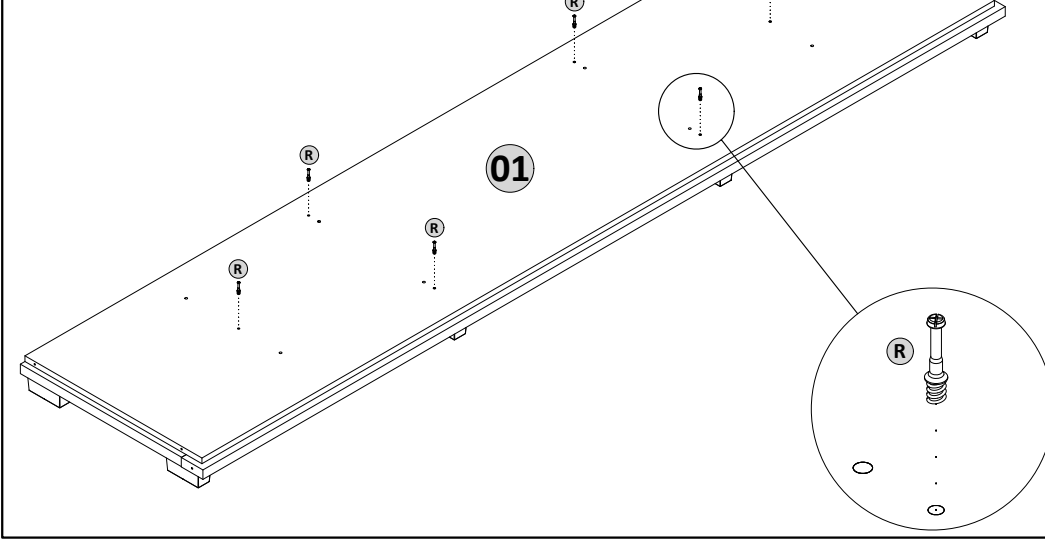
3º PASSO | PASS | PASO

R		6
----------	--	---

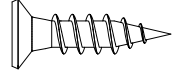

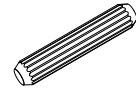
4º PASSO | PASS | PASO

G		24	J		4
N		4			
S		8			

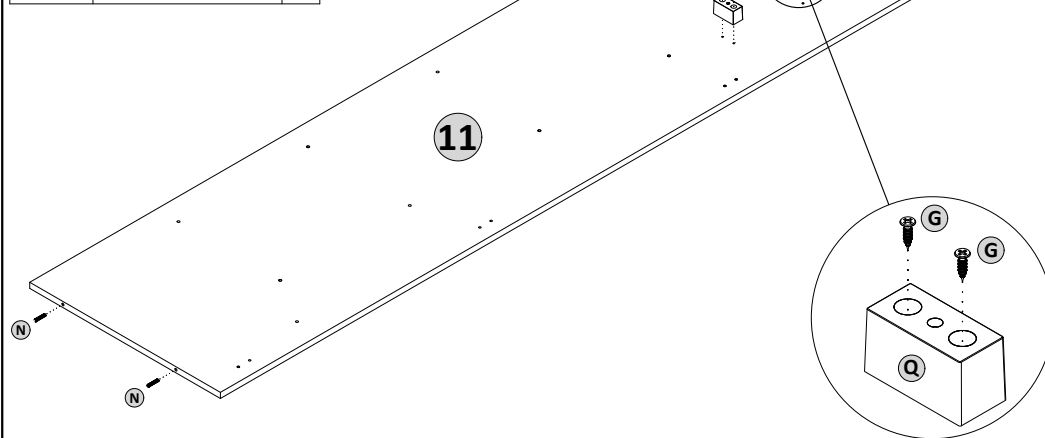

5º PASSO | PASS | PASO

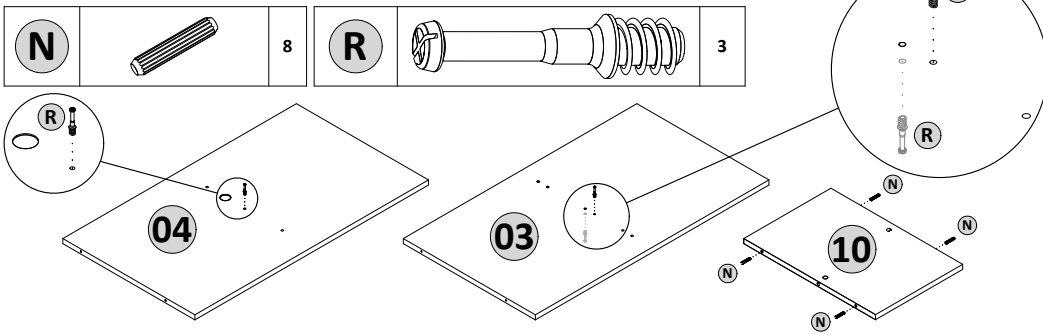

6º PASSO | PASS | PASO

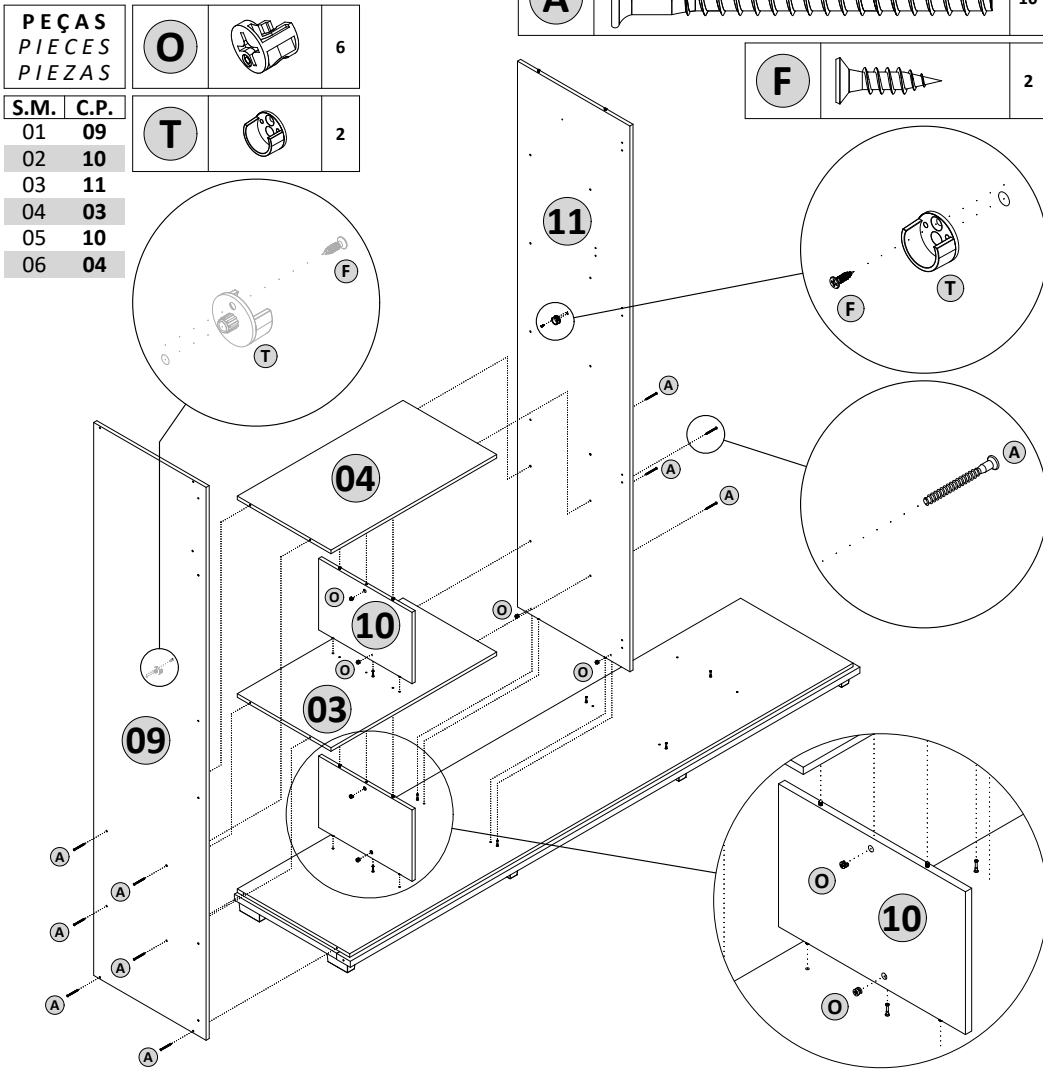

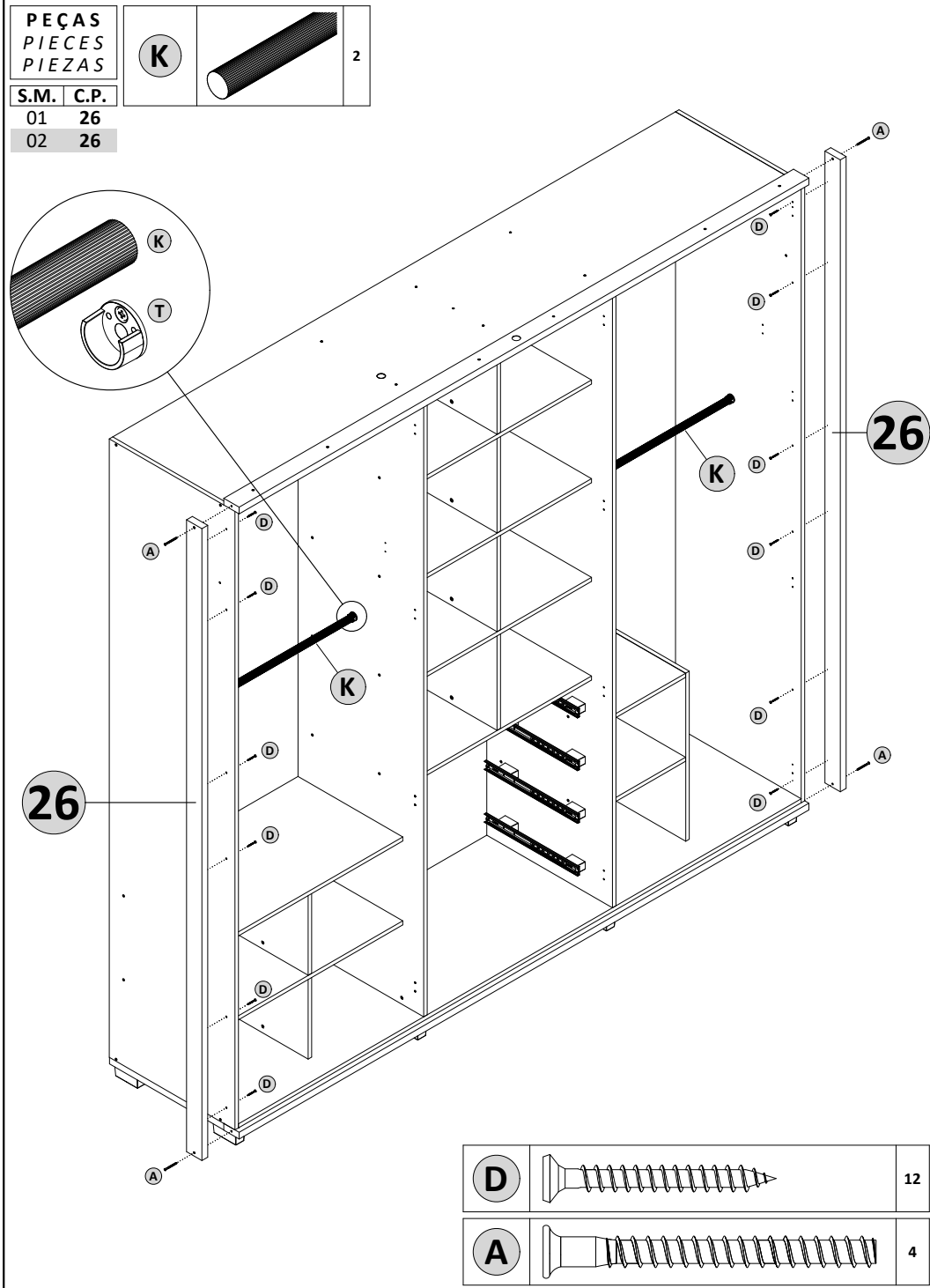

13º PASSO | PASS | PASO



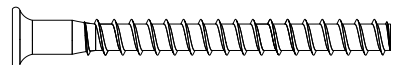
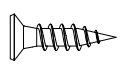

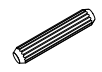
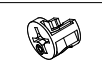
12º PASSO | PASS | PASO

PEÇAS PIECES PIEZAS		A		14	F		2
---------------------------	--	----------	--	----	----------	--	---

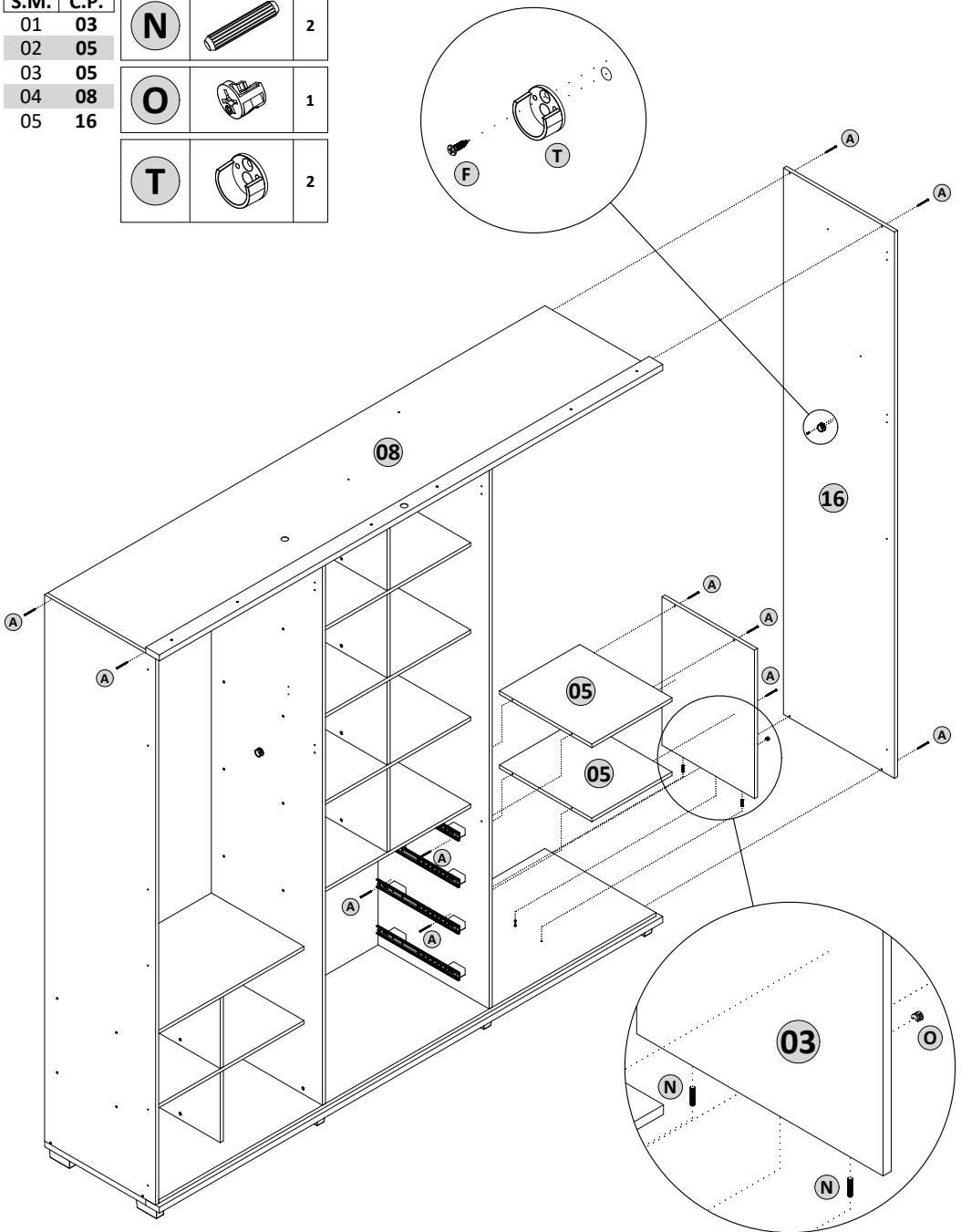
S.M.	C.P.	N		2
01	03	O		1
02	05	T		2

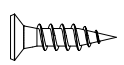

7º PASSO | PASS | PASO

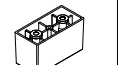
F		24	J		4	N		4	S		8
----------	--	----	----------	--	---	----------	--	---	----------	--	---

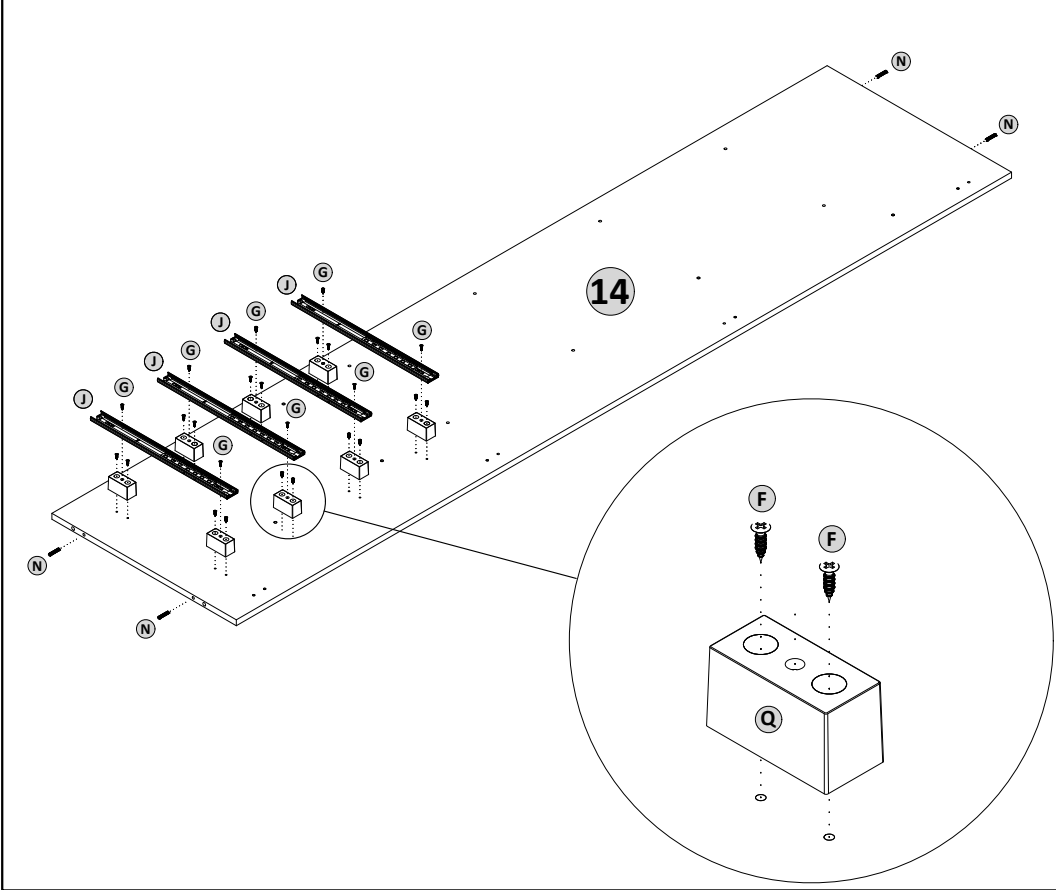

8º PASSO | PASS | PASO

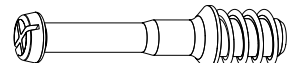
N		16	R		7
----------	---	----	----------	---	---

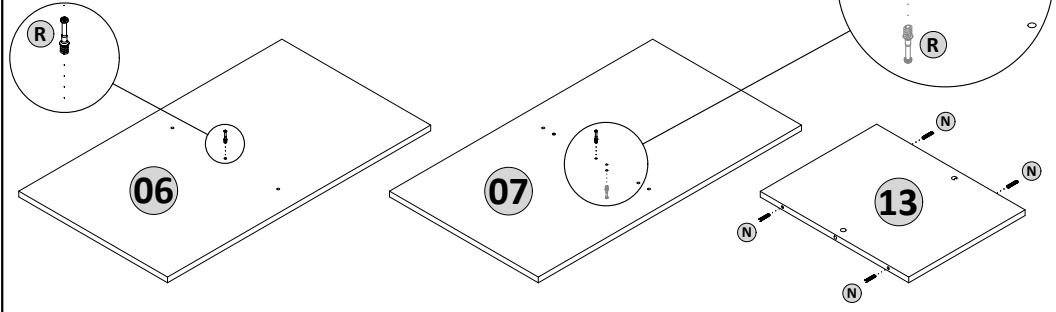

9º PASSO | PASS | PASO

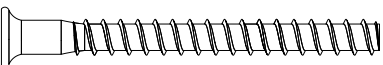
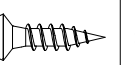
PEÇAS PIECES PIEZAS	A		16	F		1
--	----------	--	----	----------	--	---

S.M.	C.P.
01	14
02	06
03	13
04	07
05	13
06	07
07	13
08	07
09	13

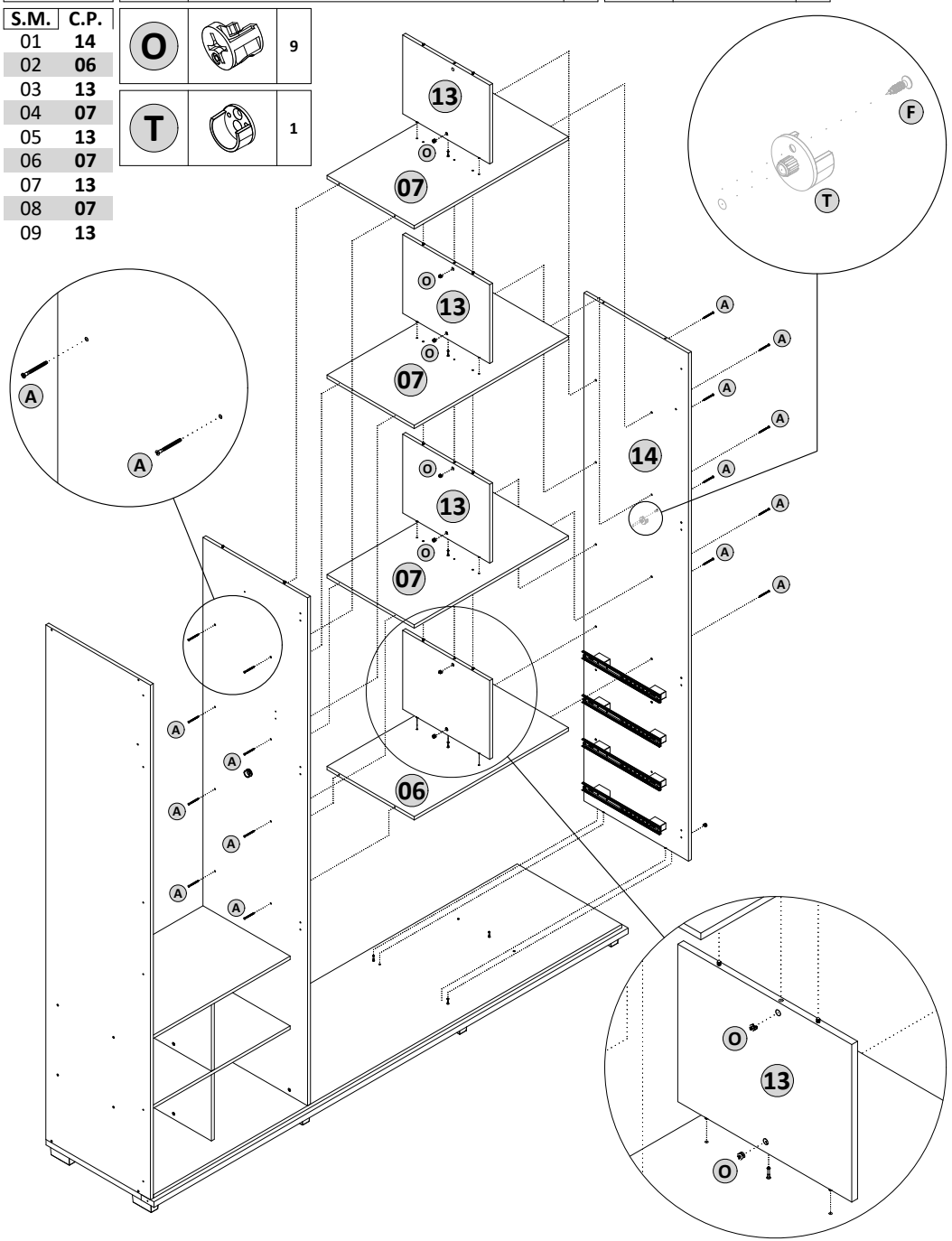

10º PASSO | PASS | PASO

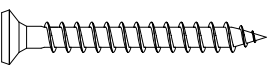
PEÇAS PIECES PIEZAS	D		6
--	----------	--	---

S.M.	C.P.
01	08
02	25

FIXAÇÃO DA MOLDURA NO CHAPÉU
FIXING THE FRAME TO THE UPPER PANEL
FIJACIÓN DEL MARCO AL PANEL SUPERIOR

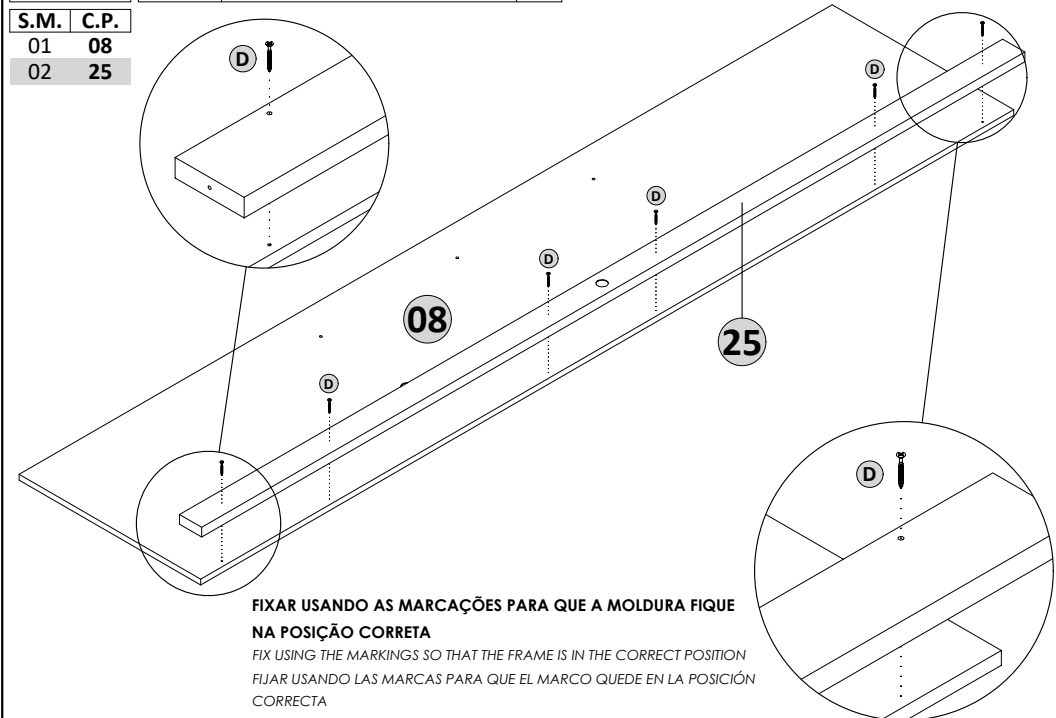

FIXAR USANDO AS MARCAÇÕES PARA QUE A MOLDURA FIGUE NA POSIÇÃO CORRETA
FIX USING THE MARKINGS SO THAT THE FRAME IS IN THE CORRECT POSITION
FIJAR USANDO LAS MARCAS PARA QUE EL MARCO QUEDE EN LA POSIÇÃO CORRECTA

11º PASSO | PASS | PASO

O		1
----------	--	---

