

## YOU WILL NEED

TU AURAS BESOIN DE | NECESITARÁ | VOCÊ VAI PRECISAR

			<p><b>Hammer.</b> Marteau. Martillo. Martelo.</p>
	<p><b>Drill machine.</b> Perceuse. Taladro. Furadeira.</p>		<p><b>5/16" 8mm</b> <b>Drill bit.</b> Foret. Broca. Broca.</p>
<p><b>Measuring tape.</b> Mètre ruban. Cinta métrica. Fita métrica.</p>	<p><b>Pencil.</b> Crayon. Lápiz. Lápis.</p>		<p><b>2 Person.</b> 2 Personnes. 2 Personas. 2 Pessoas.</p>

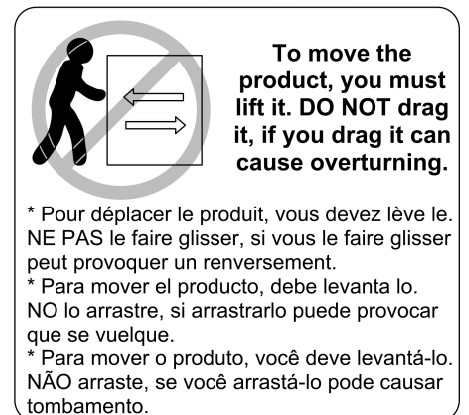
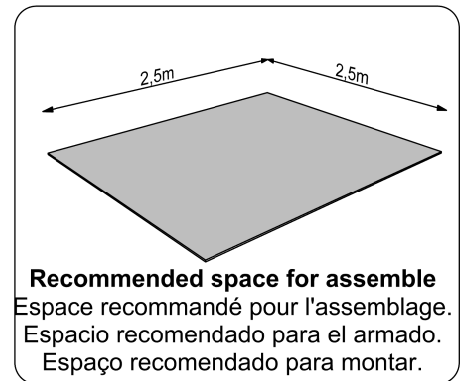

## Tools not included

Outils non inclus | Herramientas no incluidas | Ferramentas não inclusas

# ACCESSORIES IDENTIFICATION

IDENTIFICATION DES ACCESSOIRES | IDENTIFICACIÓN DE ACCESORIOS  
IDENTIFICAÇÃO DOS ACESSÓRIOS

**A**  30mm Qty./Qtd. **32**  
Wooden dowel / Chevilles en bois / Taquete / Cavilha

**AY**  Qty./Qtd. **1**  
Wire finishing / Passer le fil / Cubierta de cableado / Passa Fios

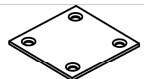
**BA**  Qty./Qtd. **4**  
Sheet metal / Tôle / Lámina de metal / Chapa de metal

**C**  45mm Qty./Qtd. **20**  
Structural screw / Vis à tête structurelle / Tornillo estructural / Parafuso Estrutural

**CT**  Qty./Qtd. **4**  
Metallic bracket / Support métallique / Suporte de metal

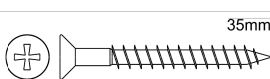
**CU**  35mm Qty./Qtd. **9**  
Structural screw / Vis à tête structurelle / Tornillo estructural / Parafuso Estrutural

**E**  Qty./Qtd. **4**  
Metallic bracket / Support métallique / Suporte de metal

**G**  Qty./Qtd. **28**  
Simple minifix screw / Vis minifix simple / Tornillo minifix simple / Haste Minifix Simples

**H**  Qty./Qtd. **28**  
Drum lock / Verrouillage du tambour / Tambor minifix / Tambor de Minifix

**J**  10 x 10 Qty./Qtd. **33**  
Nail / Ongle / Clavo / Prego

**M**  Qty./Qtd. **8**  
Metalic angle plates / Support métallique / Suporte de metal / Cantoneira de Metal

**N**  14mm Qty./Qtd. **111**  
Pan head screw / Vis à tête bombée / Tornillo de pan / Parafuso Panela

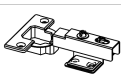
**Q**  35mm Qty./Qtd. **6**  
Metal hinge straight / Charnière métallique droite / Bisagra recta / Dobradiça Reta

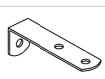
**R**  Qty./Qtd. **4**  
Metalic bracket / Support métallique / Soporte de metal / Suporte de Metal

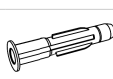
**S**  Qty./Qtd. **4**  
Bushing / Douille expansive / Tapón / Bucha Plástica

**T**  60mm Qty./Qtd. **4**  
Flanged head screw / Vis à tête bride / Tornillo de cabeza flangeada / Parafuso flangeado

**Z**  Qty./Qtd. **4**  
Metal claw / Pince de métal / Garra metal / Garra de Metal

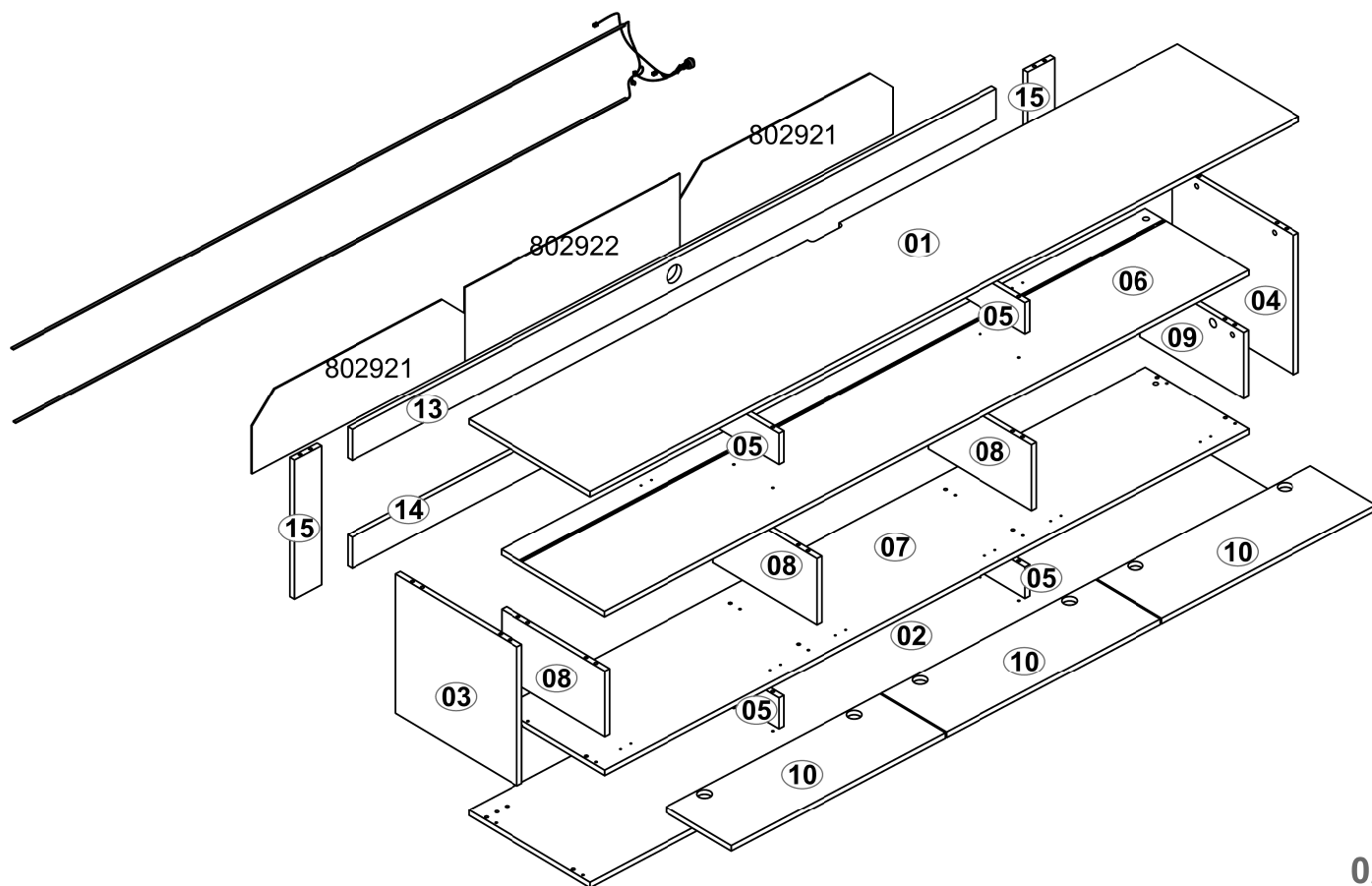

# PRE-ASSEMBLY - PRÉ-ASSEMBLAGE - PRE-ARMADO PRÉ-MONTAGEM

01 -

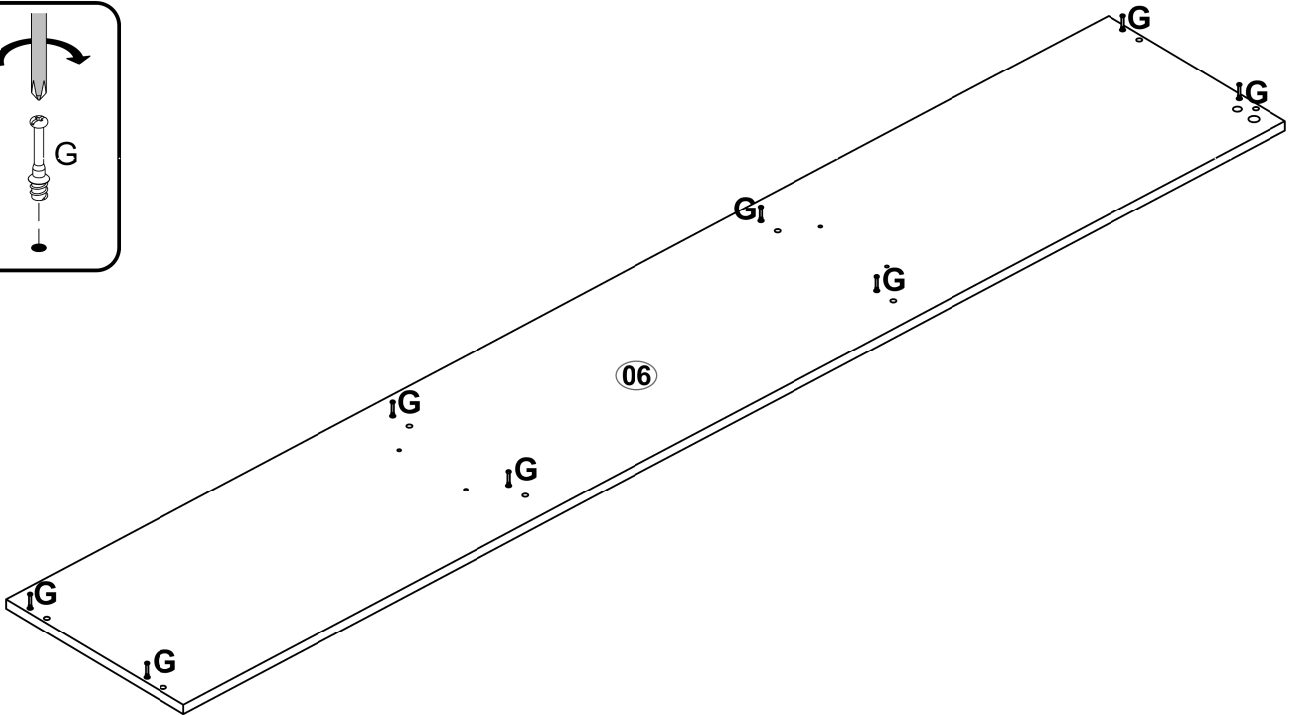
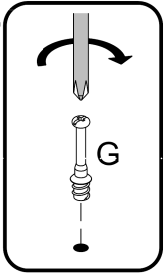

02 -

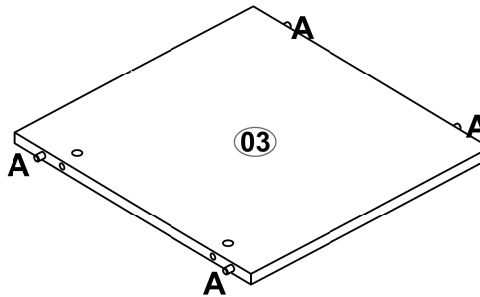
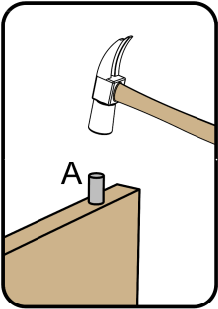

03 -

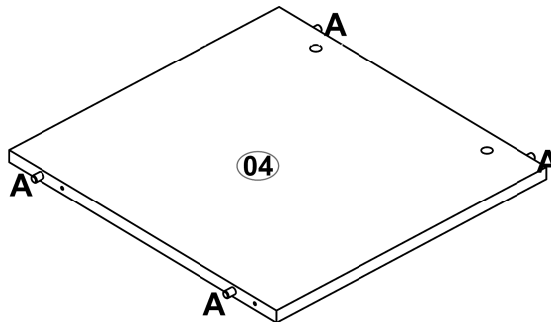
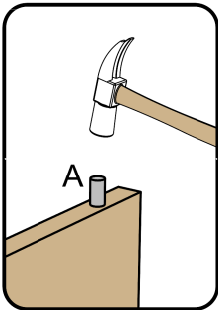

04 -

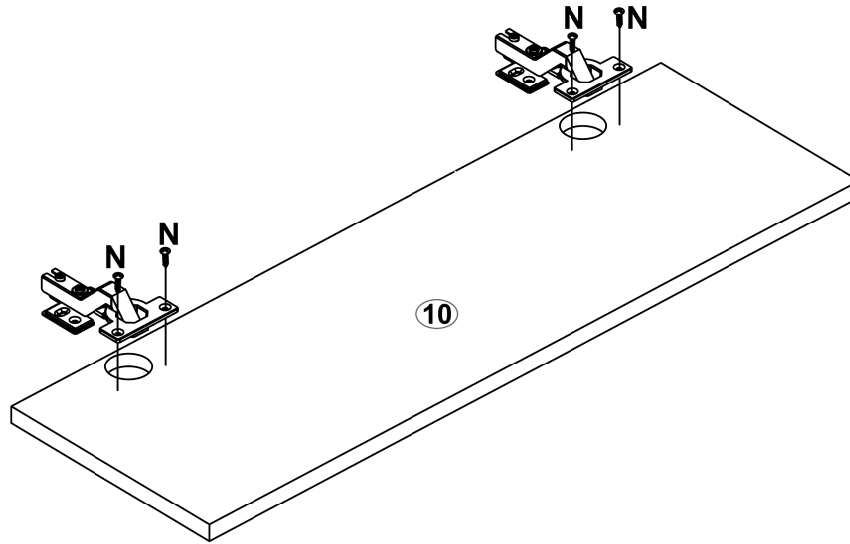

05 -

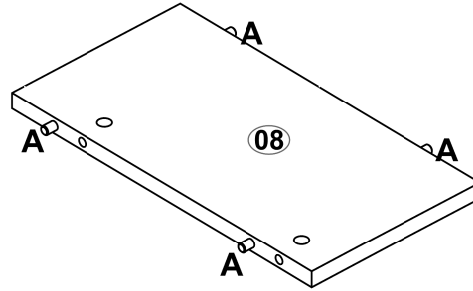
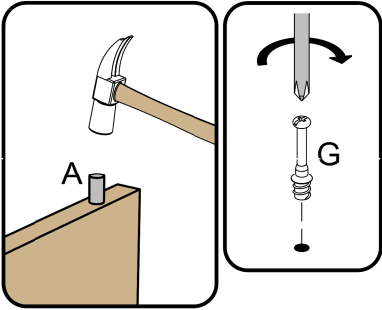

06 -

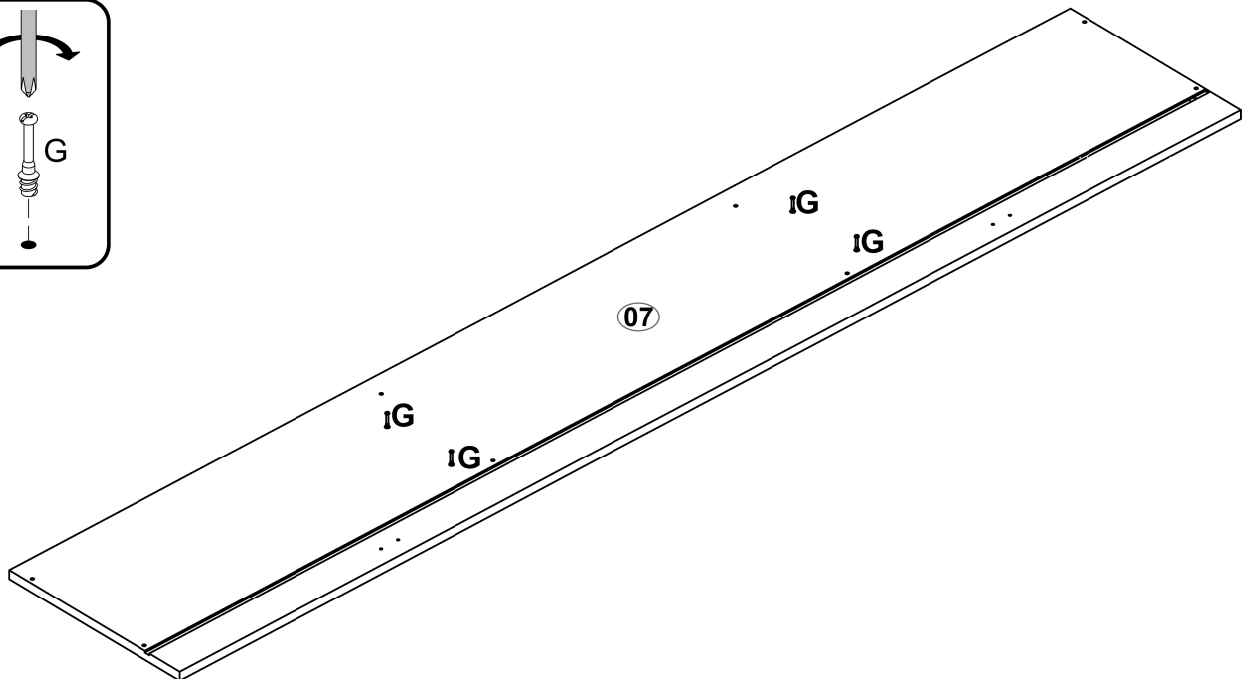
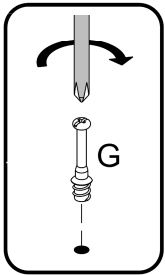

07 -

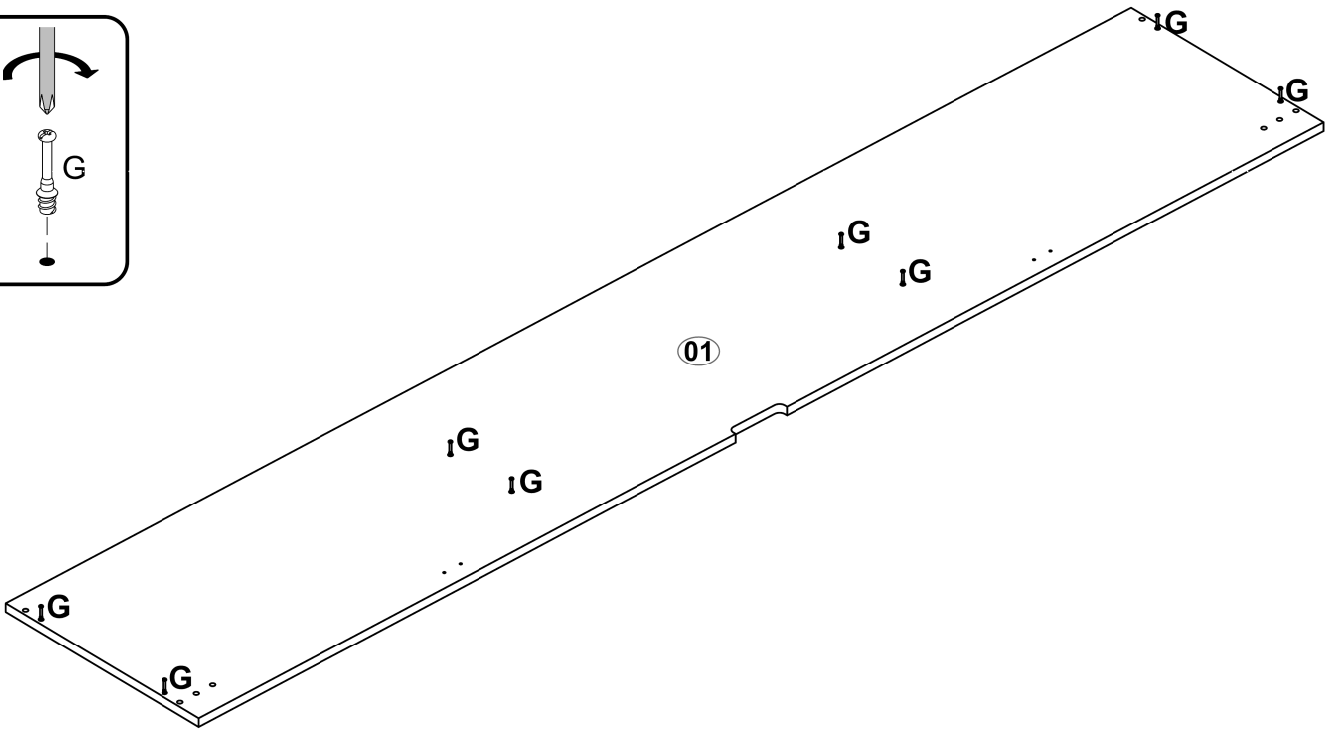
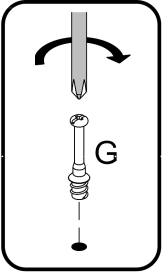

08 -

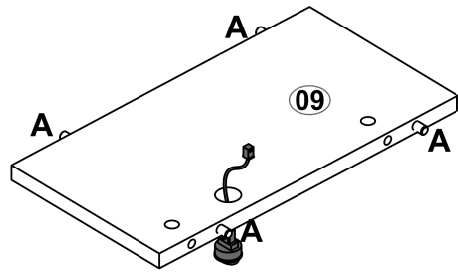
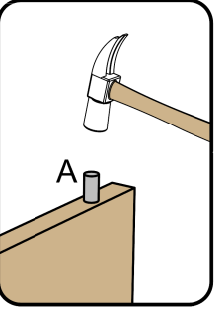

09 -

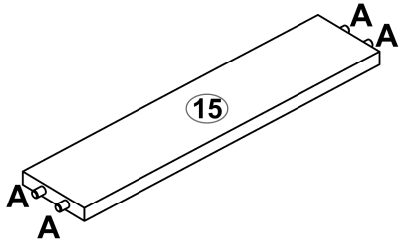
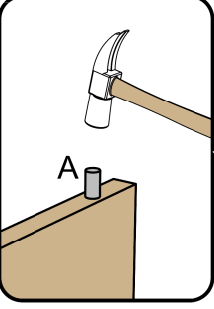

# ASSEMBLY - MONTAGE - ARMADO - MONTAGEM

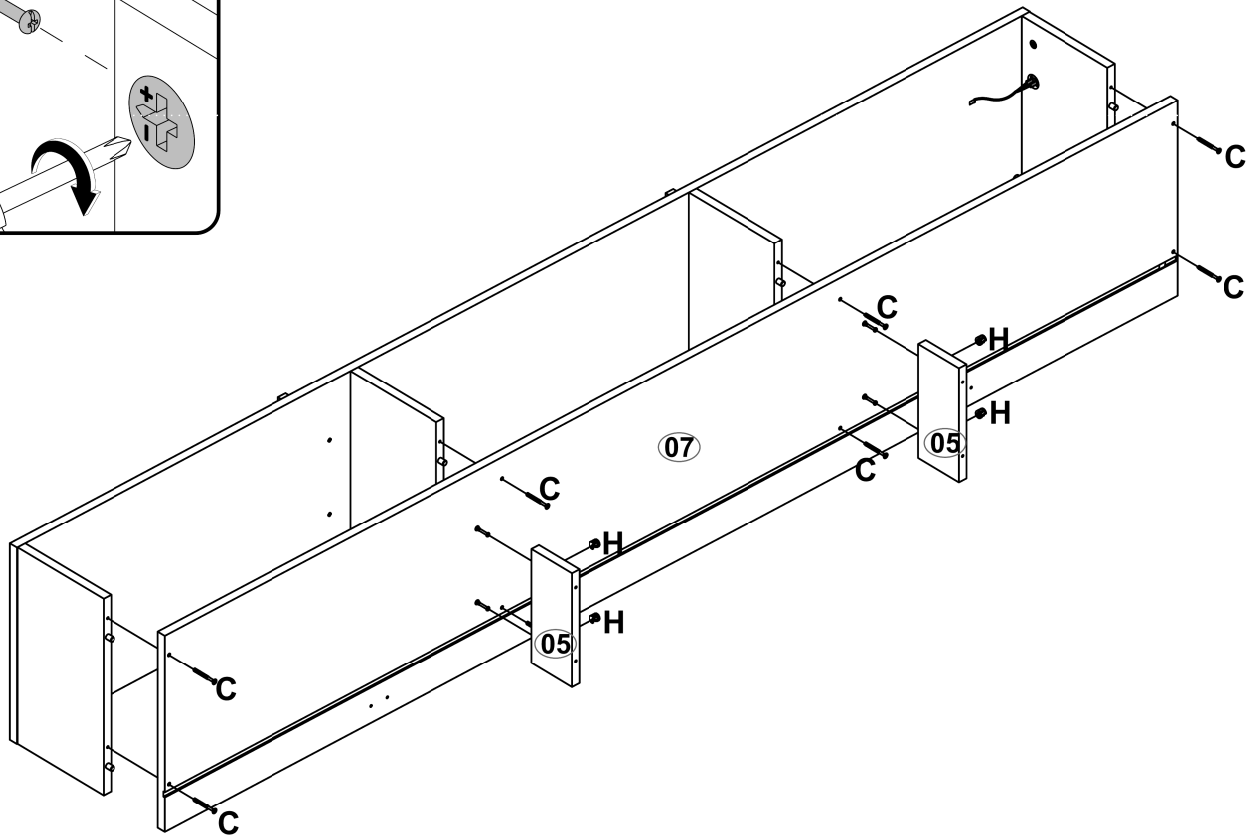
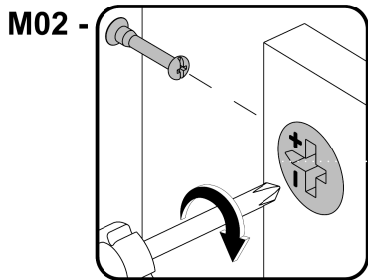
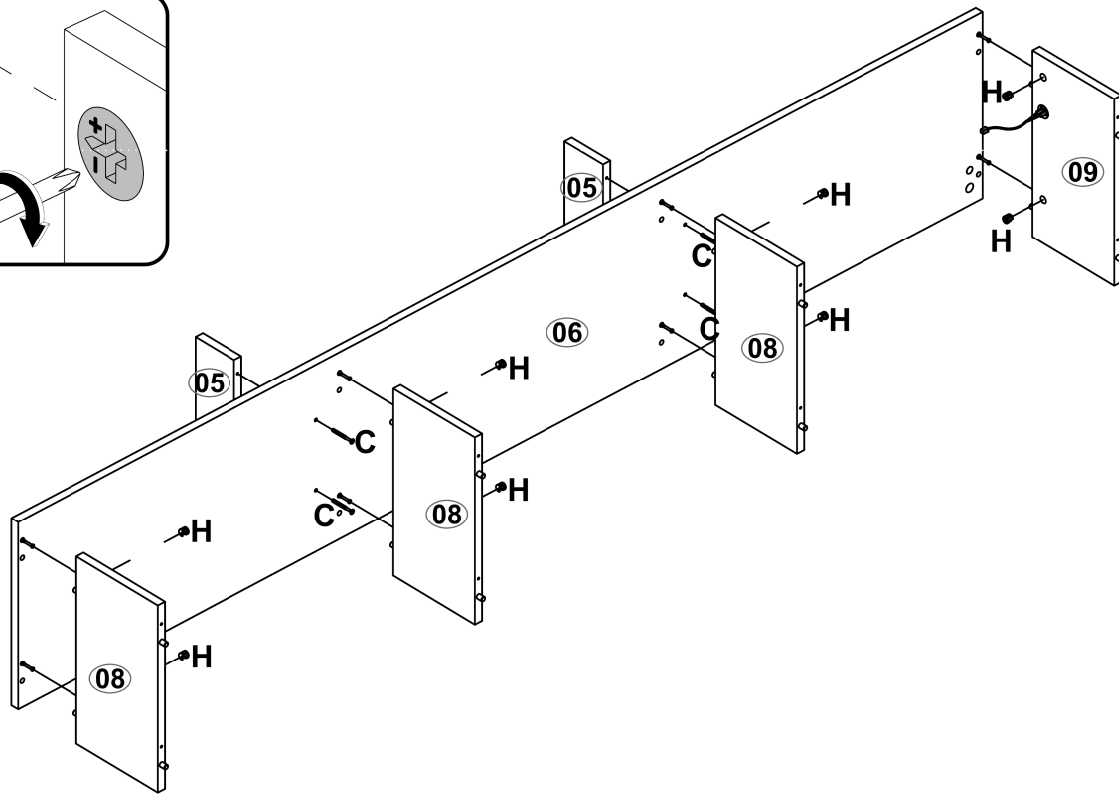
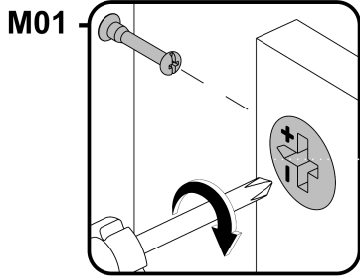

M03 -

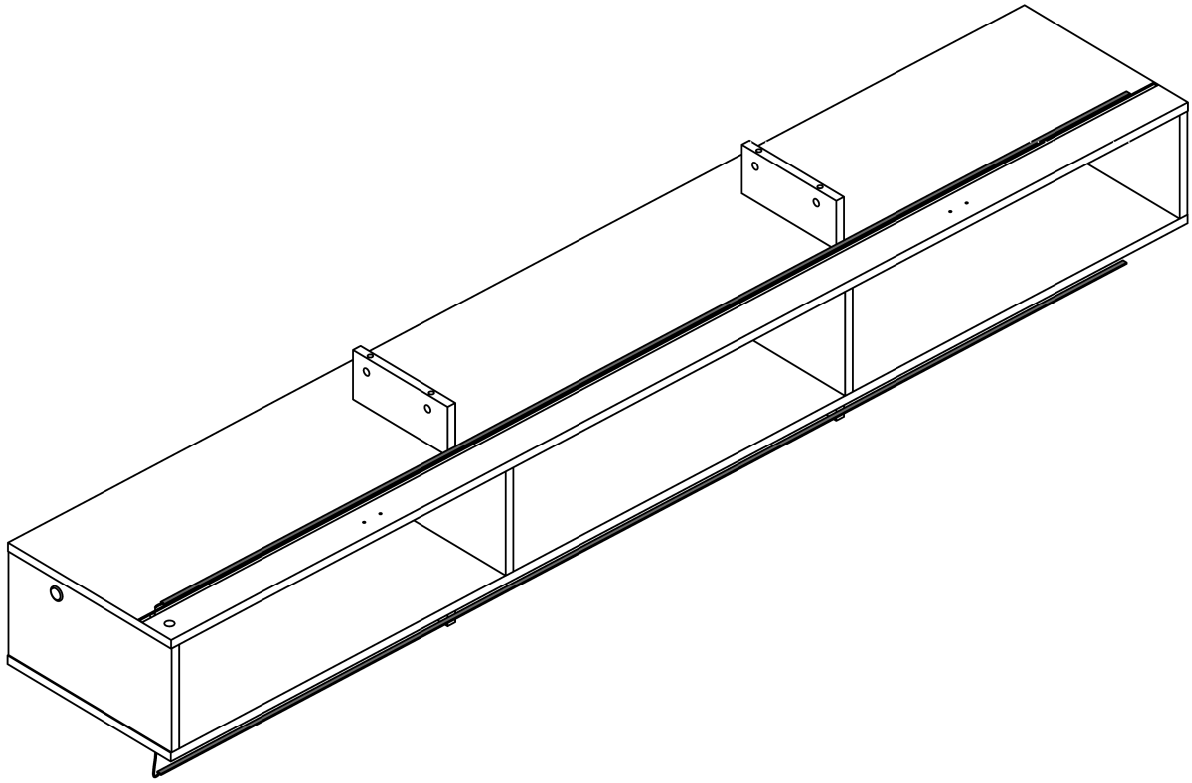

M04 -

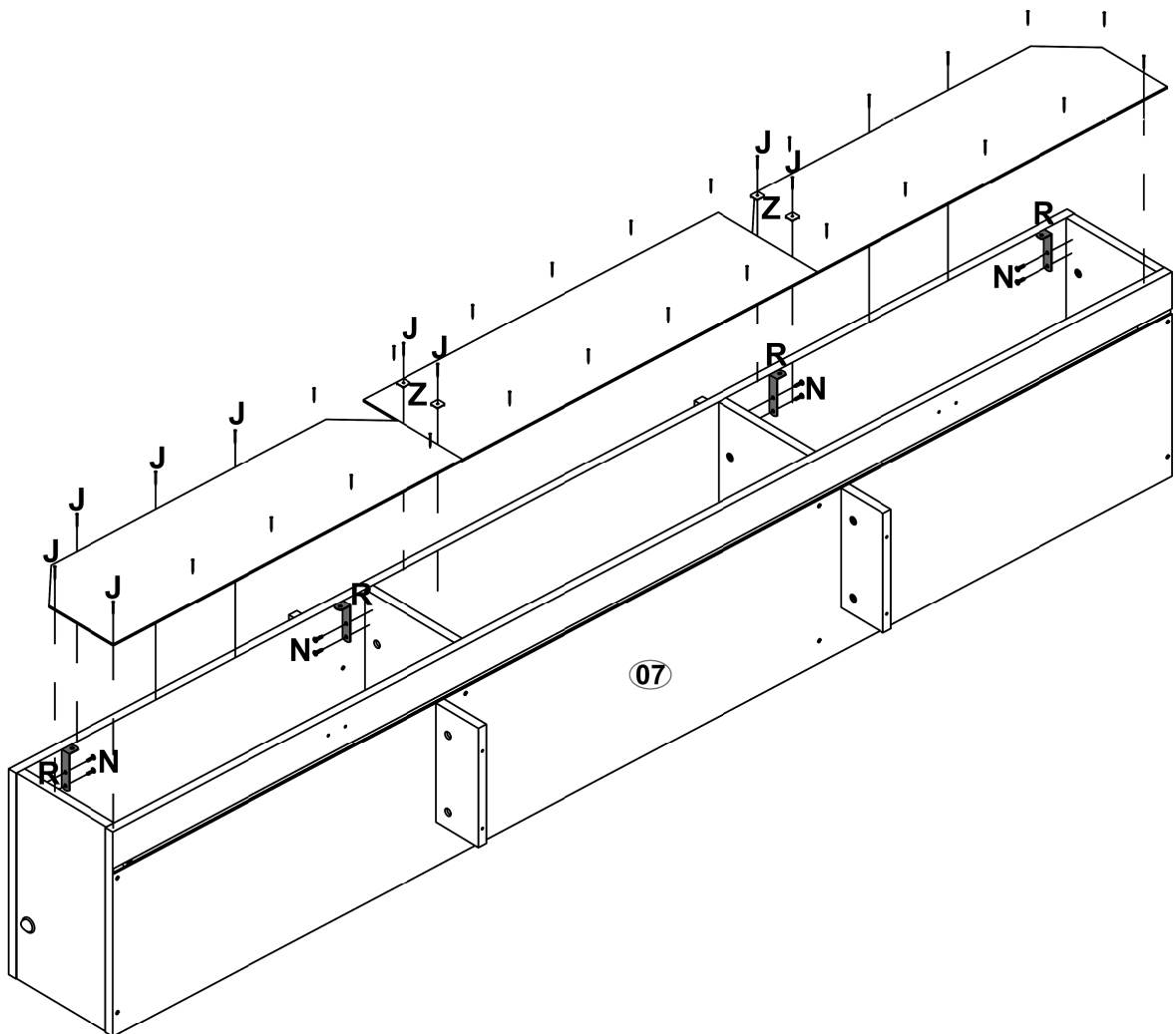

M05 -

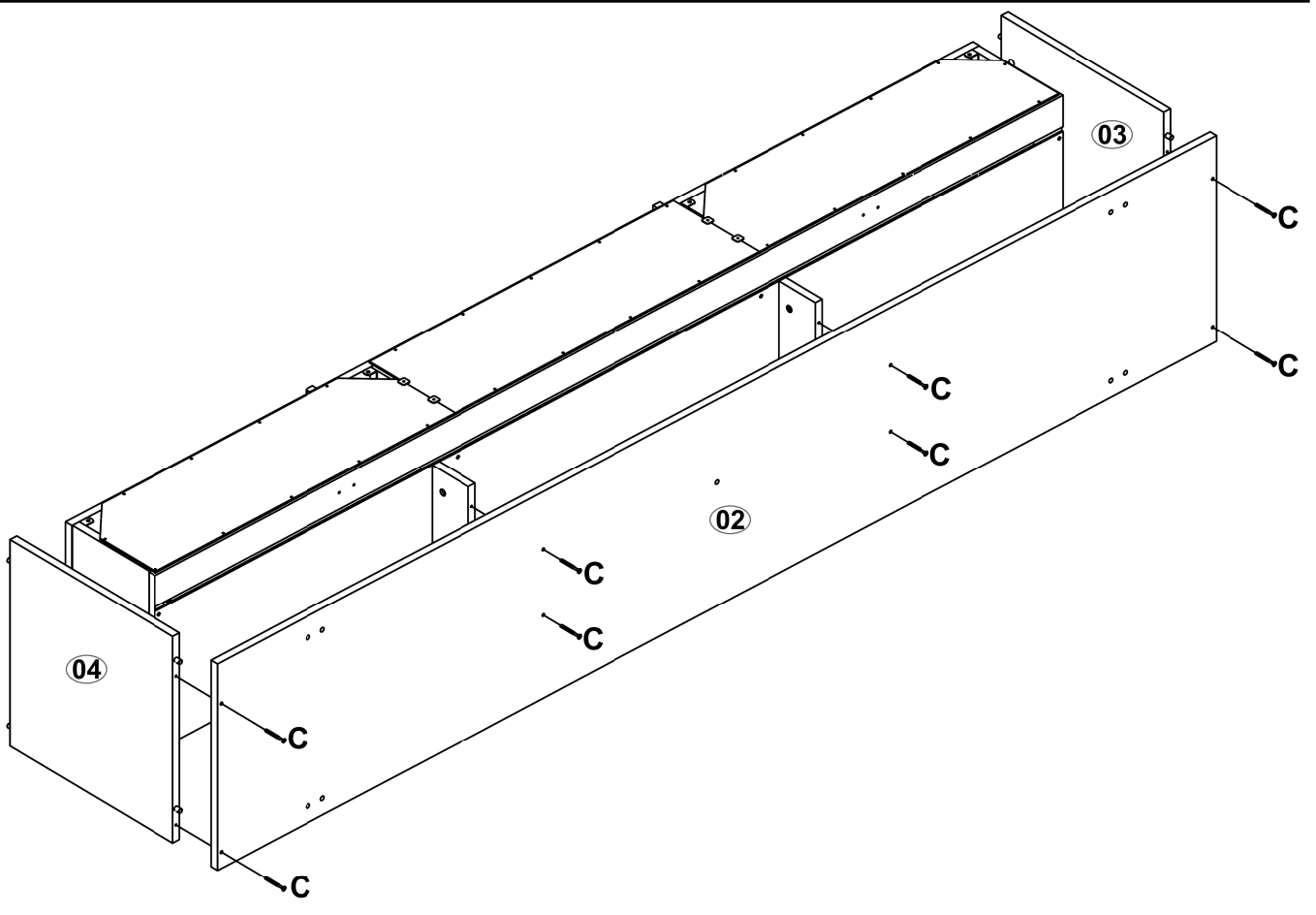

M06 -

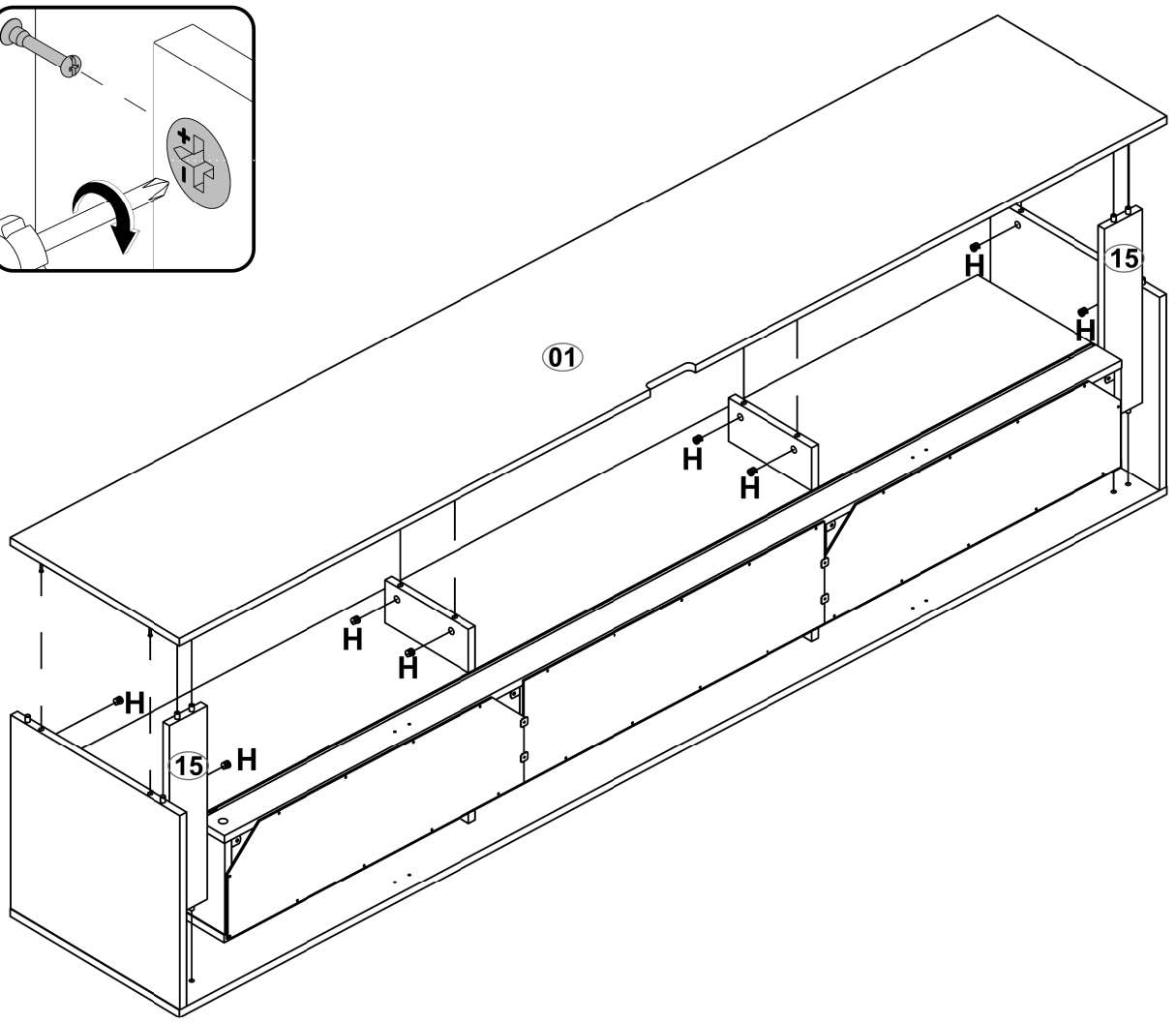
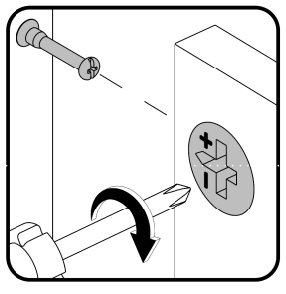

M07 -

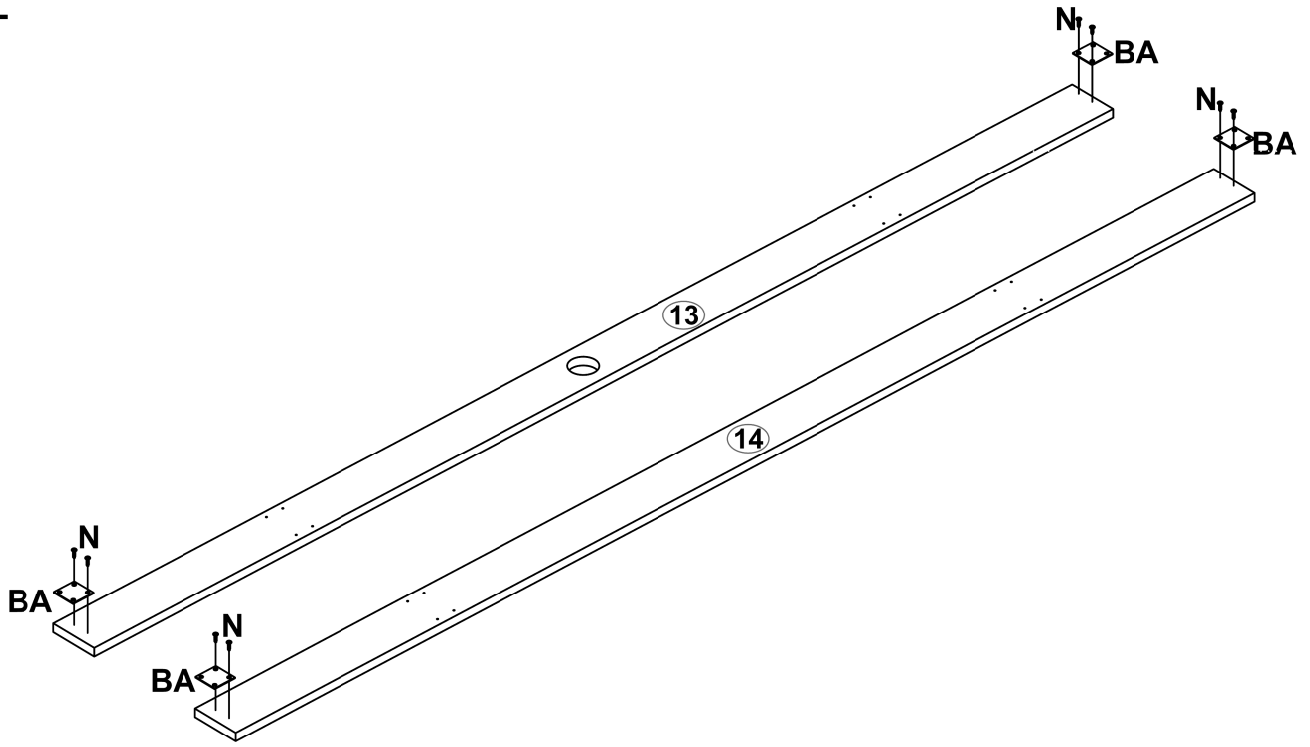

M08 -

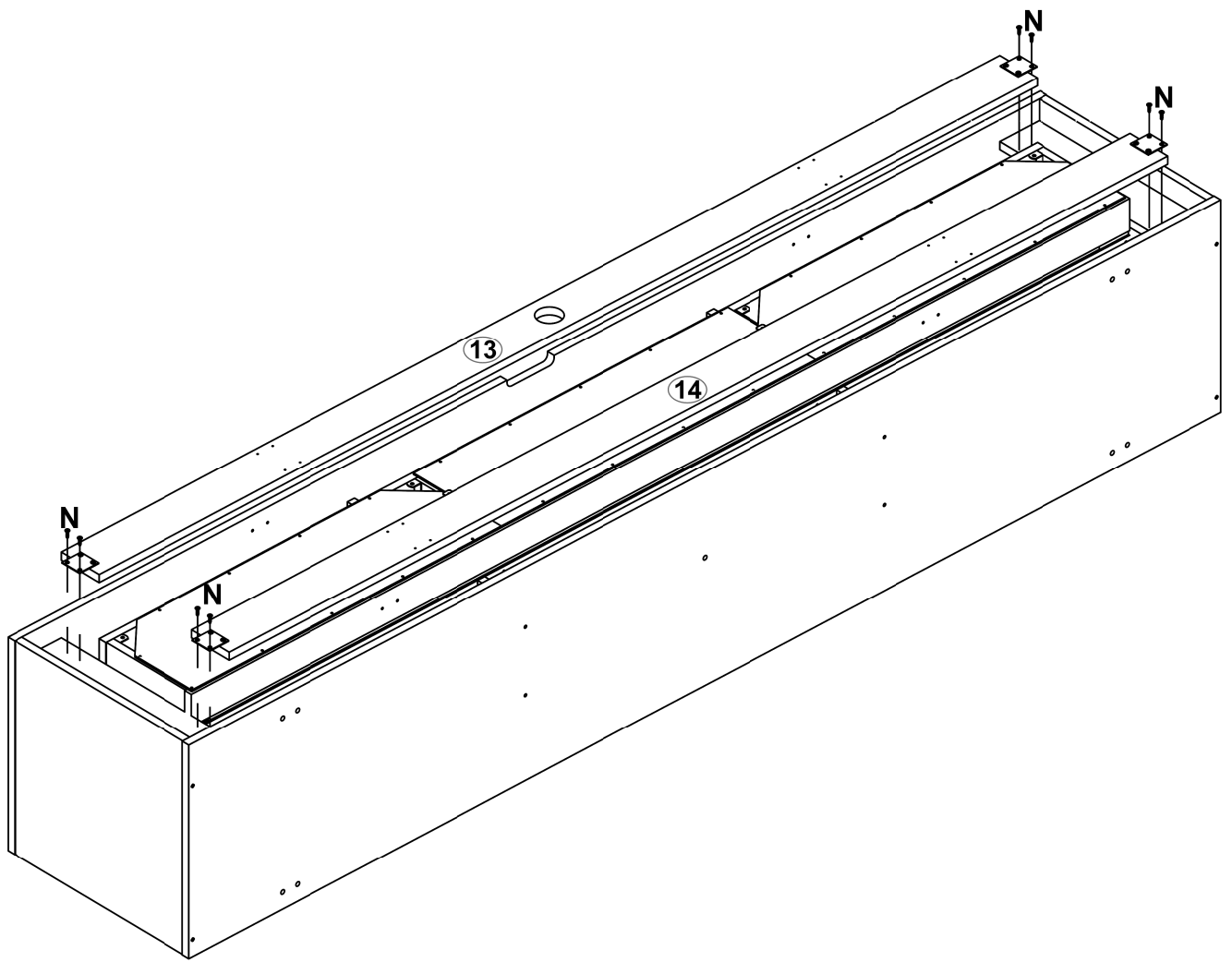

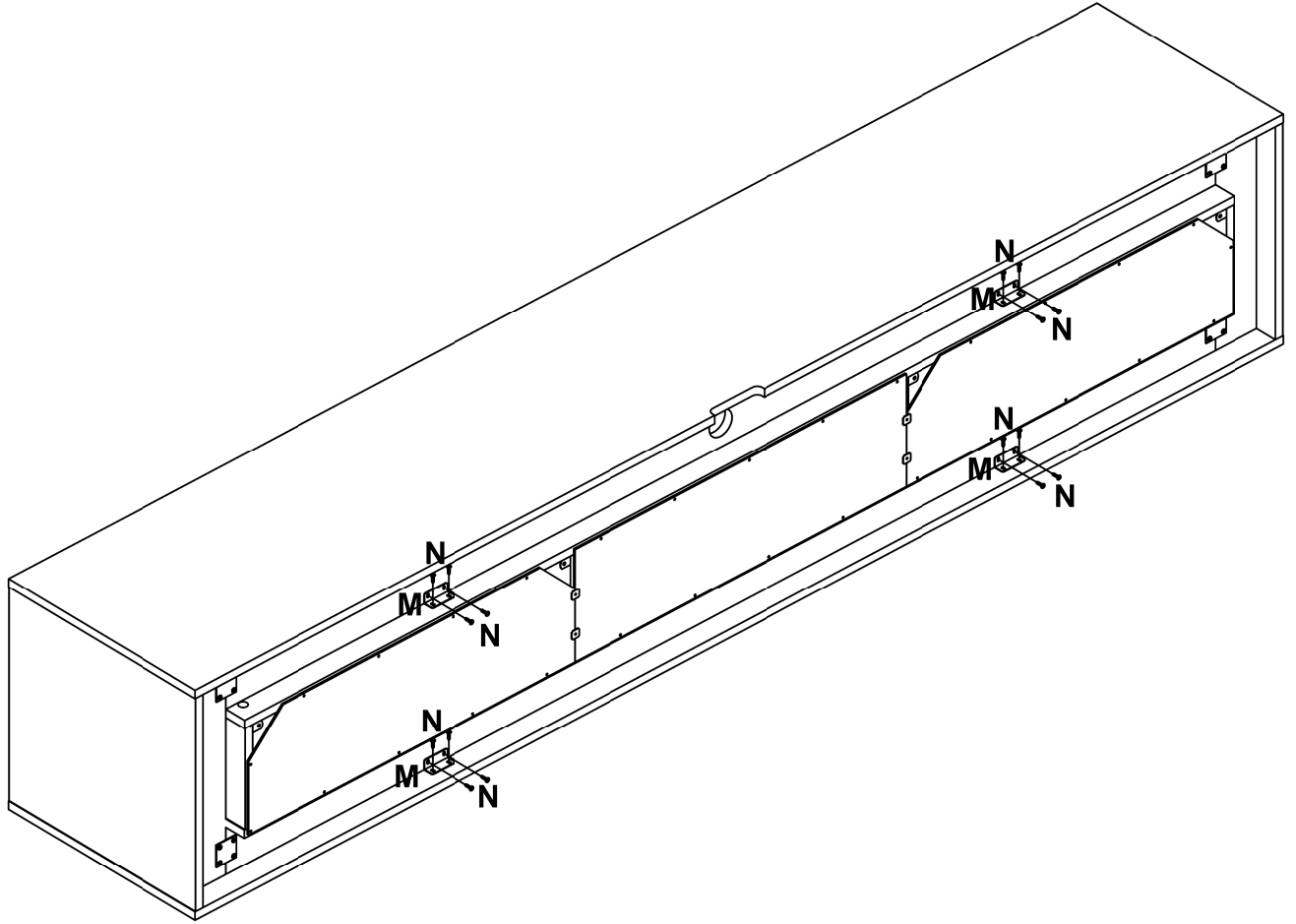

M09 -

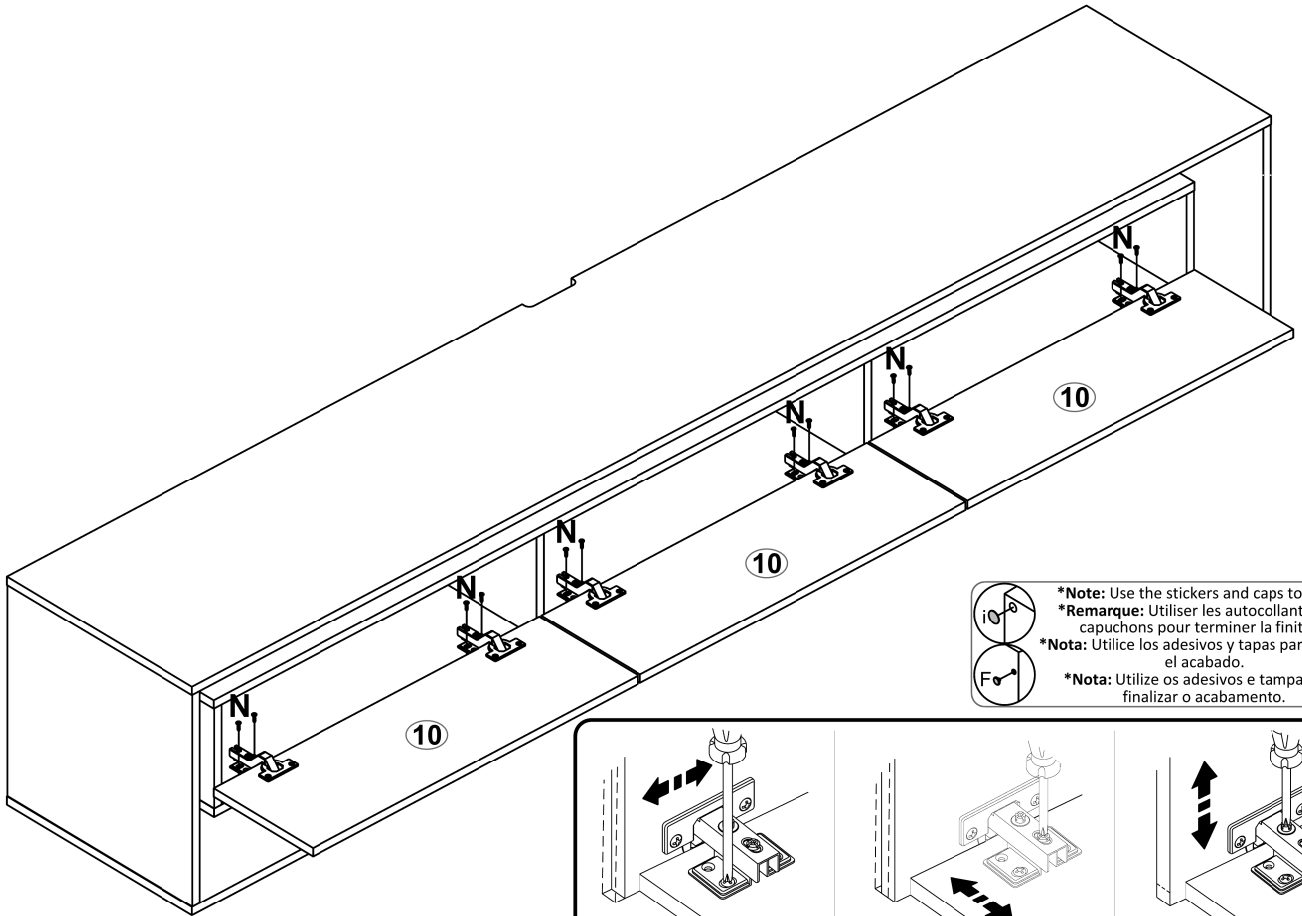

M10 -



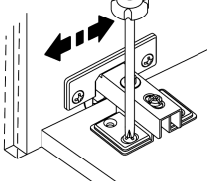
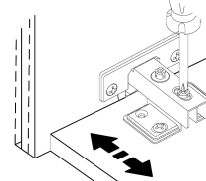
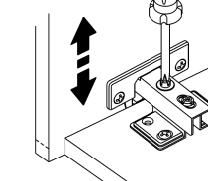

**\*Note:** Use the stickers and caps to finish.  
**\*Remarque:** Utiliser les autocollants et les capuchons pour terminer la finition.  

**\*Nota:** Utilice los adhesivos y tapas para finalizar el acabado.  
**\*Nota:** Utilize os adesivos e tampas para finalizar o acabamento.

		
<p>Horizontal Adjustment Regulagem Horizontal Ajuste Horizontal Ajuste Horizontal</p>	<p>Depth Adjustment Regulagem Profundidade Ajuste Profundidad Ajuste de Profundidade</p>	<p>Vertical Adjustment Regulagem Vertical Ajuste Vertical Ajuste Vertical</p>

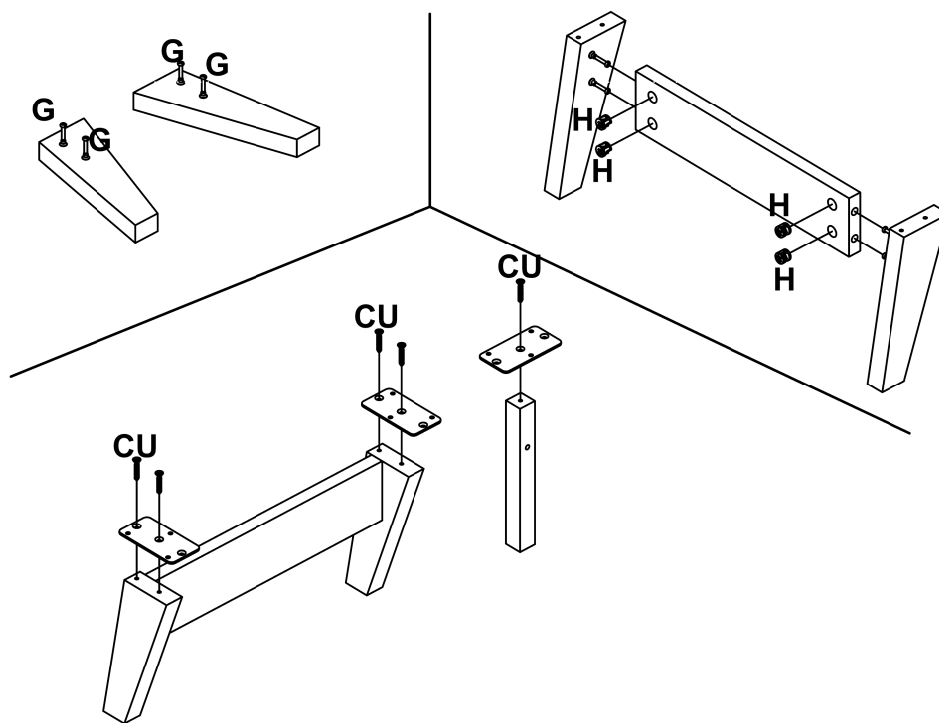
M11 -

# MONTAGEM DO RACK COM PÉS EM MADEIRA



M12 -

