

kappesberg

Manual de Montagem
Instrucciones de Montaje / Assembly Instructions

ARM006

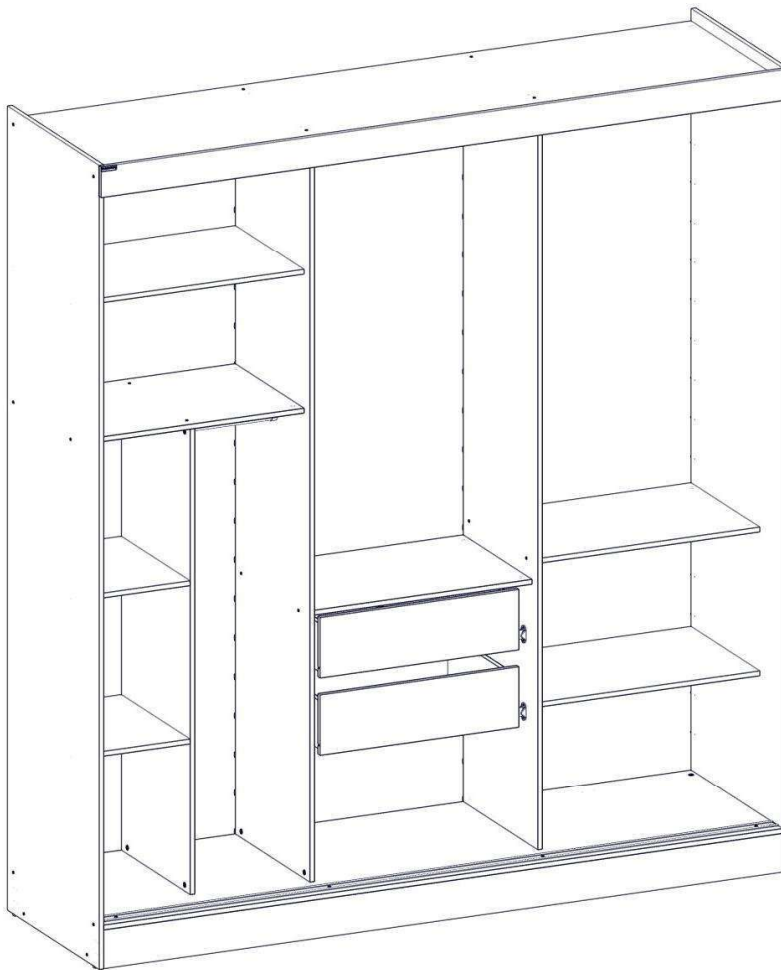

Imagens meramente ilustrativas
Imágenes ilustrativas/Images merely illustrative.

INSTRUÇÕES PARA A MONTAGEM
INSTRUCCIONES DE MONTAJE
ASSEMBLY INSTRUCTIONS

Para realizar a montagem são necessárias **2 pessoas**.

Para realizar el montaje, se necesitan **2 personas**.

To assemble it, **2 people** are required.

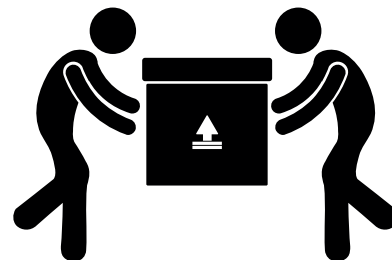

Ferramentas necessárias realizar a montagem.
Ferramentas **NÃO** fornecidas.

Herramientas necesarias para el montaje.
Herramientas **NO** proporcionadas.

Tools required for assembly.
Tools **NOT** provided.

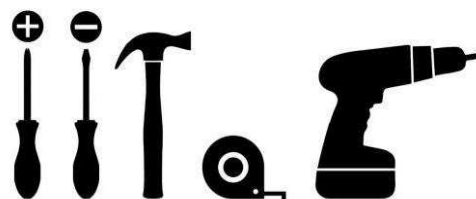

PERIGO DE ASFIXIA - Este produto contém peças pequenas, mantenha fora do alcance das crianças.

PELIGRO DE ASFIXIA - Este producto contiene piezas pequeñas. Mantener fuera del alcance de los niños.

CHOKING HAZARD - This product contains small parts. Keep out of reach of children.



Em caso de dúvida, entre em contato com nosso atendimento:

En caso de duda, comuníquese con nuestro servicio de atención al cliente:

If in doubt, contact our customer service:

+55 51 2500 7800

www.kappesberg.com.br



INSTRUÇÕES PARA A MONTAGEM
INSTRUCCIONES DE MONTAJE
ASSEMBLY INSTRUCTIONS

Siga atentamente os passos de montagem indicados no manual.

Siga atentamente los pasos de montaje indicados en el manual.

Follow the assembly steps carefully as indicated in the manual.



Antes de começar a montagem, identifique e separe todas as peças e acessórios.

Antes de comenzar el montaje, identifique y separe todas las piezas y accesorios.

Before starting the assembly, identify and separate all the parts and accessories.



Durante a montagem, mantenha peças e acessórios organizados para evitar acidentes.

Durante el montaje, mantenga las piezas y accesorios organizados para evitar accidentes.

During assembly, keep parts and accessories organized to avoid accidents.



Para proteger seu móvel, faça a montagem sobre uma superfície limpa e plana.

Dica: Você pode utilizar a embalagem do produto para forrar o espaço onde será feita a montagem.

Para proteger su mueble, realice el montaje sobre una superficie limpia y plana.

Consejo: Puede utilizar el embalaje del producto para forrar el área donde se realizará el montaje.

To protect your furniture, assemble it on a clean and flat surface.

Tip: You can use the product packaging to line the area where the assembly will be done.



PEÇAS - PIEZAS - PARTS

QTD.	CÓDIGO / CODE	DESCRIÇÃO	DESCRIPCIÓN	DESCRIPTION	C x L x E	L x W x T
1	P107754	LATERAL ESQUERDA	LADO IZQUERDA	LEFT SIDE	2000 x 512 x 12 mm	78.74 x 20.16 x 0.47 in
1	P107755	DIVISORIA	DIVISION	DIVISION	1849 x 416 x 12 mm	72.80 x 16.38 x 0.47 in
2	P107763	RODAPE INTERNO	ZOCALO INTERNO	INTERNAL BASEBOARD	460 x 96 x 12 mm	18.11 x 3.78 x 0.47 in
2	P107765	PRATELEIRA SOLTA	ESTANTE	SHELF	584 x 384 x 12 mm	22.99 x 15.12 x 0.47 in
1	P107766	TAMPO	TAPA	TOP	584 x 384 x 12 mm	22.99 x 15.12 x 0.47 in
1	P107767	DIVISORIA	DIVISION	DIVISION	1158 x 384 x 12 mm	45.59 x 15.12 x 0.47 in
2	P107768	PRATELEIRA SOLTA	ESTANTE	SHELF	286 x 384 x 12 mm	11.26 x 15.12 x 0.47 in
2	P107769	CABECEIRA DE GAVETA	CABEZAL DEL CAJÓN	DRAWER HEAD	485 x 120 x 12 mm	19.09 x 4.72 x 0.47 in
4	P107770	LATERAL DE GAVETA	LADO DEL CAJÓN	DRAWER SIDE	360 x 120 x 12 mm	14.17 x 4.72 x 0.47 in
2	P107771	FUNDO DE GAVETA	FONDO DEL CAJÓN	DRAWER BOTTOM	501 x 361 x 3 mm	19.72 x 14.21 x 0.12 in
2	P107772	FRENTE DE GAVETA	FRENTE DEL CAJÓN	DRAWER FRONT	520 x 150 x 12 mm	20.47 x 5.91 x 0.47 in
2	P107773	TAMPO	TAPA	TOP	584 x 384 x 12 mm	22.99 x 15.12 x 0.47 in
1	P107792	CHAPÉU	SOMBRERO	HAT	1776 x 512 x 12 mm	69.92 x 20.16 x 0.47 in
1	P107793	BASE	BASE	BASE	1776 x 512 x 12 mm	69.92 x 20.16 x 0.47 in
1	P107794	RODAFORRO	MARCO SUPERIOR	UPPER FRAME	1801 x 76 x 12 mm	70.91 x 2.99 x 0.47 in
1	P107795	RODAPE	ZOCALO	BASEBOARD	1776 x 96 x 12 mm	69.92 x 3.78 x 0.47 in
1	P107796	RODAPE	ZOCALO	BASEBOARD	1776 x 96 x 12 mm	69.92 x 3.78 x 0.47 in
1	P107797	LATERAL DIREITA	LADO DIRECTO	RIGHT SIDE	2000 x 512 x 12 mm	78.74 x 20.16 x 0.47 in
1	P107799	DIVISORIA	DIVISION	DIVISION	1849 x 416 x 12 mm	72.80 x 16.38 x 0.47 in

PEÇAS - PIEZAS - PARTS

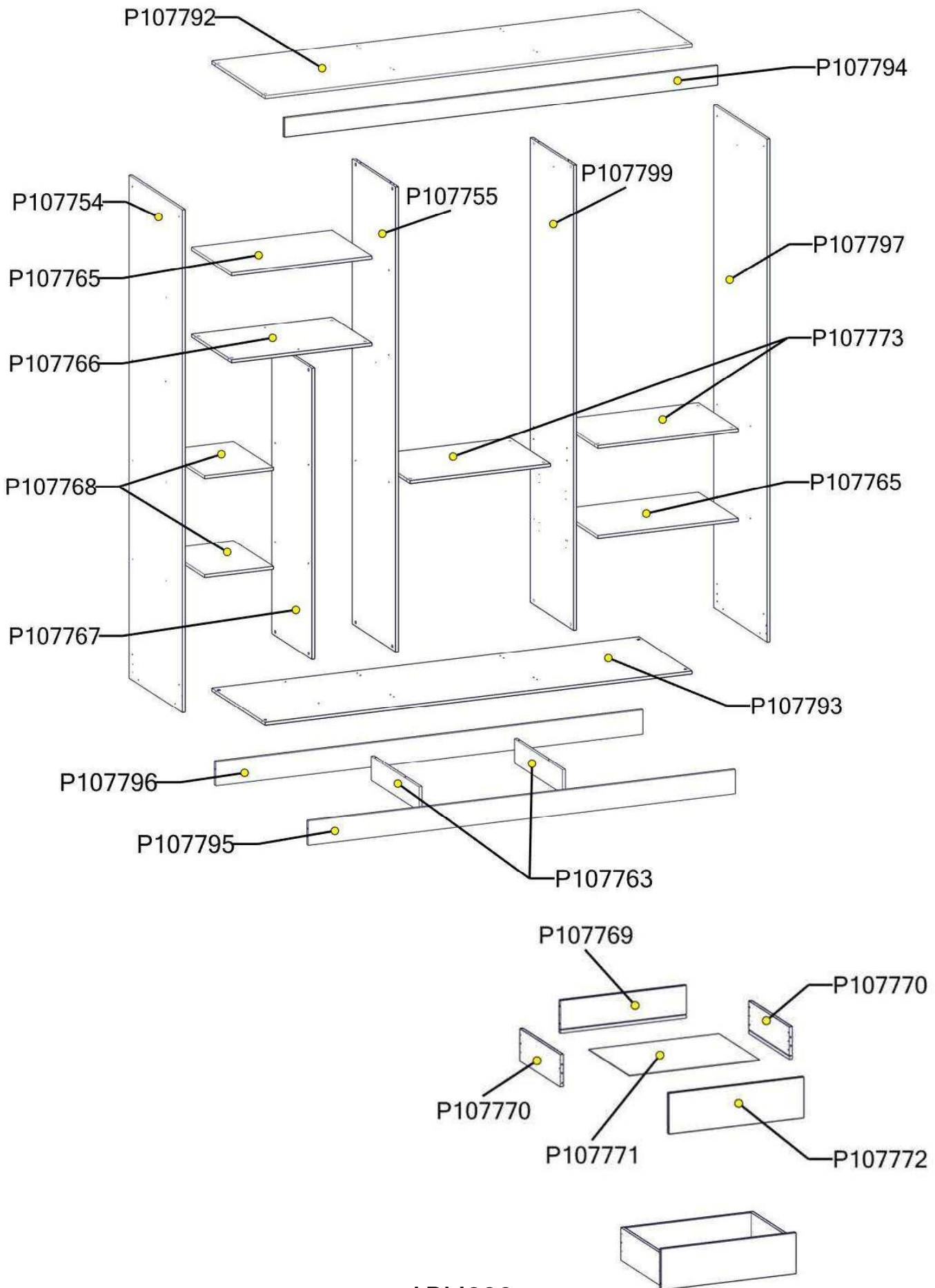









ACESSÓRIOS - ACCESORIOS - ACCESSORIES

Em caso de dúvida sobre o tamanho do parafuso, você pode utilizar a régua ilustrada abaixo para verificar a medida exata.

En caso de duda sobre el tamaño del tornillo, puede utilizar la regla ilustrada abajo para verificar la medida exacta.

In case of doubt about the screw size, you can use the ruler illustrated below to check the exact measurement.

	QTD.	CÓDIGO / CODE	DESCRIÇÃO	DESCRIPCIÓN	DESCRIPTION
	122	000107	PREGO 10 X 10	PREGO 10 X 11	NAIL 10 X 10
	8	000108	PREGO 12 X 12	PREGO 12 X 13	NAIL 12 X 12
	40	000226	P.CHATO 4,0 X 40 CAB. PHILLIPS	TORNILLO 4X40MM	SCREW 4X40MM
	4	001178	P.FLANGE 3,5 X 16 CAB. PHILLIPS	TORNILLO 3,5 X 16	SCREW 3,5 X 16
	4	005256	P.CHATO 4,0 X 20 CAB. PHILLIPS	TORNILLO 4,0 X 20	SCREW 4,0 X 20
	178	030457	P.CHATO 3,5 X 12 CAB. PHILLIPS	TORNILLO 3,5 X 12	SCREW 3,5 X 12
	4	054117	P.CHATO 3,5 X 25 CAB. PHILLIPS	TORNILLO 3,5 X 25	SCREW 3,5 X 25
	14	056243	P.FLANGE 3,5 X 12 CAB. PHILLIPS	TORNILLO 3,5 X 12	SCREW 3,5 X 12

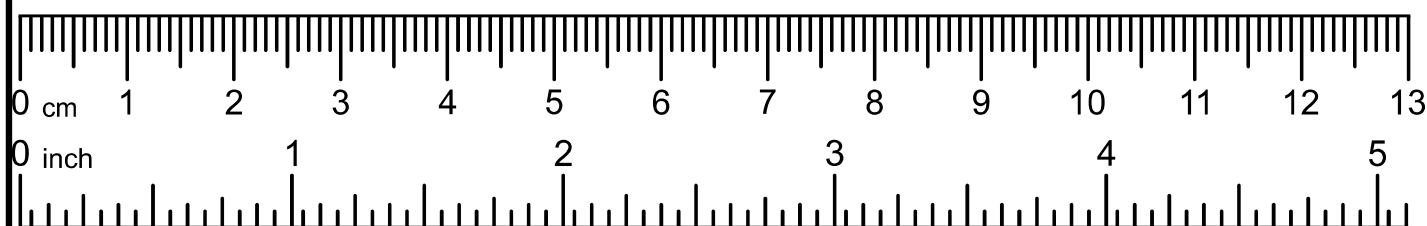

ARM006

6

ACESSÓRIOS - ACCESORIOS - ACCESSORIES

	QTD.	CÓDIGO / CODE	DESCRIÇÃO	DESCRIPCIÓN	DESCRIPTION
	1	000041	COLA BRANCA EM BISNAGA (10GR)	COLA BRANCA EM BISNAGA (10GR)	GLUE
	16	000118	SUP. P/ PRAT. 6 X 8MM	SOPORTE DE ESTANTE 6 X 8	SHELF SUPPORT 6 X 8
	24	000899	CANTONEIRA PLÁSTICA	CANTONERA	PLASTIC SUPPORT
	40	001423	FIXADOR DE COSTA	FIJADOR DE ESPALDA	BACK FIXER
	8	001482	AFASTADOR DE GAVETA 25MM	SEPARADOR DE CAJÓN 25MM	DRAWER DIVIDER 25MM
	28	001802	CAVILHA 6 X 30MM	TARUGO 6X30MM	DOWEL 6X30MM
	8	001901	SAPATA DESLIZADORA PRETA 15 X 6MM	ZAPATO 15 X 6	SHOE 15 X 6
	4	001925	CAVILHA 6 X 50MM	TARUGO 6 X 50MM	DOWEL 6 X 50MM
	4	018458	SUPORE TRIANGULAR	SOPORTE TRIANGULO	TRIANGLE SUPPORT
	32	022973	PORCA CILÍNDRICA 12X9MM	TUERCA CILÍNDRICA 12X9MM	CYLINDRICAL NUT 12X9MM
	6	041921	SUP. P/ CABIDEIRO OBLONGO	SOPORTE PERCHA	CLOTHES RACK
	1	075900	ETIQUETA MARCA KAPPESBERG 40 X 12MM	ETIQUETA KAPPESBERG	ETIQUETTE KAPPESBERG
	6	076029	CARRINHO C/ROLDANA CONCAVA P/PORTA DE CORRER	CARRO DE PUERTA CORREDERA	SLIDING DOOR TROLLEY
	6	076030	GUIA SUPERIOR 26MM P/PORTA DE CORRER	GUÍA PARA PUERTA CORREDERA	GUIDE FOR SLIDING DOOR
	4	076031	FREIO SUPERIOR P/PORTA DE CORRER	FRENO SUPERIOR PARA PUERTA CORREDERA	TOP BRAKE FOR SLIDING DOOR

ACESSÓRIOS - ACCESORIOS - ACCESSORIES

	1	PX1	PUXADOR	TIRADOR DE PUERTA	DOOR HANDLE
	2	PX2	PUX. ARUBA 64MM	TIRADOR EMPOTRADO	RECESSED PULL HANDLE
	2	084115	ROLIÇO OBLONGO 15X25MM ALUMÍNIO 578MM	SOPORTE COLGADOR 578MM	HANGING RAIL 578MM
	1	089859	ROLIÇO OBLONGO 15X25MM ALUMÍNIO 278MM	SOPORTE COLGADOR 278MM	HANGING RAIL 278MM
	1	089860	TRILHO PLÁSTICO 1774MM SUPERIOR	CARRIL DE PLASTICO 1774MM	PLASTIC RAIL 1774MM
	1	089862	TRILHO DE ALUMÍNIO SOBREPUESTO 1774MM	CARRIL DE ALUMÍNIO 1774MM	ALUMINUM RAIL 1774MM
	2 (KIT)	CRM350	CORREDIÇA 350MM	SISTEMA DE CAJONES DESLIZANTES	SLIDING DRAWER SYSTEM

PASSO / PASO / STEP 1

Cód.	Qtde.
000118	6

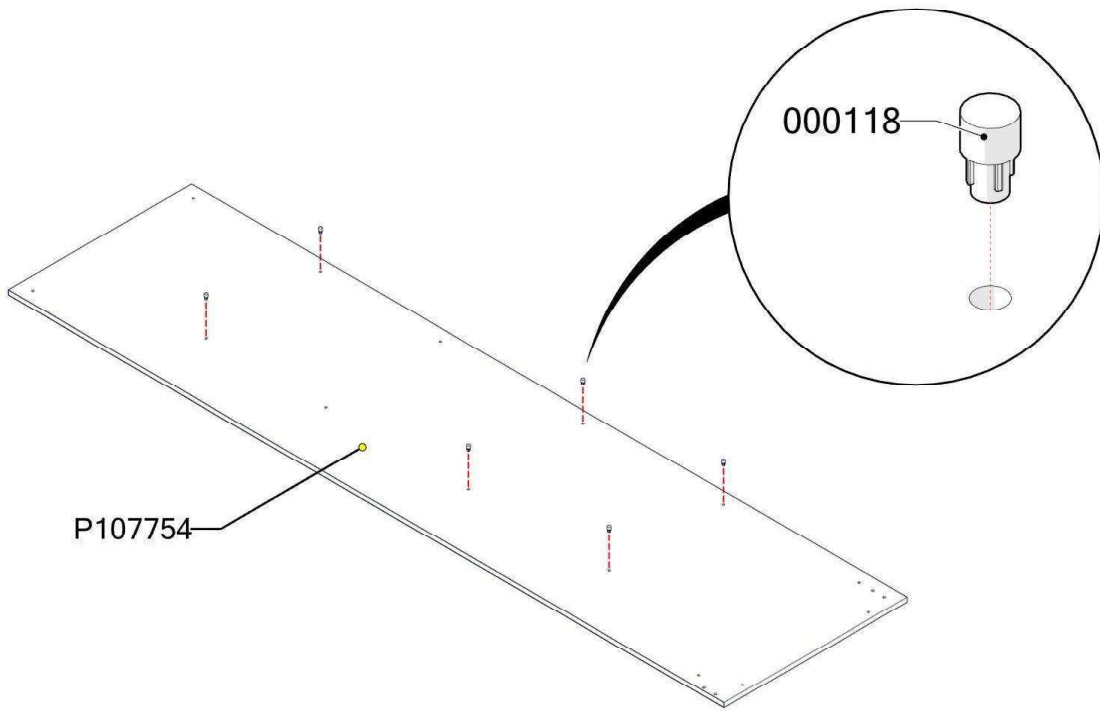

PASSO / PASO / STEP 2 - A

Cód.	Qtde.
000118	4

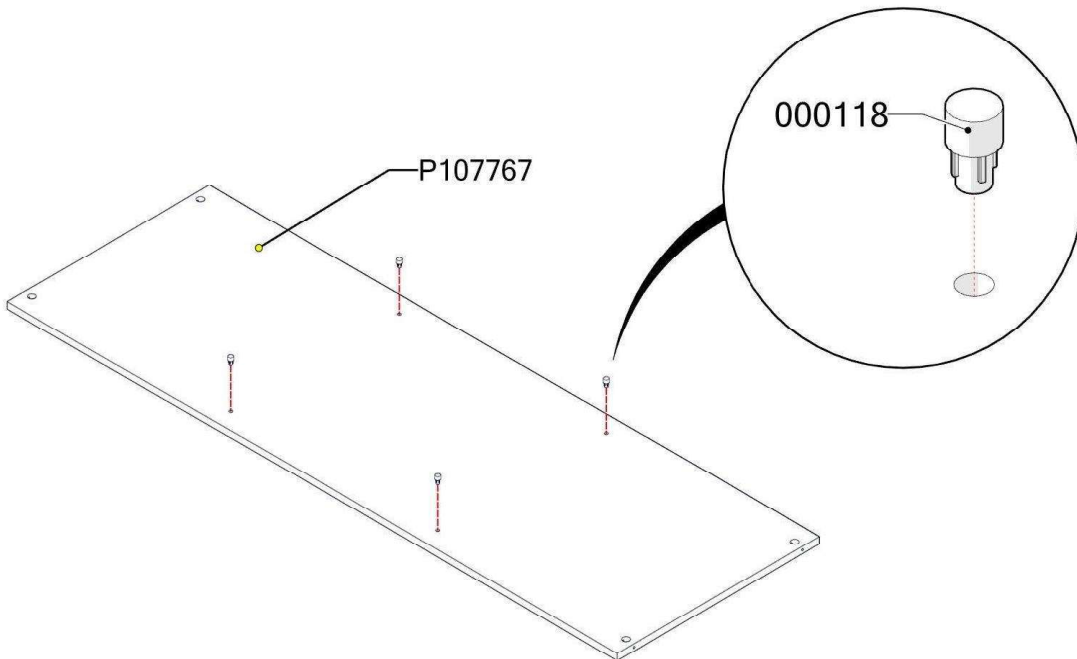

PASSO / PASO / STEP 2 - B

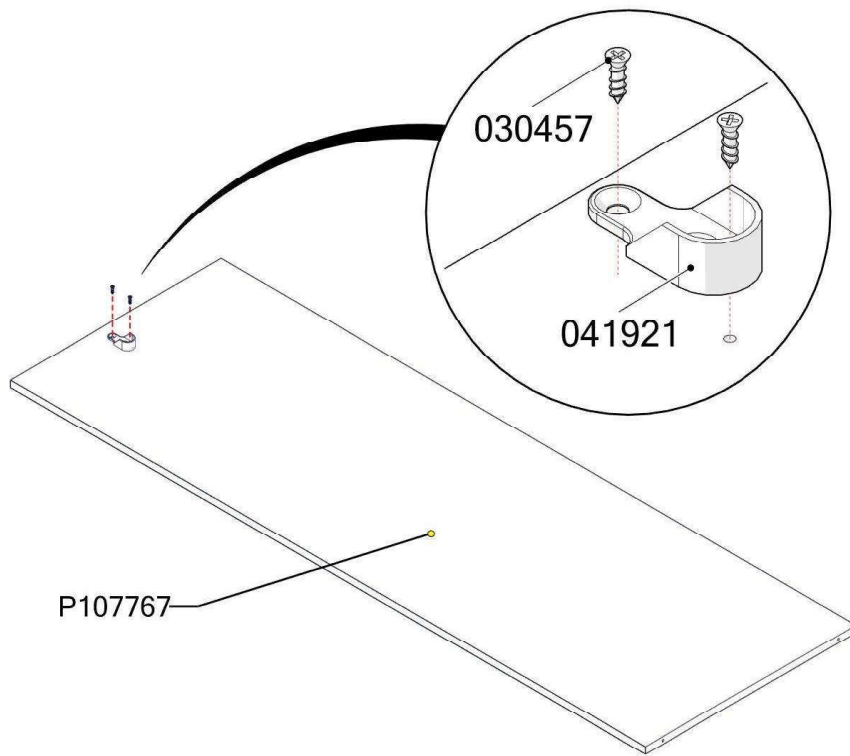

Cód.	Qtde.
030457	2
041921	1

PASSO / PASO / STEP 3 - A

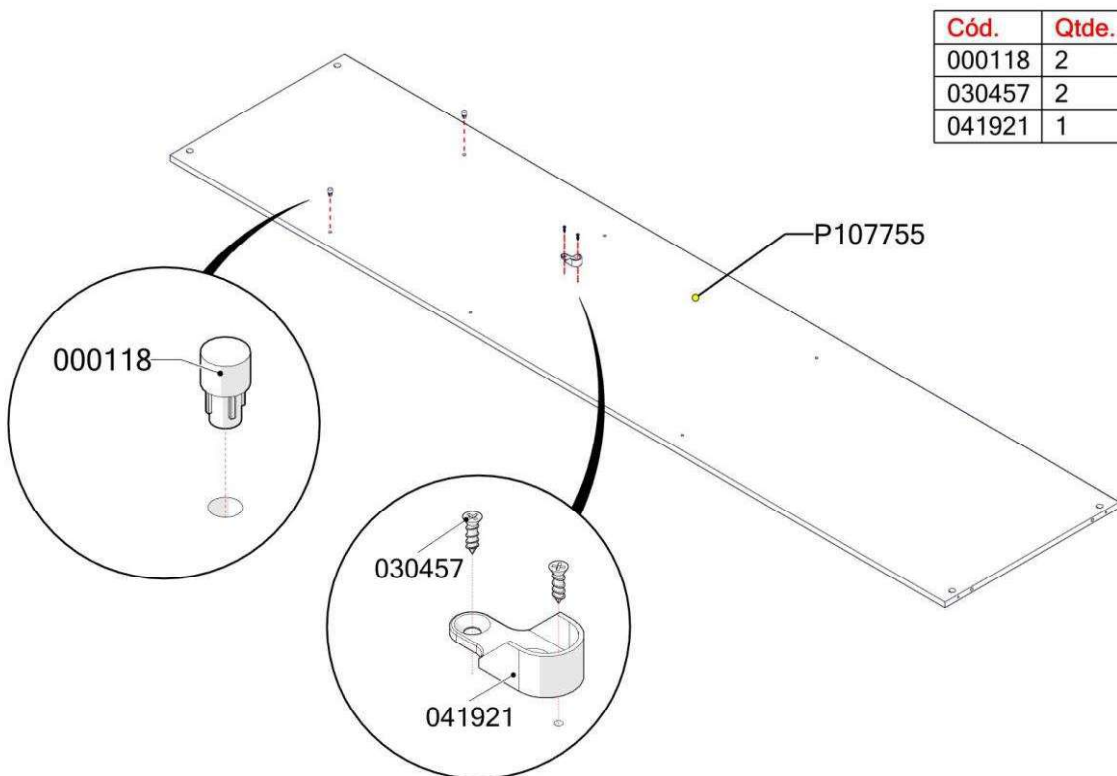

Cód.	Qtde.
000118	2
030457	2
041921	1

PASSO / PASO / STEP 3 - B

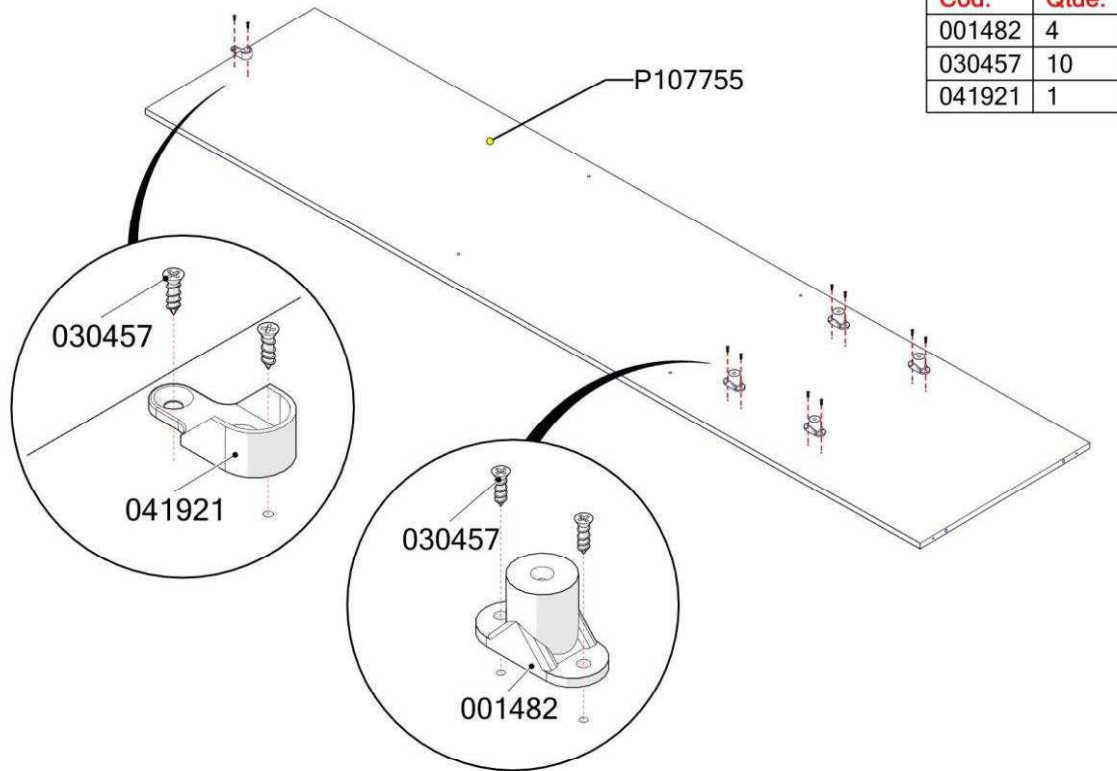

Cód.	Qtde.
001482	4
030457	10
041921	1

PASSO / PASO / STEP 3 - C

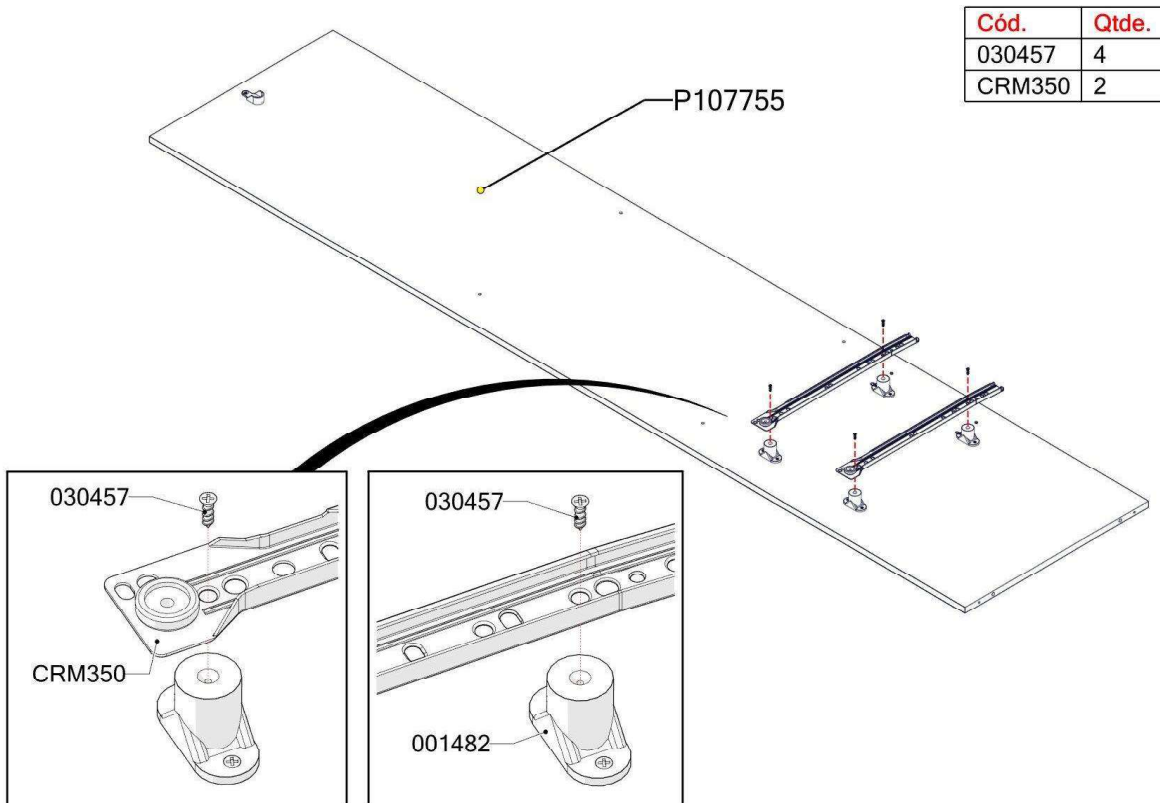

Cód.	Qtde.
030457	4
CRM350	2

ARM006

PASSO / PASO / STEP 3 - D

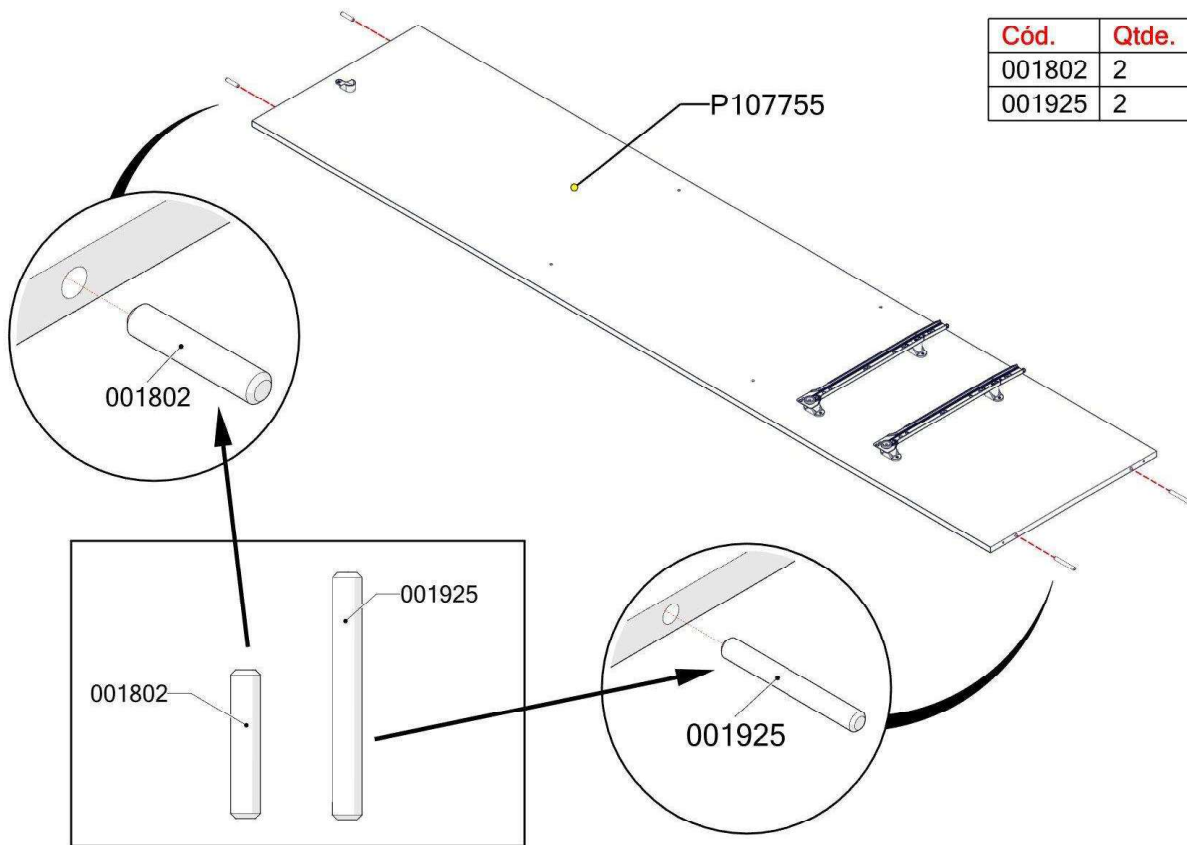

PASSO / PASO / STEP 4 - A

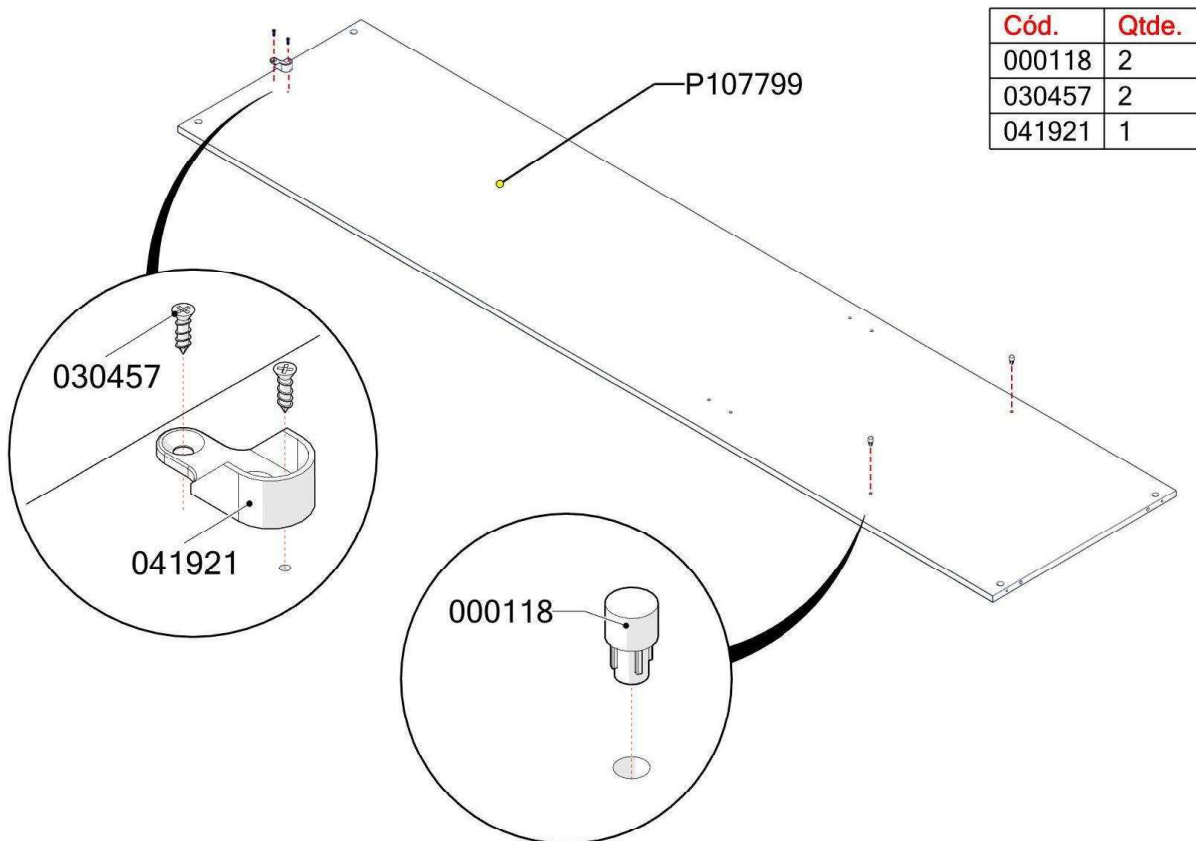

ARM006

PASSO / PASO / STEP 4 - B

Cód.	Qtde.
001482	4
030457	10
041921	1

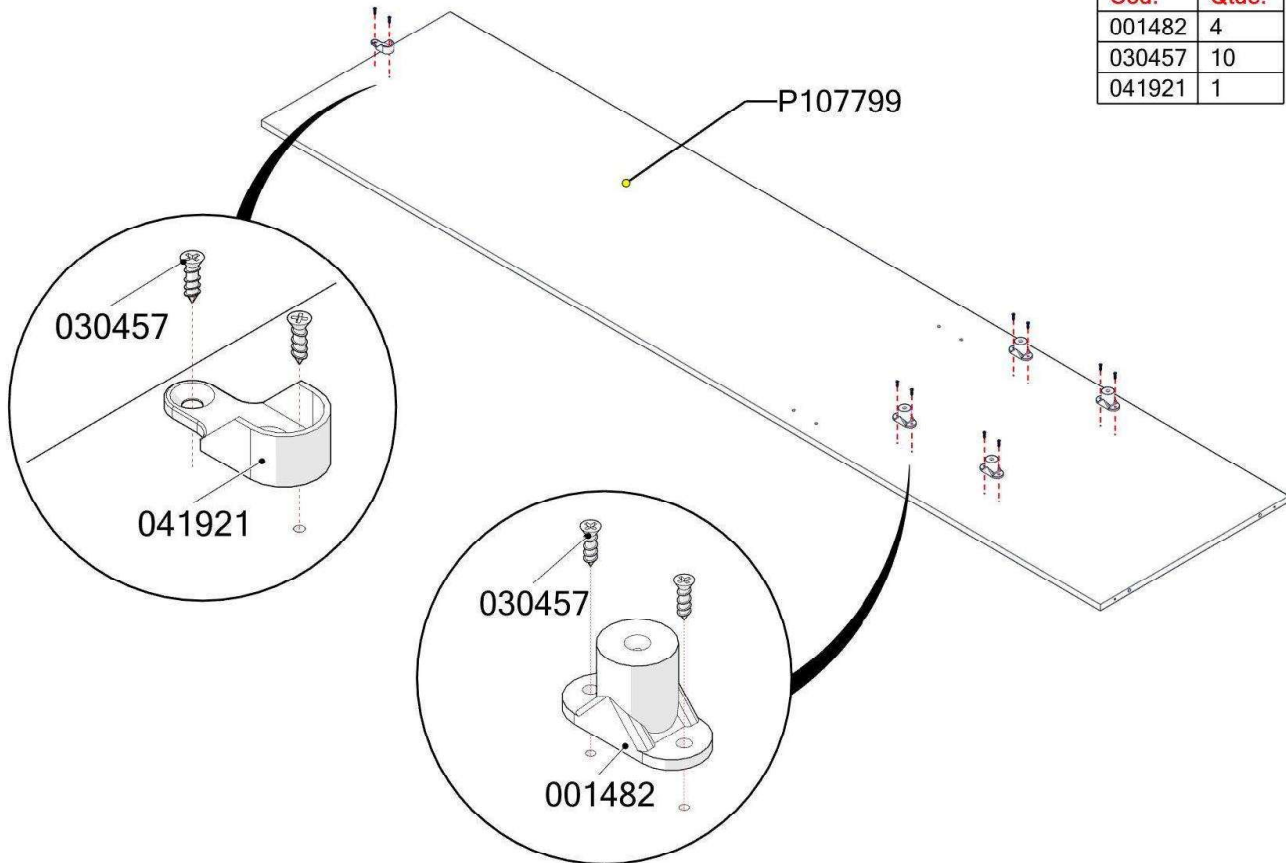

PASSO / PASO / STEP 4 - C

Cód.	Qtde.
030457	4
CRM350	2

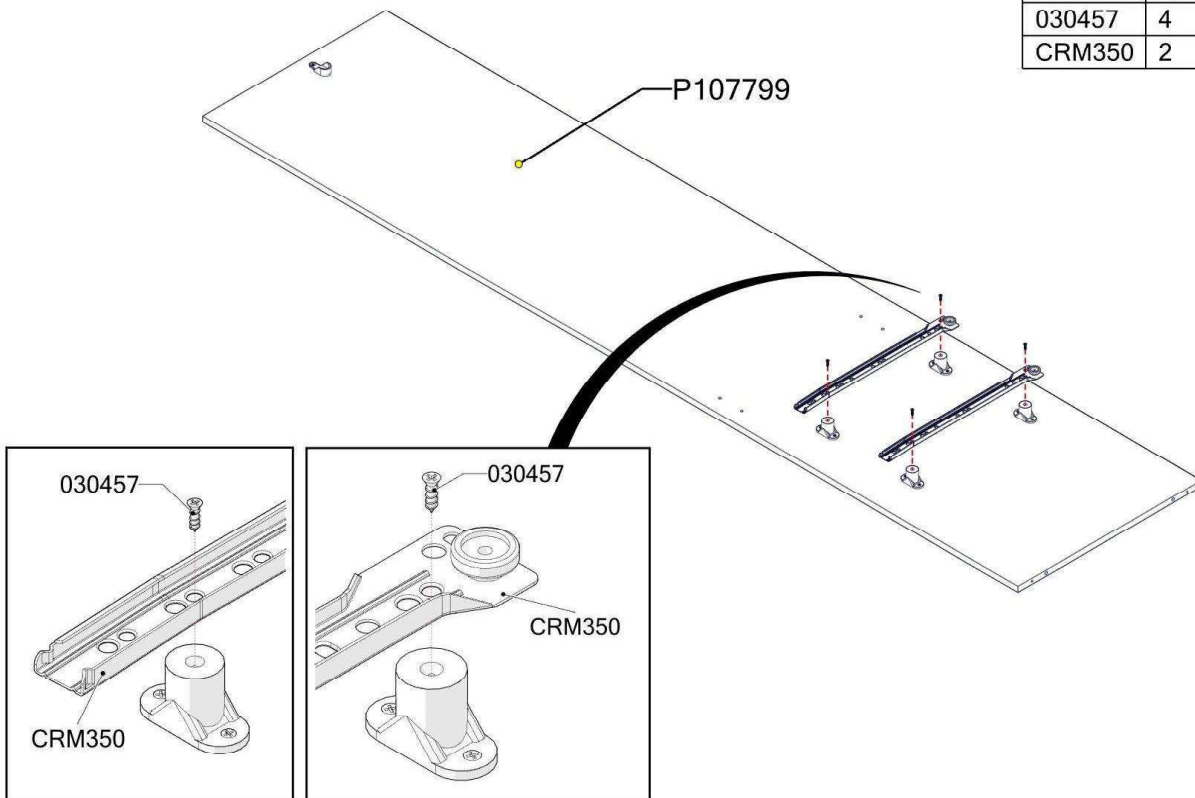

ARM006

PASSO / PASO / STEP 4 - D

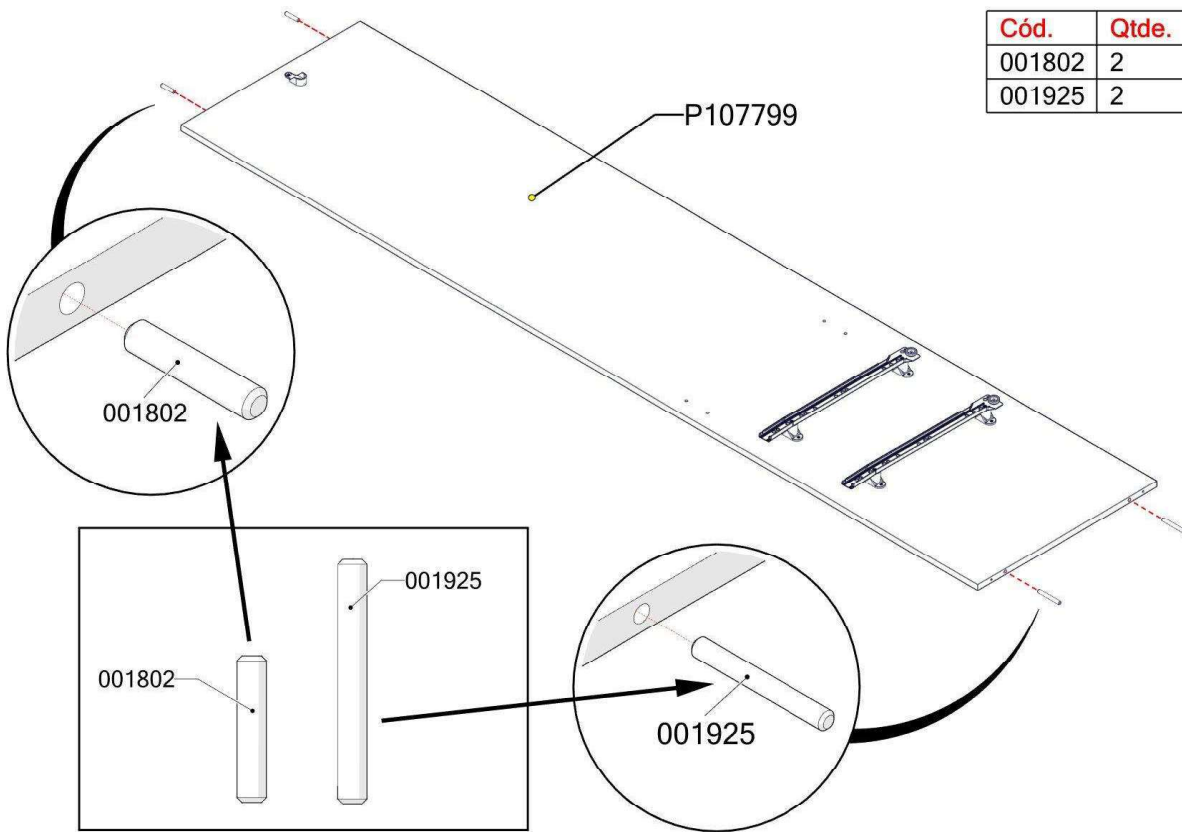

Cód.	Qtde.
001802	2
001925	2

PASSO / PASO / STEP 5

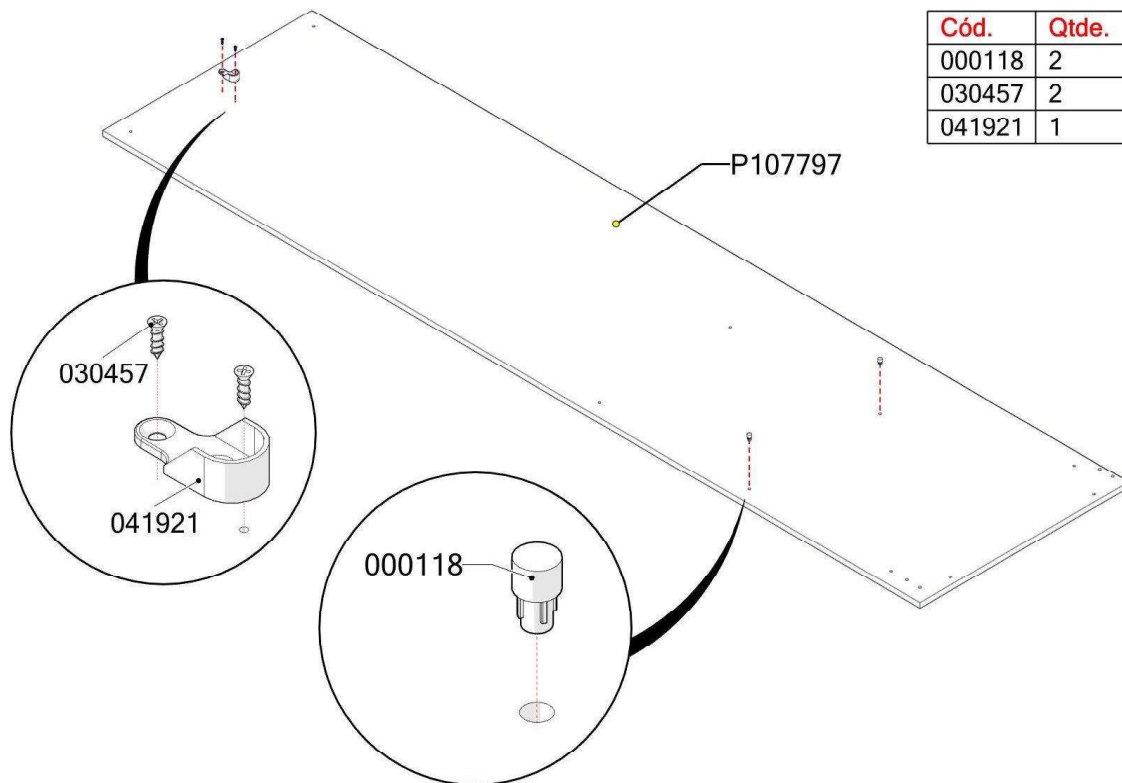

Cód.	Qtde.
000118	2
030457	2
041921	1

ARM006

PASSO / PASO / STEP 6

Cód.	Qtde.
001802	4

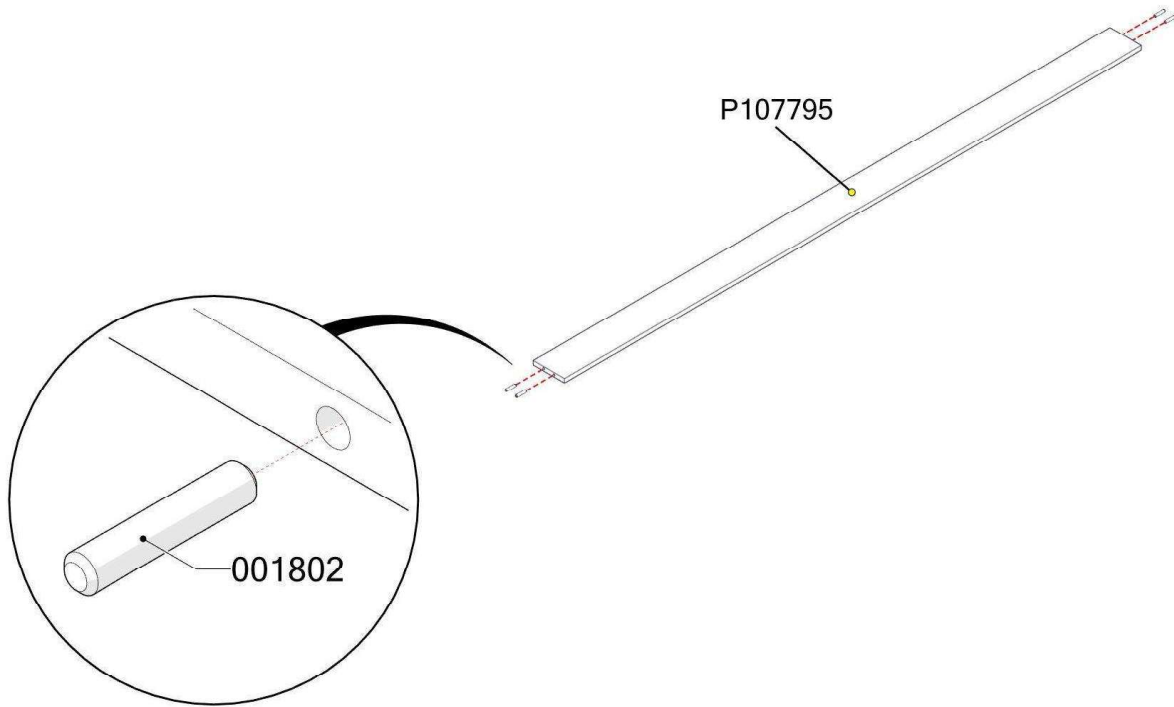

PASSO / PASO / STEP 7

Cód.	Qtde.
001802	4

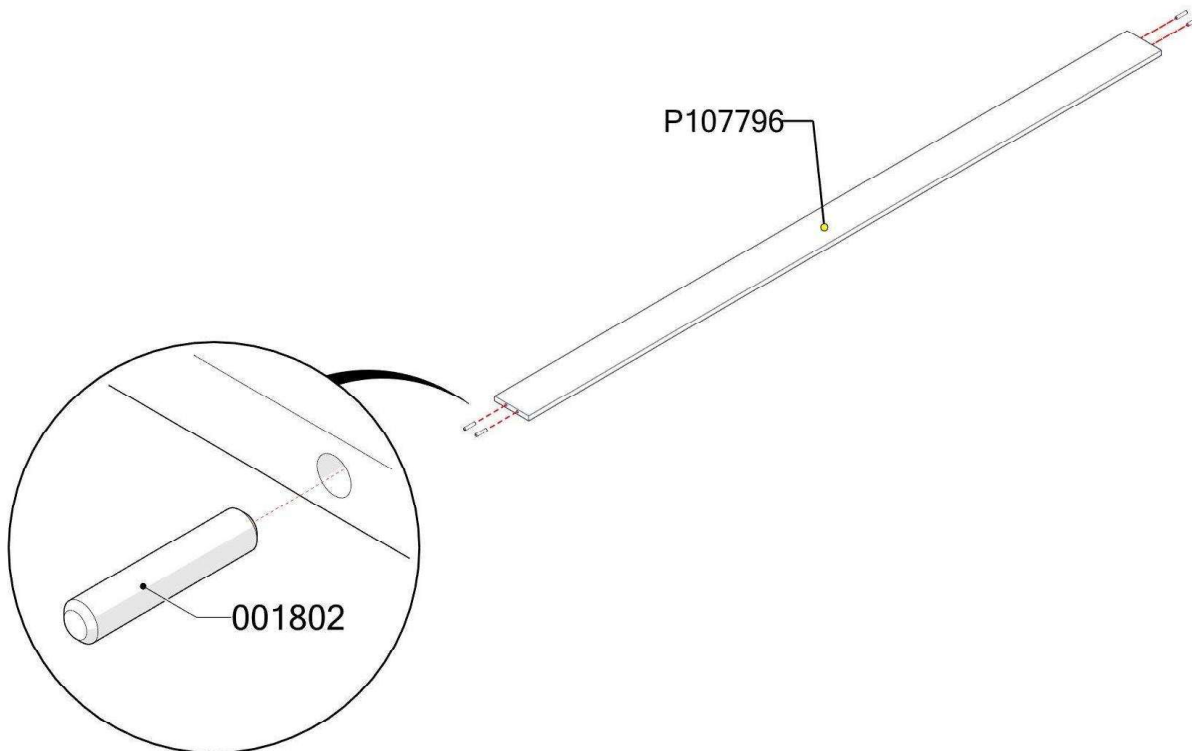

PASSO / PASO / STEP 8

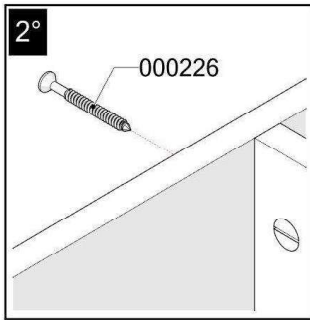
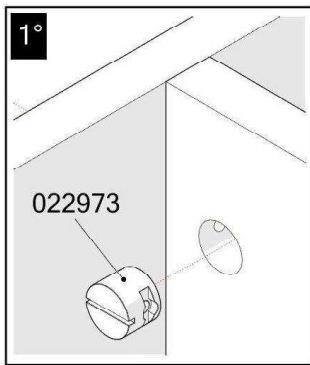

Cód.	Qtde.
000226	4
022973	4

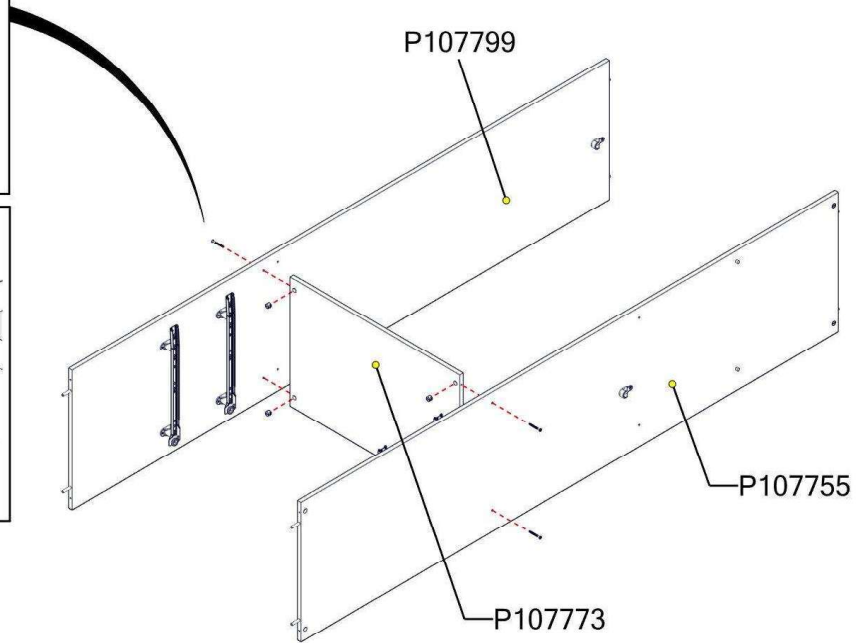

PASSO / PASO / STEP 9

Cód.	Qtde.
000226	4
022973	4

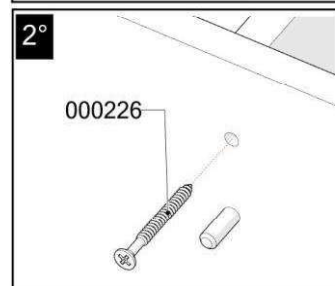
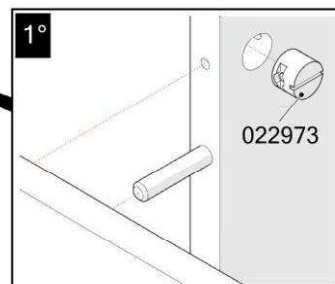
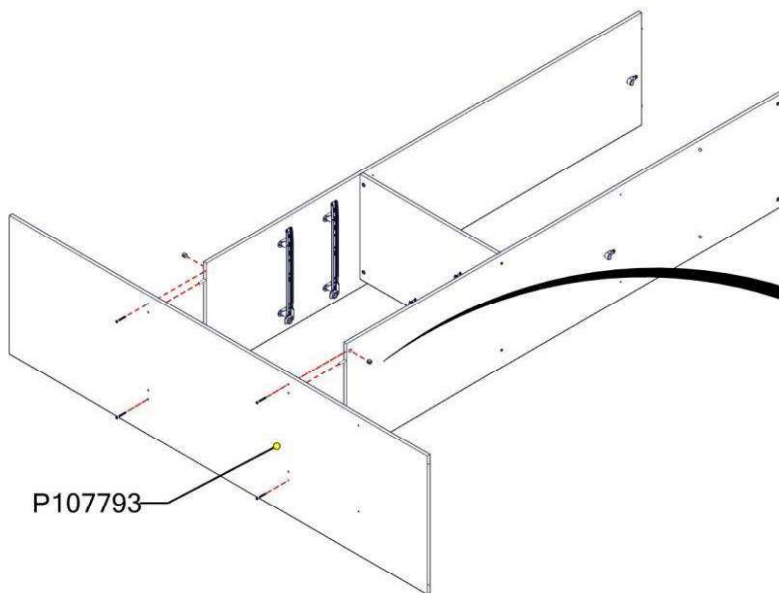

PASSO / PASO / STEP 10

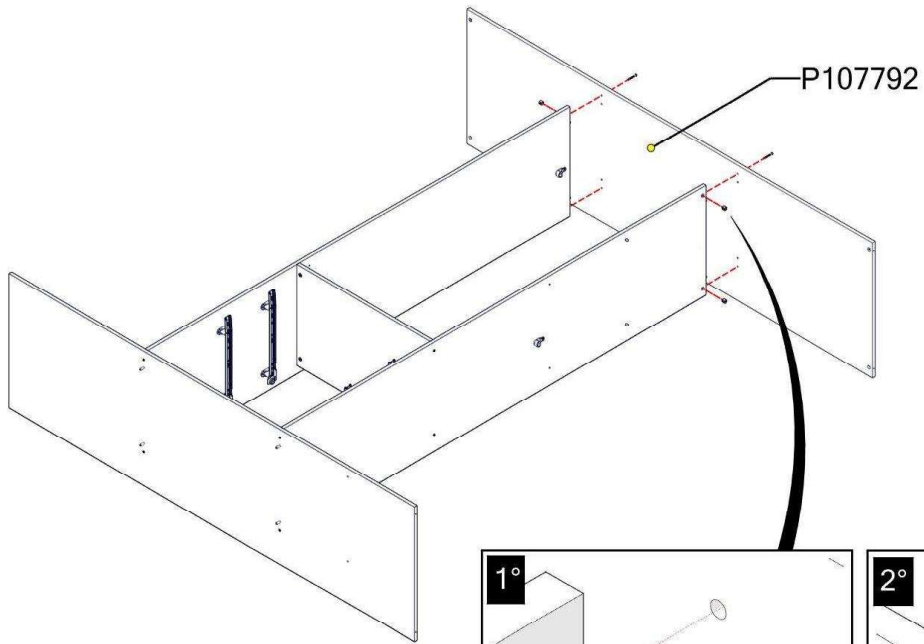

Cód.	Qtde.
000226	4
022973	4

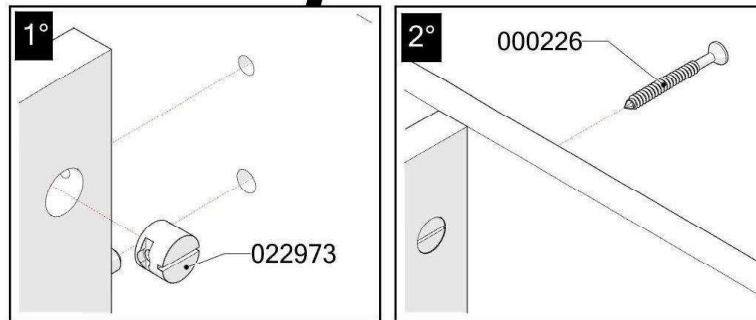

PASSO / PASO / STEP 11

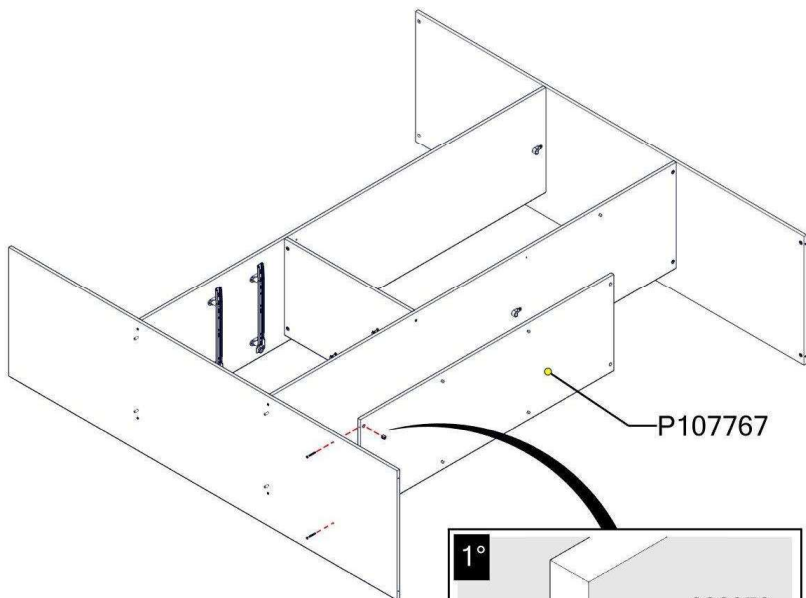

Cód.	Qtde.
000226	2
022973	2

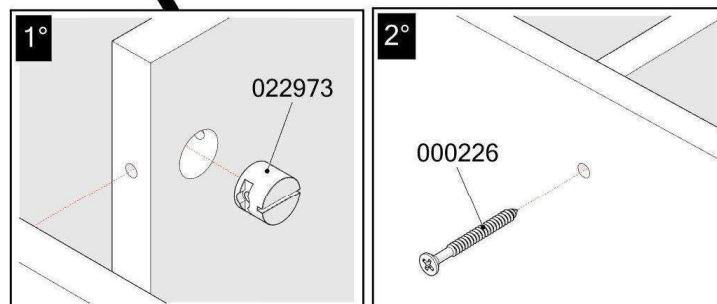

PASSO / PASO / STEP 12

Cód.	Qtde.
000226	4
022973	4

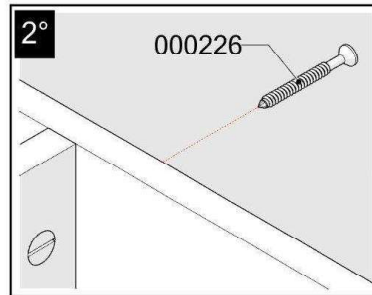
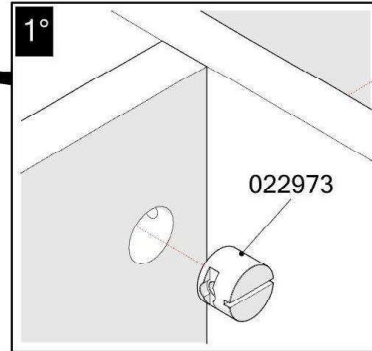
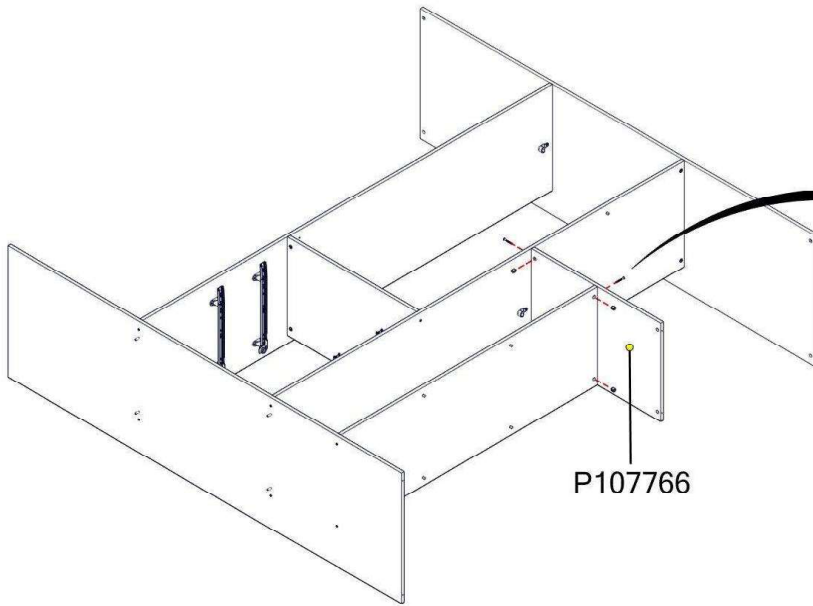

PASSO / PASO / STEP 13

Cód.	Qtde.
000226	6
022973	6

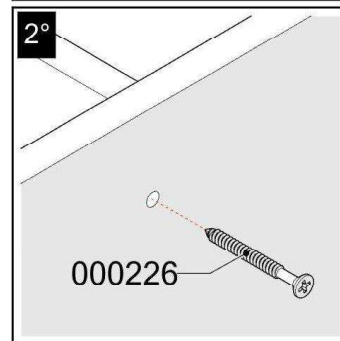
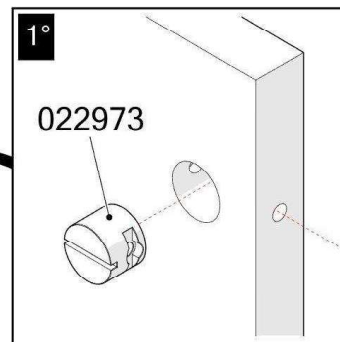
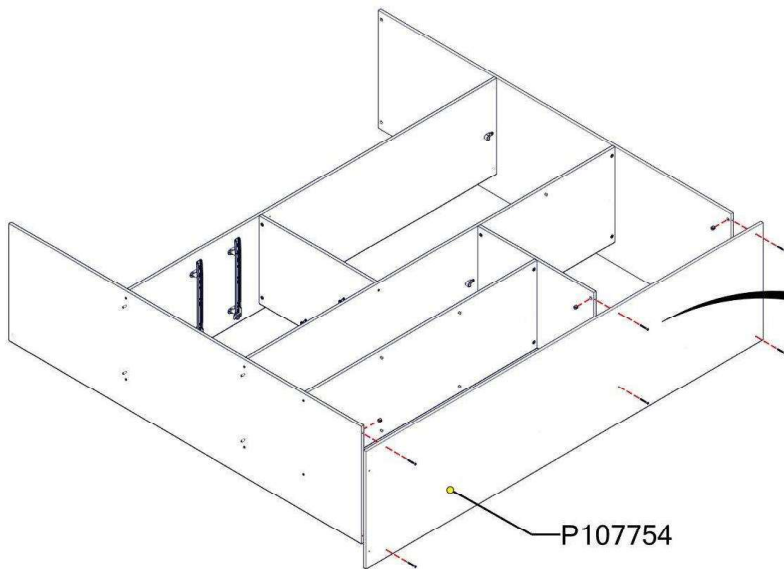

ARM006

PASSO / PASO / STEP 14

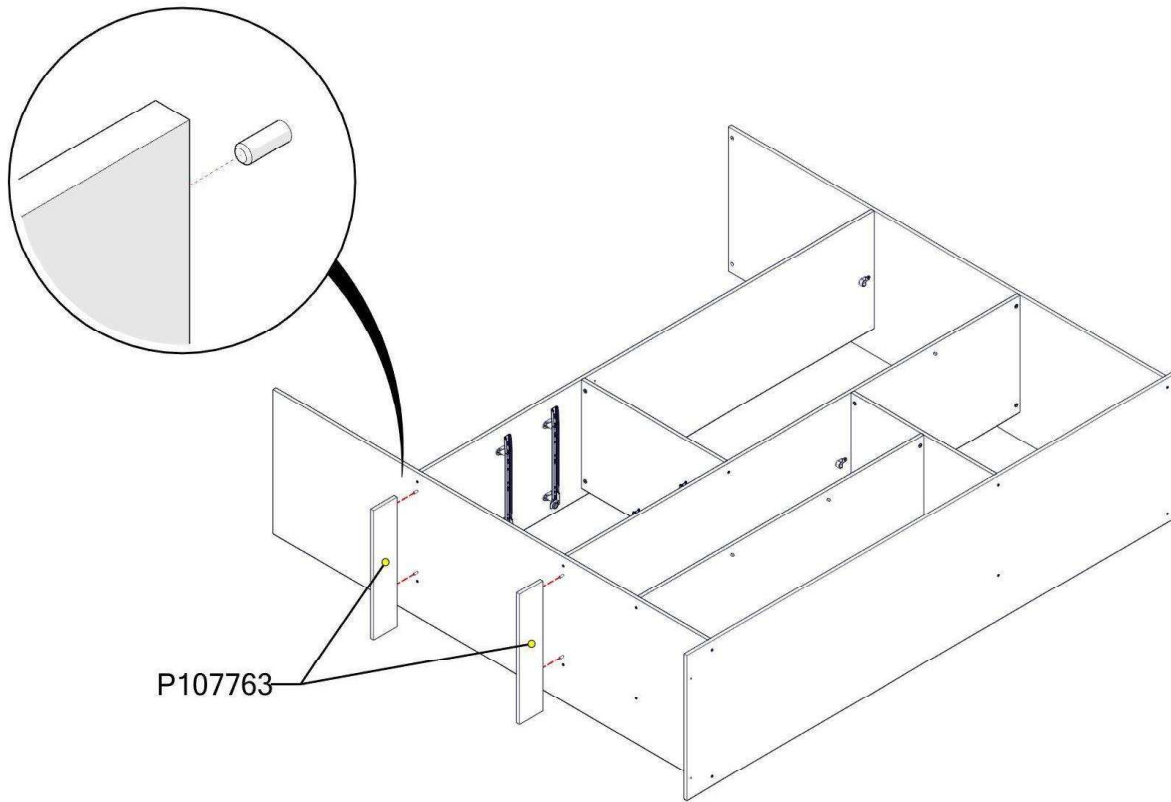

PASSO / PASO / STEP 15

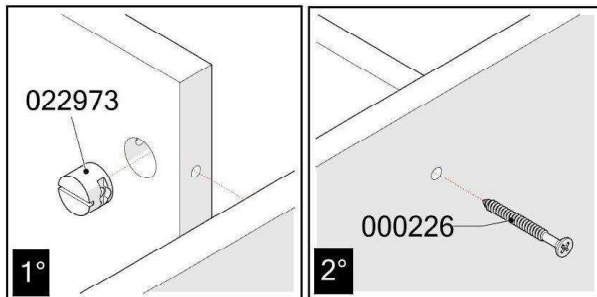

Cód.	Qtde.
000226	2
022973	2

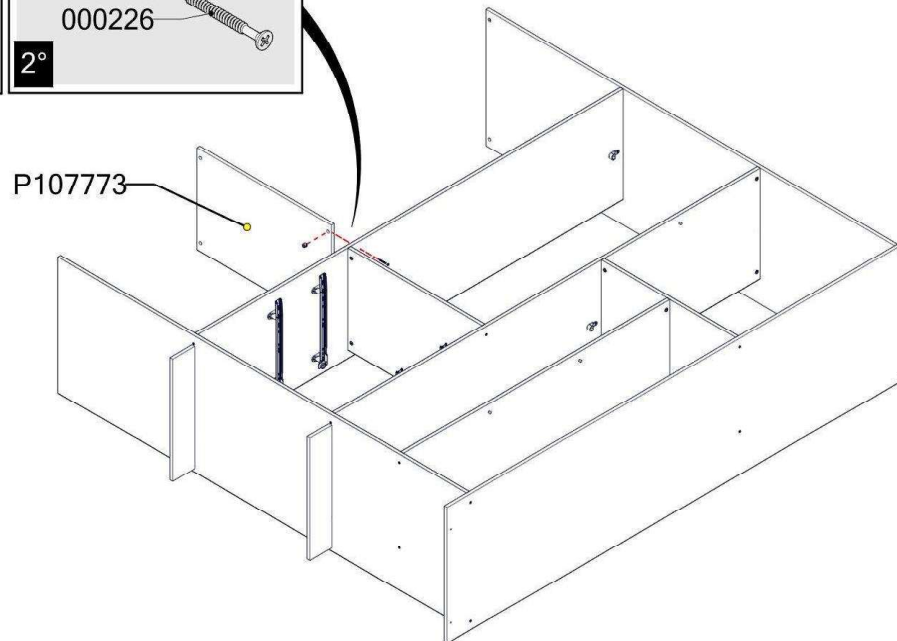

ARM006

PASSO / PASO / STEP 16

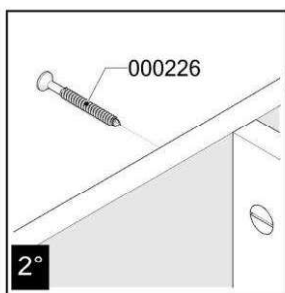
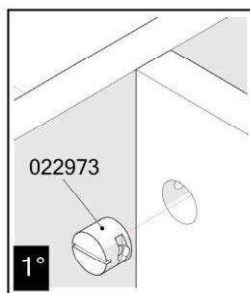

Cód.	Qtde.
000226	6
022973	6

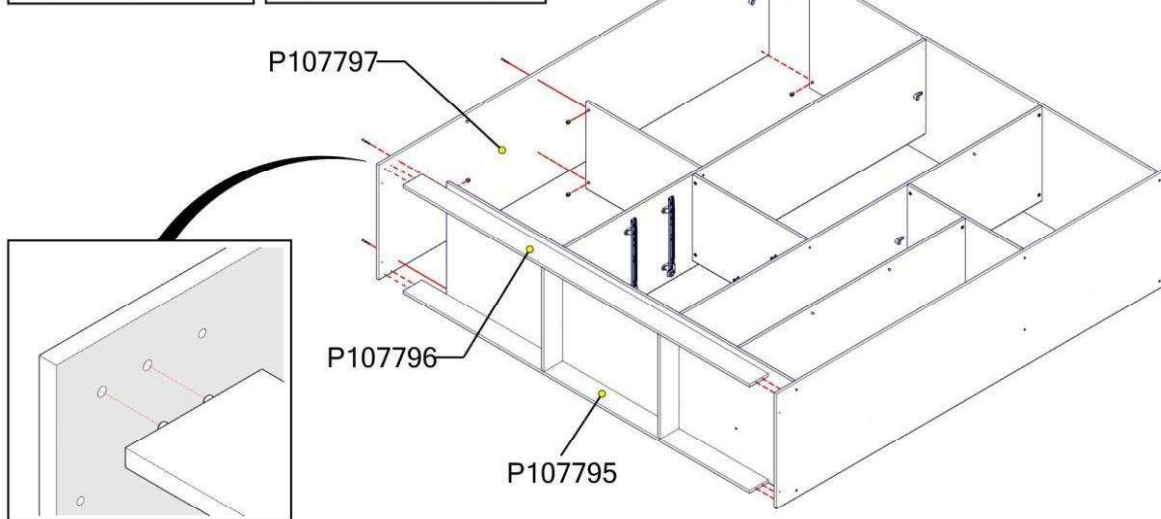

ATENÇÃO / ATENCIÓN / ATTENTION

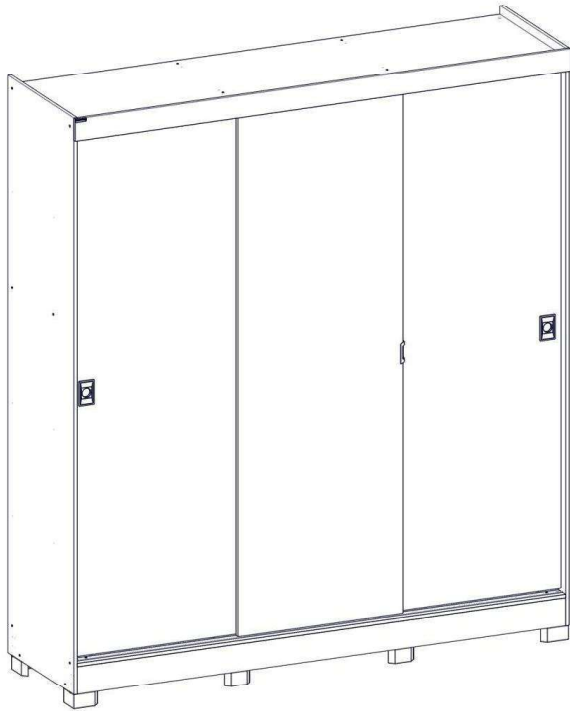

Se adquiriu a opção **COM** pés plásticos, siga as instruções de instalação conforme os **passos 17 e 18**.

Após isso, **desconsidere os passos 19 e 21**.

Si adquirió la opción **CON** pies plásticos, siga las instrucciones de instalación según los **pasos 17 y 18**.

Después de esto, **desconsidere los pasos 19 y 21**.

If you purchased the option **WITH** plastic feet, follow the installation instructions as per steps **17 and 18**.

After that, **disregard steps 19 and 21**.



Se adquiriu, a versão **SEM** pés plásticos desconsidere os passos 17 e 18.

Si adquirió la opción **SIN** pies plásticos, desconsidere los pasos 17 y 18.

If you purchased the option **WITHOUT** plastic feet, disregard steps 17 and 18.

PASSO / PASO / STEP 17

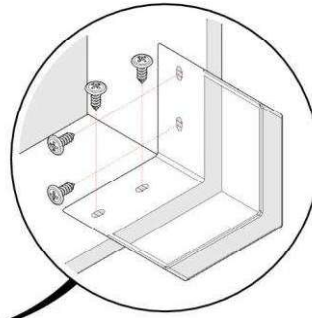
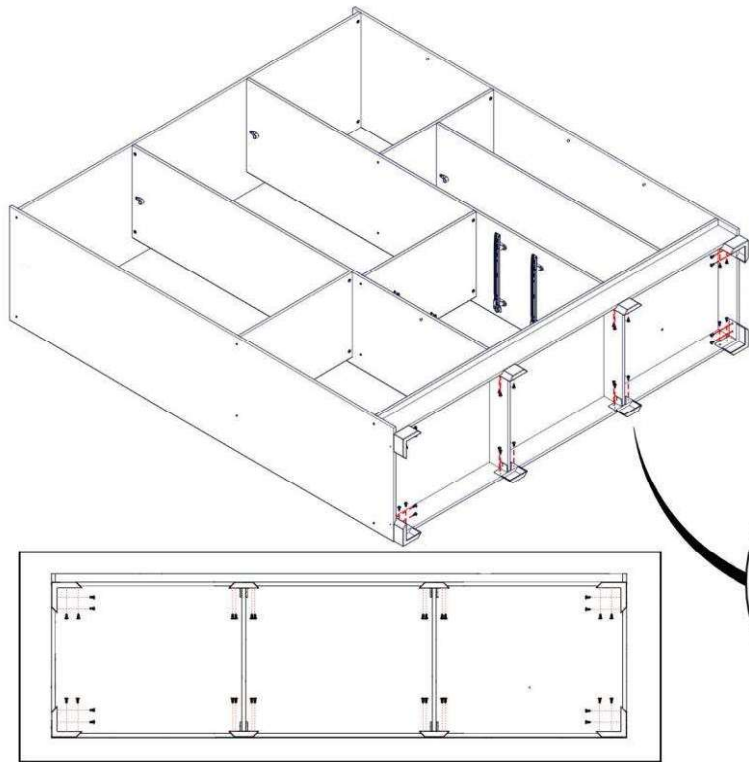

Os parafusos deste passo estão no mesmo volume dos pés plásticos.

Los tornillos de este paso están en el mismo volumen que los pies plásticos.

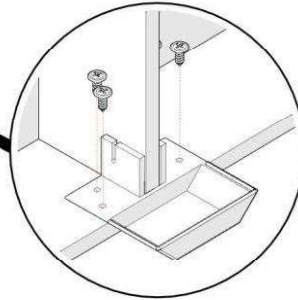

The screws for this step are in the same volume as the plastic feet.

PASSO / PASO / STEP 18

Cód.	Qtde.
000226	4

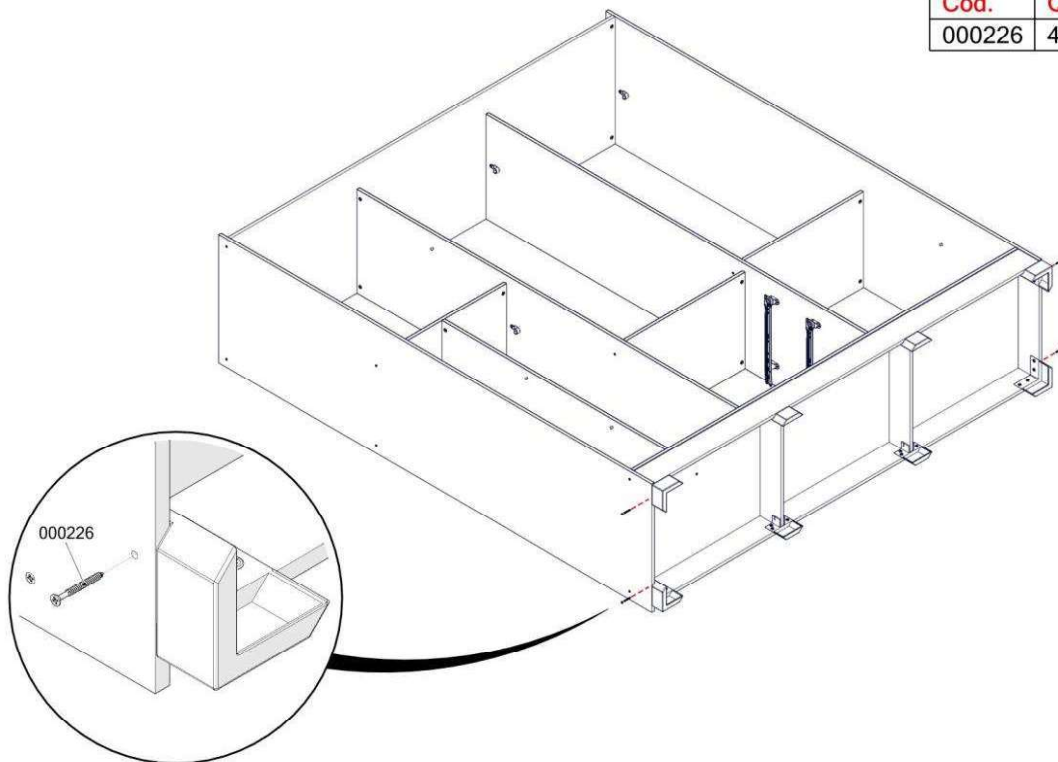

ARM006

PASSO / PASO / STEP 19

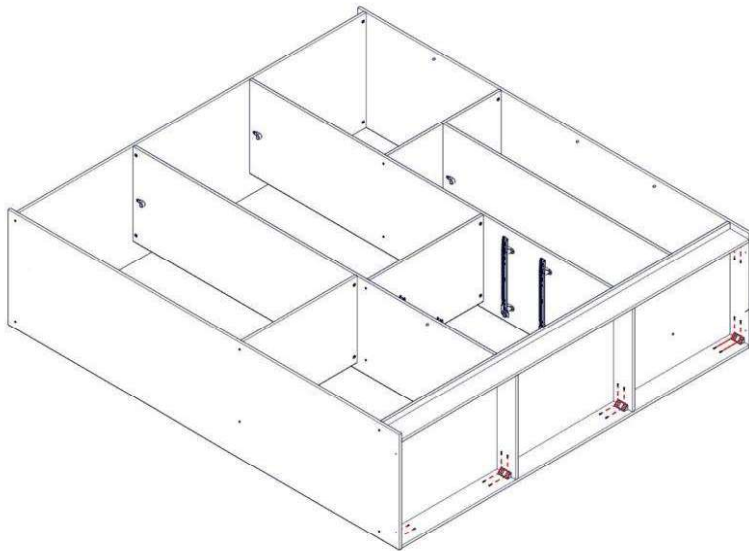

Cód.	Qtde.
000899	8
030457	32

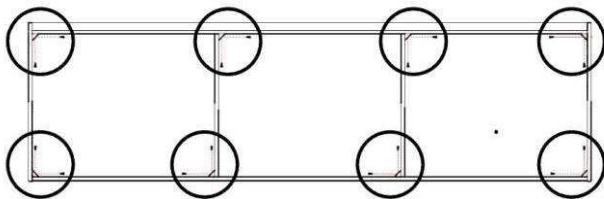
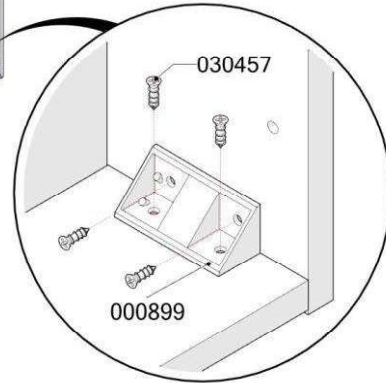

PASSO / PASO / STEP 20

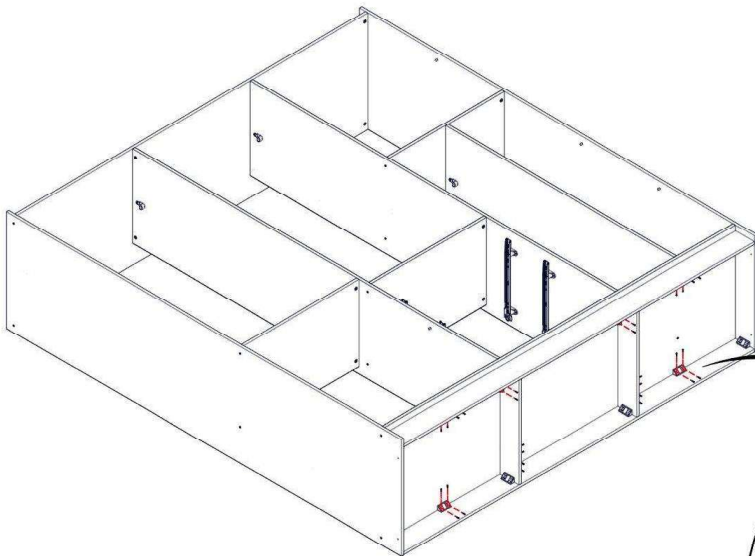

Cód.	Qtde.
000899	8
030457	32

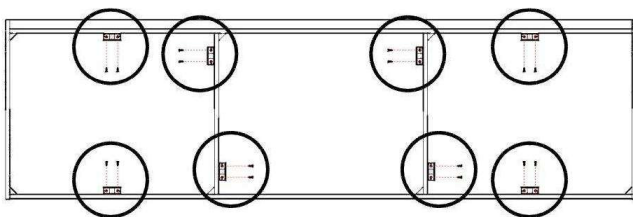
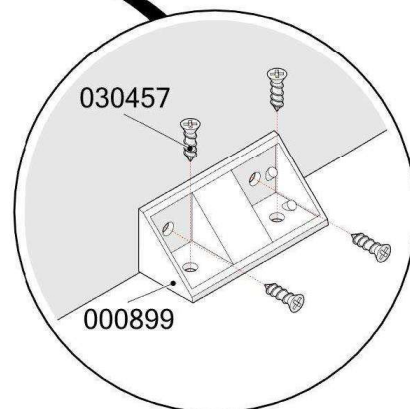

ARM006

PASSO / PASO / STEP 21

Cód.	Qtde.
000108	8
001901	8

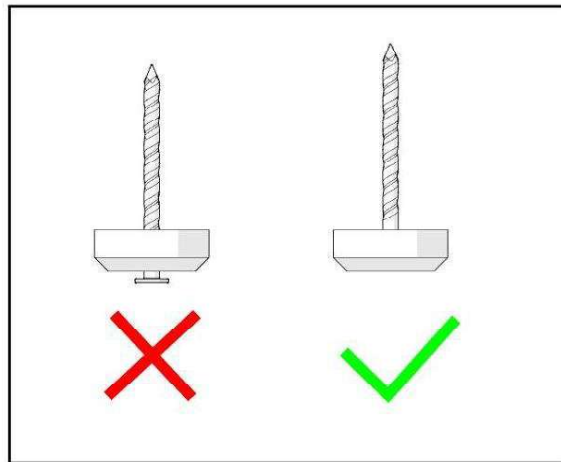
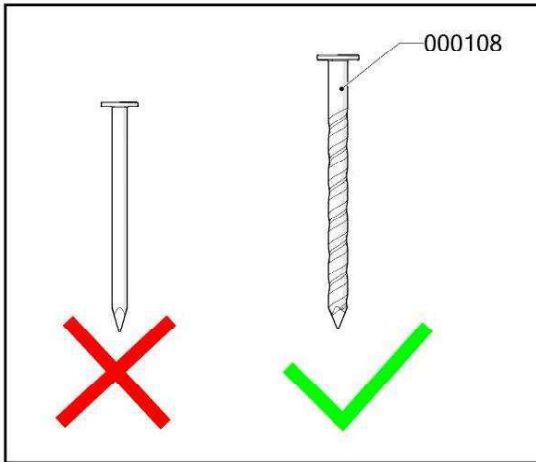
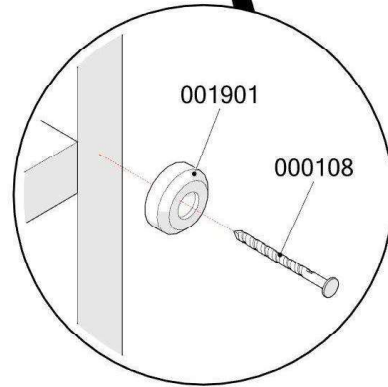
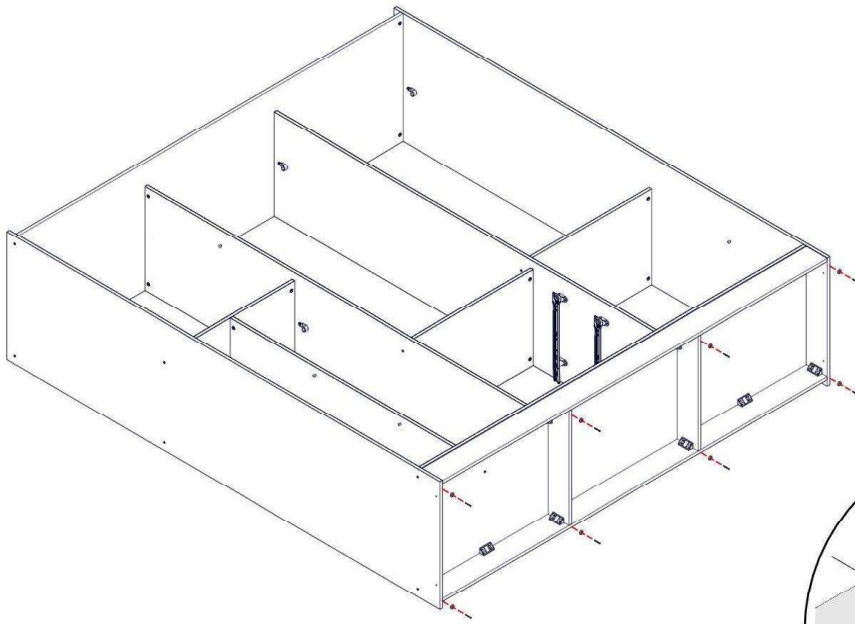

ATENÇÃO / ATENCIÓN / ATTENTION

Para a instalação das **COSTAS**, consulte o manual enviado junto com o volume em que as mesmas se encontram.

Para la instalación de las **ESPALDAS**, consulte el manual enviado junto con el volumen en el que se encuentran.

For the installation of the **BACKS**, refer to the manual sent along with the volume in which they are located.

PASSO / PASO / STEP 22

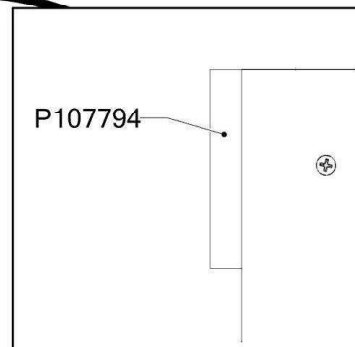
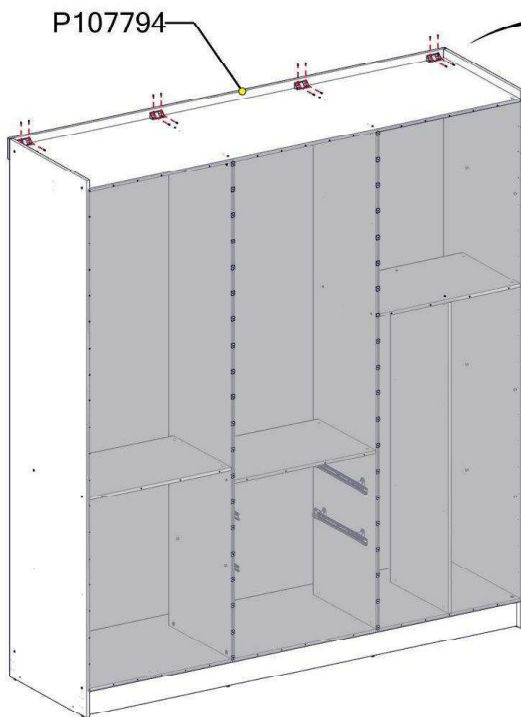

Cód.	Qtde.
000899	4
030457	16

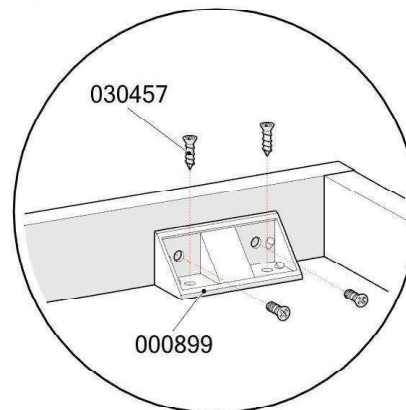

PASSO / PASO / STEP 23

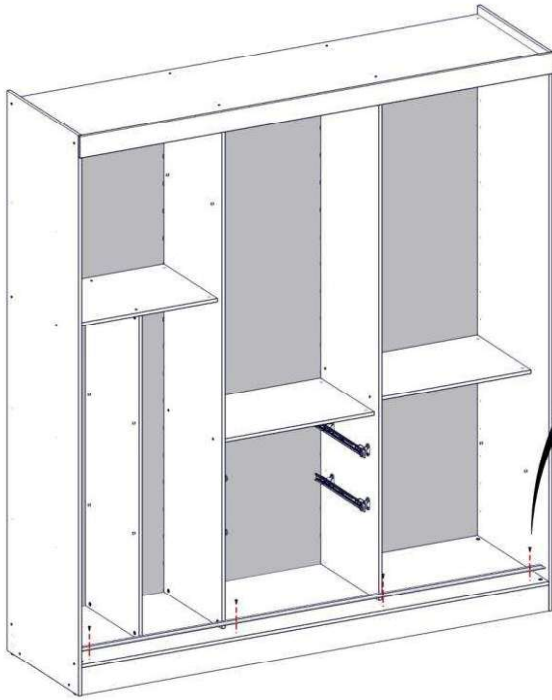

Cód.	Qtde.
056243	4
089862	1

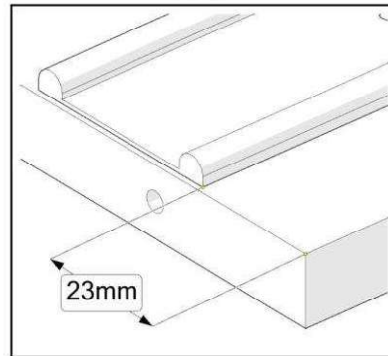
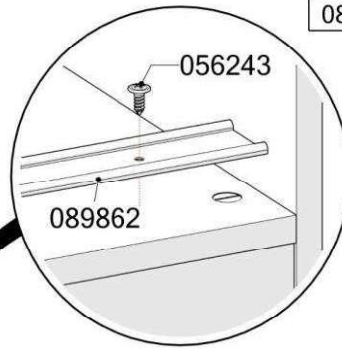

PASSO / PASO / STEP 24

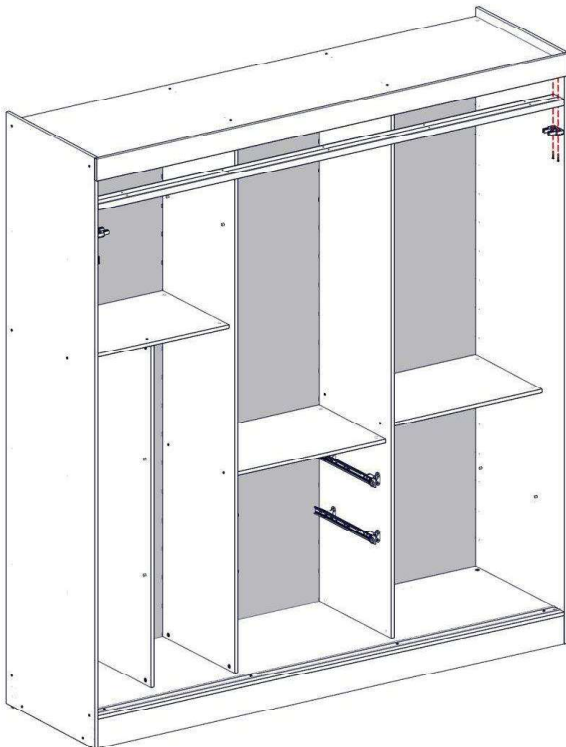

Cód.	Qtde.
054117	4
076031	4
089860	1

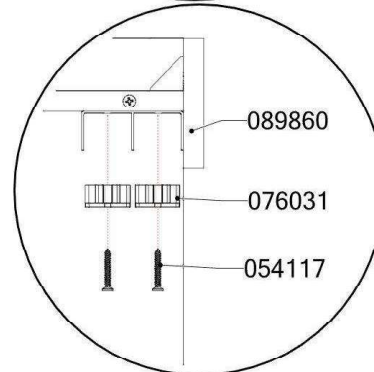
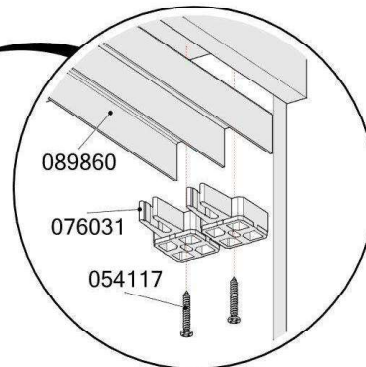

ARM006

PASSO / PASO / STEP 25

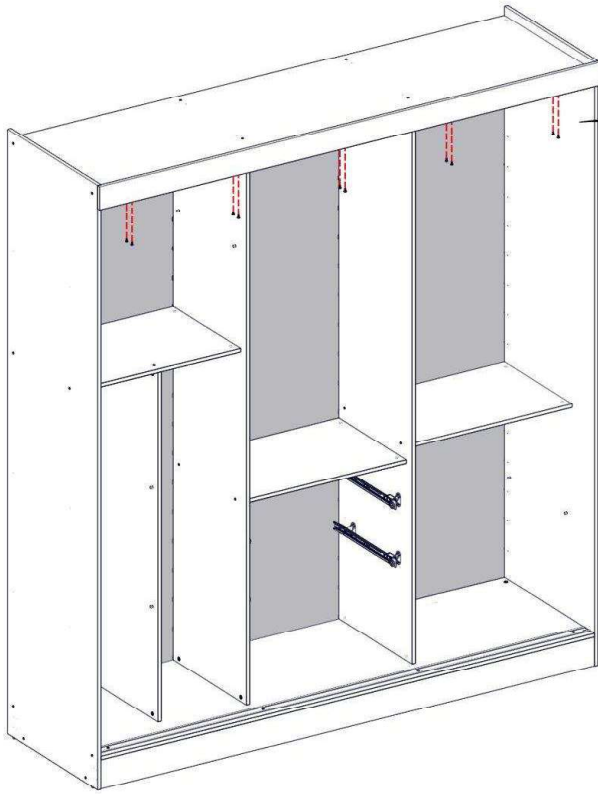

Cód.	Qtde.
056243	10

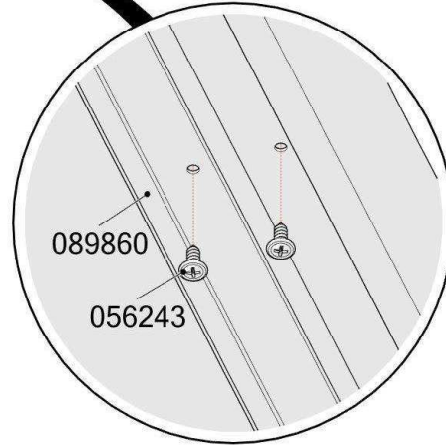

PASSO / PASO / STEP 26

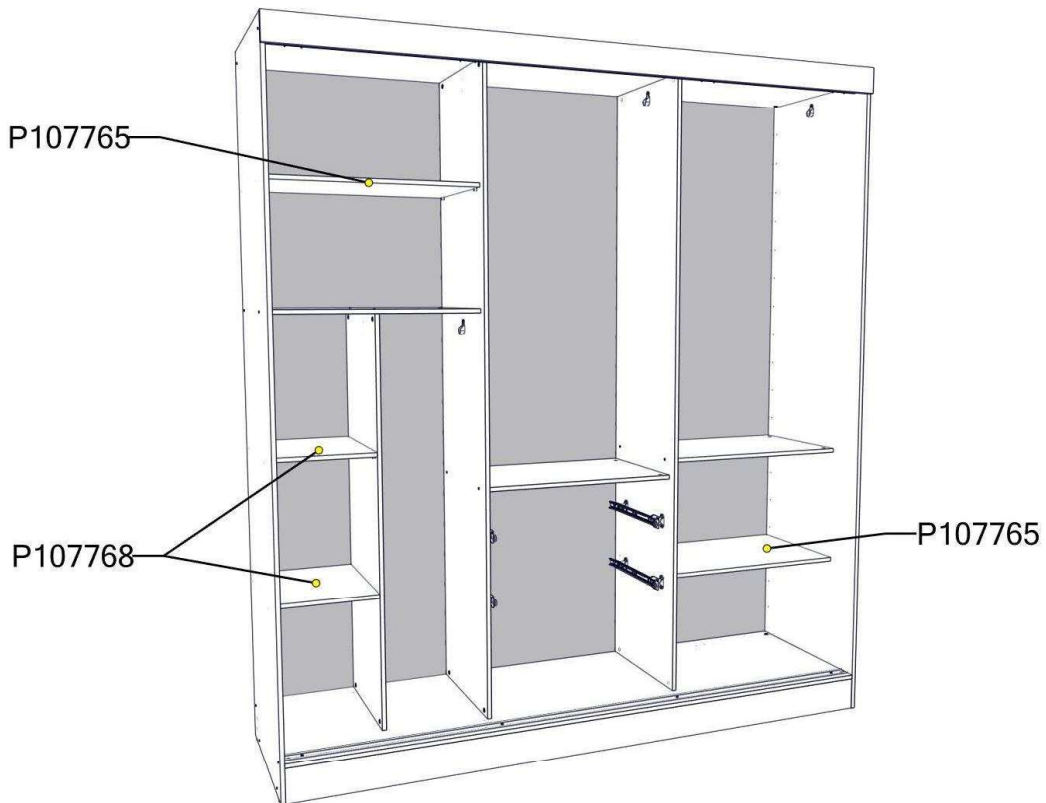

ARM006

PASSO / PASO / STEP 27

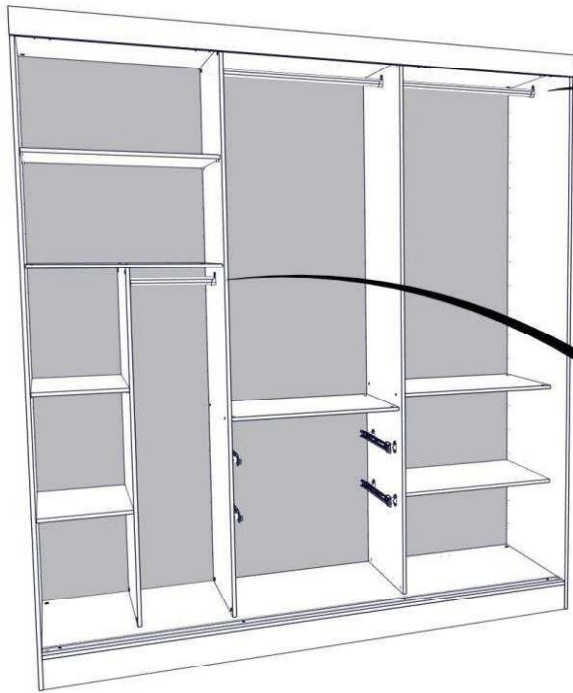

Cód.	Qtde.
084115	2
089859	1

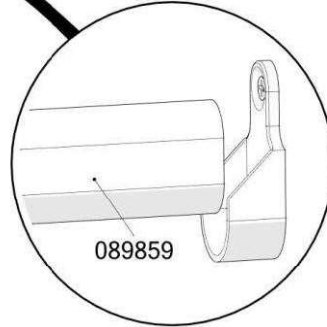
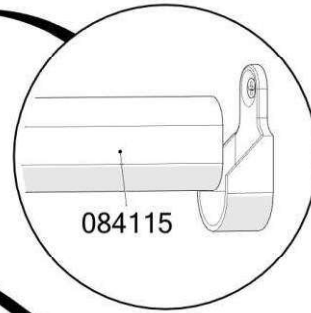

PASSO / PASO / STEP 28

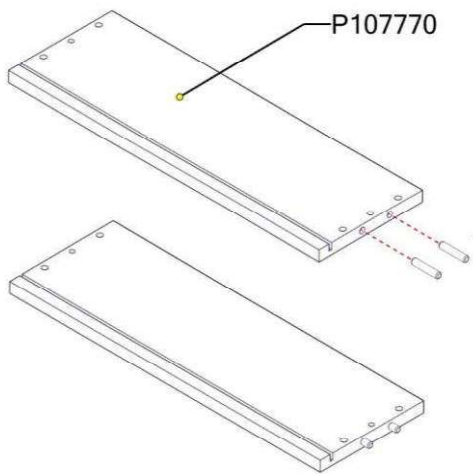

Cód.	Qtde.
001802	4
000041	1

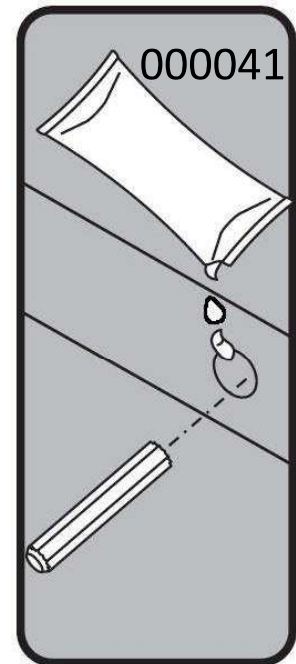
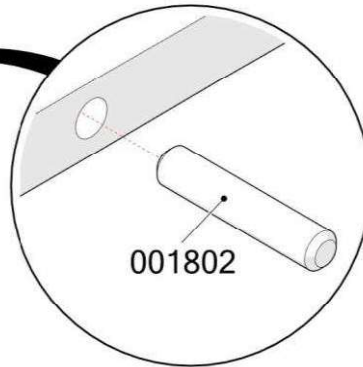

ARM006

PASSO / PASO / STEP 29

Cód.	Qtde.
001802	4
000041	1

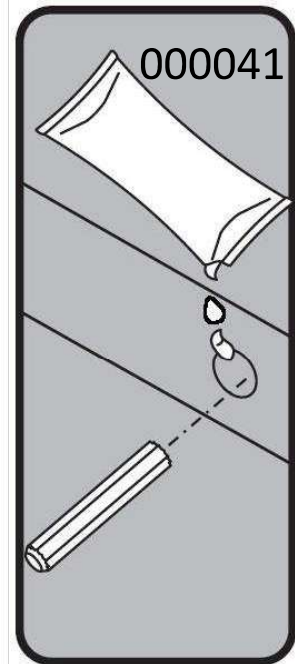
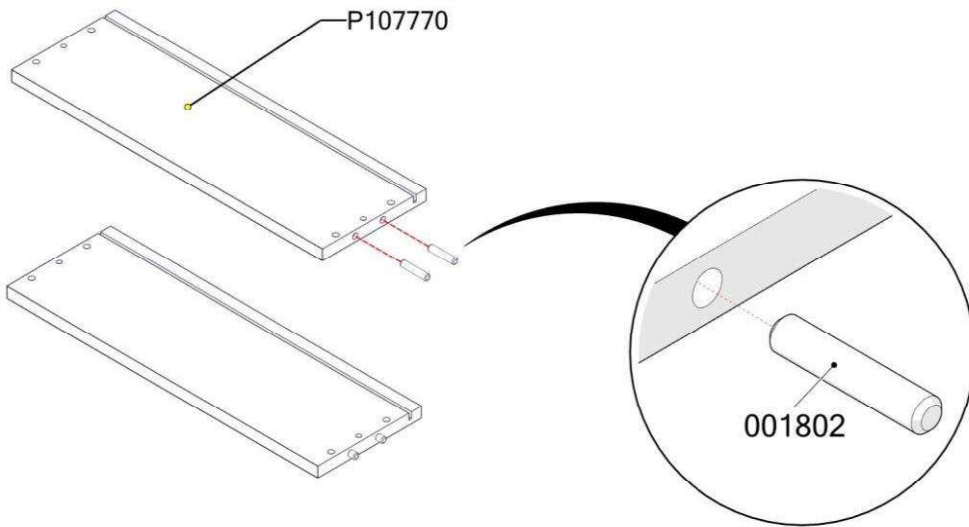

PASSO / PASO / STEP 30

Cód.	Qtde.
001802	8
000041	1

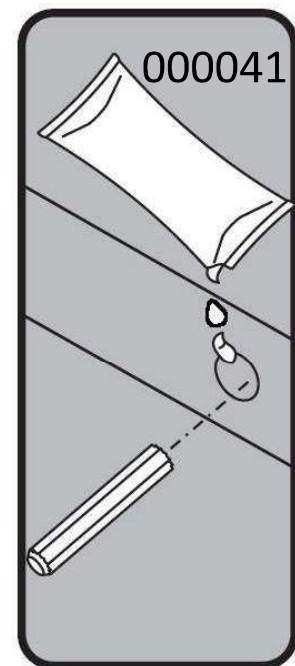
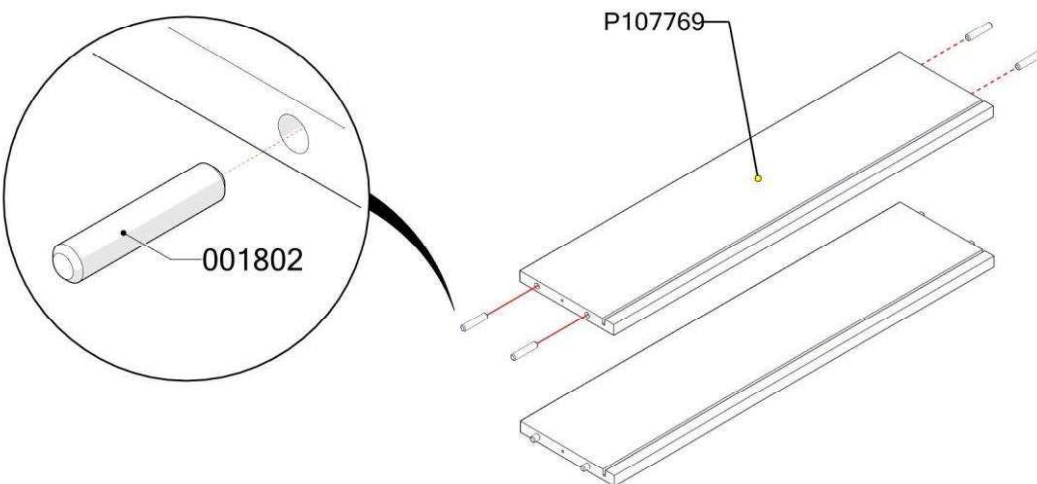

PASSO / PASO / STEP 31

Cód.	Qtde.
000226	4

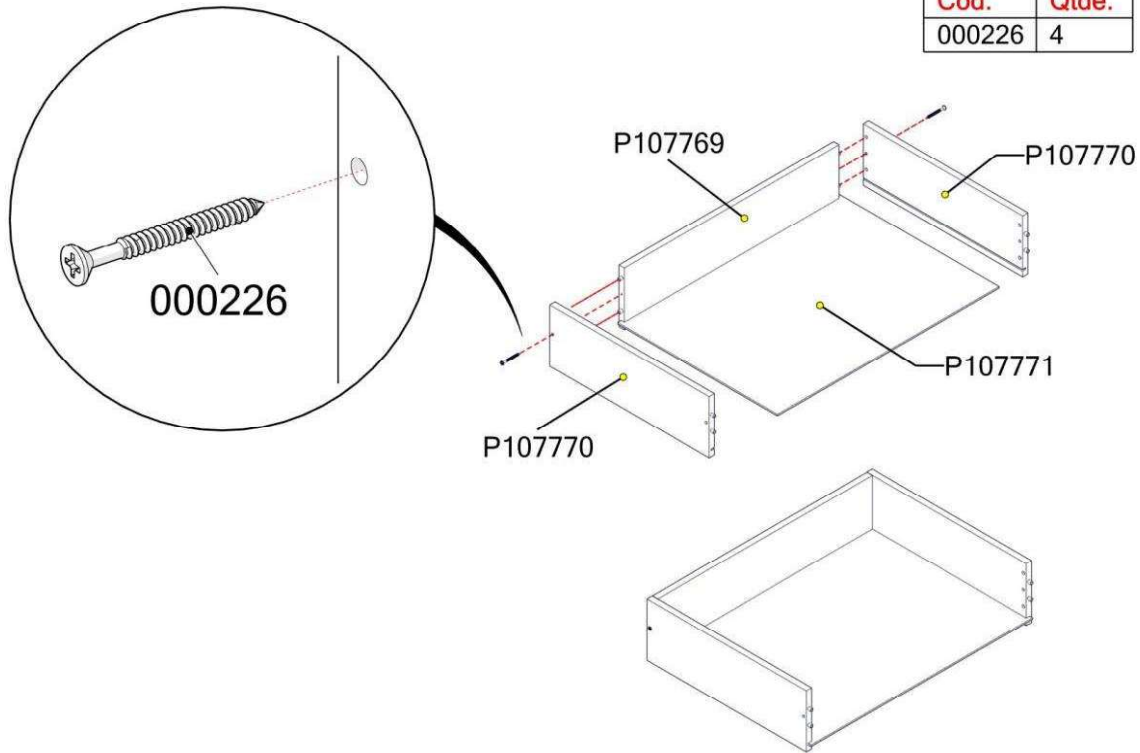

PASSO / PASO / STEP 32

Cód.	Qtde.
000899	4
030457	16

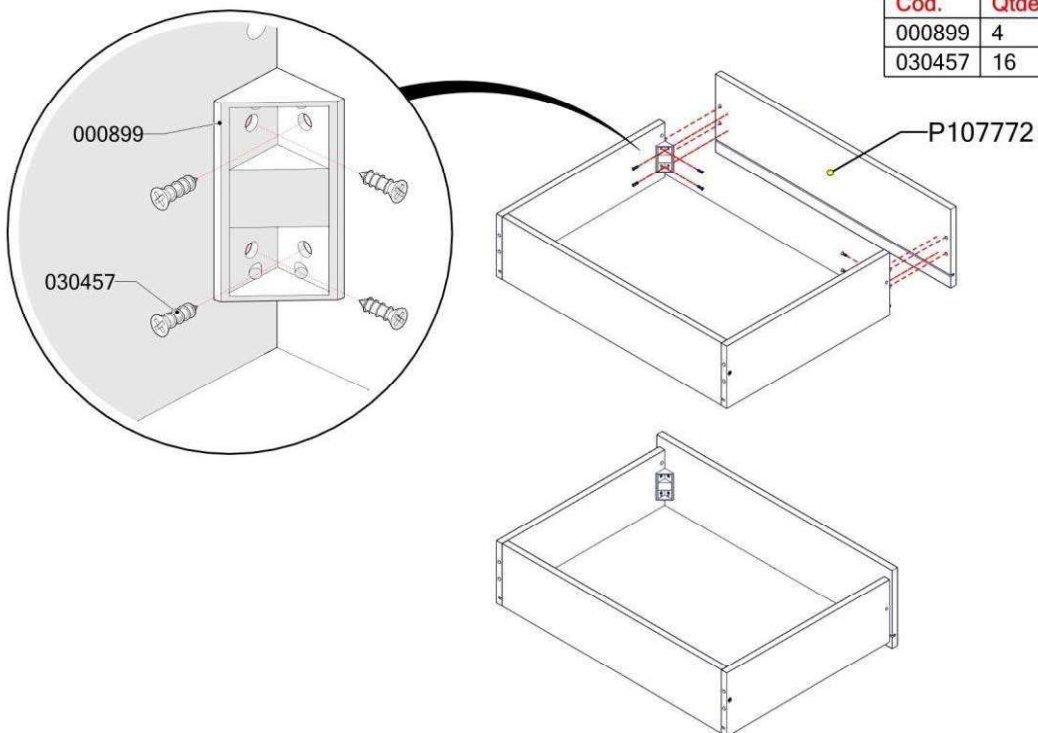

PASSO / PASO / STEP 33

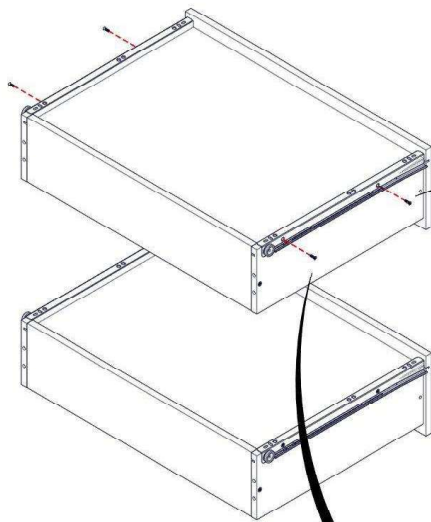

Cód.	Qtde.
030457	8
CRM350	4

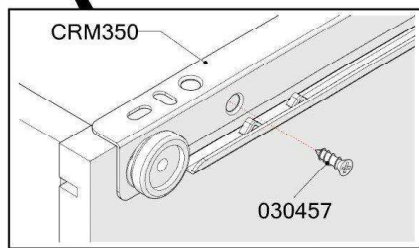
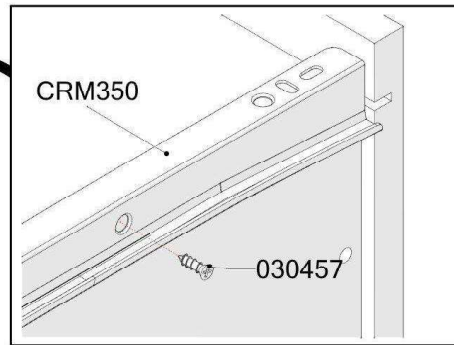

PASSO / PASO / STEP 34

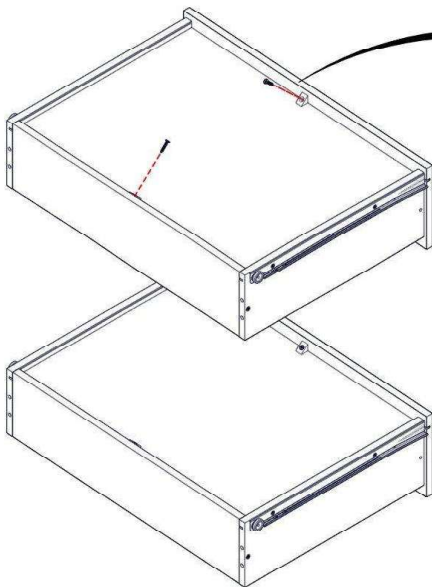

Cód.	Qtde.
005256	4
018458	4

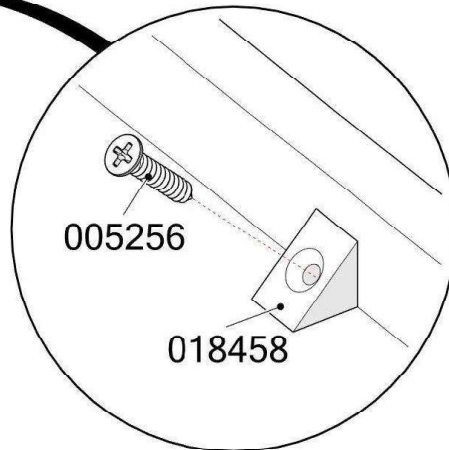

PASSO / PASO / STEP 35

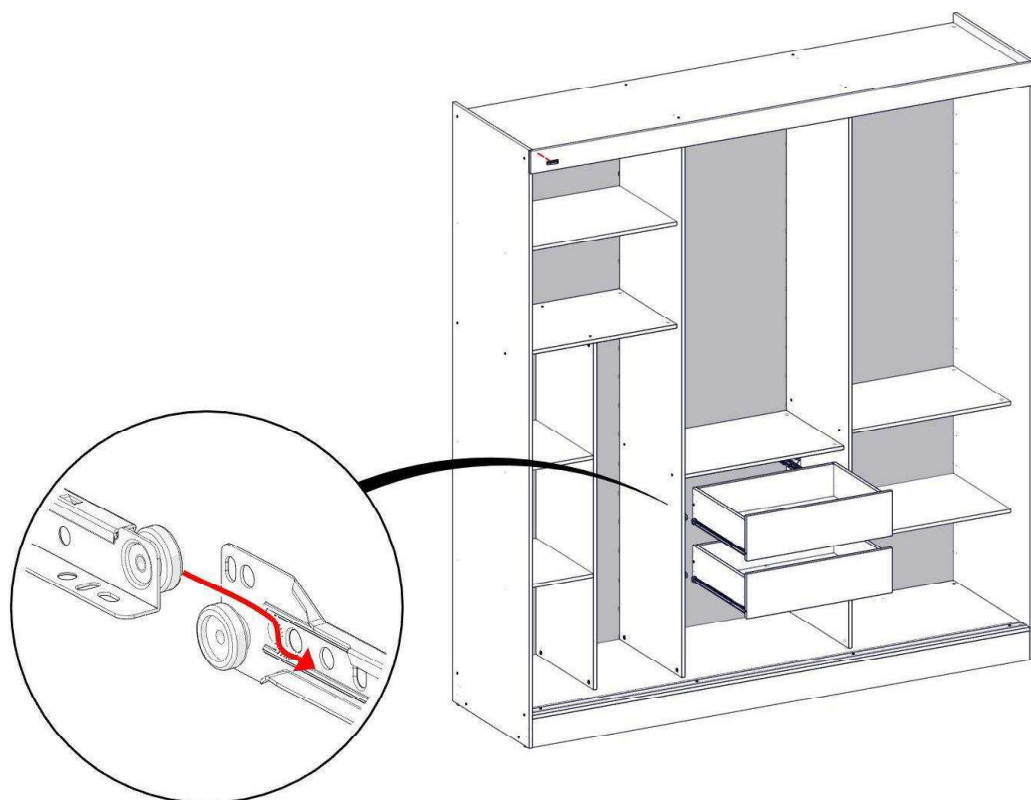

PASSO / PASO / STEP 36

Cód.	Qtde.
075900	1

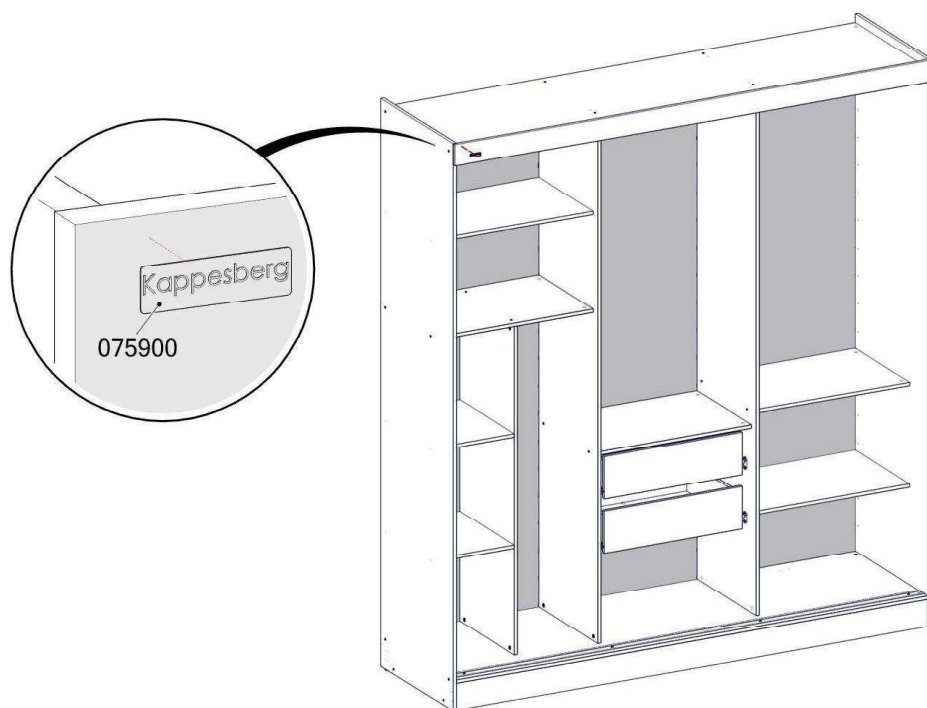

ARM006

ATENÇÃO / ATENCIÓN / ATTENTION

Para a instalação das **PORTAS**, consulte o manual enviado junto com o volume em que as mesmas se encontram.

Para la instalación de las **PUERTAS**, consulte el manual enviado junto con el volumen en el que se encuentran.

For the installation of the **DOORS**, refer to the manual sent along with the volume in which they are located.

PASSO / PASO / STEP 37

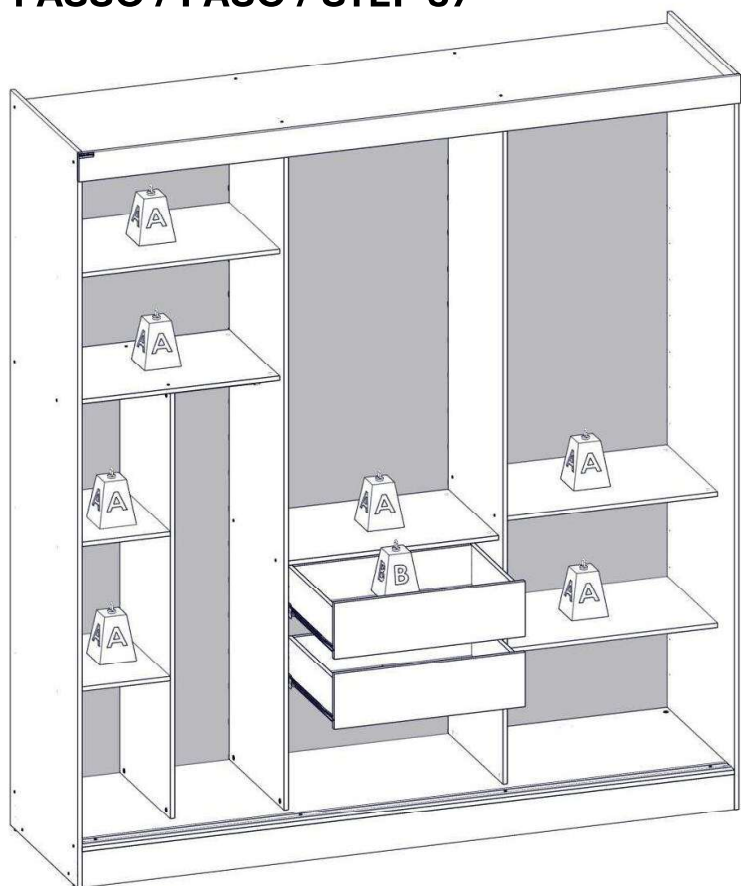

Carga Suportável / Peso soportado / Weight supported

Peso máximo de carga ilustrado no desenho ao lado distribuídos de maneira uniforme.

Peso máximo de carga ilustrado en el dibujo distribuidos de manera uniforme

Maximum load weight illustrated in the drawing distributed from uniform way.

	KG	LB
A	7	15,43
B	6	13,23

Limpeza / Limpieza / Cleaning:

- Retire o pó com uma flanela seca.
- Use um pano macio levemente umedecido com água para limpar.
- Se necessário, utilize detergente ou sabão neutro diluído em água.
- Não use produtos abrasivos para evitar danos ao móvel.

- Retire el polvo con un paño seco.
- Use un paño suave ligeramente humedecido con agua para limpiar.
- Si es necesario, utilice detergente o jabón neutro diluido en agua.
- No use productos abrasivos para evitar dañar el mueble.

- Dust with a dry cloth.
- Use a soft cloth slightly dampened with water for cleaning.
- If necessary, use detergent or neutral soap diluted in water.
- Do not use abrasive products to avoid damaging the furniture.

Conservação / Conservación / Maintenance:

- Proteja o móvel contra umidade excessiva.
- Evite exposição direta ao Sol ou fontes de calor.
- Não exceda o peso máximo indicado para prateleiras e gavetas.
- Aperte os parafusos periodicamente para manter a estabilidade.
- Para mover o móvel, levante-o em vez de arrastá-lo.
- Móveis pesados devem ser transportados por duas pessoas.

- Proteja el mueble de la humedad excesiva.
- Evite la exposición directa al sol o fuentes de calor.
- No exceda el peso máximo indicado para estantes y cajones.
- Apriete los tornillos periódicamente para mantener la estabilidad.
- Para mover el mueble, levántelo en lugar de arrastrarlo.
- Los muebles pesados deben ser transportados por dos personas.

- Protect the furniture from excessive moisture.
- Avoid direct exposure to the Sun or heat sources.
- Do not exceed the maximum weight indicated for shelves and drawers.
- Tighten the screws periodically to maintain stability.
- To move the furniture, lift it instead of dragging it.
- Heavy furniture should be moved by two people.

Garantia / Garantía / Warranty:

Garantia de 90 dias para defeitos de fabricação.
A garantia será anulada em caso de montagem incorreta ou uso inadequado.

Garantía de 90 días por defectos de fabricación.
La garantía se anulará en caso de montaje incorrecto o uso indebido.

90-day warranty for manufacturing defects.
The warranty will be voided in case of incorrect assembly or improper use.

kappesberg

Manual de Montagem
Instrucciones de Montaje / Assembly Instructions

PC002

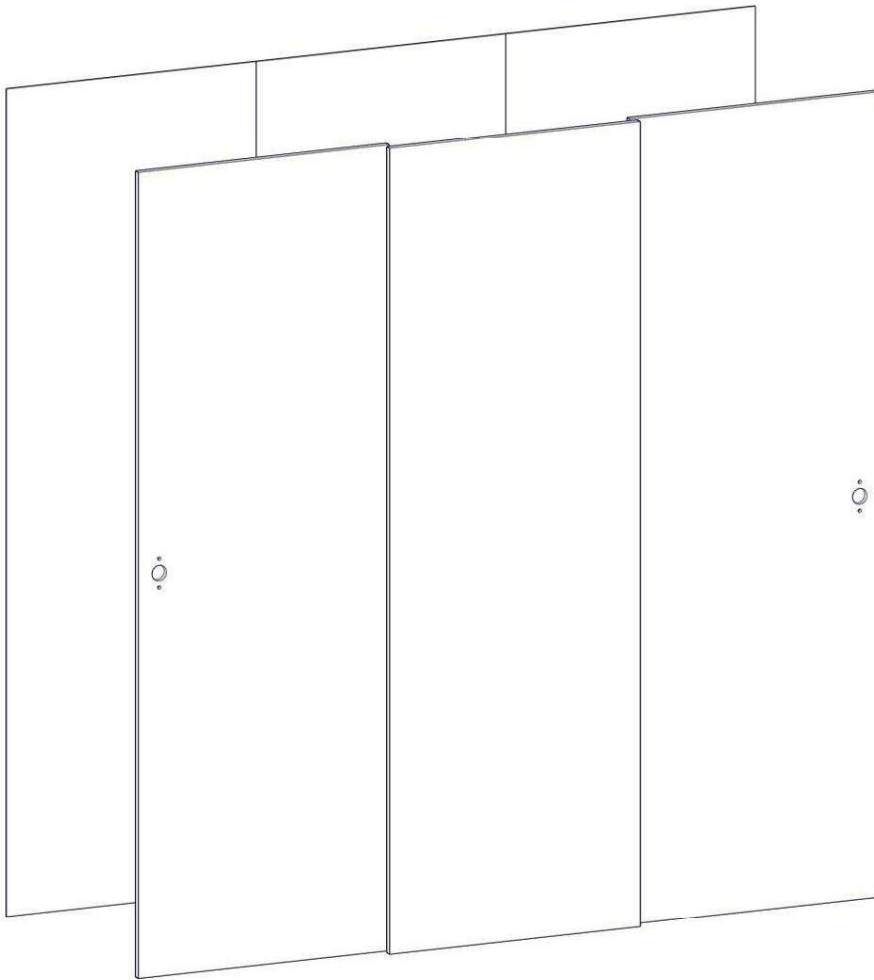

Imagens meramente ilustrativas
Imágenes ilustrativas/Images merely illustrative.

INSTRUÇÕES PARA A MONTAGEM
INSTRUCCIONES DE MONTAJE
ASSEMBLY INSTRUCTIONS

Para realizar a montagem são necessárias **2 pessoas**.

Para realizar el montaje, se necesitan **2 personas**.

To assemble it, **2 people** are required.

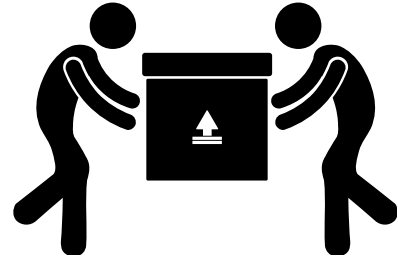

Ferramentas necessárias realizar a montagem.
Ferramentas **NÃO** fornecidas.

Herramientas necesarias para el montaje.
Herramientas **NO** proporcionadas.

Tools required for assembly.
Tools **NOT** provided.

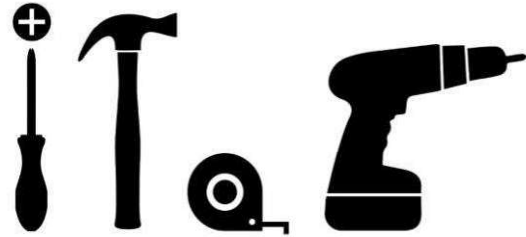

PERIGO DE ASFIXIA - Este produto contém peças pequenas, mantenha fora do alcance das crianças.

PELIGRO DE ASFIXIA - Este producto contiene piezas pequeñas. Mantener fuera del alcance de los niños.

CHOKING HAZARD - This product contains small parts. Keep out of reach of children.



Em caso de dúvida, entre em contato com nosso atendimento:

En caso de duda, comuníquese con nuestro servicio de atención al cliente:

If in doubt, contact our customer service:

+55 51 2500 7800

www.kappesberg.com.br



INSTRUÇÕES PARA A MONTAGEM
INSTRUCCIONES DE MONTAJE
ASSEMBLY INSTRUCTIONS

Siga atentamente os passos de montagem indicados no manual.

Siga atentamente los pasos de montaje indicados en el manual.

Follow the assembly steps carefully as indicated in the manual.



Antes de começar a montagem, identifique e separe todas as peças e acessórios.

Antes de comenzar el montaje, identifique y separe todas las piezas y accesorios.

Before starting the assembly, identify and separate all the parts and accessories.



Durante a montagem, mantenha peças e acessórios organizados para evitar acidentes.

Durante el montaje, mantenga las piezas y accesorios organizados para evitar accidentes.

During assembly, keep parts and accessories organized to avoid accidents.



Para proteger seu móvel, faça a montagem sobre uma superfície limpa e plana.

Dica: Você pode utilizar a embalagem do produto para forrar o espaço onde será feita a montagem.

Para proteger su mueble, realice el montaje sobre una superficie limpia y plana.

Consejo: Puede utilizar el embalaje del producto para forrar el área donde se realizará el montaje.

To protect your furniture, assemble it on a clean and flat surface.

Tip: You can use the product packaging to line the area where the assembly will be done.



PEÇAS - PIEZAS - PARTS

QTD.	CÓDIGO / CODE	DESCRIÇÃO	DESCRIPCIÓN	DESCRIPTION	C x L x E	L x W x T
3	P107764	COSTA	COSTA	COAST	1867 x 597 x 3 mm	73.50 x 23.50 x 0.12 in
1	P107785	PORTA	PUERTA	DOOR	1817 x 600 x 15 mm	71.54 x 23.62 x 0.59 in
2	P107786	PORTA	PUERTA	DOOR	1817 x 600 x 15 mm	71.54 x 23.62 x 0.59 in

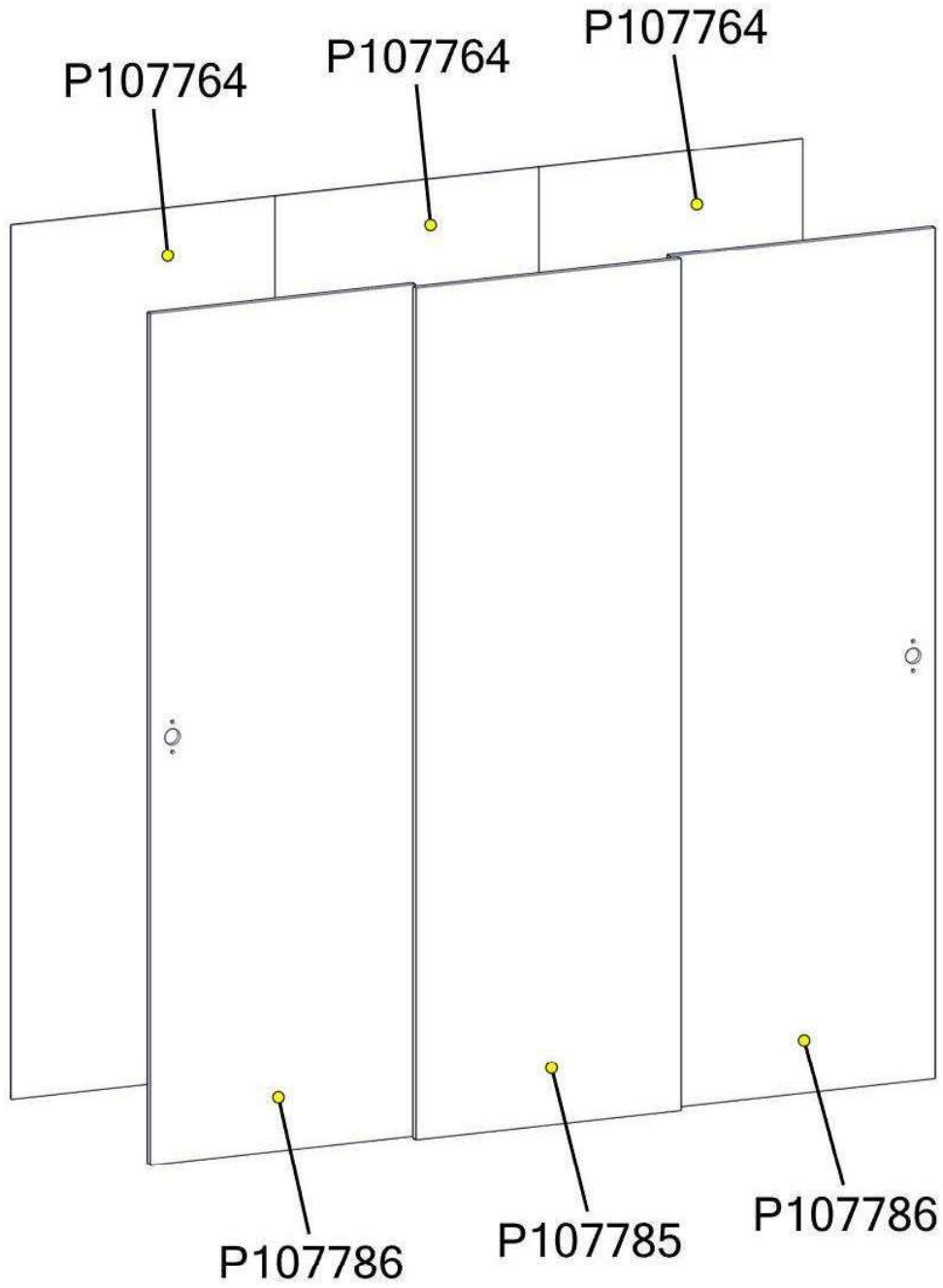

ATENÇÃO / ATENCIÓN / ATTENTION

Os acessórios para a fixação das costas e das portas encontram-se com os demais acessórios no volume do corpo do roupeiro.

Los accesorios para la fijación de las partes traseras y las puertas se encuentran con los demás accesorios en el volumen del cuerpo del armario.

The accessories for fixing the back panels and doors are located with the other accessories in the wardrobe's body volume.

PASSO / PASO / STEP 1

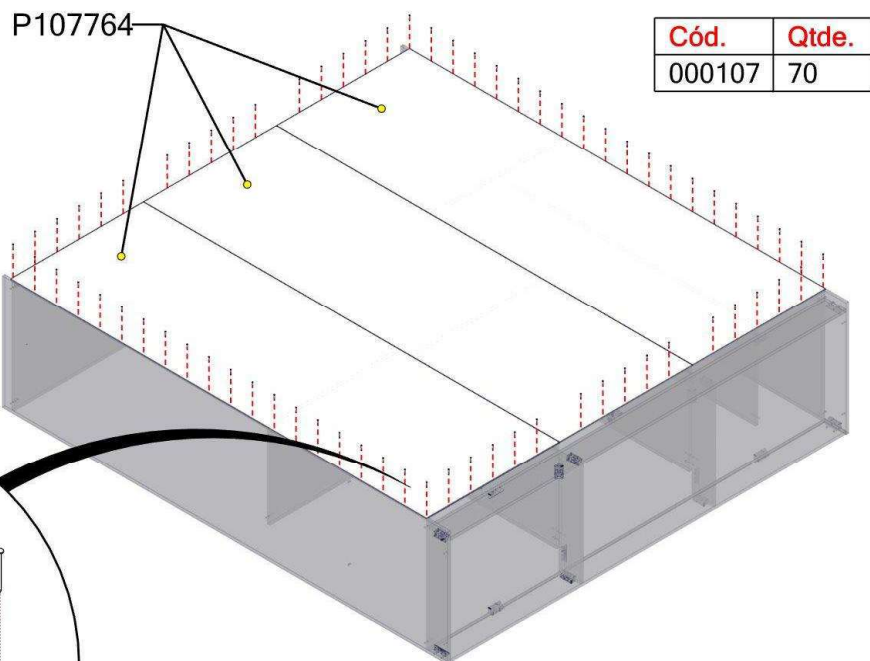

PC002

5

PASSO / PASO / STEP 2

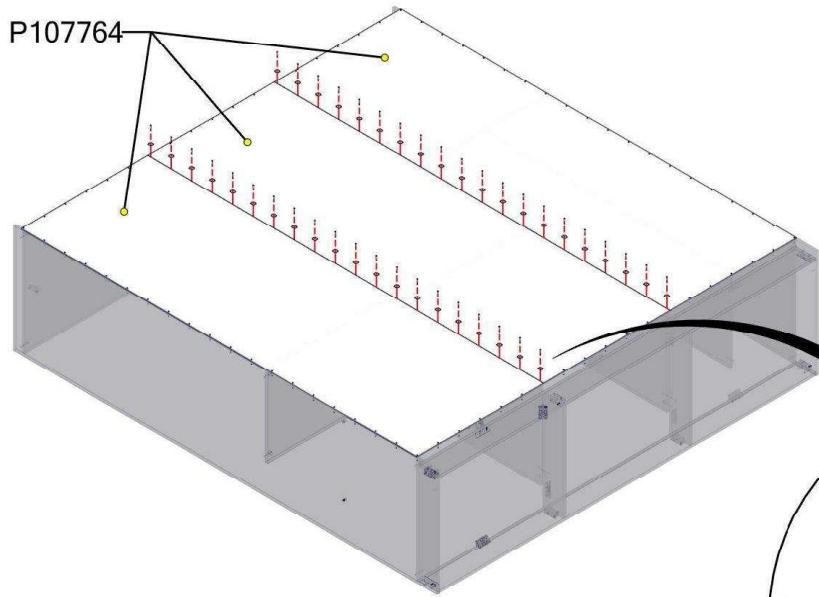

Cód.	Qtde.
000107	40
001423	40

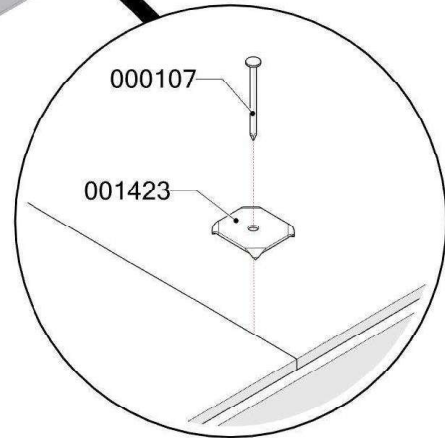

PASSO / PASO / STEP 3

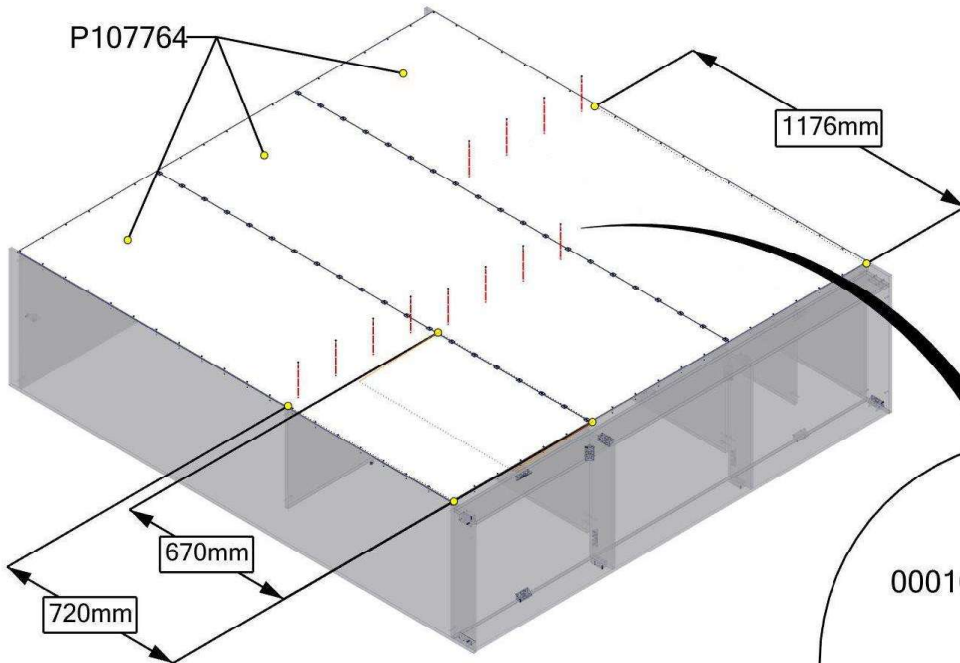

Cód.	Qtde.
000107	12

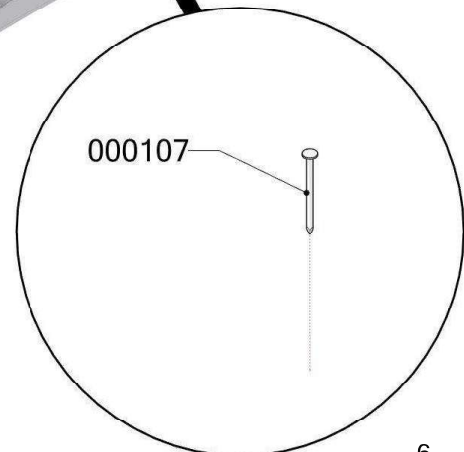

PC002

PASSO / PASO / STEP 4

Antes de fixar os carrinhos nas portas, certifique-se de que as roldanas estejam travadas. Caso não estejam, trave-as.

Antes de fijar los carritos a las puertas, asegúrese de que las poleas estén bloqueadas. Si no lo están, bloquéelas.

Before fixing the carts to the doors, make sure the pulleys are locked. If they are not, lock them.

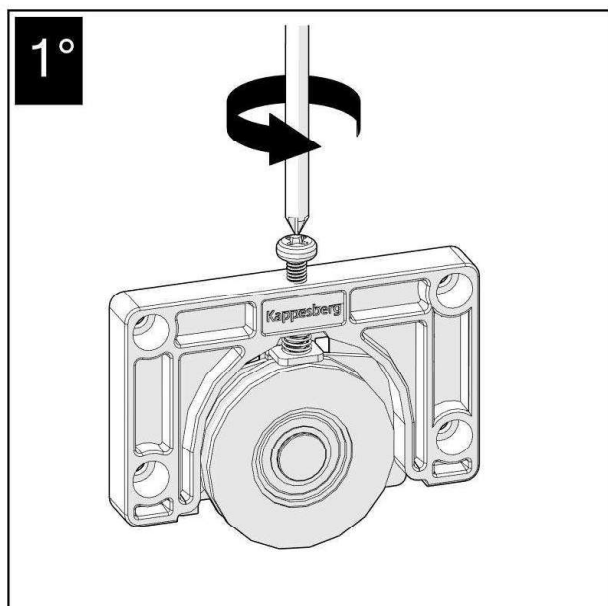

Gire o parafuso para cima.

Gire el tornillo hacia arriba.

Turn the screw upwards.

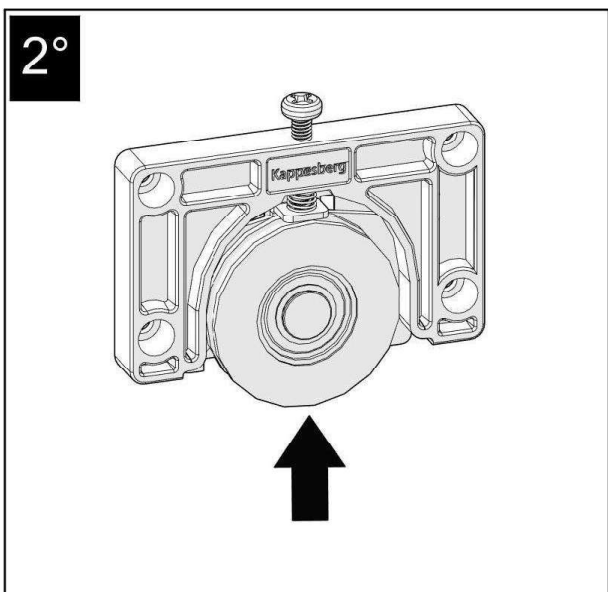

Pressione a roldana até travá-la.

Presione la polea hasta bloquearla.

Press the pulley until it locks.

PASSO / PASO / STEP 5 - A

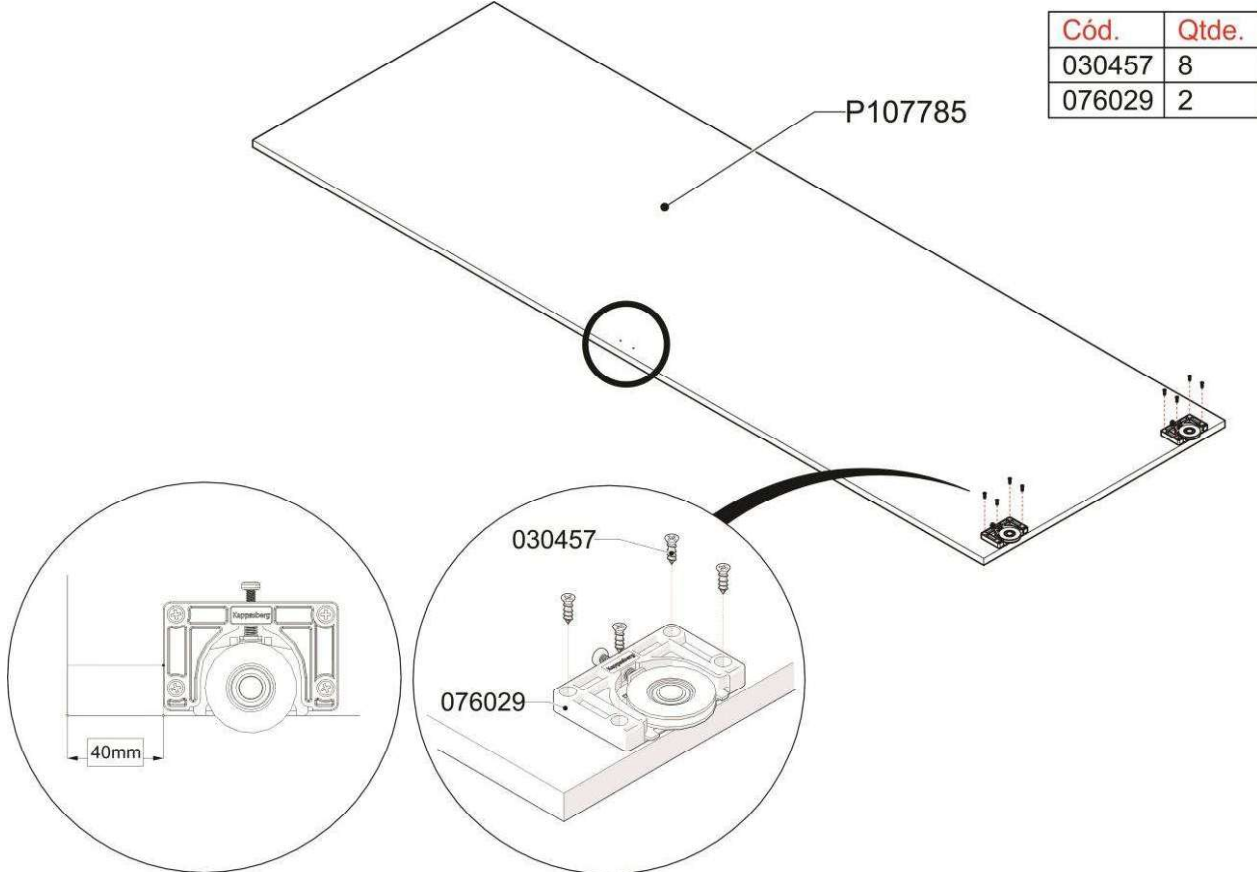

Cód.	Qtde.
030457	8
076029	2

PASSO / PASO / STEP 5 - B

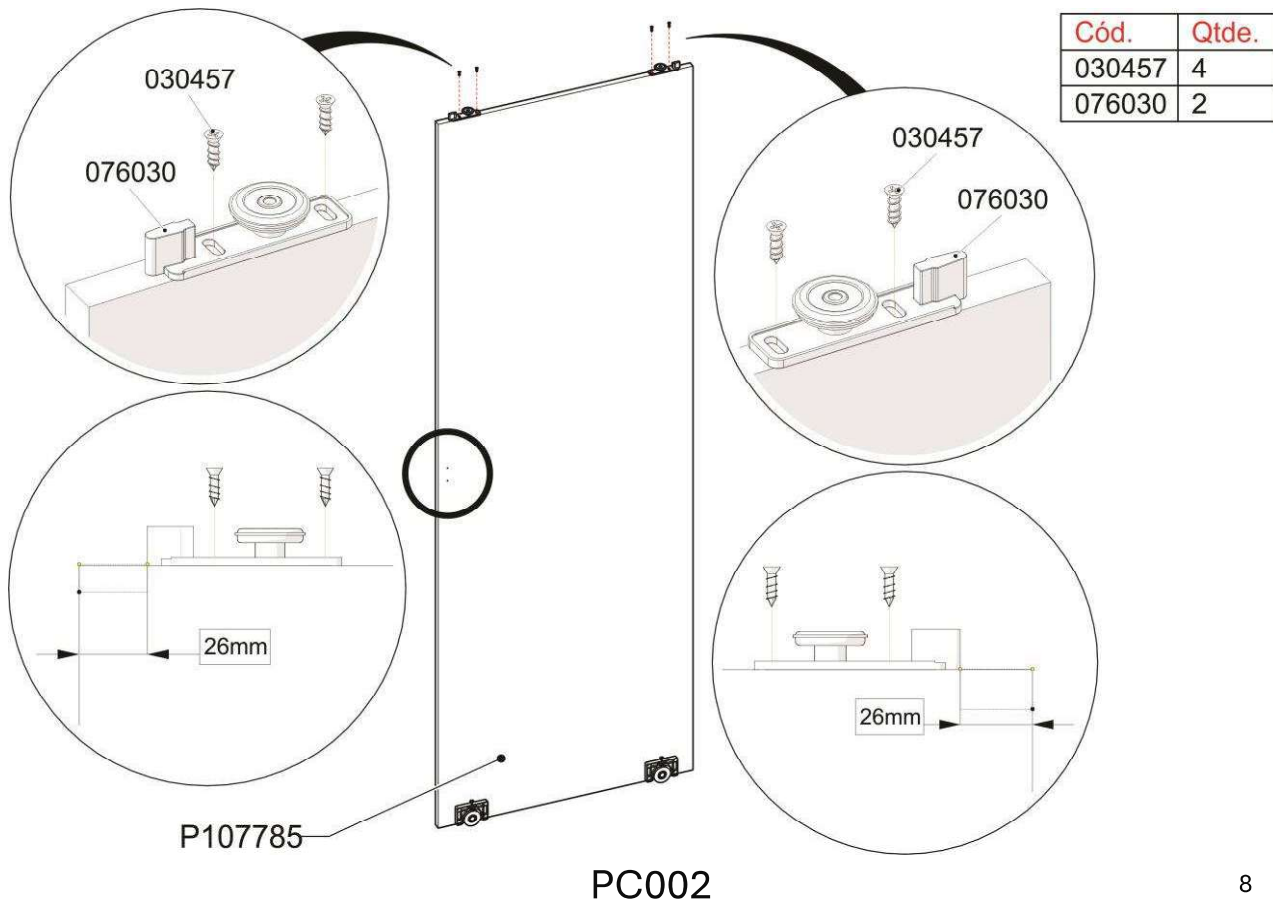

Cód.	Qtde.
030457	4
076030	2

PC002

PASSO / PASO / STEP 6 - A

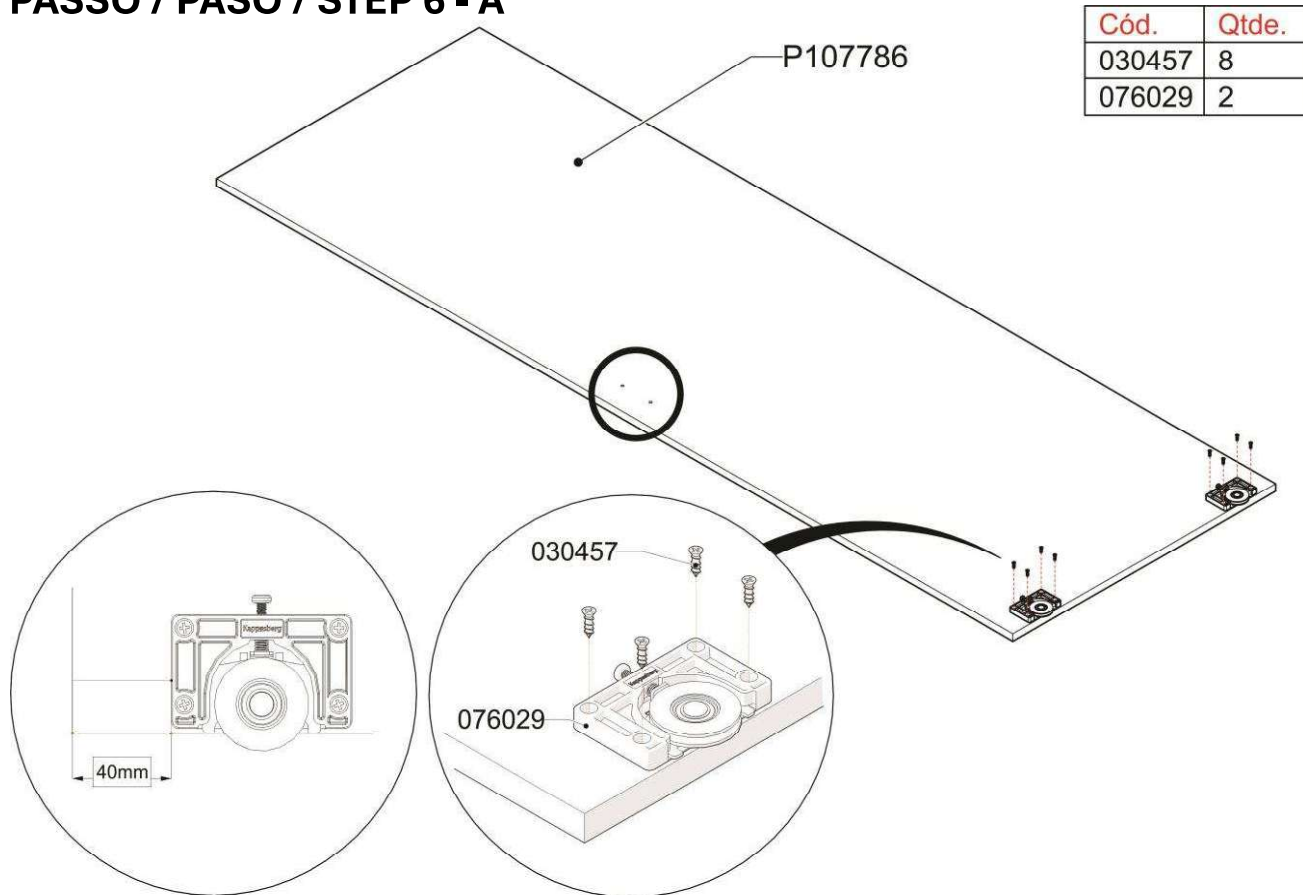

PASSO / PASO / STEP 6 - B

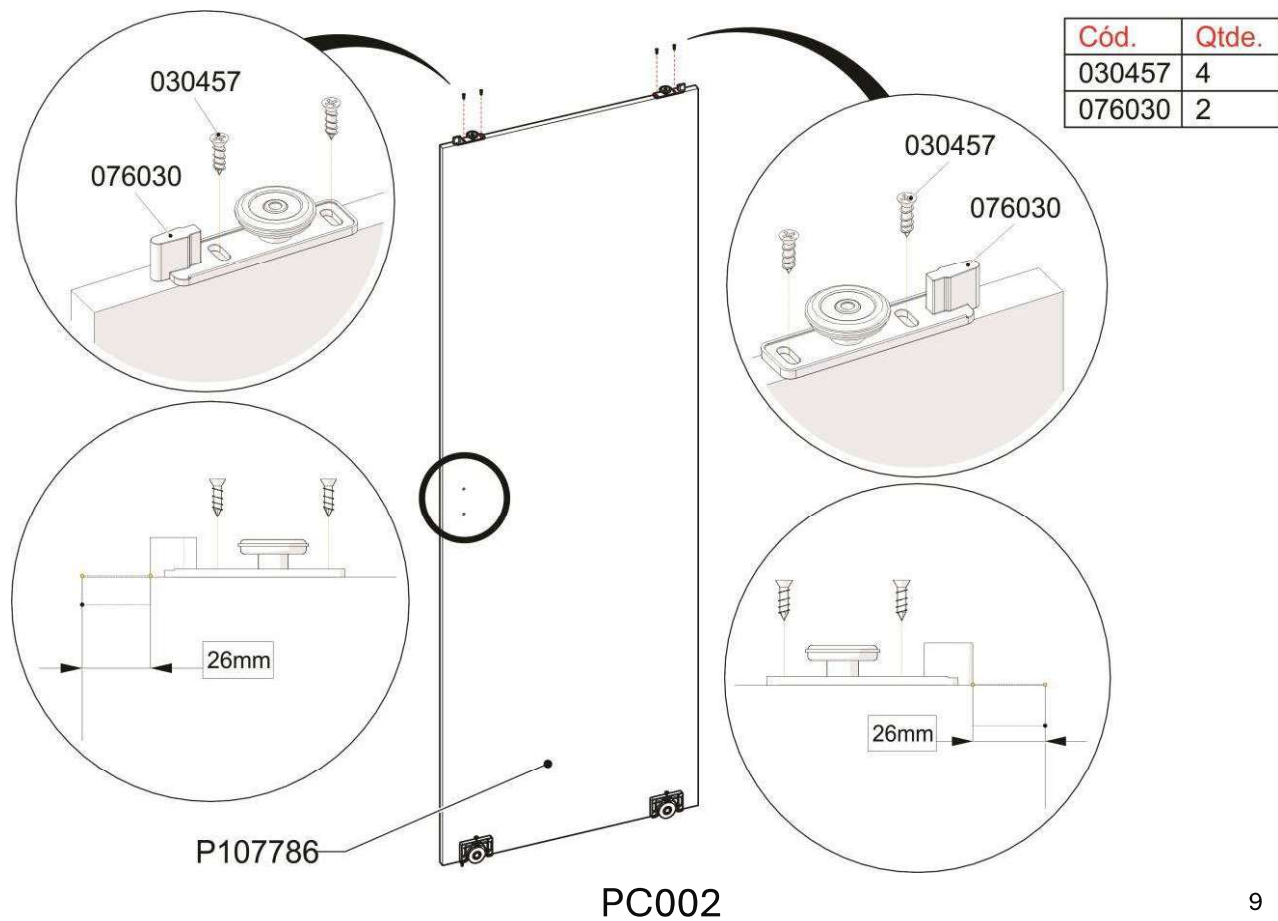

PASSO / PASO / STEP 7 - A

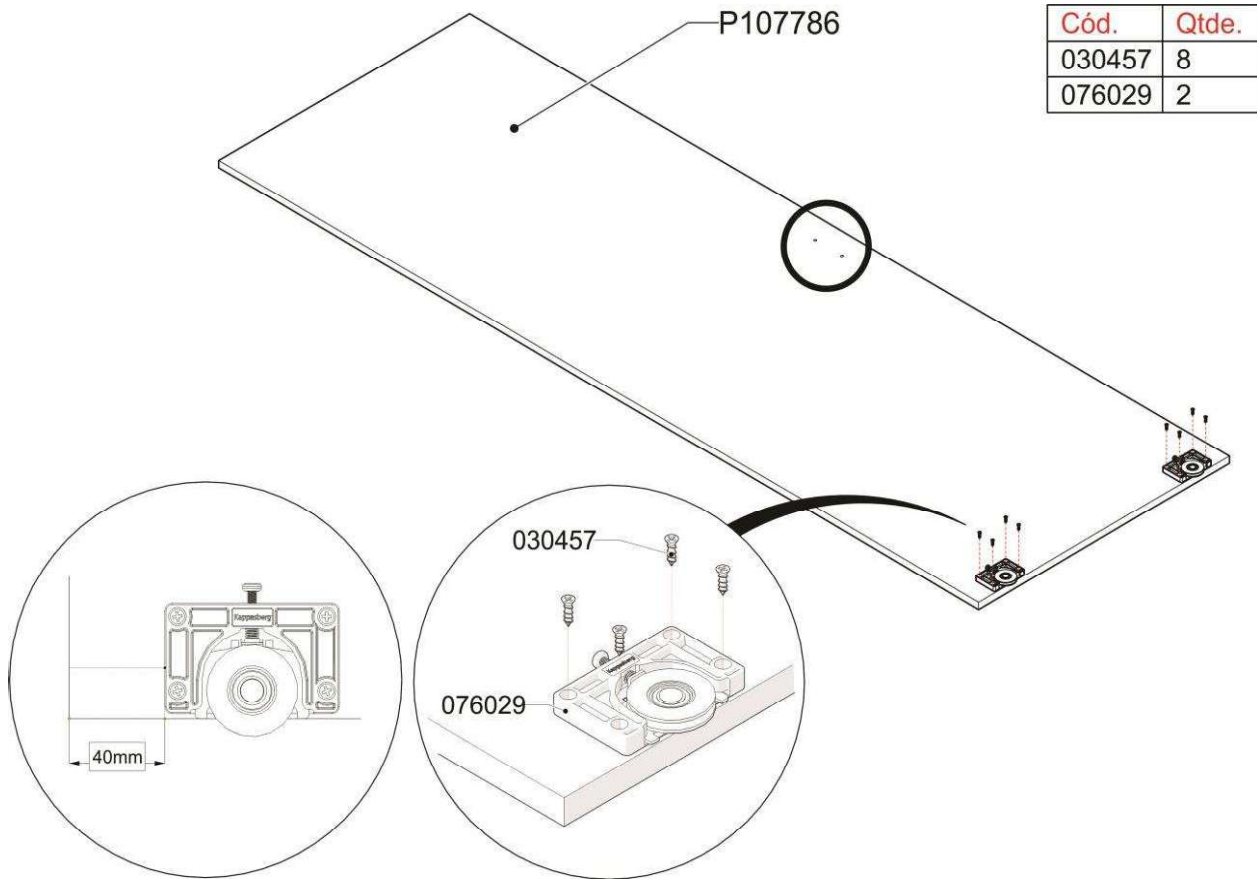

Cód.	Qtde.
030457	8
076029	2

PASSO / PASO / STEP 7 - B

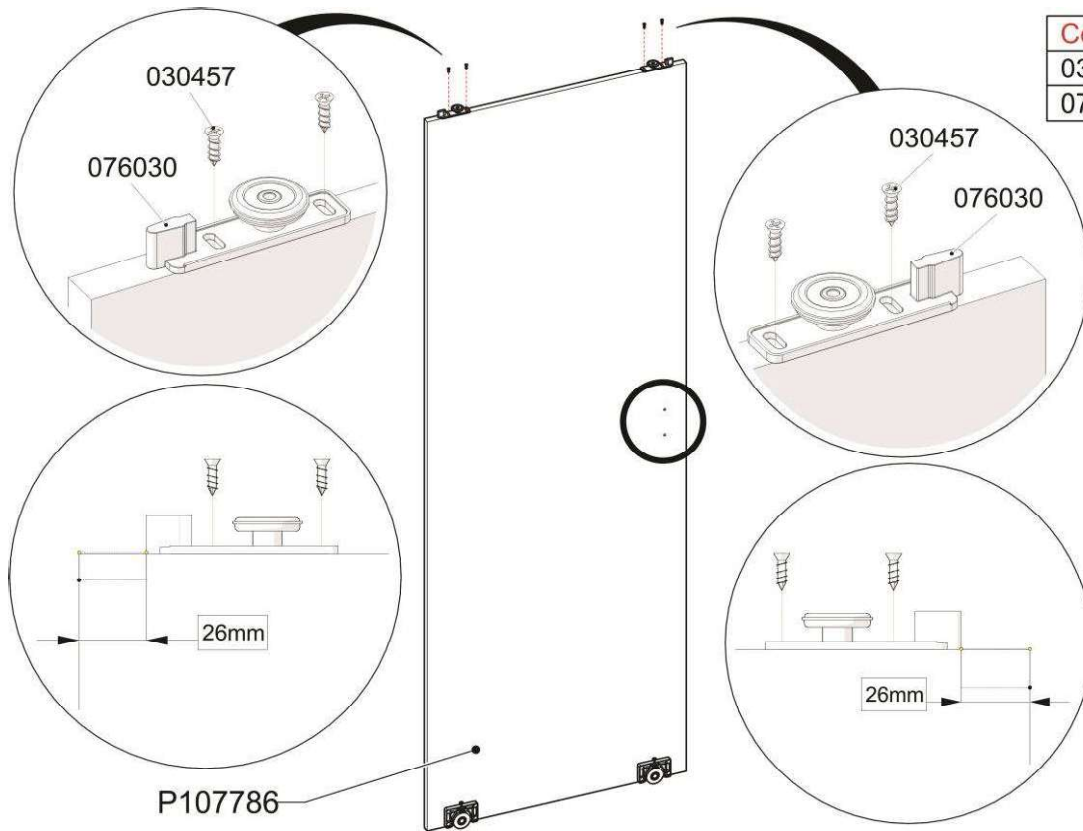

Cód.	Qtde.
030457	4
076030	2

PC002

PASSO / PASO / STEP 8

Cód.	Qtde.
030457	2
PX1	1

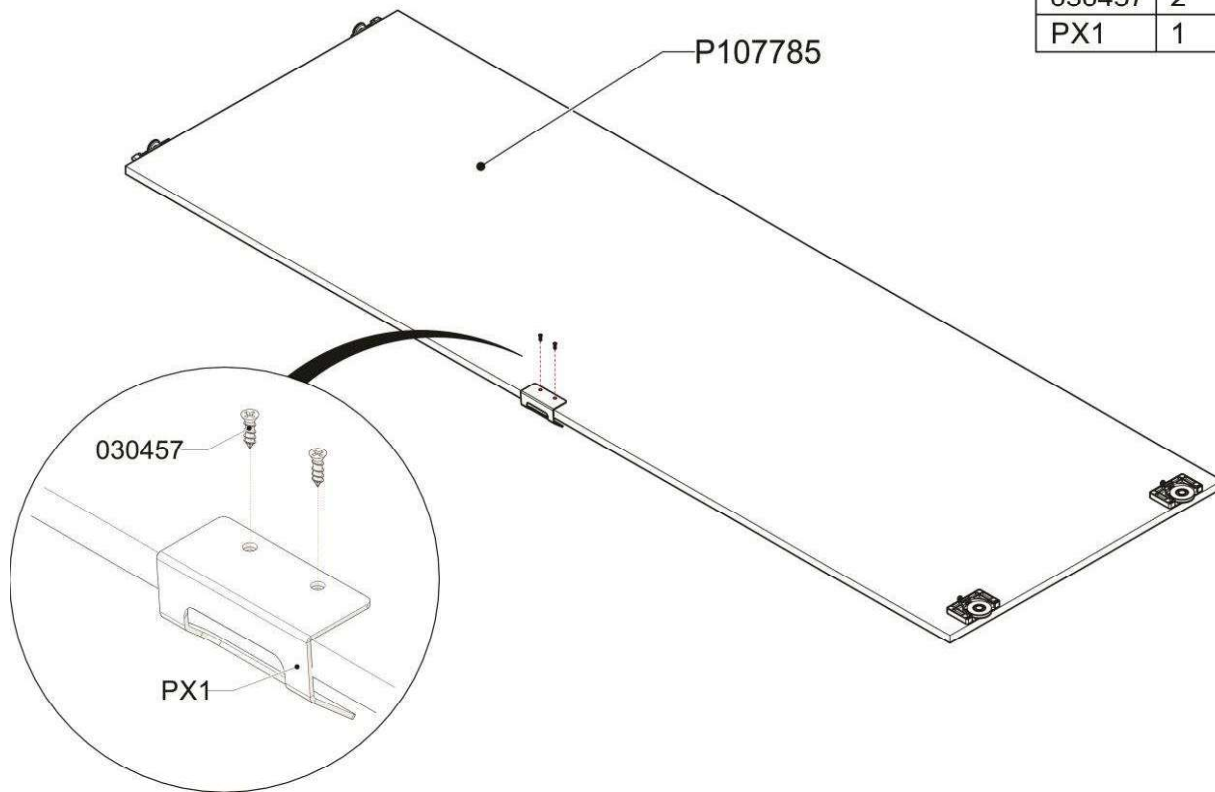

PASSO / PASO / STEP 9

Cód.	Qtde.
001178	4
PX2	2

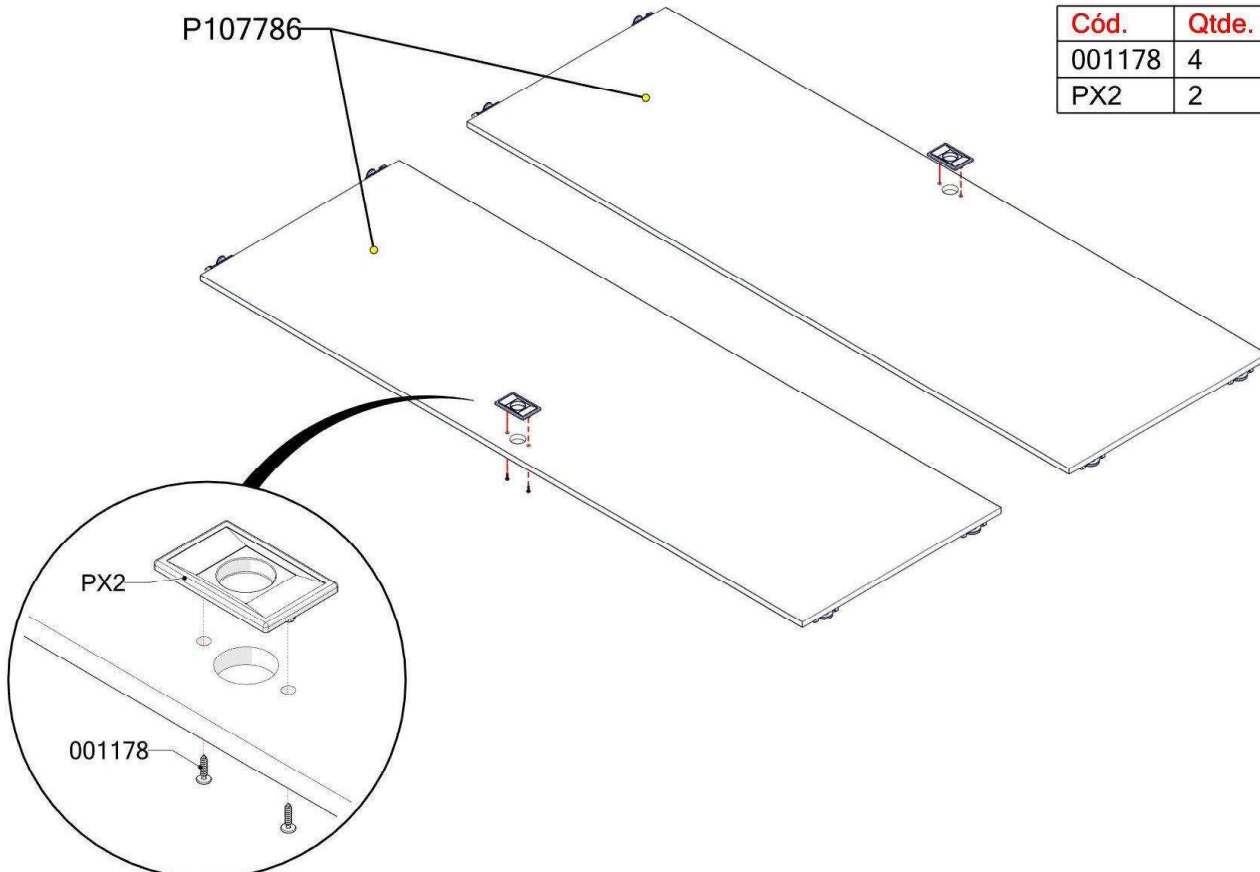

PASSO / PASO / STEP 10

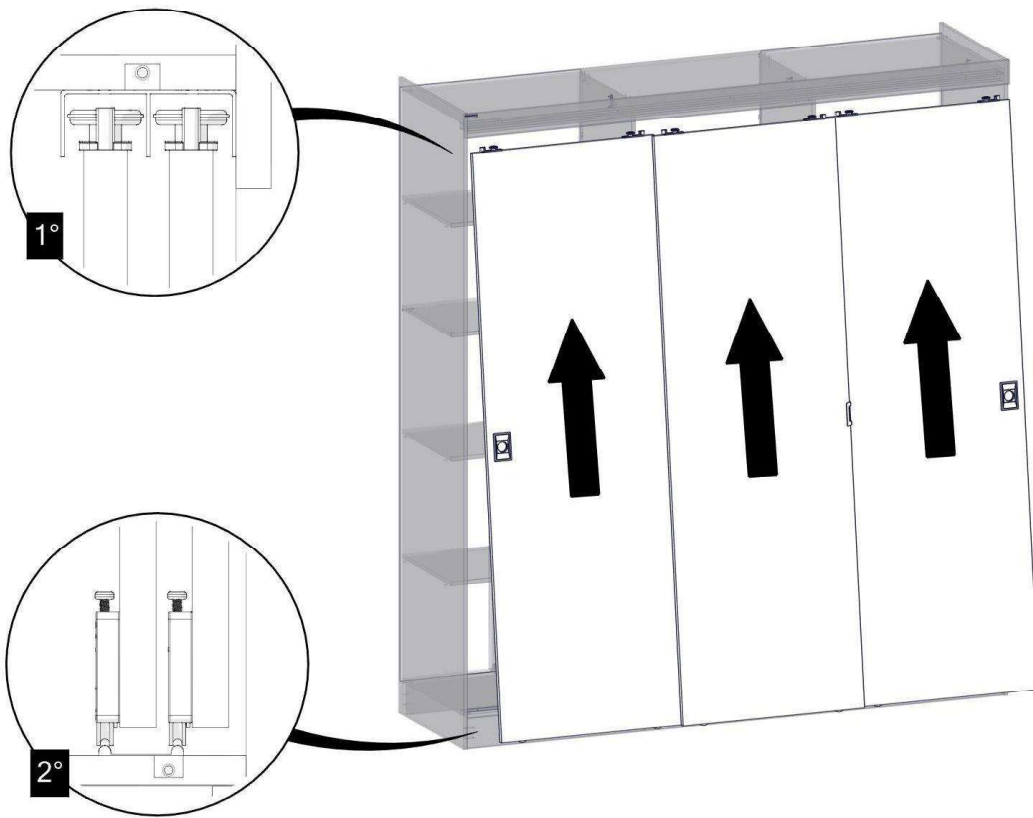

PASSO / PASO / STEP 11

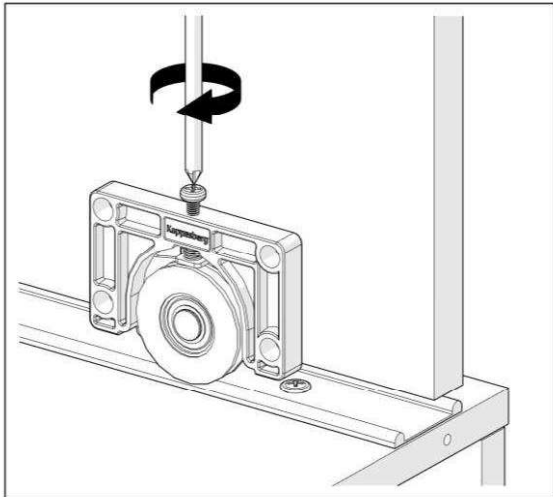

Após a instalação das portas, é necessário destravar as roldanas para que elas possam deslizar sobre o trilho.

Para isso, aperte o parafuso até as roldanas destravarem.

Después de instalar las puertas, es necesario desbloquear las roldanas para que puedan deslizarse sobre el riel.

Para ello, apriete el tornillo hasta que las roldanas se desbloqueen.

After installing the doors, it is necessary to unlock the rollers so they can slide on the track.

To do this, tighten the screw until the rollers unlock.

Limpeza / Limpieza / Cleaning:

- Retire o pó com uma flanela seca.
- Use um pano macio levemente umedecido com água para limpar.
- Se necessário, utilize detergente ou sabão neutro diluído em água.
- Não use produtos abrasivos para evitar danos ao móvel.

- Retire el polvo con un paño seco.
- Use un paño suave ligeramente humedecido con agua para limpiar.
- Si es necesario, utilice detergente o jabón neutro diluido en agua.
- No use productos abrasivos para evitar dañar el mueble.

- Dust with a dry cloth.
- Use a soft cloth slightly dampened with water for cleaning.
- If necessary, use detergent or neutral soap diluted in water.
- Do not use abrasive products to avoid damaging the furniture.

Conservação / Conservación / Maintenance:

- Proteja o móvel contra umidade excessiva.
- Evite exposição direta ao Sol ou fontes de calor.
- Não exceda o peso máximo indicado para prateleiras e gavetas.
- Aperte os parafusos periodicamente para manter a estabilidade.
- Para mover o móvel, levante-o em vez de arrastá-lo.
- Móveis pesados devem ser transportados por duas pessoas.

- Proteja el mueble de la humedad excesiva.
- Evite la exposición directa al sol o fuentes de calor.
- No exceda el peso máximo indicado para estantes y cajones.
- Apriete los tornillos periódicamente para mantener la estabilidad.
- Para mover el mueble, levántelo en lugar de arrastrarlo.
- Los muebles pesados deben ser transportados por dos personas.

- Protect the furniture from excessive moisture.
- Avoid direct exposure to the Sun or heat sources.
- Do not exceed the maximum weight indicated for shelves and drawers.
- Tighten the screws periodically to maintain stability.
- To move the furniture, lift it instead of dragging it.
- Heavy furniture should be moved by two people.

Garantia / Garantía / Warranty:

Garantia de 90 dias para defeitos de fabricação.
A garantia será anulada em caso de montagem incorreta ou uso inadequado.

Garantía de 90 días por defectos de fabricación.
La garantía se anulará en caso de montaje incorrecto o uso indebido.

90-day warranty for manufacturing defects.
The warranty will be voided in case of incorrect assembly or improper use.