

MANUAL DE MONTAGEM

ASSEMBLY INSTRUCTIONS

INSTRUCCIONES DE MONTAJE

NOTICE DE MONTAGE

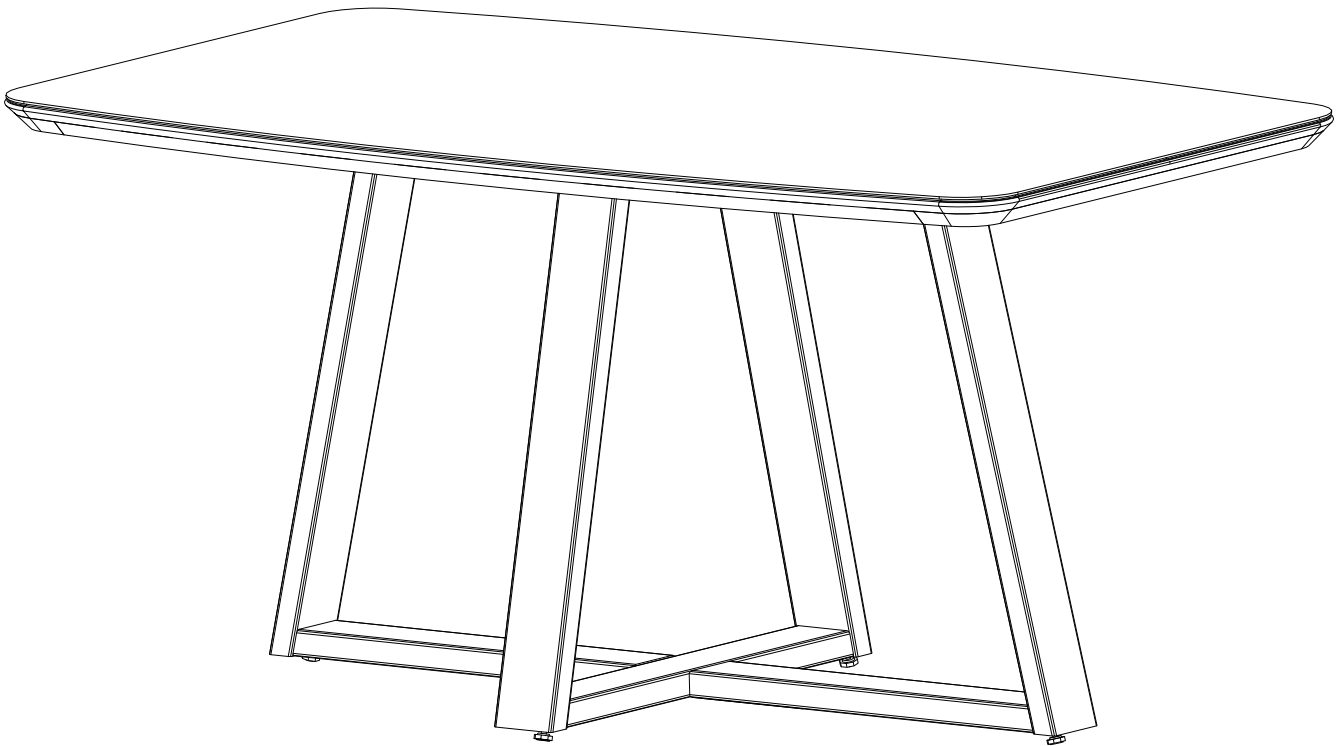

1.6

COD: 1031500

COD: 1018700

1.8

COD: 1031600

COD: 1021400

OBSERVAÇÕES IMPORTANTES IMPORTANT REMARKS OBSERVACIONES IMPORTANTES REMARQUES IMPORTANTES



Nunca escale ou se apoie sobre o móvel. Você pode sofrer graves acidentes.

Never climb or lean on the furniture. You may suffer serious accidents.

Nunca escale o apoie sobre el mobiliario. Usted puede sufrir accidentes graves.

Ne montez jamais sur le meuble. Vous pourriez subir un grave accident.



Movimente o móvel com cuidado, sem arrastar. Peça ajuda a outra pessoa para fazê-lo.

Move the piece carefully, don't drag it. Ask for someone else's help to do so.

Mover la unidad con cuidado, sin arrastar. Pedir ayuda da otra persona para moverlo.

Déplacez les meubles avec précaution sans le faire glisser. Demandez a quelqu'un de vous aider à le faire.



Limpe com um pano limpo e umedecido em água e sabão neutro. Não utilizar produtos químicos e abrasivos.

Wipe clean using a damp cloth and a mild cleaner. Don't use abrasive and chemical products.

Limpie con un paño limpiohumedecido con agua y jabón neutro. No utilice productos químicos y abrasivos.

Nettoyez avec un chiffon propre imbibé avec d'eau et de savon doux. N'utilisez pas de produits chimiques et abrasifs.

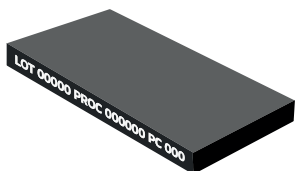

Observe os números impressos nas bordas para identificar as peças.

Identify the parts by observing the number printed on their edges.

Identifique las piezas observando el numero impresso en sus bordes.

Notez les numéros imprimés sur les bords pour identifier les pièces.

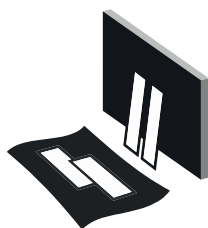

Utilize a embalagem para forrar a área de montagem e separar todas as peças.

Use the packaging to cover the assembly area and separate all parts.

Utilice el embalaje para cubrir la area de montaje y separe las piezas.

Couvrez la zone d'assemblage avec l'emballage pour séparer le pièces.



Não colocar objetos em alta temperatura diretamente sobre superfícies de vidro.

Do not place high-temperature objects directly on glass surfaces.

No coloque objetos de alta temperatura directamente sobre superficies de vidro.

Ne placez pas d'objets à haute température directment sur les surfaces en verre.

ACESSÓRIOS HARDWARE HERRAJES ACCESSOIRES

Identifique e separe os acessórios utilizados. Em cada embalagem, uma etiqueta identifica as peças e onde utilizá-las.

Identify and separate the hardware used in the assembly. There's a label on each package identifying the parts and where to use them.

Identifique y separe los accesorios utilizados en el montaje. Observe la etiqueta en cada paquete para saber donde montar.

Identifiez et séparez les accessoires à être utilisés. Dans chaque emballage il y a une étiquette pour identifier les pièces et où les utiliser.

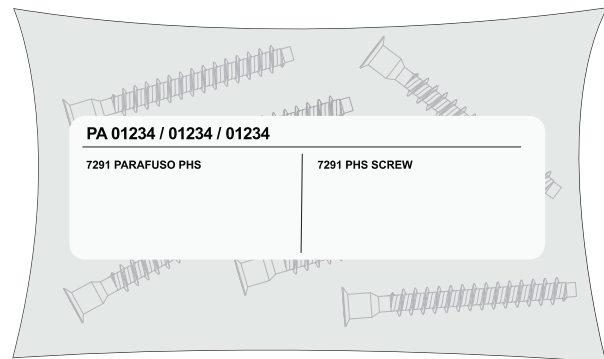







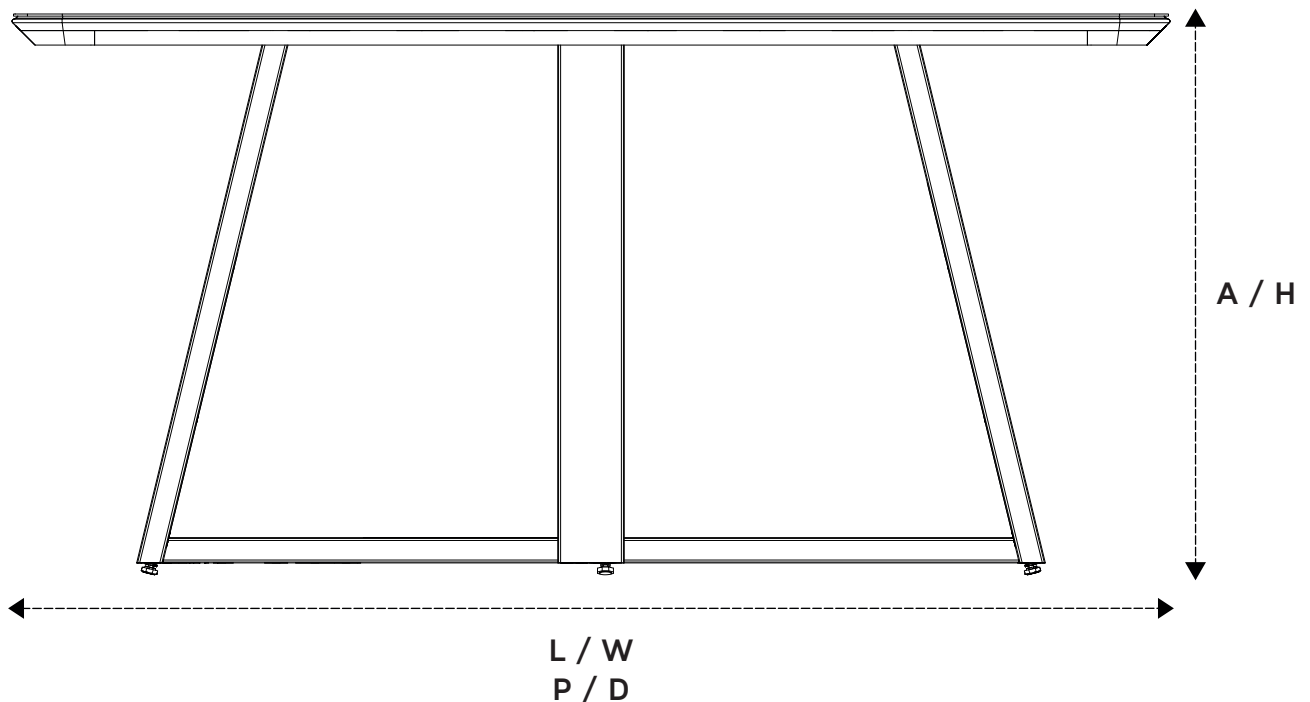

PA1031500 / PA1018700 - 1.6

L:1600mm A:773mm P:895mm
W:62.99in H:30.44in D:35.23in

PA1031600 / PA1021400 - 1.8

L:1800mm A:773mm P:895mm
W:70.86in H:30.44in D:35.23in

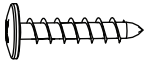
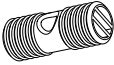

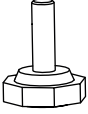
<p>A COD. 2077 (06X)</p> 	<p>B COD. 11698 M6 x 180 (01X)</p> 	<p>C COD. 9187 M6 x 75 (04X)</p> 	<p>D COD. 12925 (04X)</p> 	<p>E COD. 0329 8.0 x 30 (16X)</p> 
<p>F COD. 9509 (01X)</p> 	<p>G COD. 11701 6.0 x 30 (16X)</p> 	<p>H COD. 13515 (04X)</p> 	<p>I COD. 0634 (06X)</p> 	<p>J COD. 11588 (04X)</p> 

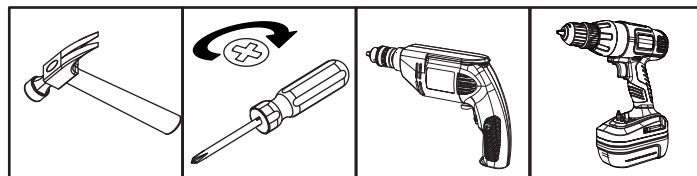

DESCRIÇÃO/ DESCRIPTION/ DESCRIPCIÓN/ DESCRIPTION

CÓD:1031500 / 1018700 / 1031600 / 1021400						
PEÇA PART PIEZA PIECE STÜCK	QUANTIDADE QUANTITY CANTIDAD QUANTITÉ MENGE	DESCRIÇÃO	DESCRIPTION	DESCRIPCIÓN	DESCRIPTION	CAIXA BOX CAJA BOÎTE BOX
18/20/24/25	01	TAMPO	TOP PANEL	PANEL SUPERIOR	PLATEAU	01
53	04	TRAVESSA LATERAL	SIDE CROSSPIECE	TRAVESAÑO LATERAL	TRAVERSE LATÉRALE	02
61	01	BASE CENTRAL	CENTER BASE	BASE CENTRAL	BASE CENTRALE	02
62	02	BASE	BASE	BASE	BASE	02
09	01	SUB-TAMPO	LOWER COVER	CUBIERTA INFERIOR	DESSUS	02

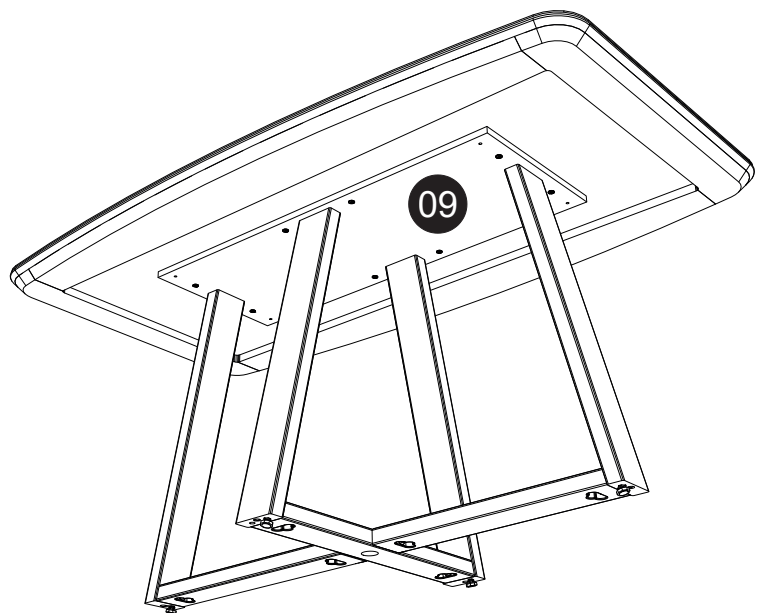
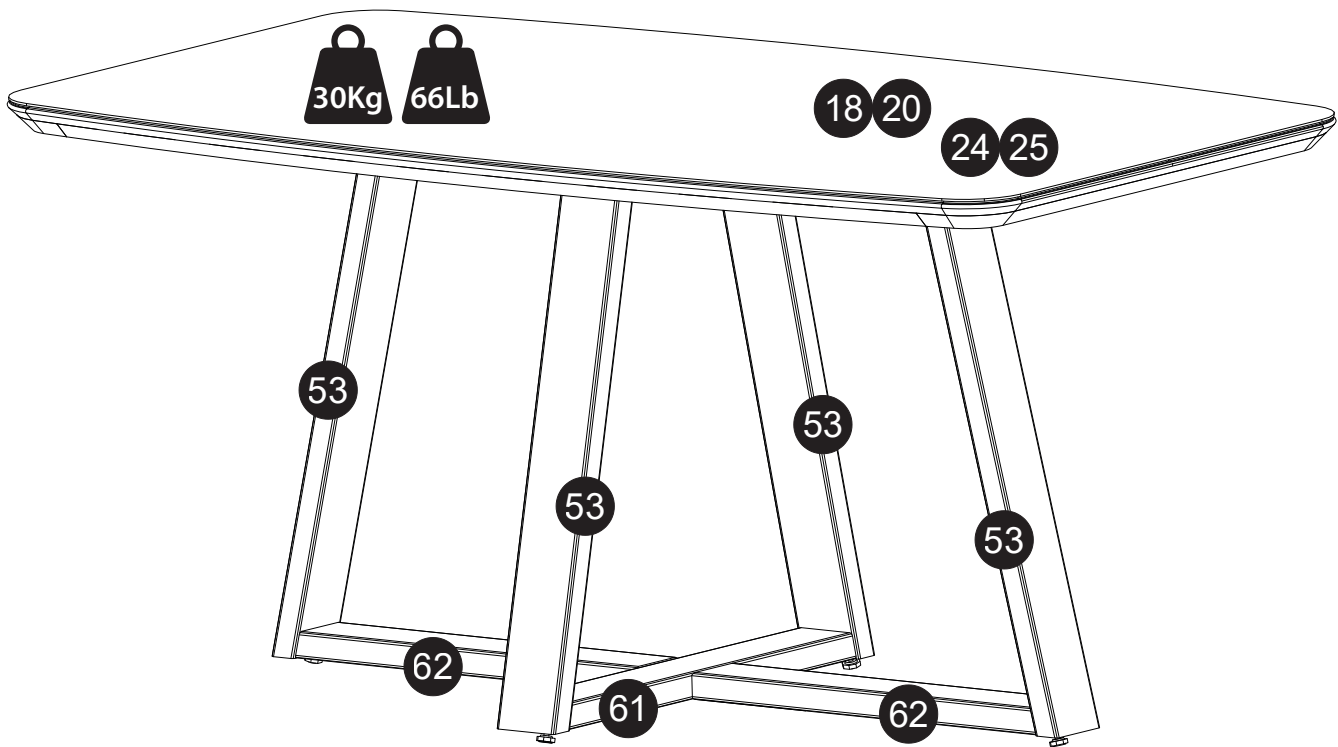

01

APLICAR COLA
APPLY GLUE
APLICAR EL PEGAMENTO
APPLIQUEZ LA COLLE

A COD. 2077	B COD. 11698	E COD. 0329	I COD. 0634	F COD. 9509

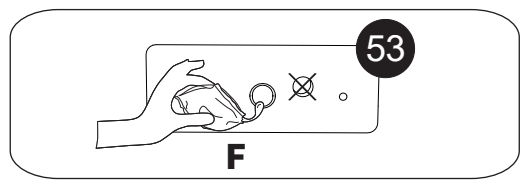
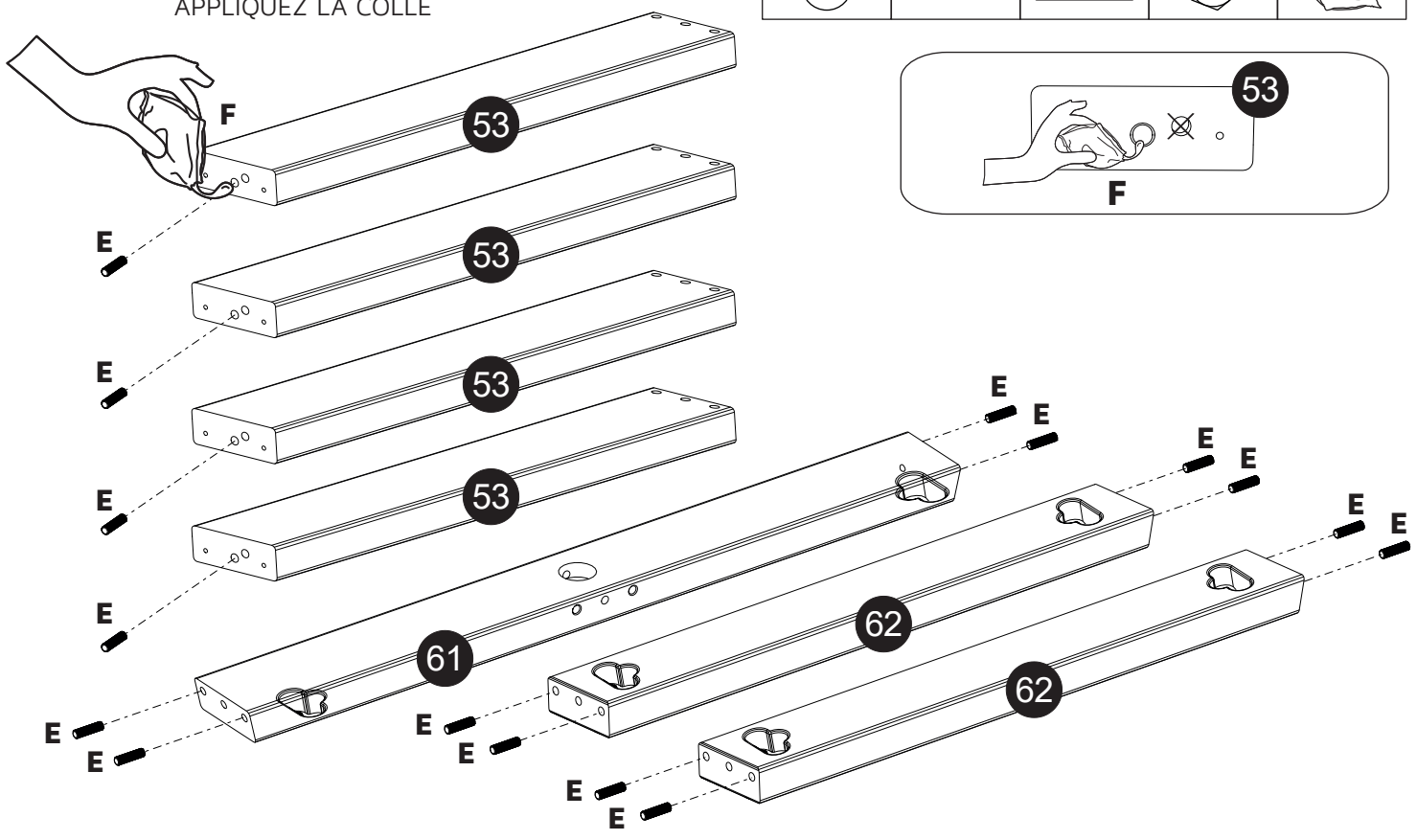



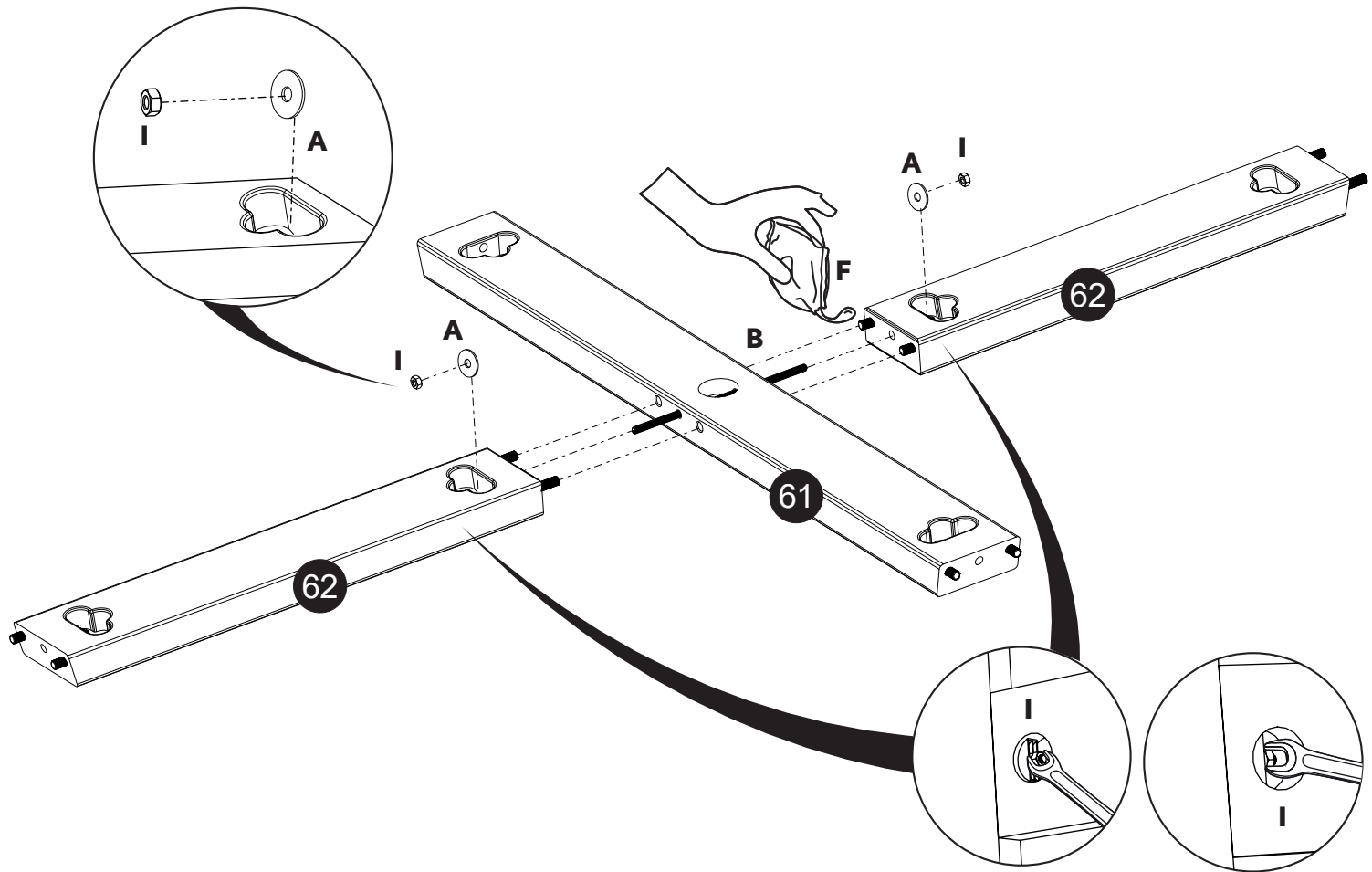



02



03

APLICAR COLA
 APPLY GLUE
 APLICAR EL PEGAMENTO
 APPLIQUEZ LA COLLE

A COD. 2077	C COD. 9187	D COD. 12925	H COD. 13515	I COD. 0634	J COD. 11588	F COD. 9509
						

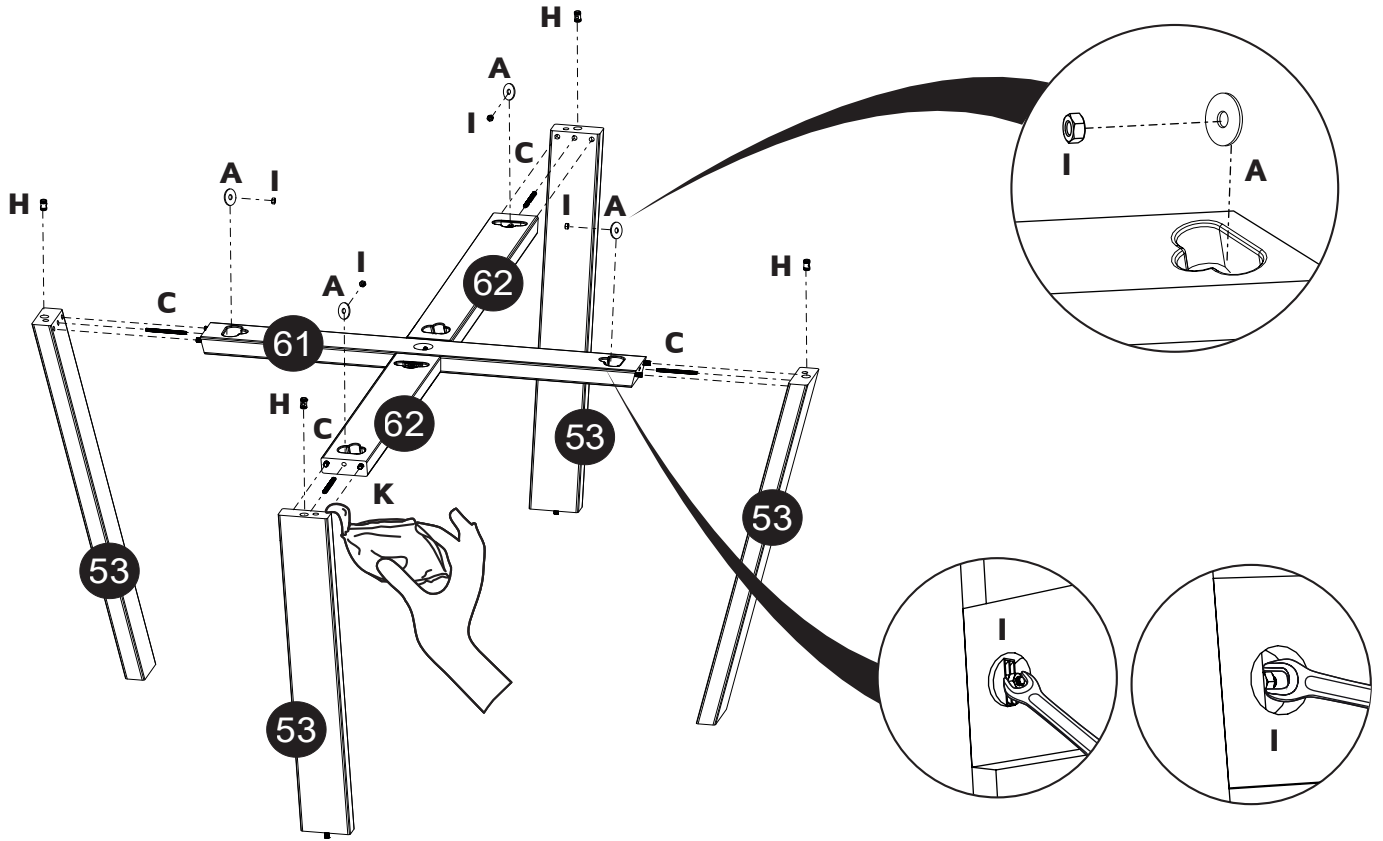

04

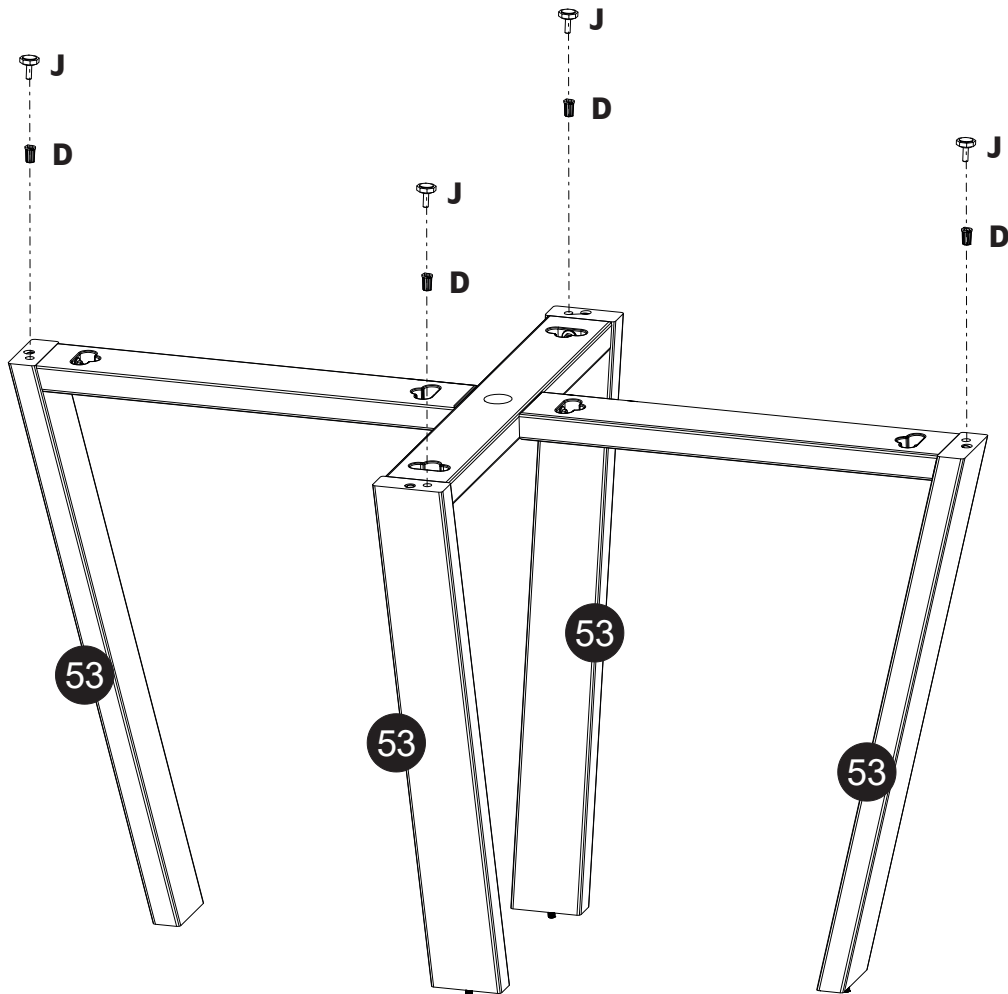

05

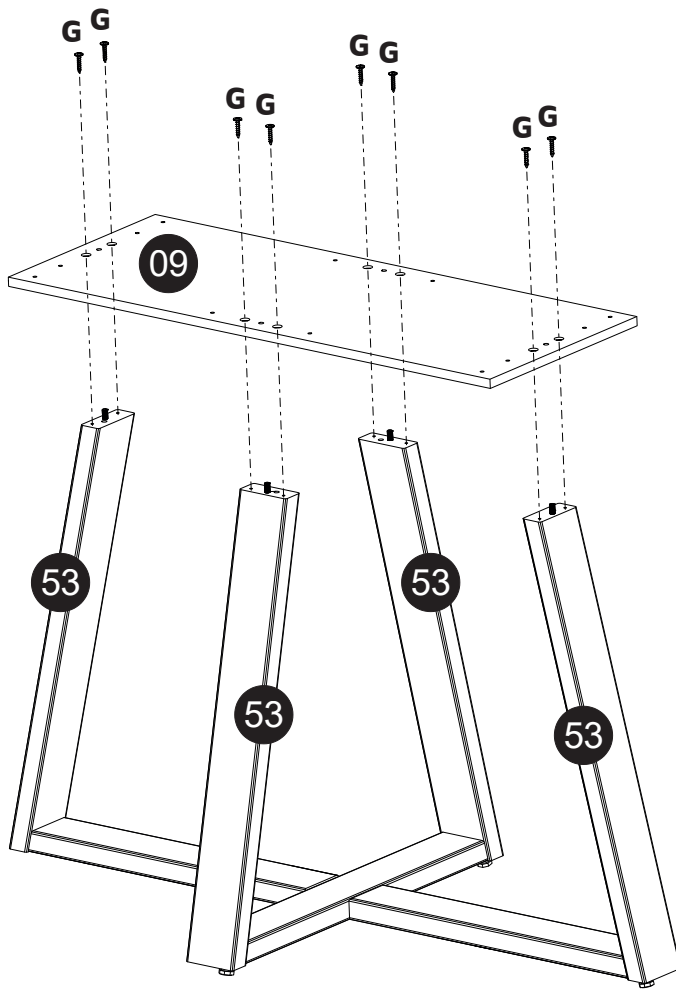

G
COD. 11701

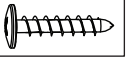

Atenção
Attention
Atención
Attention



COD. 11701 - 08X
6.0 x 30

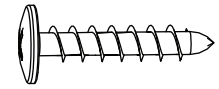

G

06



Atenção
Attention
Atención
Attention

1.6
L1= 108mm / 4.26 in
L2= 216mm / 8.51 in

1.8
L1= 108mm / 4.26 in
L2= 315mm / 12.41 in

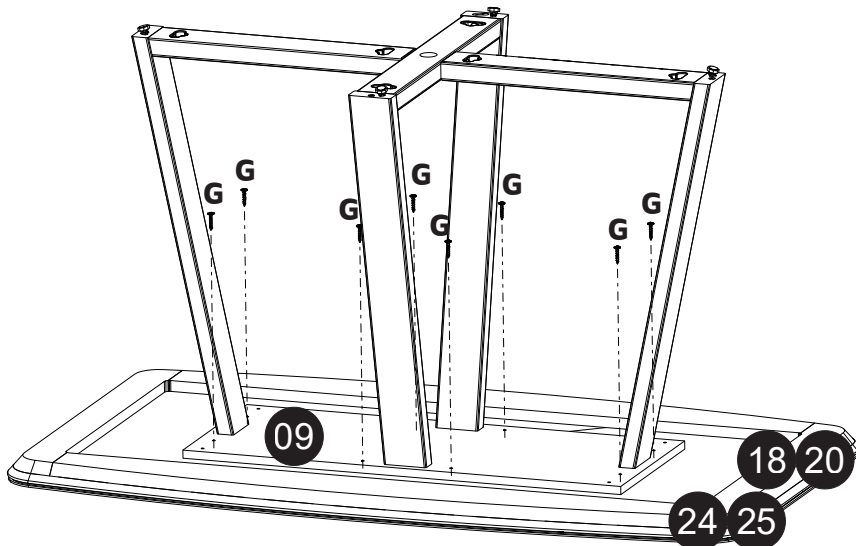
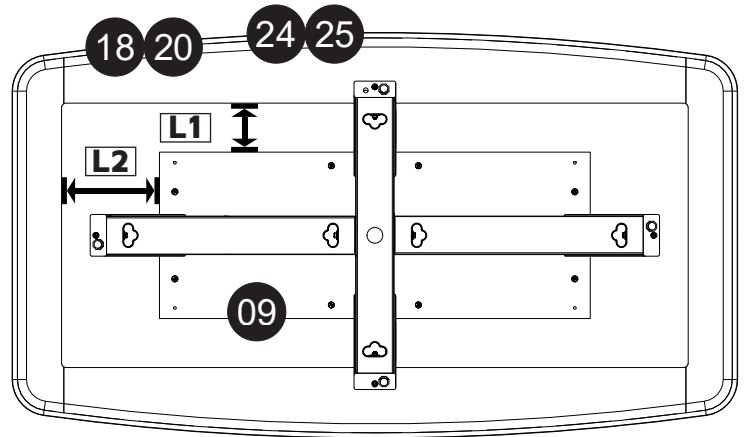

Atenção
Attention
Atención
Attention



COD. 11701 - 08X
6.0 x 30

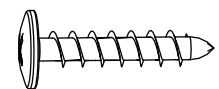

G