

**CÓDIGO DE PEÇAS | CODE OF PIECES | CÓDIGO DE PIEZAS**

**VISTA FRONTAL | FRONT VIEW**

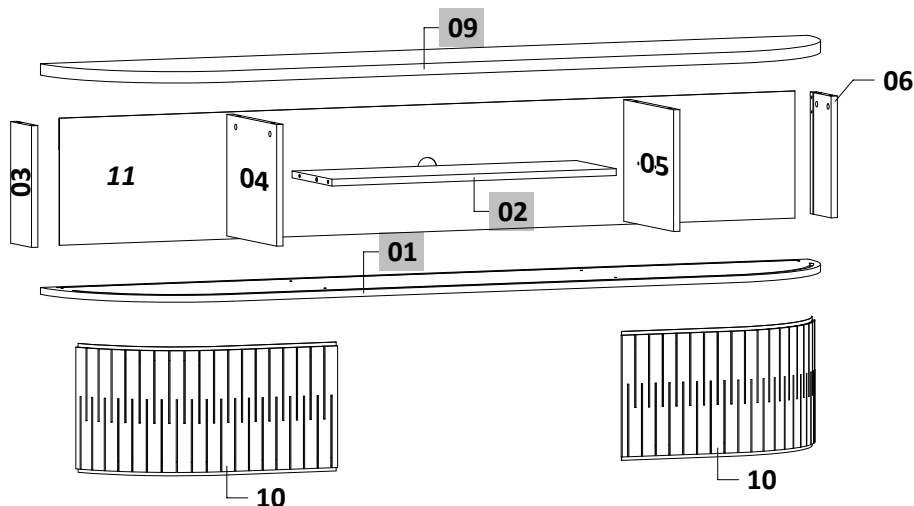

**VISTA TRASEIRA | BACK VIEW / VISTA TRASERA**

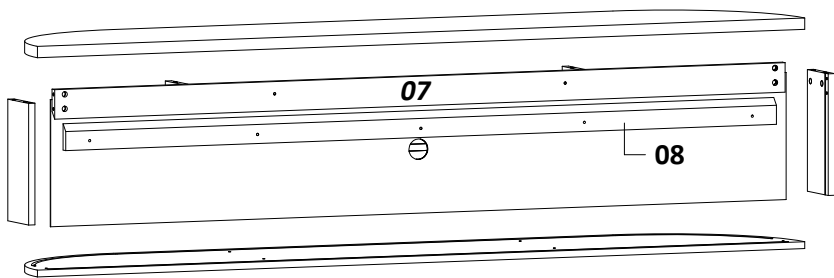

**INSTRUÇÕES DE MONTAGEM | ASSEMBLY INSTRUCTIONS | INSTRUCCIONES DE MONTAJE**

- Prepare a montagem do móvel próximo ao local que ele ficará definitivamente e evite deslocá-lo depois de montado;
- Forre o chão com papelão ou similar e utilize a isomanta que vem entre as peças para evitar o contato entre elas durante a montagem;
- Monte o móvel obedecendo a ordem numérica da **sequência de montagem (S.M.)**, identificando as peças pelo **código de peça (C.P.)** carimbado na mesma, de acordo com a tabela.
- Prepare the assembly of the close piece of furniture to the place that it will be definitively and avoid to move after done. Will be definitively and avoid to move after done;
- Cover the ground with cardboard or similar and use the isomanta that it comes among the pieces to avoid the contact among them during the assembly;
- Set up the piece of furniture obeying the numeric order of the **assembly sequence (S.M.)**, identifying the pieces by **code of piece (C.P.)** stamped in the same, in agreement with the table.
- Prepare la montaje del mobiliario proximo al lugar que estará definitivamente y evite mover después de hecho;
- Tape la suelo con cartón o similar y use la "isomanta" que viene entre las piezas para evitar el contacto entre ellos durante la montaje;
- Monte el mobiliario obedeciendo el orden numérico de la **sucesión de montaje (S.M.)**, identificando las piezas por el **código de piezas (C.P.)** de la misma estampado en esta, de acuerdo con la tabla.

**Ferramentas necessárias para montagem (não fornecidas)**  
Tools required for assembly (not supplied)  
Herramientas necesarias para el montaje (no suministradas)



Parafusadeira  
Screwdriver  
Destornillador

Chave de  
Fenda e Phillips

Martelo / Hammer  
Martillo

**Pessoas necessárias para montagem**  
People needed for assembly  
Personas necesarias para el montaje

**Tempo Montagem**  
Assembly time  
Tiempo montaje



1 pessoa / people / persona



60 min

**CUIDADOS ESPECIAIS | SPECIAL CARES | CUIDADOS ESPECIALES:**

**LIMPEZA:** Pano limpo umedecido em água e sabão neutro - **BRILHO:** Flanela seca  
**CLEANING:** Clean cloth humidified in water and neutral soap - **SHINE:** Dry flannel  
**LIMPIEZA:** Tela limpia humedecida en la agua y el jabón neutro - **BRILLO:** Flanela seca

**ASPECTO FINAL | FINAL ASPECT**

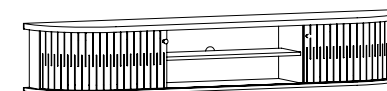

→1,830 m ↑ 0,310 m ↯ 0,330 m

**Dimensão do Produto:**  
Product dimensions:  
Dimensiones del producto:

**PESO SUPORTADO**  
**WEIGHT SUPPORTED**  
**PESO SOPORTADO**

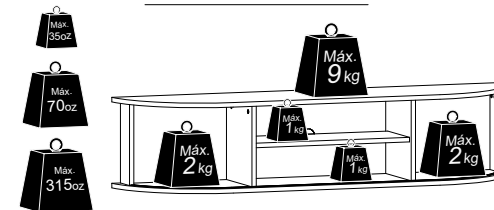

REF.:	CÓDIGO DA PEÇA   CODE PIECE   CÓDIGO DE PIEZA				DESCRIÇÃO DA PEÇA PART DESCRIPTION DESCRIPCIÓN DE PIEZA	MATÉRIA PRIMA FEEDSTOCK	DIMENSÕES DIMENSIONS DIMENSIONES	QUANT. AMOUNT CANTIDAD
	FENDI NATURALE	CALACATA OFF WHITE	CINAMOMO OFF WHITE	CUMARU OPALA				
01	203793.029	203793.033	203793.037	203793.037	Base   Base   Base	MDP	1,830 x 0,326 x 0,015	1
02	203794.029	203794.026	203794.037	203794.037	Prateleira   Shelf   Estante	MDP	0,678 x 0,224 x 0,015	1
03	203795.029	203795.026	203795.037	203795.037	Lateral esquerda   Left side   Lateral izquierdo	MDP	0,268 x 0,117 x 0,015	1
04	203796.029	203796.026	203796.037	203796.037	Divisão esquerda   Left split   División izquierda	MDP	0,280 x 0,268 x 0,015	1
05	203797.029	203797.026	203797.037	203797.037	Divisão direita   Right split   División derecha	MDP	0,280 x 0,268 x 0,015	1
06	203798.029	203798.026	203798.037	203798.037	Lateral direita   Right side   Lateral derecho	MDP	0,268 x 0,117 x 0,015	1
07	203799.009	203799.009	203799.009	203799.009	Apoio da bancada   Caucus support   Apoyo del caucus	MDP	1,742 x 0,065 x 0,015	1
08	203800.009	203800.009	203800.009	203800.009	Apoio da parede   Wall support   Soporte de pared	MDP	1,695 x 0,058 x 0,015	1
09	203801.029	203801.033	203801.037	203801.037	Tampo   Top   Tampo	MDF	1,830 x 0,326 x 0,025	1
10	203802.027	203802.026	203802.026	203802.026	Porta deslizante   Sliding door   Puerta deslizante	MDF	0,617 x 0,258 x 0,006	2
11	203803.029	203803.026	203803.037	203803.037	Fundo   Bottom   Fondo	MDF	1,754 x 0,280 x 0,003	1
<b>LEGENDA DAS CORES   COLOR LEGEND   LEYENDA DE COLOR</b>								
<b>009 - SEM PINTURA   UNPAINTED   SIN PINTAR</b>			<b>026 - OFF WHITE</b>		<b>027 - NATURALE</b>		<b>029 - FENDI</b>	
<b>033 - CALACATA</b>			<b>037 - CINAMOMO</b>		<b>039 - CUMARU</b>		<b>040 - OPALA</b>	

# ACESSÓRIOS | ACCESSORIES | ACCESORIOS

## PARAFUSOS | Screw | Tornillo



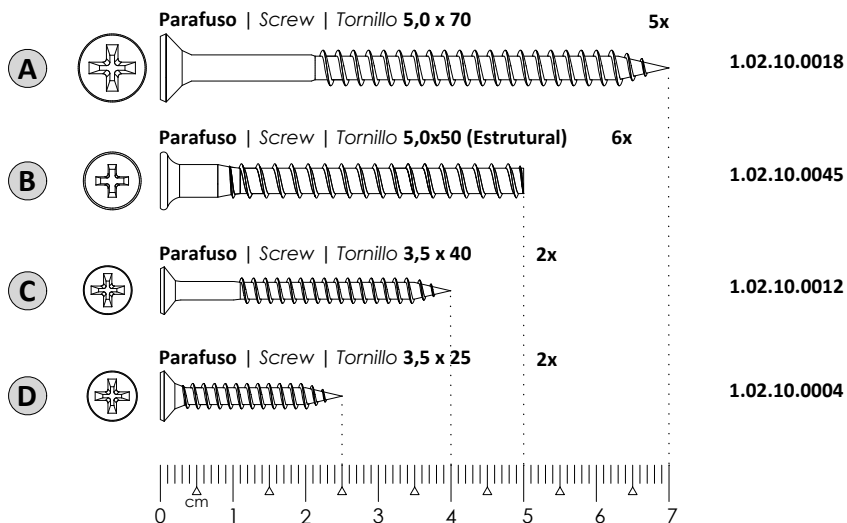

## CÓDIGO | CODE

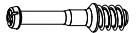

### RELAÇÃO DE COR DOS ACESSÓRIOS

Color ratio of accessories | Relación de color de los accesorios

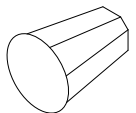
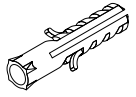
LETRA LETTER	DESCRIÇÃO DESCRIPTION DESCRIPCIÓN	MATÉRIA PRIMA FEEDSTOCK	COR COLOR	QUANT.   AMOUNT   CANTIDAD				CÓDIGO CODE
				FENDI NATURALE	CALACATA OFF WHITE	CINAMOMO OFF WHITE	CUMARU OPALA	
<b>N</b>	Tapa furo adesivo 18mm Adhesive hole cover 18mm Tapa agujero adhesivo 18mm	Papel Paper	Off White		6		6	102080216
			Fendi	6			102080245	
			Cinamomo			6	102080286	
			Opala			6	102080289	
<b>O</b>	Giz p/ correção Touch-up chalk Tiza correctora	Cera Wax	Calacata / Off White		1	1		102140008
			Naturale	1			102140009	
			Fendi	1			102140011	
			Cinamomo			1	102140023	
			Cumaru			1	102140026	
			Opala			1	102140025	
<b>P</b>	Trilho flexível 4/8 1915mm Flexible rail 4/8 1915 mm Carril flexible 4/8 1915mm	Plástico Plastic	Fendi	1				102070641
			Off White		1			102070640
			Cinamomo			1		102070647
			Cumaru				1	102070651

LETRA LETTER	DESCRIÇÃO DESCRIPTION DESCRIPCIÓN	MATÉRIA PRIMA FEEDSTOCK	QUANTIDADE AMOUNT CANTIDAD	CÓDIGO CODE
<b>E</b>	 Pino girofix 5,0x30mm Girofix pin 5,0x30mm Pino girofix 5,0x30mm	Metal	12	102050007
<b>F</b>	 Cavilha 6x30mm Dowel 6x30mm Clavija 6x30mm	Madeira Wood Madera	12	102050001
<b>G</b>	 Castanha girofix 12x10mm Girofix chestnut 12x10mm Castaña girofix 12x10mm	Metal	12	102050006
<b>H</b>	 Puxador diamante Diamond handle Tirador de diamante	Plástico Plastic	2	102020047
<b>i</b>	 Bucha para parede 8mm Bucha for wall 8mm Buja para pared 8mm	Plástico Plastic	5	102060079
<b>J</b>	 Etiqueta resinada Resin label Etiqueta en resina	Plástico Plastic	1	102080013
<b>N</b>	 Sache de Silicone 10g Silicone sachet 0,42oz Bolsita de silicone 0,42oz	Silicone Silicona	1	102050047

**1º PASSO | PASS | PASO**

PEÇAS  
PIECES  
PIEZAS

S.M.	C.P.
01	04
02	02
03	05

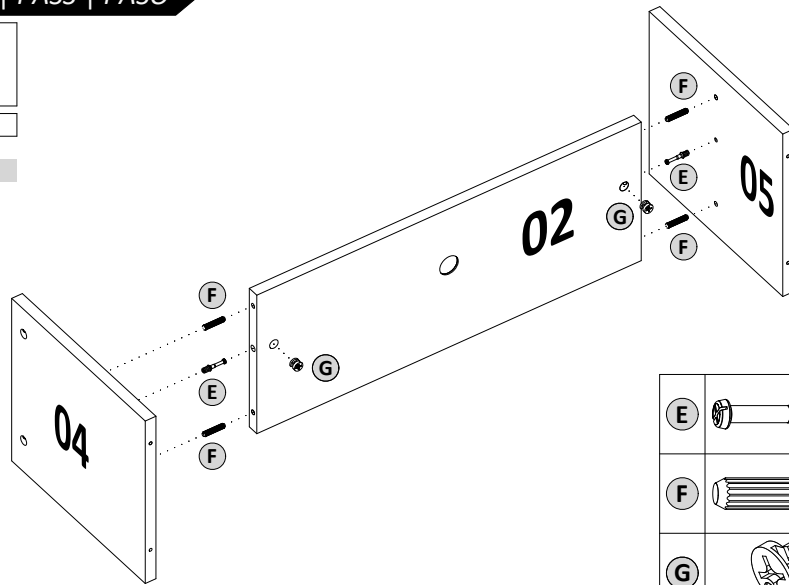

E		2
F		4
G		2

**2º PASSO | PASS | PASO**

PEÇAS  
PIECES  
PIEZAS

S.M.	C.P.
01	01

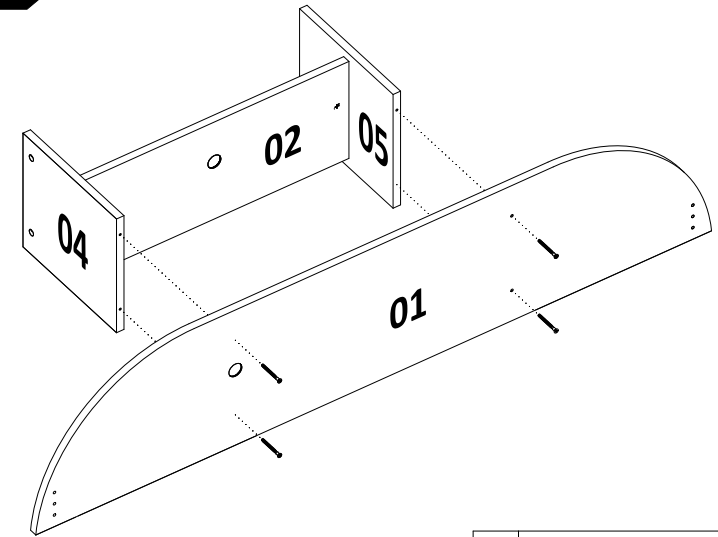

B		3
---	--	---

**3º PASSO | PASS | PASO**

PEÇAS  
PIECES  
PIEZAS

S.M.	C.P.
01	01
02	06
03	03
04	07
05	11

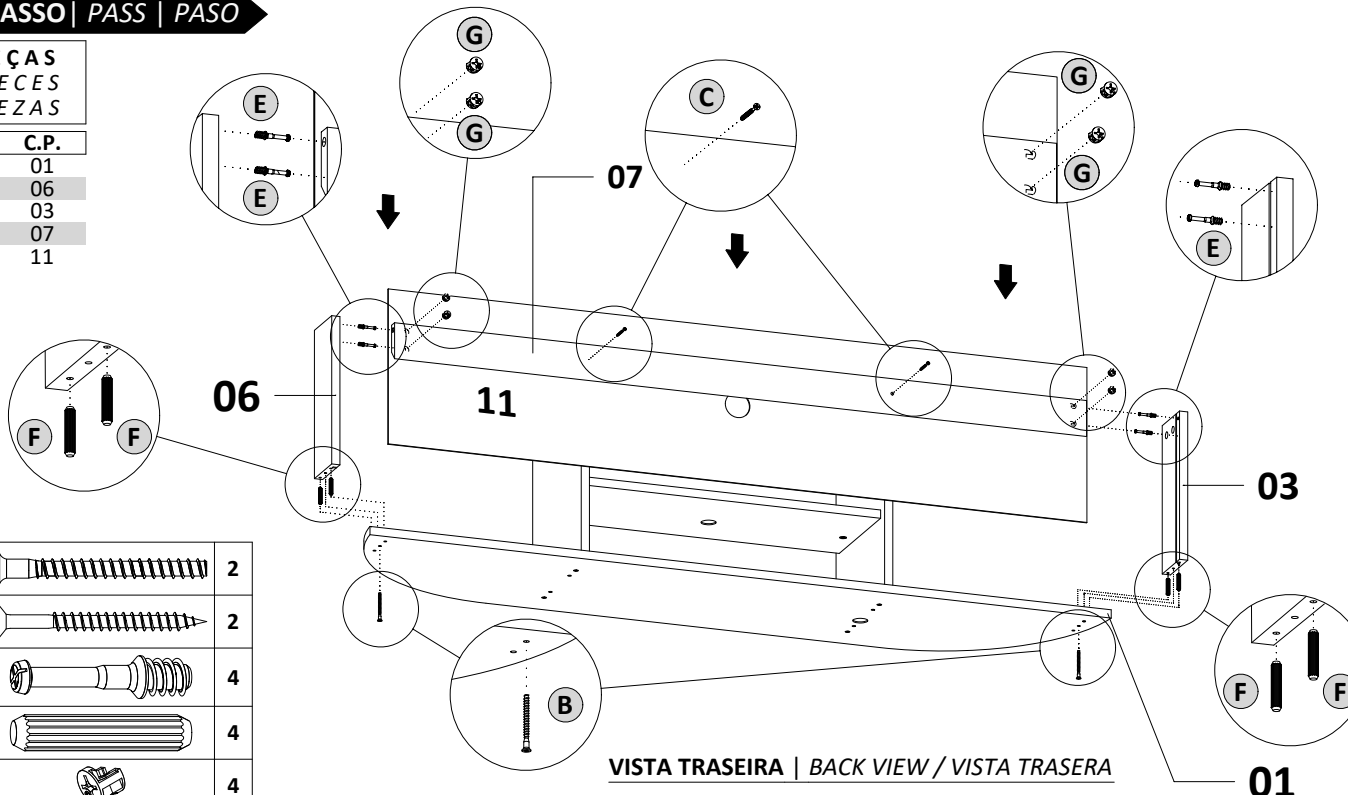

B		2
C		2
E		4
F		4
G		4

VISTA TRASEIRA | BACK VIEW / VISTA TRASERA

**4º PASSO | PASS | PASO**

PEÇAS  
PIECES  
PIEZAS

S.M.	C.P.
01	09

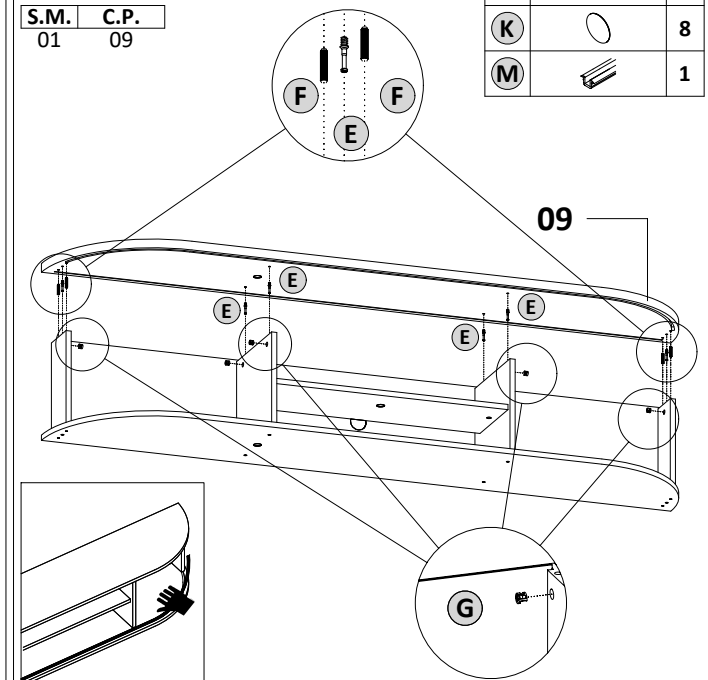



E		8
F		4
G		8
K		8
M		1

**5º PASSO | PASS | PASO**

PEÇAS  
PIECES  
PIEZAS

S.M.	C.P.
01	10
02	10

(A)		2
(M)		2

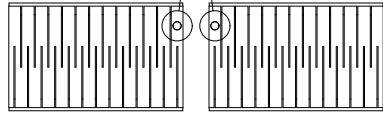
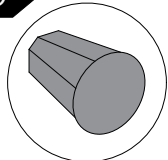

Porta esquerda  
Door left  
Puerta Izquierda

Porta direita  
Door right  
Puerta derecha

**NÃO** devem ser montado as portas conforme imagens abaixo

The doors should NOT be mounted as shown below:

Las puertas NO deben montarse como se muestra a continuación:

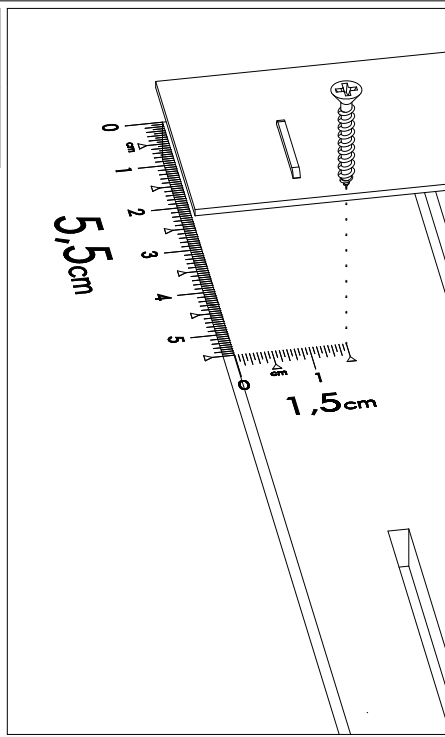
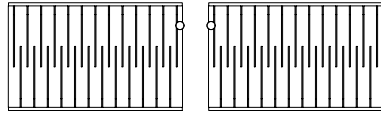

**6º PASSO | PASS | PASO**

**Encaixando a parte superior da porta no canal superior**  
Snapping the top of the port in the top channel  
Rompiendo la parte superior del puerto en el canal superior

Soltar os pinos girofix para encaixar as portas conforme imagem  
Release the girofix pins to fit the doors as shown in the image  
Suelte los pasadores girofix para que se ajusten a las puertas como se muestra en la imagen

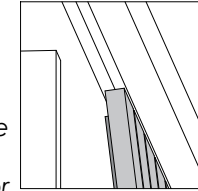

Soltar os pinos girofix para encaixar as portas conforme imagem  
Release the girofix pins to fit the doors as shown in the image  
Suelte los pasadores girofix para que se ajusten a las puertas como se muestra en la imagen

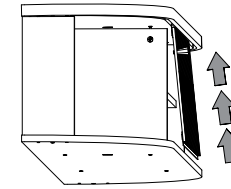

PORTA / DOOR / PUERTA

**Encaixando a parte inferior da porta no canal do trilho**  
Snapping the bottom of the door on the rail channel  
Rompiendo la parte inferior de la puerta en el canal ferroviario

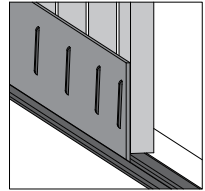
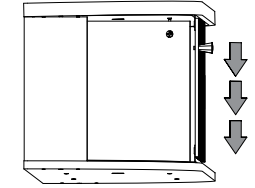



PORTA / DOOR / PUERTA

**7º PASSO | PASS | PASO**

PEÇAS  
PIECES  
PIEZAS

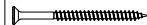
S.M.	C.P.
01	08

(A)		5
(i)		5

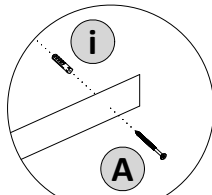

(N)	SILICONE	1
-----	----------	---

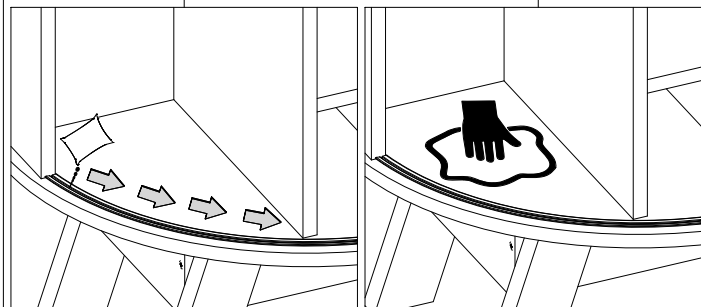
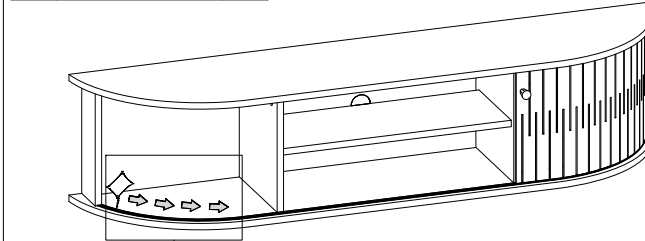

Parede | Wall | Pared

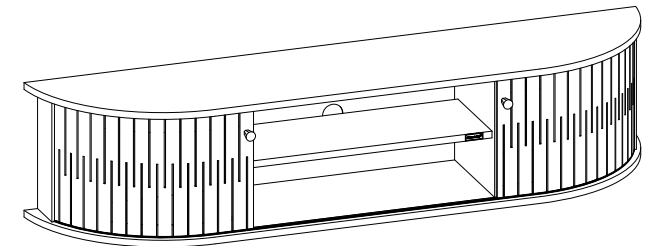

Medida do piso até o furo da parede  
Measure from floor to wall hole  
Mida desde el suelo hasta el agujero de la pared.

Parede | Wall | Pared  
08

