

MANUAL DE MONTAGEM / ASSEMBLY INSTRUCTIONS / PLANO DE ARMADO

Antes de montar o móvel, leia com atenção o manual de montagem!
Before assembling the furniture, carefully read the assembly instructions!
Antes de armar el mueble, lea con atención el manual de ensamble!

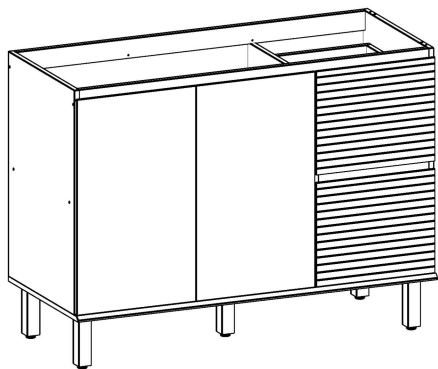

Ref.: 1550

genialflex
ambientes incríveis para todos

Parabéns! Você comprou um produto de excelente qualidade, fabricado com chapa de madeira de MDP ou MDF, extraída de florestas renováveis. Possui alta resistência e design atual.

Congratulations! You have purchased a product of excellent quality, made from MDP or MDF wood veneer, extracted from renewable forests. It has high strength and current design.

Felicitaciones! Usted compró a un producto de excelente calidad, fabricado con placa de madera de MDP o MDF, proveniente de florestas renovables. Tiene alta resistencia y diseño actual.



ATENÇÃO
ATTENTION
ATENCIÓN

- 1) Verifique todas as peças antes de começar a montagem.
Check all parts before starting assembly.
Verifique todas las partes antes de empezar el armado.
- 2) Ao começar a montagem, não apoie as peças na parede.
When starting the assembly, do not support the parts on the wall.
Al empezar el armado, no apoyes las partes en la pared.

- 3) Ao colocar as peças e ferragens de lado, cuidado para não perde-las.
When placing parts and hardware aside, be careful not to lose them.
Al poner las piezas y herrages a parte, cuidado para no dañarlas.

- 4) O móvel deve ser montado no chão, para isso, use a própria caixa para proteger e não danificar o piso.
The furniture must be mounted on the floor, to do this, use the box itself to protect and not damage the floor.
El mueble suele ser armado al piso, para eso, use la propia caja para protegerlo y no dañar al piso.

- 5) Comece a montagem seguindo as instruções passo a passo.
Begin assembly by following the step-by-step instructions.
Comience el armado siguiendo la instrucciones paso a paso.

- 6) É de responsabilidade do montador seguir as intruções desse manual, que são fundamentais para a estrutura do móvel.
It's the assembler's responsibility to follow the instructions in this manual, which are fundamental to the structure of the furniture.
Es de responsabilidad del armador seguir las instrucciones de este manual, que son fundamentales para la estructura del mueble.

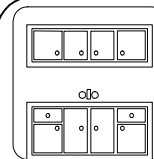

CUIDADOS
CARE
CUIDADO

- 1) A conservação e limpeza deve ser feita com um pano levemente umedecido com água.
Care and cleaning should be done with a cloth slightly moistened with water.
La conservación y limpieza debe ser hecha con un trapo levemente humedecido en agua.

- 2) Não use produtos abrasivos, como saponáceo, detergentes e esponja de aço.
Do not use abrasive products, such as soap, detergents and steel sponge.
No use productos abrasivos, como saponáceo, detergentes y esponja de acero.

- 3) Não use cera ou óleo para dar brilho ao móvel.
Do not use wax or oil to shine the furniture.
No use cera o aceites para darle brillo al mueble.

- 4) Não expor o móvel a interpéries e nem ao calor excessivo.
Do not expose the furniture to weather or excessive heat.
No exponer el mueble a interperies ni al calor excesivo.

- 5) Ao terminar a montagem, limpe o ambiente e o móvel.
When the assembly is finished, clean the room and the furniture.
Al terminar el armado, limpie al ambiente y al mueble.

FERRAMENTAS / TOOLS / HERRAMIENTAS



MARTELO
HAMMER
MARTILLO



MARTELO DE BORRACHA
RUBBER HAMMER
MARTILLO GOMA



CHAVE PHILLIPS
PHILLIPS SCREWDRIVER
LLAVE PHILLIPS



TRENA
MEASURING TAPE
CINTA MÉTRICA









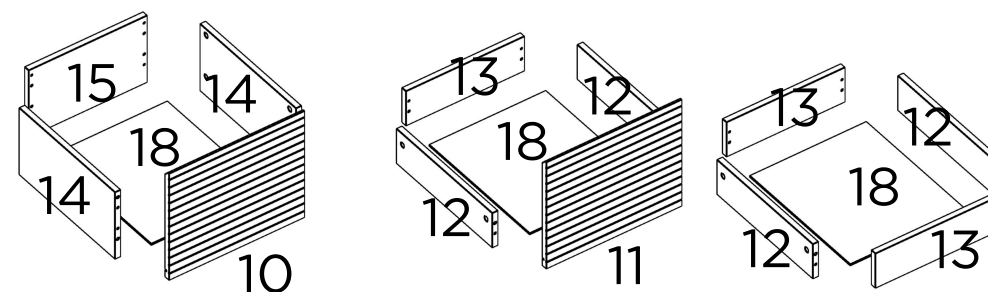
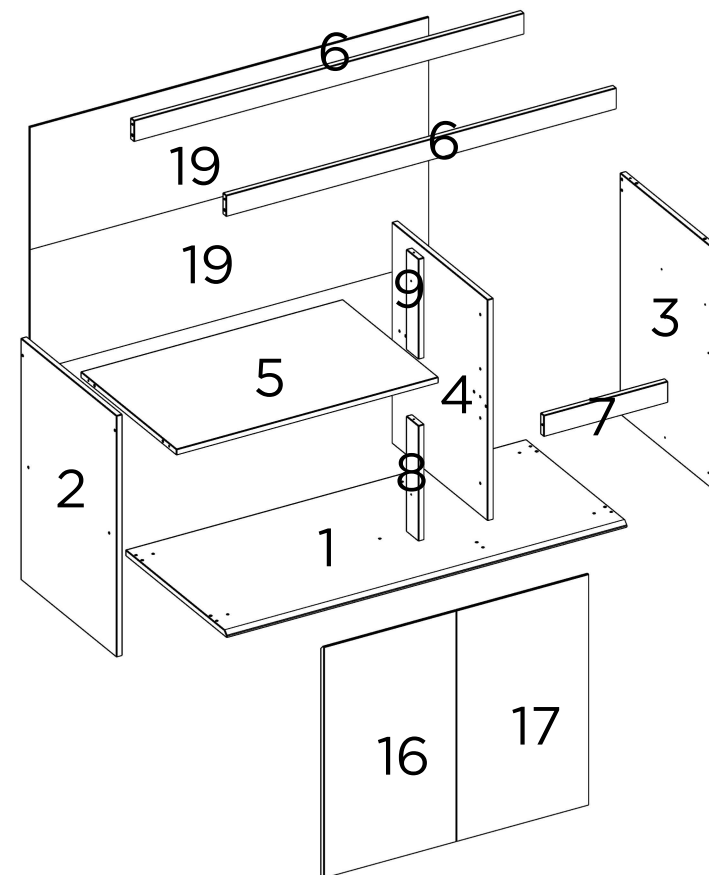



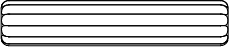
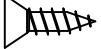

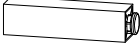

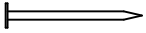
PARAFUSADEIRA
DRILL/ELETRIC
SCREWDRIVER
DESTORNILLADOR
ELÉCTRICO

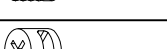
PEÇAS / PARTS / PIEZAS		
Nº No Num	DESCRIÇÃO DESCRIPTION DESCRIPCIÓN	QTD QTY CANT
1	BASE 45 GRAUS - BOTTOM 45 DEGREES - BASE 45 GRADOS	1
2	LATERAL ESQUERDA - LEFT SIDE PANEL LATERAL IZQUIERDA	1
3	LATERAL DIREITA - RIGHT SIDE PANEL LATERAL DERECHO	1
4	DIVISÓRIA - DIVISION DIVISIÓN	1
5	PRATELEIRA - PLATE PANEL - REPISA	1
6	TRAVESSA FRONTAL/TRASEIRA - FRONTAL/BACK PLATE TRAVESAÑO FRONTAL/TRASERO	2
7	TRAVESSA INFERIOR - LOWER CROSS - TRAVESAÑO INFERIOR	1
8	PILAstra MAIOR - BIGGER PILLAR PILAR MAIOR	1
9	PILAstra MENOR - SMALLER PILLAR PILAR MENOR	2
10	FRENTE DE GAVETA 45 GRAUS INFERIOR -LOWER DRAWER FRONT 45 DEGREES FRENTE DEL CAJÓN INFERIOR 45 GRADOS	2
11	FRENTE DE GAVETA 45 GRAUS SUPERIOR -TOP DRAWER FRONT 45 DEGREES FRENTE DEL CAJÓN SUPERIOR 45 GRADOS	1
12	LATERAL DE GAVETA - DRAWER SIDE LATERAL DEL CAJÓN	4
13	COSTA DE GAVETA - DRAWER BACK TRASERO DEL CAJÓN	3
14	LATERAL DE GAVETÃO - DRAWER SIDE LATERAL DEL CAJÓN	2
15	COSTA DE GAVETÃO - LARGER DRAWER BACK TRASERO DEL CAJÓN MAYOR	1
16	PORTA ESQUERDA 45 GRAUS - LEFT DOOR 45 DEGREES - PUERTA IZQUIERDA 45 GRADOS	1
17	PORTA DIREITA 45 GRAUS - RIGHT DOOR 45 DEGREES - PUERTA DERECHO 45 GRADOS	1

18	FUNDO DE GAVETA - DRAWER BOTTOM PANEL FONDO DEL CAJÓN	1
19	COSTA - BACK PANEL TRASERO	1



FERRAGENS / HARDWARE / HERRAJES

CÓD CODE COD	DESCRIÇÃO DESCRIPTION DESCRIPCIÓN	QTD QTY CANT
A	 CABILHA WOODEN DOWEL TARUGO	30
B	 PARAFUSO 4X12mm SCREW 4X12mm TORNILLO 4X12mm	56
C	 CORREDEÇA LATERAL SIDE SLIDE CORREDERA LATERAL	6
D	 PARAFUSO 5X50mm SCREW 5X50mm TORNILLO 5X50mm	5
E	 PÉ LEG PATA	5
F	 PARAFUSO 3,5X40mm SCREW 3,5X40mm TORNILLO 3,5X40mm	14
G	 PARAFUSO 3,5X25mm SCREW 3,5X25mm TORNILLO 3,5X25mm	9
H	 PREGO NAIL CLAVO	50
I	 GARRA METÁLICA METALLIC CLAW GRAB METALICA	10
J	 PARAFUSO MINIFIX MINIFIX SCREW TORNILLO MINIFIX	16
K	 TAMBOR MINIFIX MINIFIX DRUM TAMBOR MINIFIX	16
L	 PREGO ANELADO RINGED NAIL CLAVO ANILLADO	30
M	 CORREDEÇA GAVETA DRAWER SLIDE CORREDERA DEL CAJÓN	6
P	 TAPA-FURO MAIOR BIGGER HOLE COVER TAPA AGUJERO MAYOR	16
Q	 CALÇO PARA DOBRADIÇA HINGE SHED CALZO DE BISAGRA	4
R	 DOBRADIÇA HINGE BIZAGRA	4
S	 TAPA-FURO MENOR SMALL HOLE COVER TAPA AGUJERO MINOR	8
T	 CANTONEIRA DE 2 FUROS METALLIC ANGLE CANTONERA 2 AGUJEROS	8

UTILIZE A RÉGUA PARA IDENTIFICAR OS PARAFUSOS
USE THE RULER TO IDENTIFY THE SCREWS
UTILICE LA REGLA PARA IDENTIFICAR LOS TORNILLOS

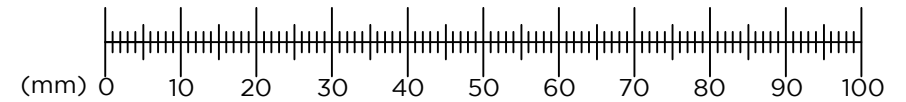

PESO SUPORTADO / WEIGHT SUPPORTED / PESO SOPORTADO

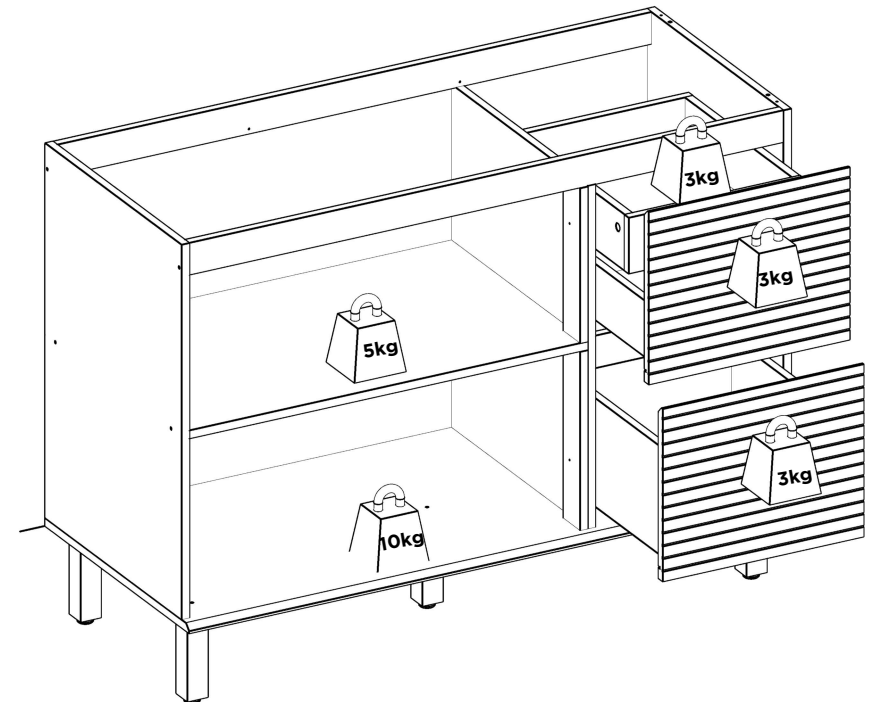

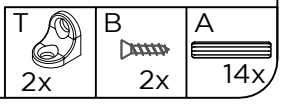
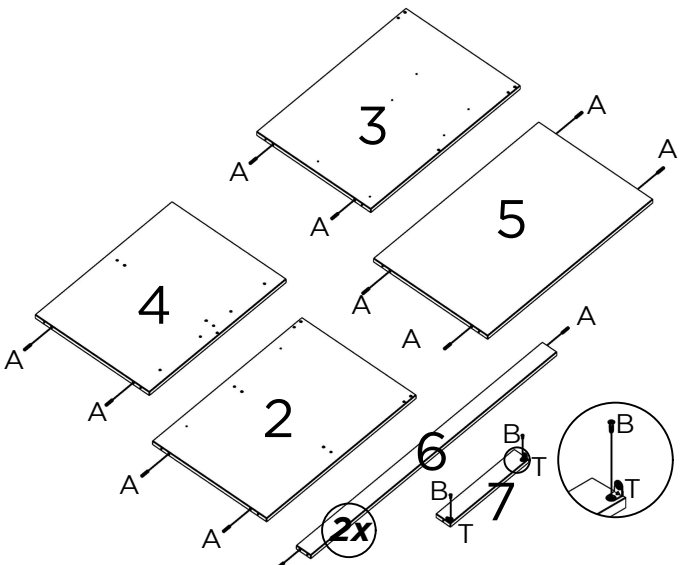
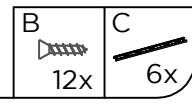
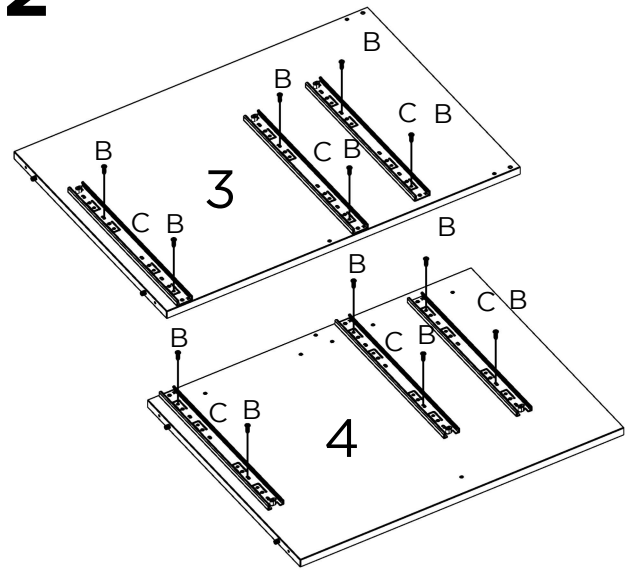
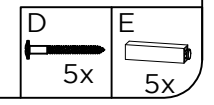
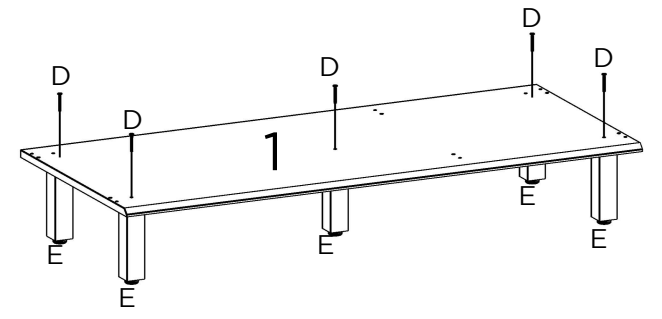
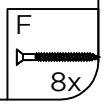
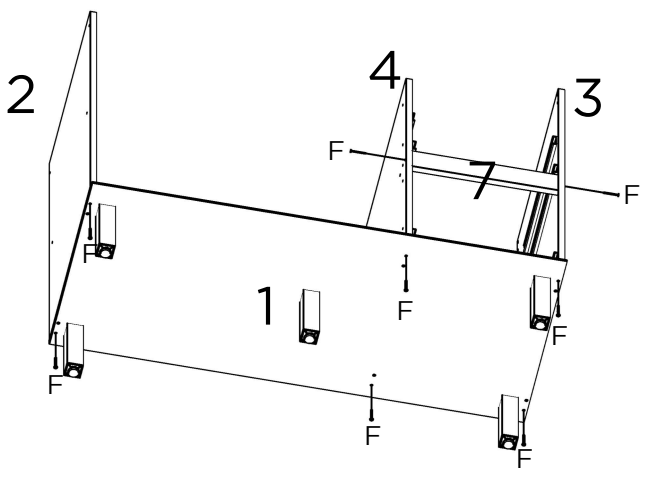
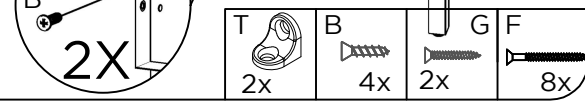
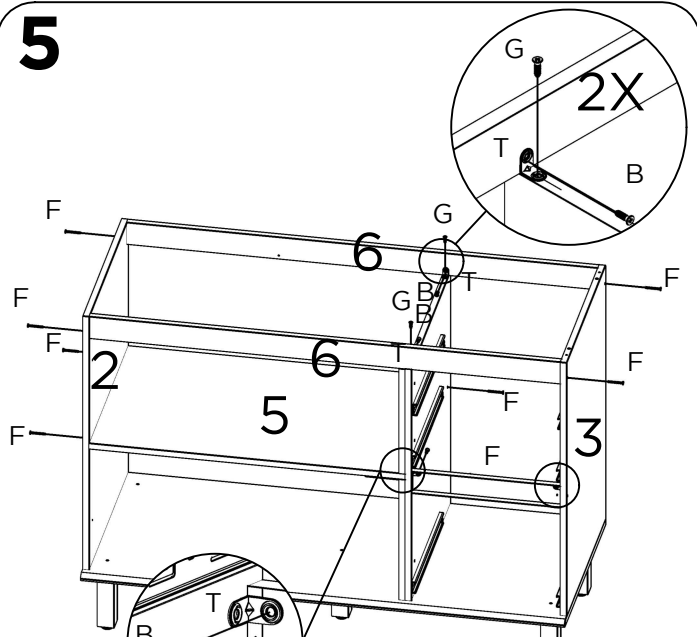
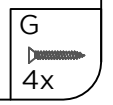
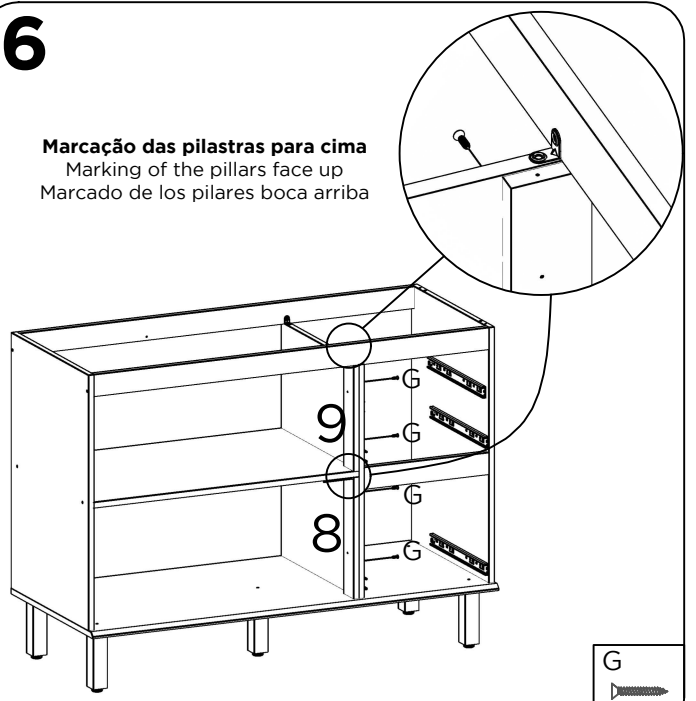
1**2****3****4****5****6**

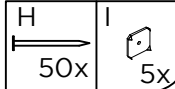
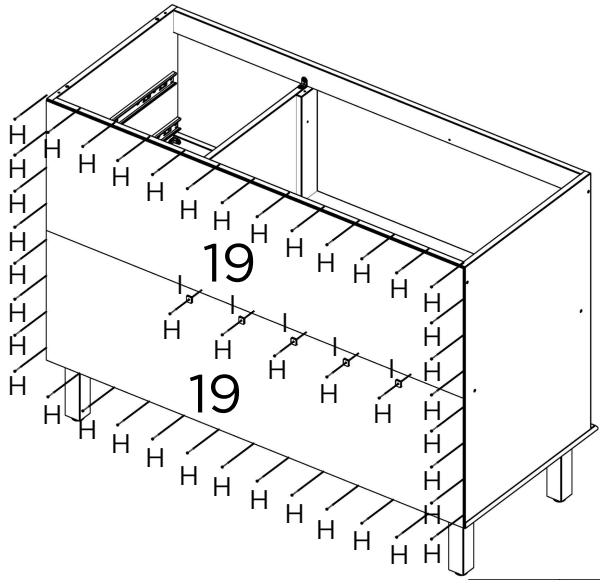
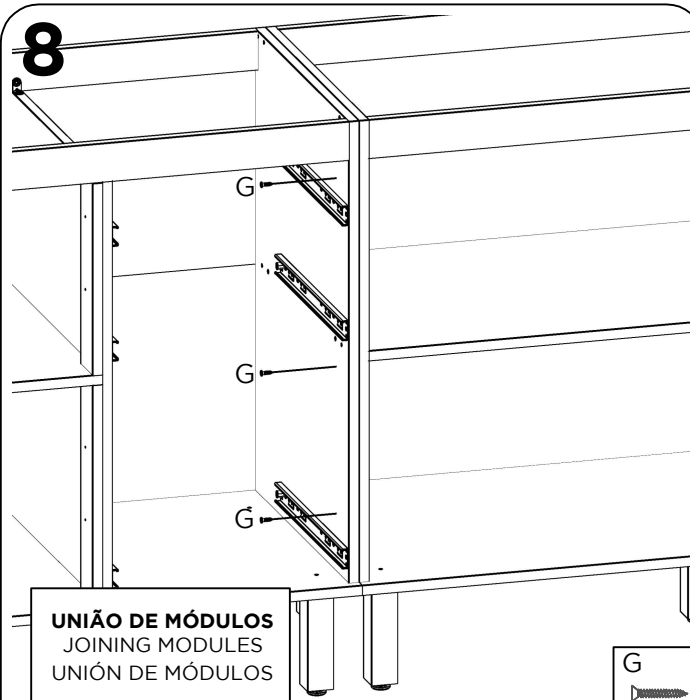
7**8**

UNIÃO DE MÓDULOS
JOINING MODULES
UNIÓN DE MÓDULOS

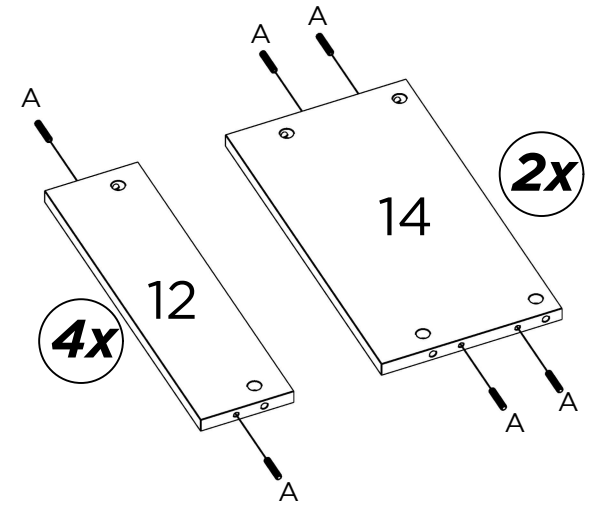
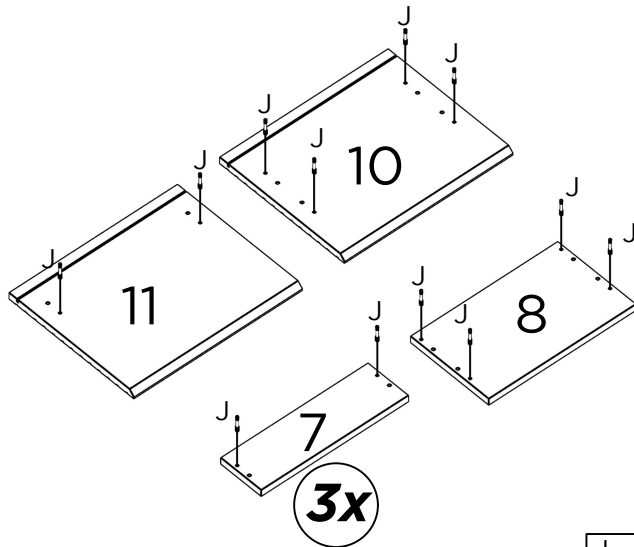
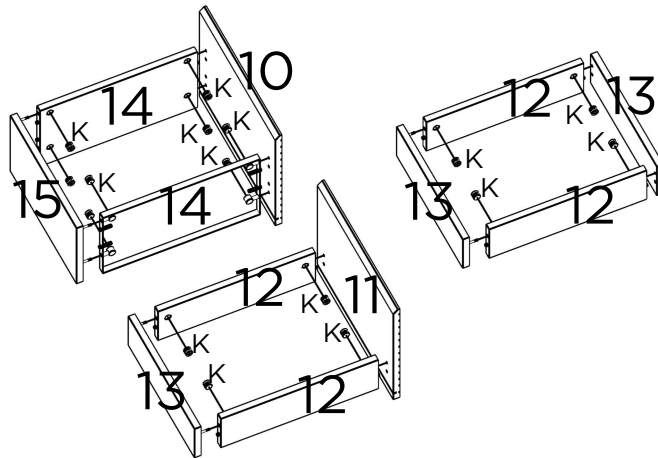
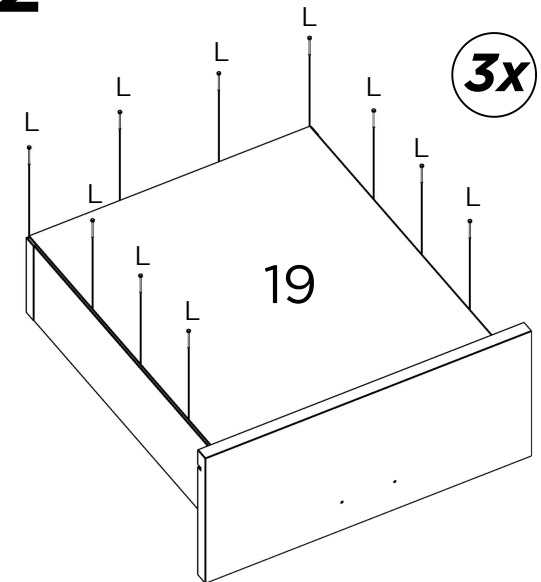
**9****10****11****12**

13

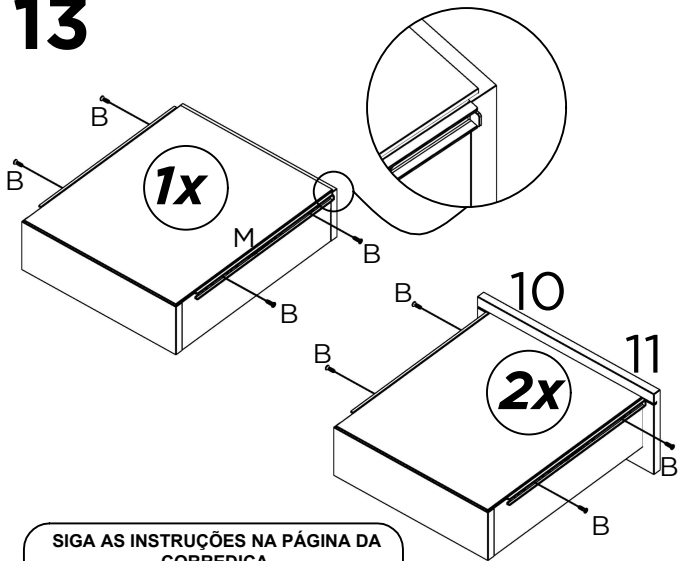

SIGA AS INSTRUÇÕES NA PÁGINA DA CORREDEIRA.
 FOLLOW THE INSTRUCTIONS ON THE SLIDE PAGE.
 SIGA LAS INSTRUCCIONES EN LA PÁGINA DE LA CORREDERA.

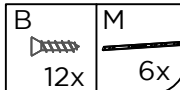

14

3x

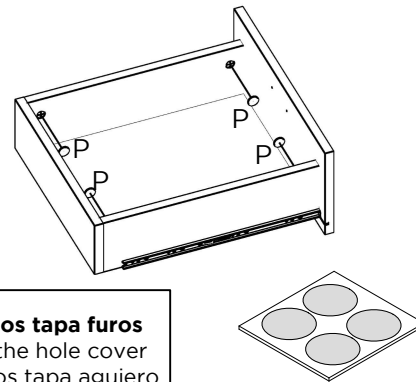

Cole os tapa furos
 Glue the hole cover
 Pega los tapa agujero

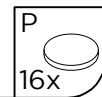

15

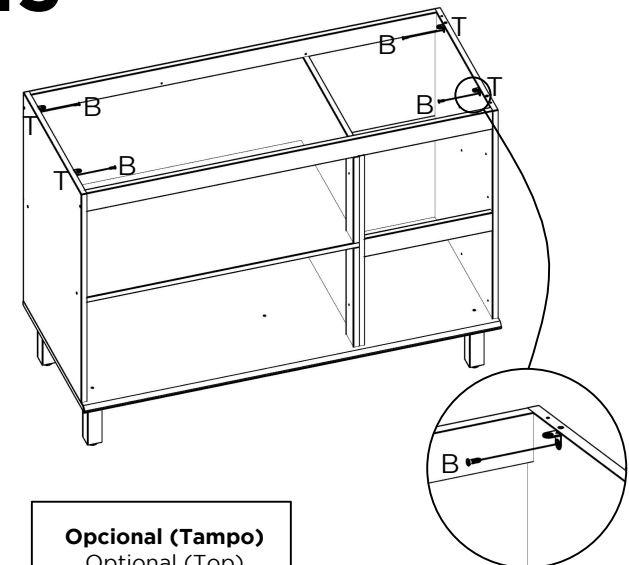

Opcional (Tampo)
 Optional (Top)
 Opcional (Tablero)

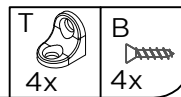

16

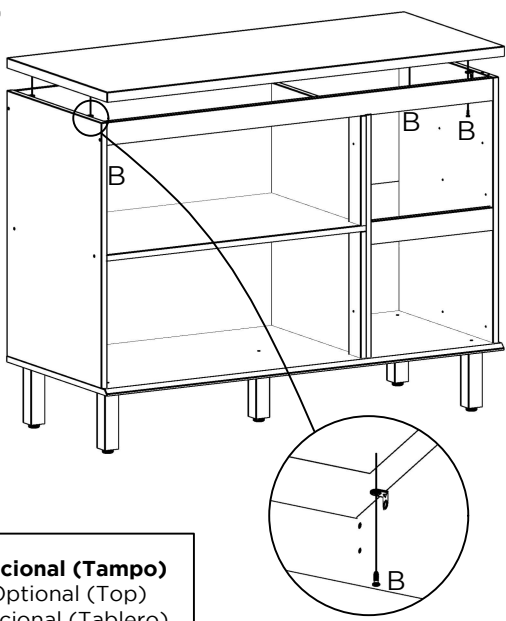

Opcional (Tampo)
 Optional (Top)
 Opcional (Tablero)



17

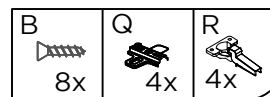
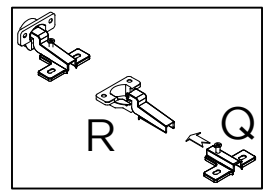
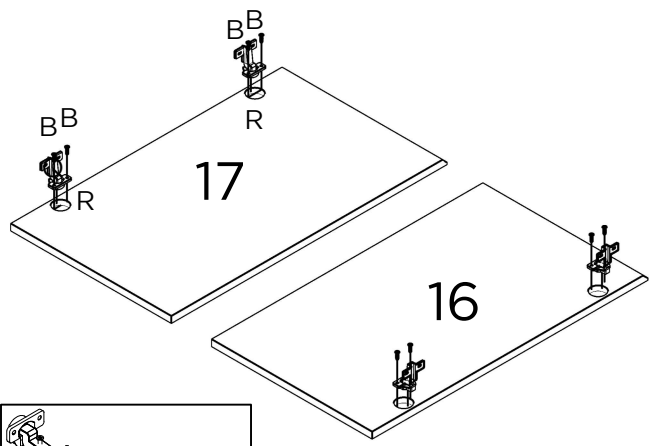

18

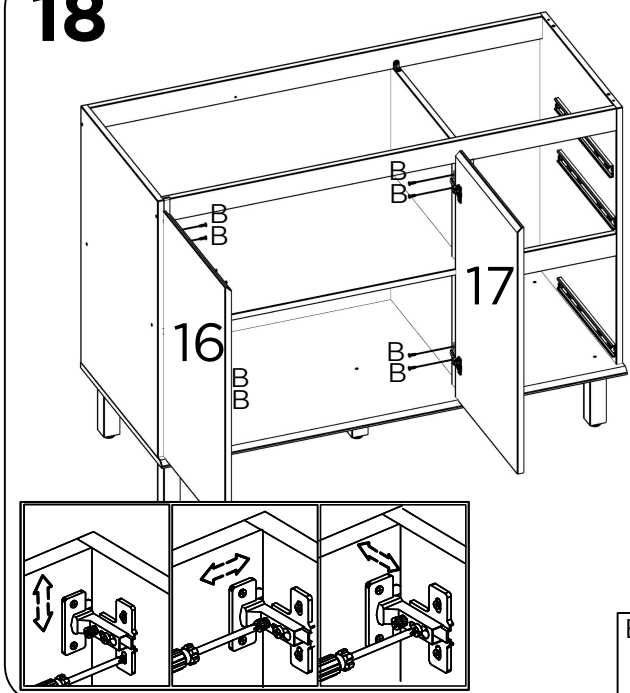

19

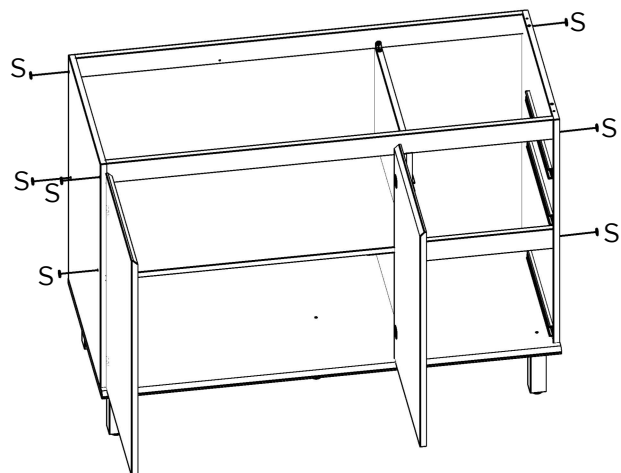

Cole os tapa furos
Glue the hole cover
Pega los tapa agujero



20

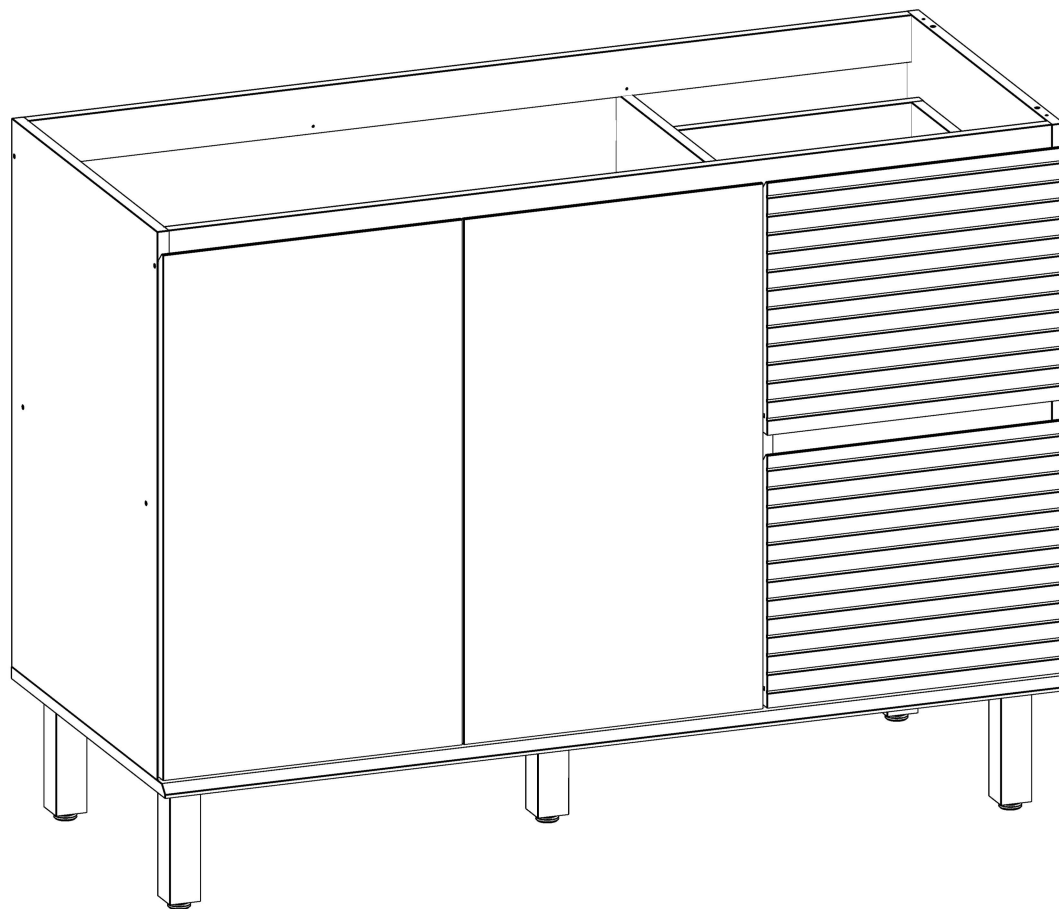
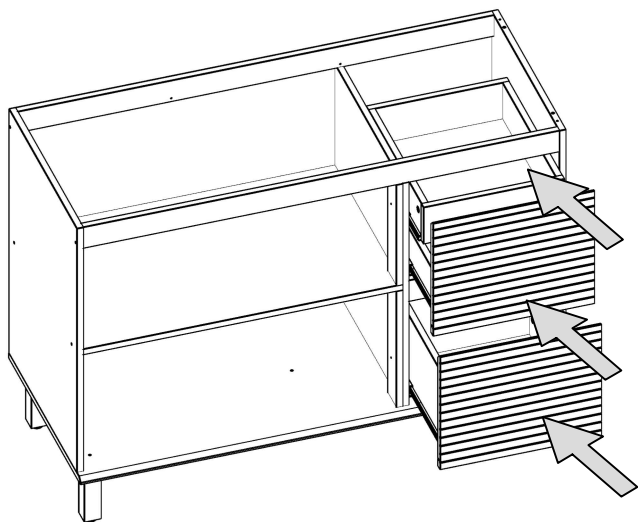

MANUAL DE MONTAGEM / ASSEMBLY INSTRUCTIONS / PLANO DE ARMADO

Antes de montar o móvel, leia com atenção o manual de montagem!
Before assembling the furniture, carefully read the assembly instructions!
Antes de armar el mueble, lea con atención el manual de ensamble!

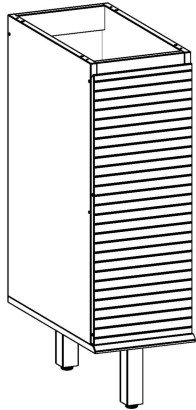

Ref.: 1552

geniaflex
ambientes incríveis para todos

Parabéns! Você comprou um produto de excelente qualidade, fabricado com chapa de madeira de MDP ou MDF, extraída de florestas renováveis. Possui alta resistência e design atual.

Congratulations! You have purchased a product of excellent quality, made from MDP or MDF wood veneer, extracted from renewable forests. It has high strength and current design.

Felicitaciones! Usted compró a un producto de excelente calidad, fabricado con placa de madera de MDP o MDF, proveniente de florestas renovables. Tiene alta resistencia y diseño actual.



ATENÇÃO
ATTENTION
ATENCIÓN

1) Verifique todas as peças antes de começar a montagem.

Check all parts before starting assembly.

Verifique todas las partes antes de empezar el armado.

2) Ao começar a montagem, não apoie as peças na parede.

When starting the assembly, do not support the parts on the wall.

Al empezar el armado, no apoyes las partes en la pared.

3) Ao colocar as peças e ferragens de lado, cuidado para não perde-las.

When placing parts and hardware aside, be careful not to lose them.

Al poner las piezas y herrages a parte, cuidado para no dañarlas.

4) O móvel deve ser montado no chão, para isso, use a própria caixa para proteger e não danificar o piso.

The furniture must be mounted on the floor, to do this, use the box itself to protect and not damage the floor.

El mueble suele ser armado al piso, para eso, use la propia caja para protegerlo y no dañar al piso.

5) Comece a montagem seguindo as instruções passo a passo.

Begin assembly by following the step-by-step instructions.

Comience el armado siguiendo la instrucciones paso a paso.

6) É de responsabilidade do montador seguir as intruções desse manual, que são fundamentais para a estrutura do móvel.

It's the assembler's responsibility to follow the instructions in this manual, which are fundamental to the structure of the furniture.

Es de responsabilidad del armador seguir las instrucciones de este manual, que son fundamentales para la estructura del mueble.

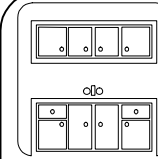

CUIDADOS
CARE
CUIDADO

1) A conservação e limpeza deve ser feita com um pano levemente umedecido com água.

Care and cleaning should be done with a cloth slightly moistened with water.

La conservación y limpieza debe ser hecha con un trapo levemente humedecido en agua.

2) Não use produtos abrasivos, como saponáceo, detergentes e esponja de aço.

Do not use abrasive products, such as soap, detergents and steel sponge.

No use productos abrasivos, como saponáceo, detergentes y esponja de acero.

3) Não use cera ou óleo para dar brilho ao móvel.

Do not use wax or oil to shine the furniture.

No use cera o aceites para darle brillo al mueble.

4) Não expor o móvel a interperies e nem ao calor excessivo.

Do not expose the furniture to weather or excessive heat.

No exponer el mueble a interperies ni al calor excesivo.

5) Ao terminar a montagem, limpe o ambiente e o móvel.

When the assembly is finished, clean the room and the furniture.

Al terminar el armado, limpie al ambiente y al mueble.

FERRAMENTAS / TOOLS / HERRAMIENTAS



MARTELO
HAMMER
MARTILLO



MARTELO DE BORRACHA
RUBBER HAMMER
MARTILLO GOMA



CHAVE PHILLIPS
PHILLIPS SCREWDRIVER
LLAVE PHILLIPS



TRENA
MEASURING TAPE
CINTA MÉTRICA









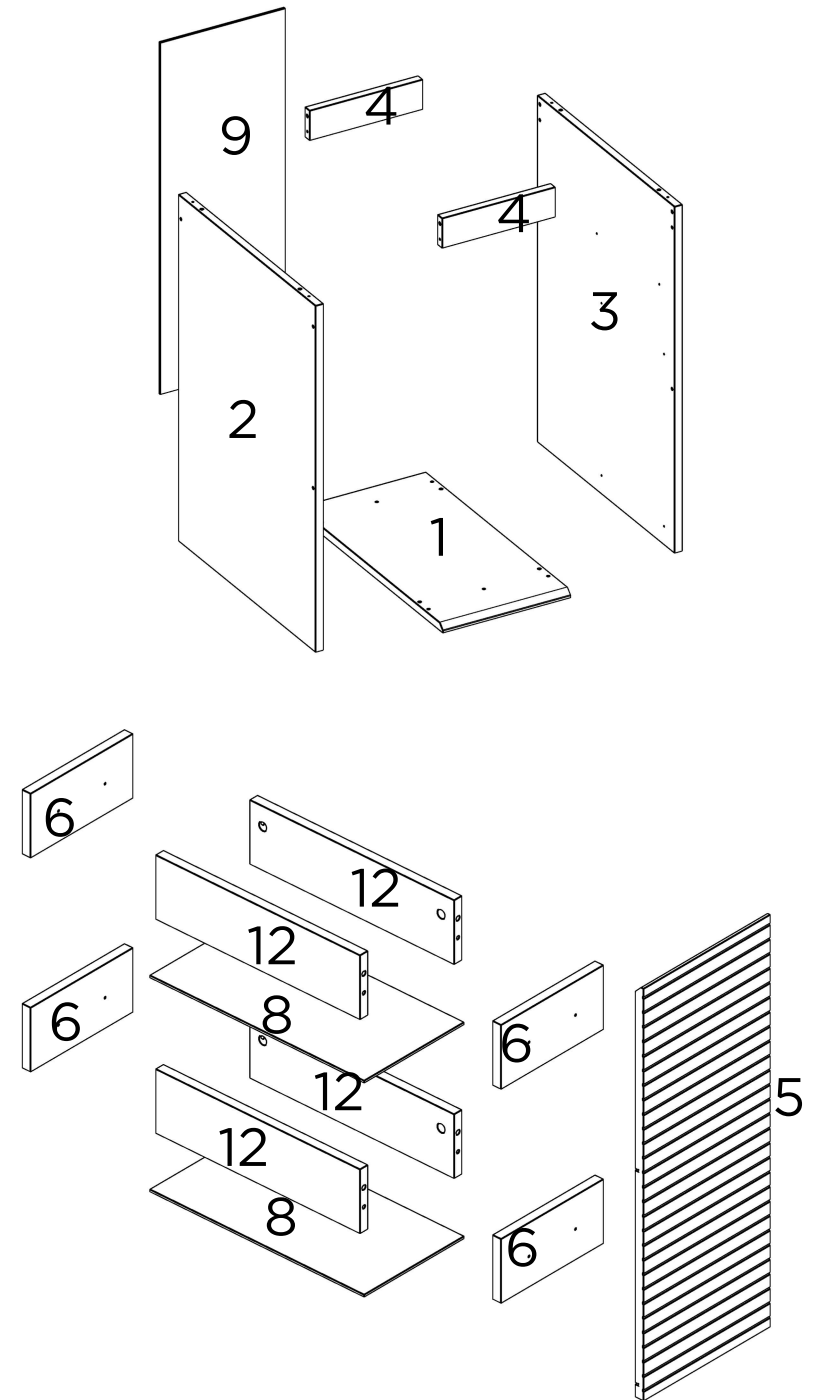



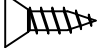

PARAFUSADEIRA
DRILL/ELETRIC
SCREWDRIVER
DESTORNILLADOR
ELÉCTRICO

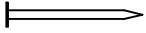
PEÇAS / PARTS / PIEZAS

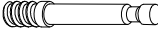
Nº No Num	DESCRIÇÃO DESCRIPTION DESCRIPCIÓN	QTD QTY CANT
1	BASE 45 GRAUS - 45 DEGREES BOTTOM - BASE 45 GRADOS	1
2	LATERAL ESQUERDA - LEFT SIDE PANEL LATERAL IZQUIERDA	1
3	LATERAL DIREITA - RIGHT SIDE PANEL LATERAL DERECHO	1
4	TRAVESSA FRONTAL/TRASEIRA - FRONTAL/BACK PLATE TRAVESAÑO FRONTAL/TRASERO	2
5	FRENTE DE GAVETA DUPLA 45 GRAUS - DOUBLE DRAWER FRONT 45 DEGREES FRONTAL DE DOBLE CAJÓN 45 GRADOS	1
6	COSTA DE GAVETA - DRAWER BACK TRASERO DEL CAJÓN	4
8	FUNDO DE GAVETA - DRAWER BOTTOM PANEL FONDO DEL CAJÓN	2
9	COSTA - BACK PANEL TRASERO	1
12	LATERAL DE GAVETA - DRAWER SIDE LATERAL DEL CAJÓN	4



FERRAGENS / HARDWARE / HERRAJES

CÓD CODE COD	DESCRIÇÃO DESCRIPTION DESCRIPCIÓN	QTD QTY CANT
A	 CAVILHA WOODEN DOWEL TARUGO	16
B	 PARAFUSO 3,5X14mm SCREW 3,5X14mm TORNILLO 4X12mm	32
C	 CORREDEÇA LATERAL SIDE SLIDE CORREDERA LATERAL	2
D	 PARAFUSO 5X50mm SCREW 5X50mm TORNILLO 5X50mm	2
E	 PÉ LEG PATA	2
F	 PARAFUSO 3,5X40mm SCREW 3,5X40mm TORNILLO 3,5X40mm	8
G	 PARAFUSO 3,5X25mm SCREW 3,5X25mm TORNILLO 3,5X25mm	3
H	 PREGO NAIL CLAVO	20
i	 PARAFUSO 4X25mm SCREW 4X25mm TORNILLO 4X25mm	4
J	 PARAFUSO MINIFIX MINIFIX SCREW TORNILLO MINIFIX	8
K	 TAMBOR MINIFIX MINIFIX DRUM TAMBOR MINIFIX	8
L	 PREGO ANELADO RINGED NAIL CLAVO ANILLADO	30
M	 CORREDEÇA GAVETA DRAWER SLIDE CORREDERA DEL CAJÓN	2
P	 TAPA-FURO MAIOR BIGGER HOLE COVER TAPA AGUJERO MAYOR	8
Q	 CANTONEIRA DE 2 FUROS METALLIC ANGLE CANTONERA 2 AGUJEROS	8
R	 TAPA-FURO MENOR SMALL HOLE COVER TAPA AGUJERO MENOR	8

UTILIZE A RÉGUA PARA IDENTIFICAR OS PARAFUSOS
USE THE RULER TO IDENTIFY THE SCREWS
UTILICE LA REGLA PARA IDENTIFICAR LOS TORNILLOS



PESO SUPORTADO / WEIGHT SUPPORTED / PESO SOPORTADO

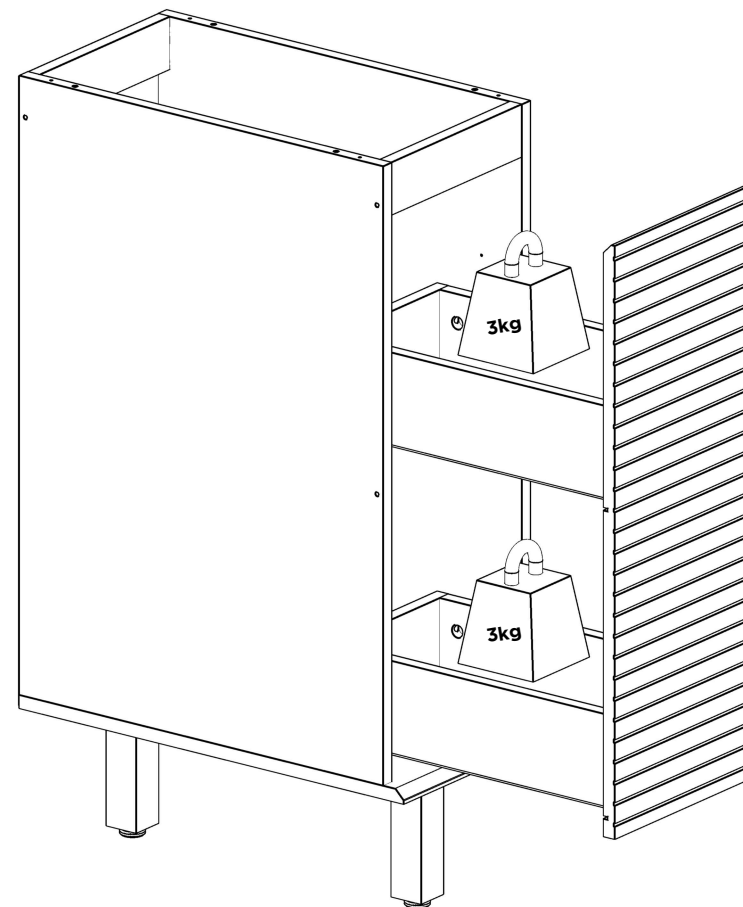

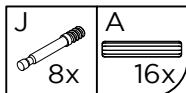
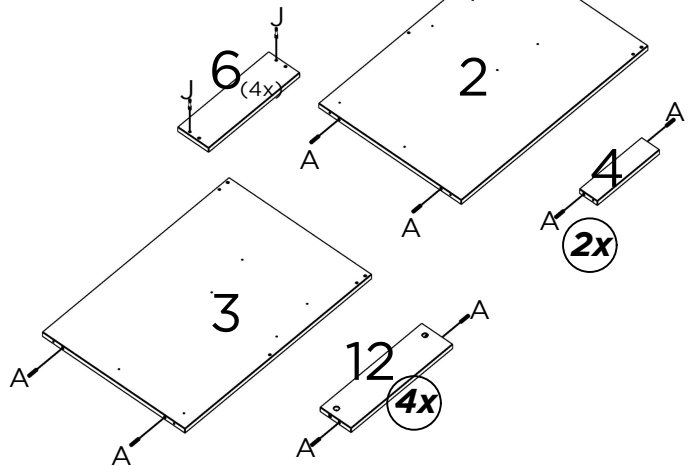
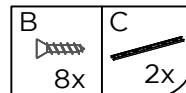
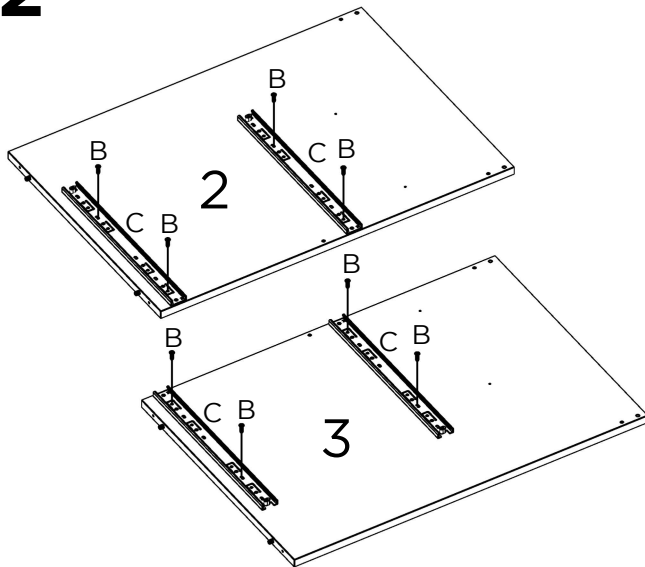
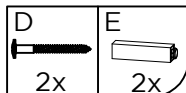
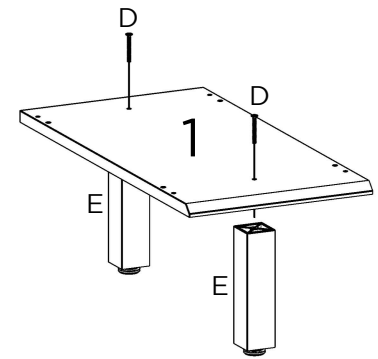
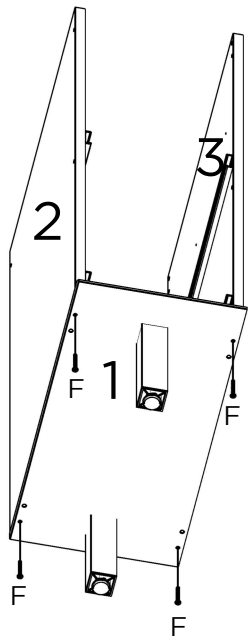
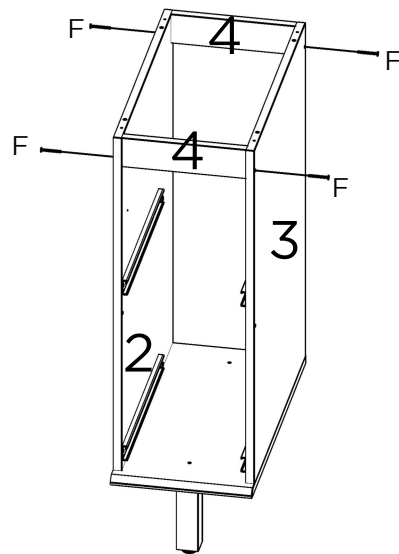
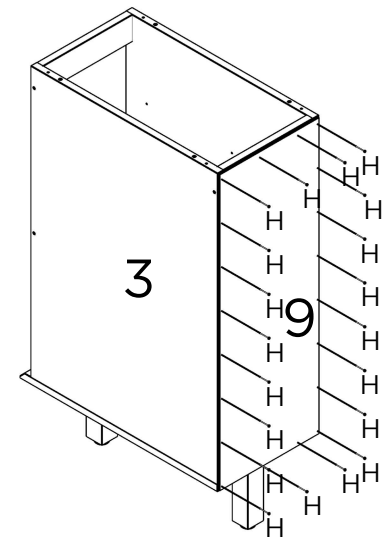
1**2****3****4****5****6**

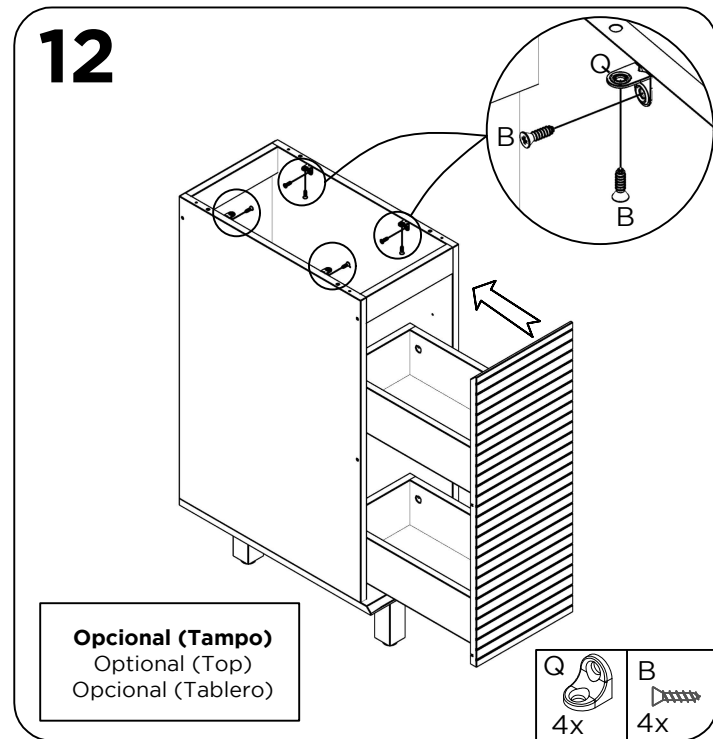
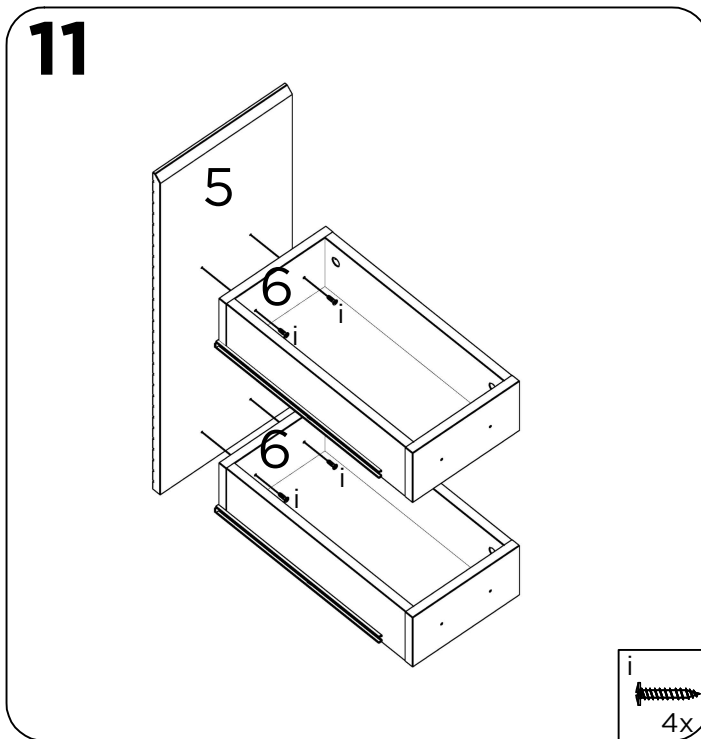
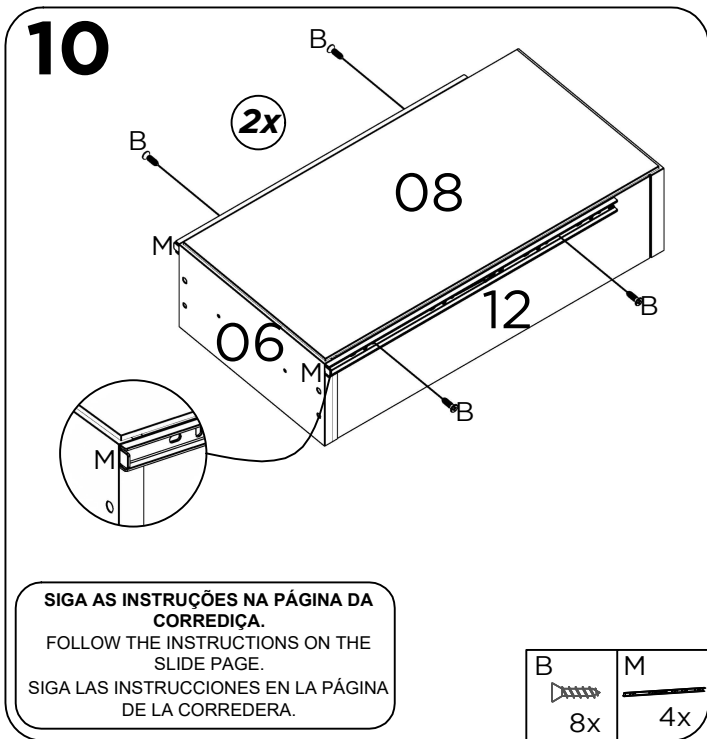
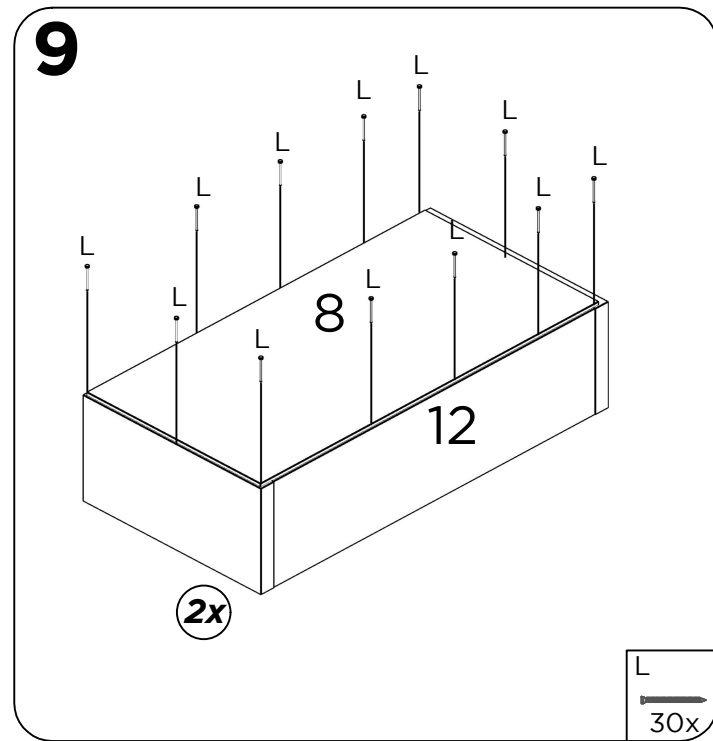
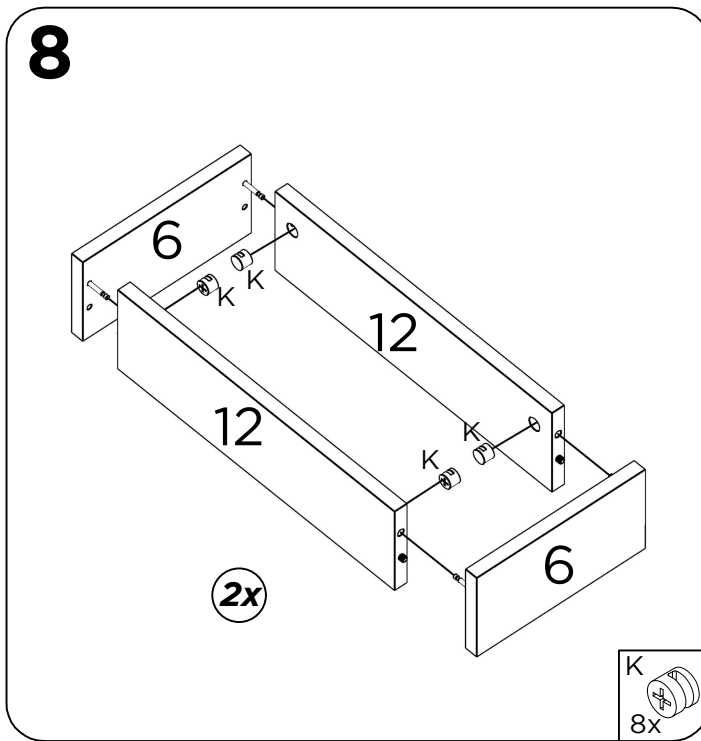
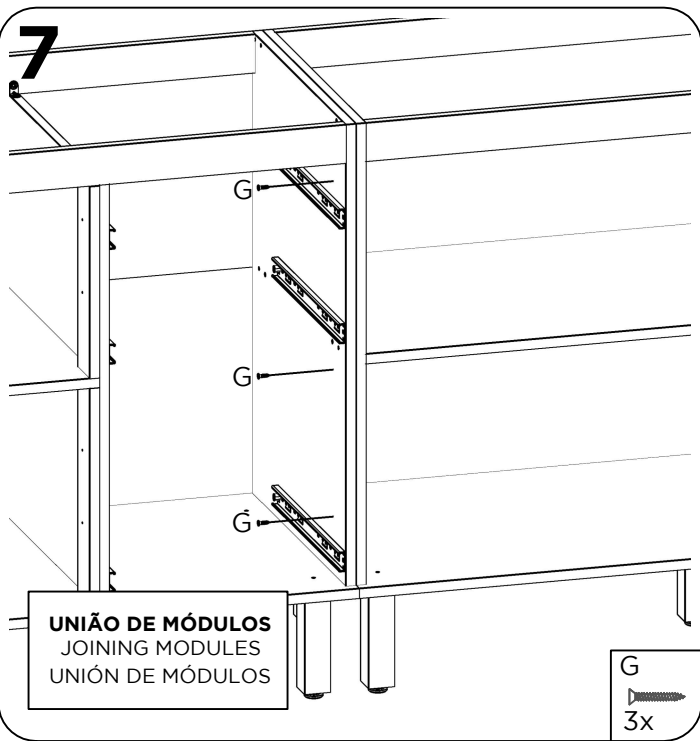

Para instalar as corredeças telescópicas é necessário seguir os passos, separando as partes que compõem a corredeça.

To install the telescopic slides, it is necessary to follow the steps, separating the parts that make up the slide.

Para instalar las correderas telescópicas es necesario seguir los pasos, separando las dos partes que componen la pieza.

Corredeça telescópica / Telescopic slides Corredera telescópica



Passo 1 / Step 1 / Paso 1

Corredeça telescópica aberta / Telescopic slide open / Corredera telescópica abierta

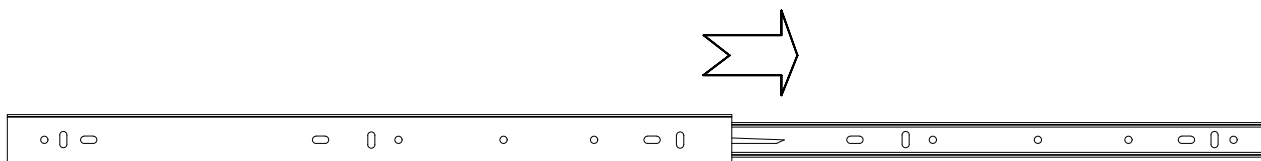

Para separar as partes da corredeça, puxe o engate que está na parte traseira da corredeça (desenho ao lado) no sentido anti-horário, separando as duas partes, para facilitar a fixação no móvel.

To separate the parts of the slide, pull the hook on the back of the slide (illustration on the side) counterclockwise, separating the two parts, to facilitate attachment to the furniture.

Para separar las dos partes de la corredera, tire el engate que está en la parte de atrás de la corredera (dibujo al lado) en el sentido anti-horario, separando las dos partes, para facilitar la fijación en el mueble.

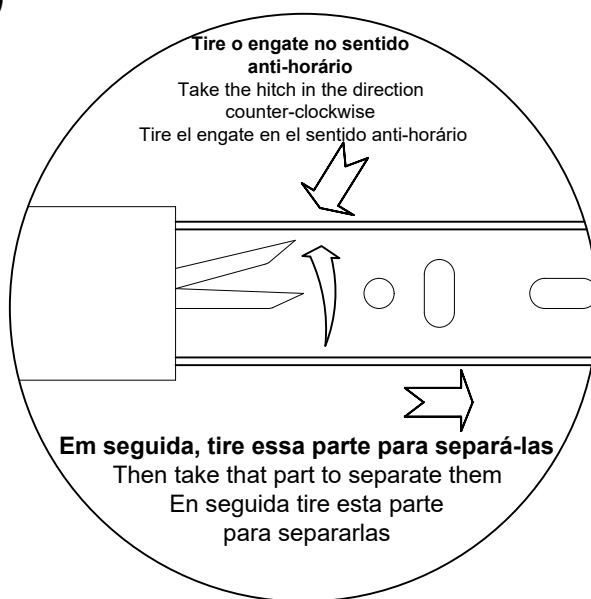
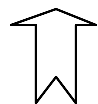

Passo 2 / Step 2 / Paso 2

Com as partes da corredeça separadas, fixar-las no móvel.

With the slide parts separated, fix them to the furniture.

Con las partes de la corredera separadas, fijarlas en el mueble.

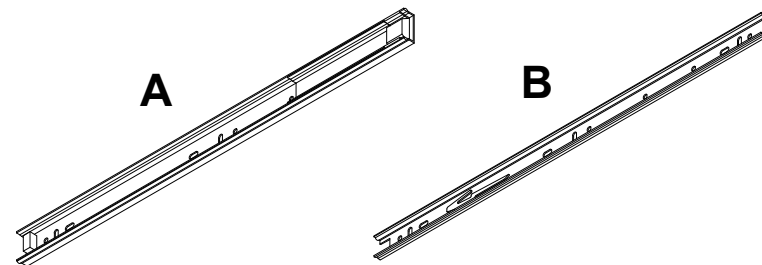

As corredeças devem ficar alinhadas com a parte inferior das laterais de gavetas.

The slide should be flush with the underside of the drawer sides.

Las correderas deben quedar aliñada con la parte inferior de las laterales de los cajones.

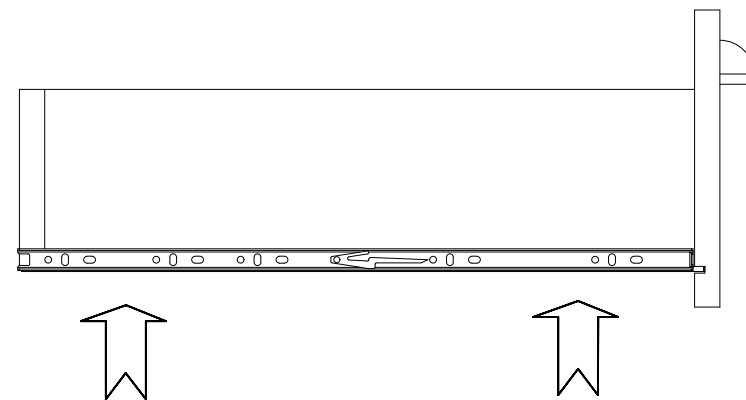

MANUAL DE MONTAGEM / ASSEMBLY INSTRUCTIONS / PLANO DE ARMADO

Antes de montar o móvel, leia com atenção o manual de montagem!
Before assembling the furniture, carefully read the assembly instructions!
Antes de armar el mueble, lea con atención el manual de ensamble!

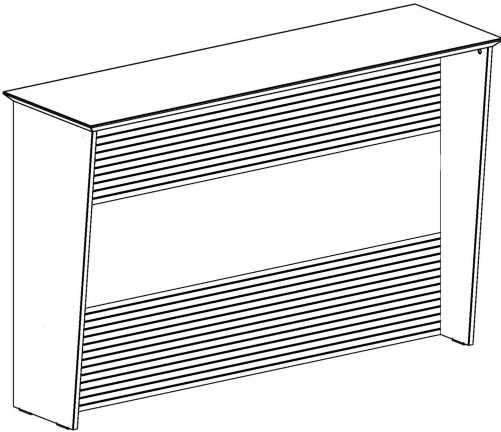

Ref.: 1553

genialflex
ambientes incríveis para todos

Parabéns! Você comprou um produto de excelente qualidade, fabricado com chapa de madeira de MDP ou MDF, extraída de florestas renováveis. Possui alta resistência e design atual.

Congratulations! You have purchased a product of excellent quality, made from MDP or MDF wood veneer, extracted from renewable forests. It has high strength and current design.

Felicitaciones! Usted compró a un producto de excelente calidad, fabricado con placa de madera de MDP o MDF, proveniente de florestas renovables. Tiene alta resistencia y diseño actual.



ATENÇÃO
ATTENTION
ATENCIÓN

1) Verifique todas as peças antes de começar a montagem.

Check all parts before starting assembly.

Verifique todas las partes antes de empezar el armado.

2) Ao começar a montagem, não apoie as peças na parede.

When starting the assembly, do not support the parts on the wall.

Al empezar el armado, no apoyes las partes en la pared.

3) Ao colocar as peças e ferragens de lado, cuidado para não perde-las.

When placing parts and hardware aside, be careful not to lose them.

Al poner las piezas y herrages a parte, cuidado para no dañarlas.

4) O móvel deve ser montado no chão, para isso, use a própria caixa para proteger e não danificar o piso.

The furniture must be mounted on the floor, to do this, use the box itself to protect and not damage the floor.

El mueble suele ser armado al piso, para eso, use la propia caja para protegerlo y no dañar al piso.

5) Comece a montagem seguindo as instruções passo a passo.

Begin assembly by following the step-by-step instructions.

Comience el armado siguiendo la instrucciones paso a paso.

6) É de responsabilidade do montador seguir as intruções desse manual, que são fundamentais para a estrutura do móvel.

It's the assembler's responsibility to follow the instructions in this manual, which are fundamental to the structure of the furniture.

Es de responsabilidad del armador seguir las instrucciones de este manual, que son fundamentales para la estructura del mueble.

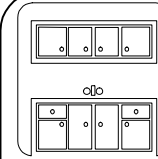

CUIDADOS
CARE
CUIDADO

1) A conservação e limpeza deve ser feita com um pano levemente umedecido com água.

Care and cleaning should be done with a cloth slightly moistened with water.

La conservación y limpieza debe ser hecha con un trapo levemente humedecido en agua.

2) Não use produtos abrasivos, como saponáceo, detergentes e esponja de aço.

Do not use abrasive products, such as soap, detergents and steel sponge.

No use productos abrasivos, como saponáceo, detergentes y esponja de acero.

3) Não use cera ou óleo para dar brilho ao móvel.

Do not use wax or oil to shine the furniture.

No use cera o aceites para darle brillo al mueble.

4) Não expor o móvel a interpéries e nem ao calor excessivo.

Do not expose the furniture to weather or excessive heat.

No exponer el mueble a interperies ni al calor excesivo.

5) Ao terminar a montagem, limpe o ambiente e o móvel.

When the assembly is finished, clean the room and the furniture.

Al terminar el armado, limpie al ambiente y al mueble.

FERRAMENTAS / TOOLS / HERRAMIENTAS



MARTELO
HAMMER
MARTILLO



MARTELO DE BORRACHA
RUBBER HAMMER
MARTILLO GOMA



CHAVE PHILLIPS
PHILLIPS SCREWDRIVER
LLAVE PHILLIPS



TRENA
MEASURING TAPE
CINTA MÉTRICA



PARAFUSADEIRA
DRILL/ELECTRIC
SCREWDRIVER
DESTORNILLADOR
ELÉCTRICO





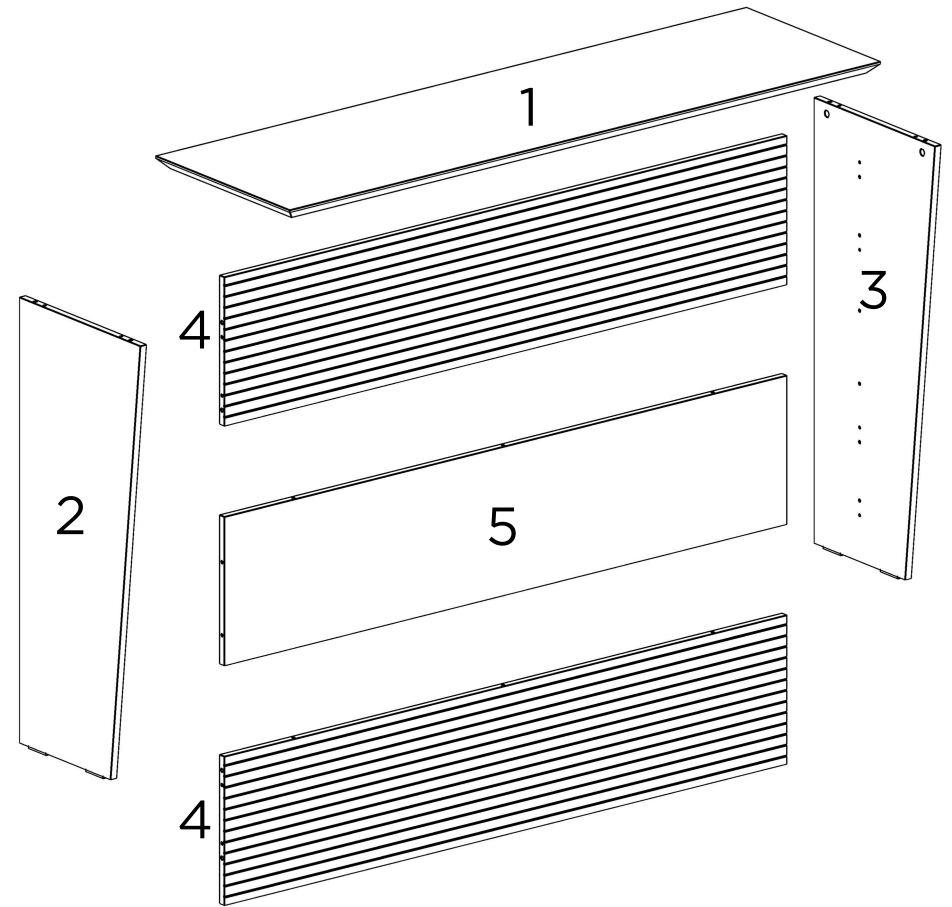



PEÇAS / PARTS / PIEZAS

Nº No Num	DESCRIÇÃO DESCRIPTION DESCRIPCIÓN	QTD QTY CANT
1	TAMPO TOP TABLERO	1
2	LATERAL ESQUERDA LEFT SIDE PANEL LATERAL IZQUIERDA	1
3	LATERAL DIREITA RIGHT SIDE PANEL LATERAL DERECHA	1
4	PAINEL RISCADO SCRATCHED PANEL PANEL RAYADO	2
5	PAINEL PANEL PANEL	1



UTILIZE A RÉGUA PARA IDENTIFICAR OS PARAFUSOS
 USE THE RULER TO IDENTIFY THE SCREWS
 UTILICE LA REGLA PARA IDENTIFICAR LOS TORNILLOS

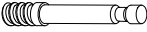

FERRAGENS / HARDWARE / HERRAJES		
CÓD CODE COD	DESCRIÇÃO DESCRIPTION DESCRIPCIÓN	QTD QTY CANT
A	 CAVILHA 6x30 WOODEN DOWEL 6x30 TARUGO 6x30	16
B	 SAPATA PLASTICA PLASTIC SHOE PROTECIÓN DE PLASTICO	4
C	 CAVILHA 6x40 WOODEN DOWEL 6x40 TARUGO 6x40	6
G	 PARAFUSO 4X14mm SCREW 4X14mm TORNILLO 4X14mm	12
H	 CANTONEIRA DE 2 FUROS METALLIC ANGLE CANTONERA 2 AGUJEROS	6
M	 TAPA-FURO MAIOR BIGGER HOLE COVER TAPA AGUJERO MAJOR	16
Q	 PARAFUSO MINIFIX MINIFIX SCREW TORNILLO MINIFIX	16
R	 TAMBOR MINIFIX MINIFIX DRUM TAMBOR MINIFIX	16

PESO SUPORTADO / WEIGHT SUPPORTED / PESO SOPORTADO

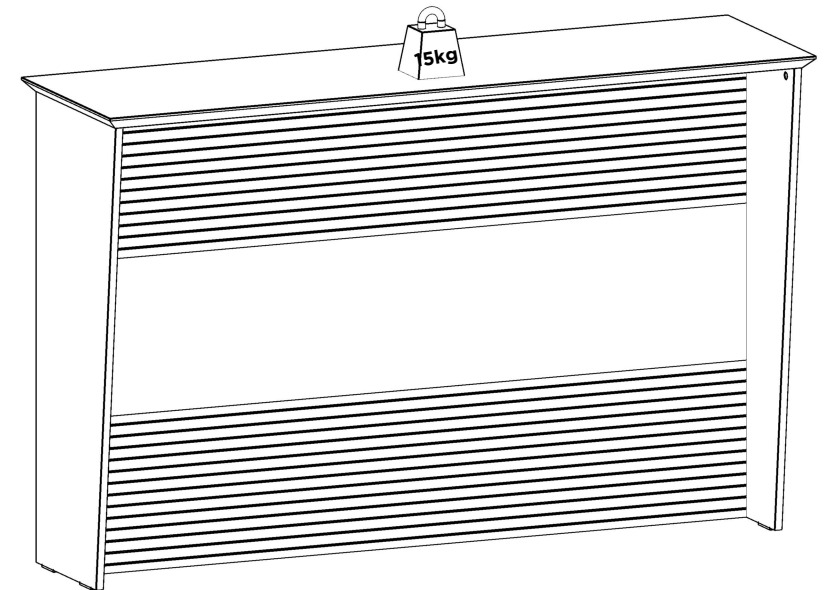

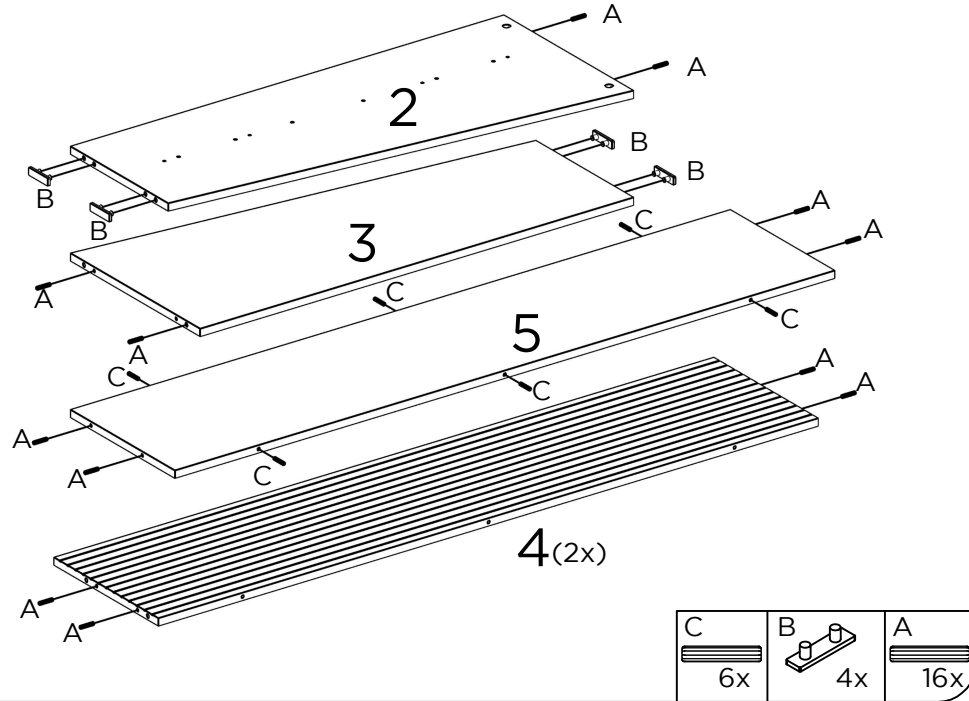
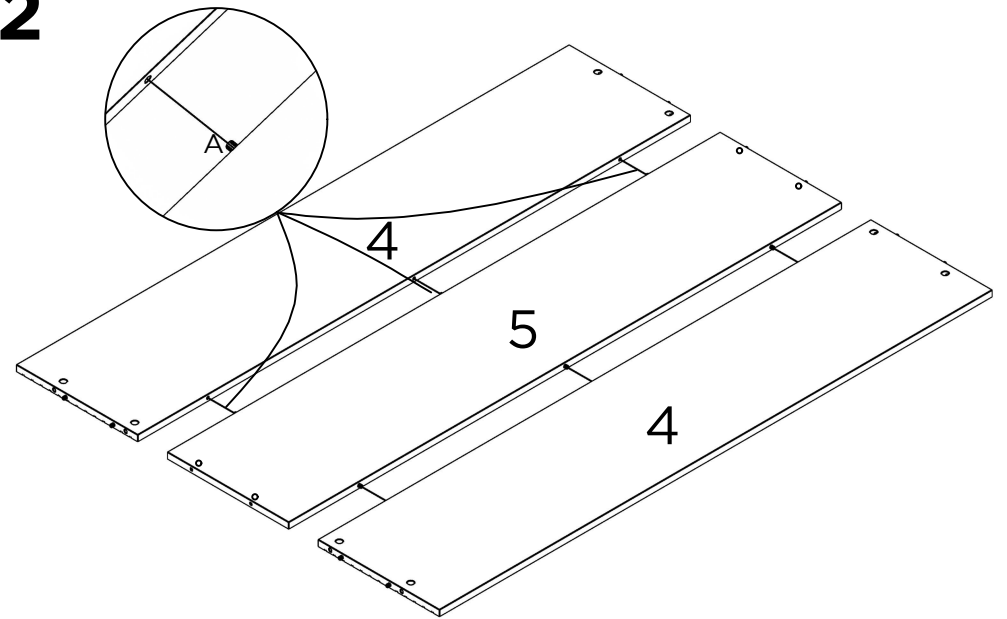
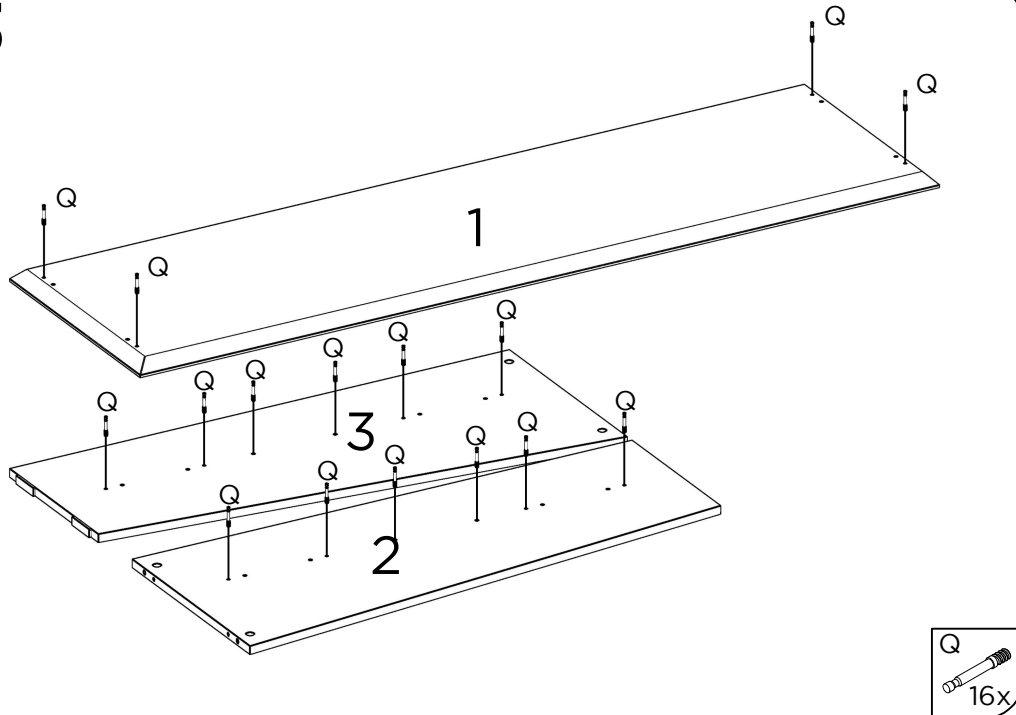
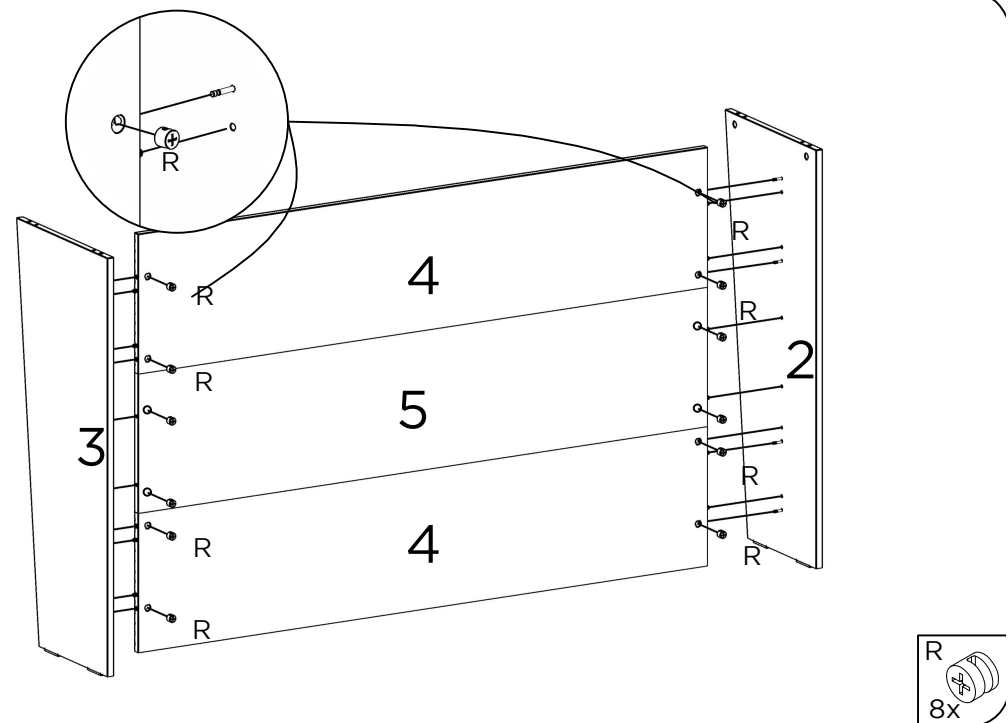
1**2****3****4**R
8x

5

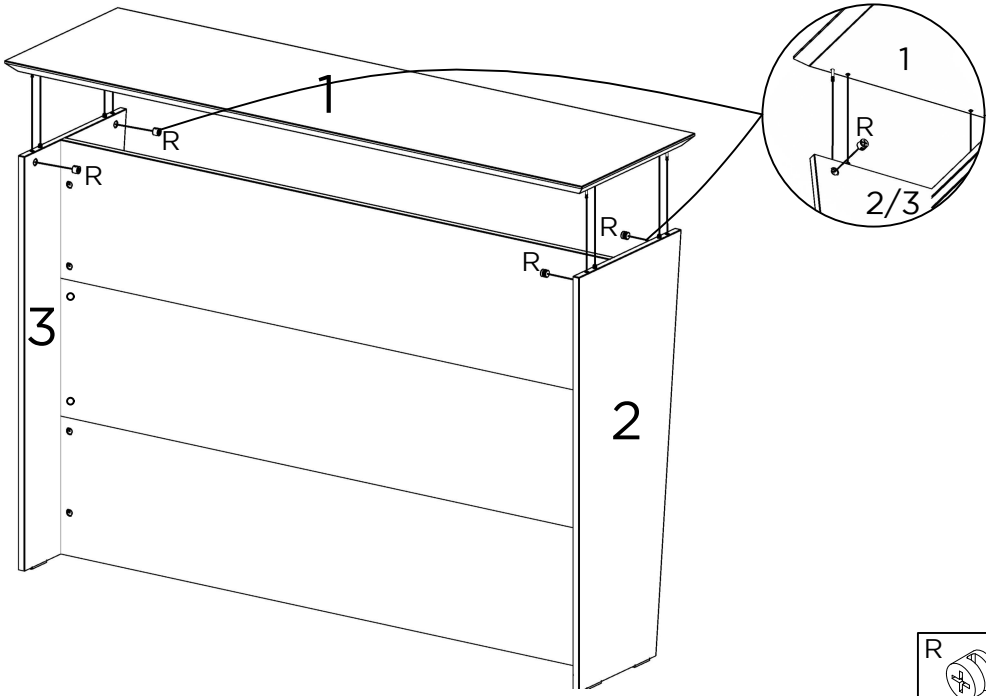

R
4x

6

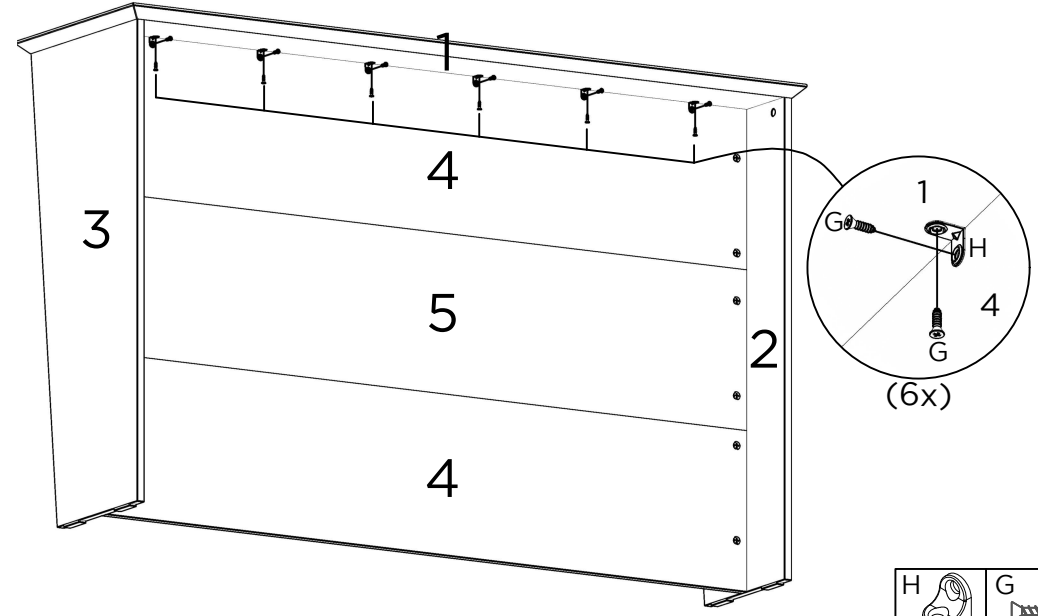

H G
6x 12x

7

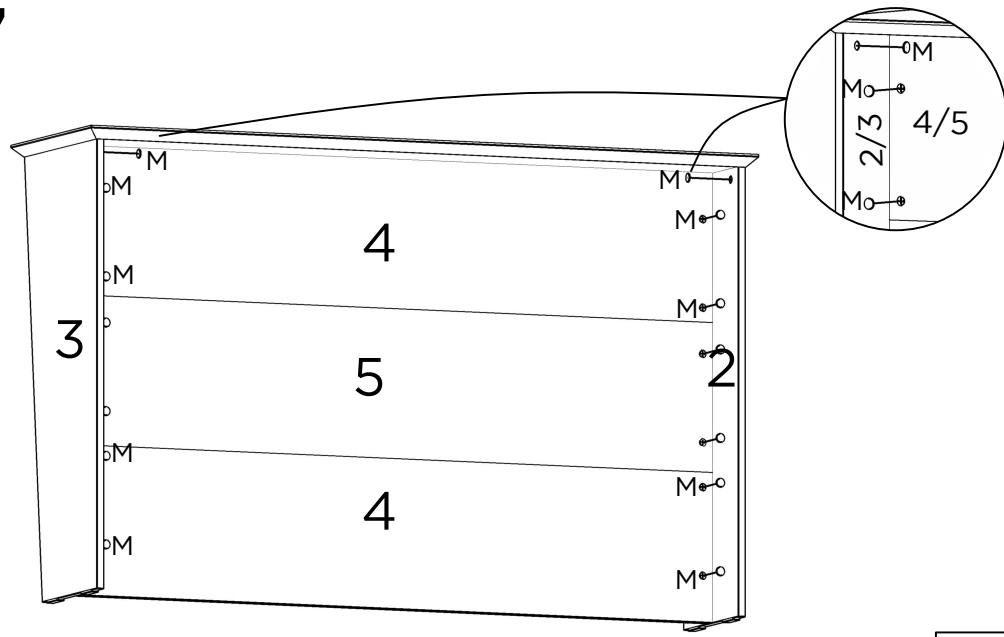

M
12x

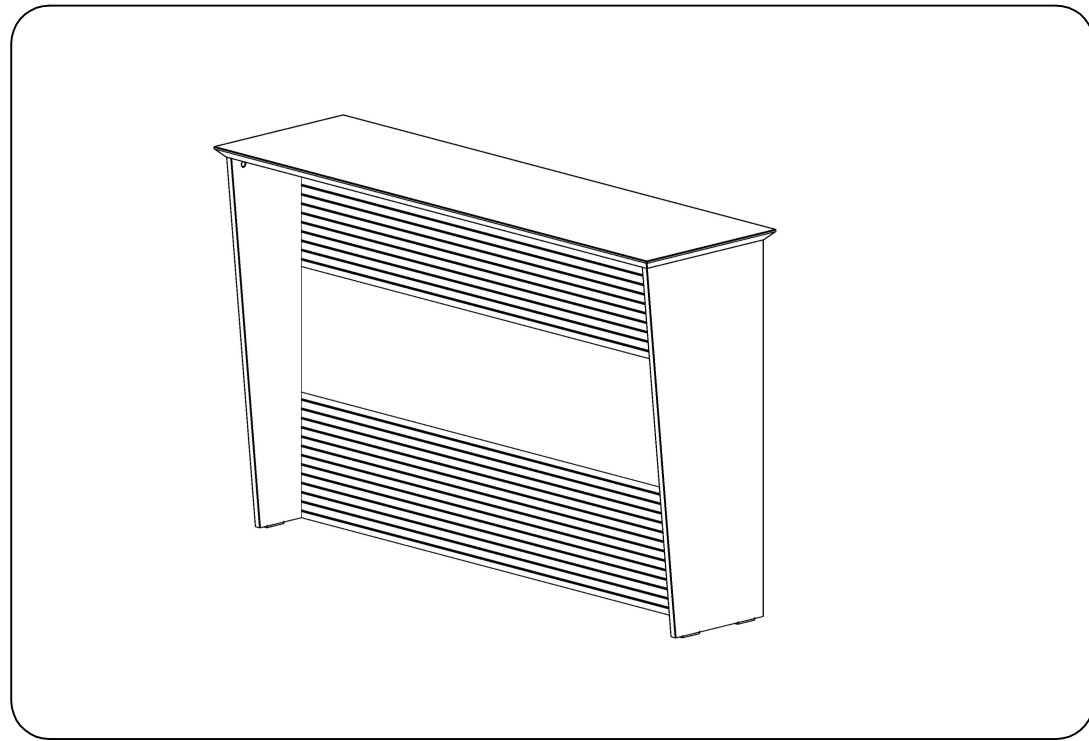

Agora que você já comprou o seu móvel, ele merece ser montado do jeito certo.

Erros de montagem causam mais de **60%** dos danos em móveis.

Por que contratar?

Tranquilidade do **início ao fim** da montagem



PROFISSIONAIS QUALIFICADOS

Especialistas certificados na **MadeiraMadeira Serviços**.



FERRAMENTAS PROFISSIONAIS

que **protegem** seus móveis.



AGENDAMENTO EM 24 HORAS

escolha a data e o turno **ideais para** você.



GARANTIA DE 3 MESES

de cobertura **completa**.

Mais de 1 MILHÃO DE MONTAGENS
★ com avaliação 4.7 ★

Mariana S., São Paulo

"Chegaram no horário e montaram tudo rapidamente. Serviço incrível!"



Carlos R., Belo Horizonte

"Tentei montar sozinho e foi um desastre. Com a **MadeiraMadeira Serviços** ficou perfeito."



Ana P., Rio de Janeiro

"Agendamento ágil e **montagem pontual e perfeita**. Recomendo demais!"



Agende agora pelo QR Code

Madeira**Madeira** Serviços · Atendimento em todo o Brasil



Escaneie o QRCode