

# MANUAL DE MONTAGEM / ASSEMBLY INSTRUCTIONS / PLANO DE ARMADO

**Antes de montar o móvel, leia com atenção o manual de montagem!**  
**Before assembling the furniture, carefully read the assembly instructions!**  
**Antes de armar el mueble, lea con atención el manual de ensamble!**

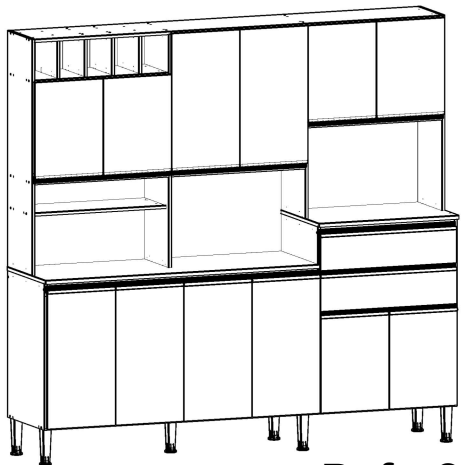

**Ref.: 0338**

**genialflex**  
ambientes incríveis para todos

Parabéns! Você comprou um produto de excelente qualidade, fabricado com chapa de madeira de MDP ou MDF, extraída de florestas renováveis. Possui alta resistência e design atual.

Congratulations! You have purchased a product of excellent quality, made from MDP or MDF wood veneer, extracted from renewable forests. It has high strength and current design.

Felicitaciones! Usted compró a un producto de excelente calidad, fabricado con placa de madera de MDP o MDF, proveniente de florestas renovables. Tiene alta resistencia y diseño actual.



**ATENÇÃO**  
**ATTENTION**  
**ATENCIÓN**

- 1) Verifique todas as peças antes de começar a montagem.**  
Check all parts before starting assembly.  
Verifique todas las partes antes de empezar el armado.
- 2) Ao começar a montagem, não apoie as peças na parede.**  
When starting the assembly, do not support the parts on the wall.  
Al empezar el armado, no apoyes las partes en la pared.
- 3) Ao colocar as peças e ferragens de lado, cuidado para não perde-las.**  
When placing parts and hardware aside, be careful not to lose them.  
Al poner las piezas y herrages a parte, cuidado para no dañarlas.
- 4) O móvel deve ser montado no chão, para isso, use a própria caixa para proteger e não danificar o piso.**  
The furniture must be mounted on the floor, to do this, use the box itself to protect and not damage the floor.  
El mueble suele ser armado al piso, para eso, use la propia caja para protegerlo y no dañar al piso.

- 5) Comece a montagem seguindo as instruções passo a passo.**  
Begin assembly by following the step-by-step instructions.  
Comience el armado siguiendo la instrucciones paso a paso.

- 6) É de responsabilidade do montador seguir as intruções desse manual, que são fundamentais para a estrutura do móvel.**  
It's the assembler's responsibility to follow the instructions in this manual, which are fundamental to the structure of the furniture.  
Es de responsabilidad del armador seguir las instrucciones de este manual, que son fundamentales para la estructura del mueble.

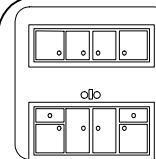

**CUIDADOS**  
**CARE**  
**CUIDADO**

- 1) A conservação e limpeza deve ser feita com um pano levemente umedecido com água.**  
Care and cleaning should be done with a cloth slightly moistened with water.  
La conservación y limpieza debe ser hecha con un trapo levemente humedecido en agua.
- 2) Não use produtos abrasivos, como saponáceo, detergentes e esponja de aço.**  
Do not use abrasive products, such as soap, detergents and steel sponge.  
No use productos abrasivos, como saponáceo, detergentes y esponja de acero.
- 3) Não use cera ou óleo para dar brilho ao móvel.**  
Do not use wax or oil to shine the furniture.  
No use cera o aceites para darle brillo al mueble.
- 4) Não expor o móvel a intempéries e nem ao calor excessivo.**  
Do not expose the furniture to weather or excessive heat.  
No exponer el mueble a interperies ni al calor excesivo.
- 5) Ao terminar a montagem, limpe o ambiente e o móvel.**  
When the assembly is finished, clean the room and the furniture.  
Al terminar el armado, limpie al ambiente y al mueble.

## FERRAMENTAS / TOOLS / HERRAMIENTAS



MARTELO  
HAMMER  
MARTILLO



CHAVE PHILLIPS  
PHILLIPS SCREWDRIVER  
LLAVE PHILLIPS



NAO RECOMENDAVEL  
NOT ADVISABLE  
NO RECOMENDABLE



MARTELO DE BORRACHA  
RUBBER HAMMER  
MARTILLO GOMA









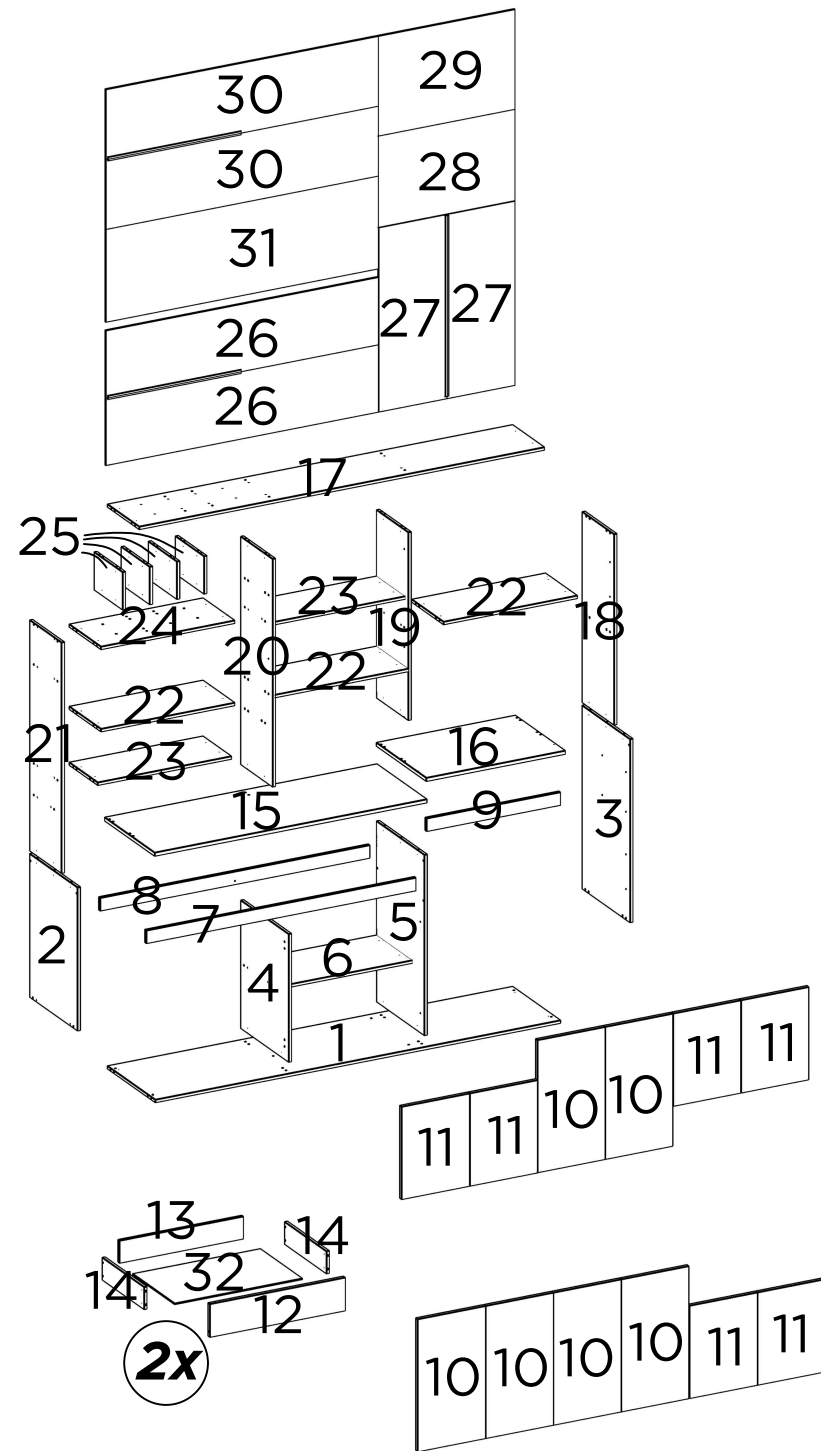











TRENA  
MEASURING TAP  
CINTA MÉTRICA

**PEÇAS / PARTS / PIEZAS**

Nº No Num	DESCRIÇÃO DESCRIPTION DESCRIPCIÓN	QTD QTY CANT
1	BASE / BOTTOM / BASE	1
2	LATERAL ESQUERDA / LEFT SIDE PANEL / LATERAL IZQUIERDA	1
3	LATERAL DIREITA / RIGHT SIDE PANEL / LATERAL DERECHA	1
4	DIVISÓRIA ESQ INF / LOWER LEFT DIVISION / DIVISIÓN IZQ INF	1
5	DIVISÓRIA DIR INF / LOWER RIGHT DIVISION / DIVISIÓN DER INF	1
6	PRATELEIRA INF / LOWER PLATE PANEL / REPISA INF	1
7	TRAVESSA FRONTAL MAIOR / BIGGER FRONTAL PLATE / TRAVESAÑO FRONTAL MAIOR	1
8	TRAVESSA TRASEIRA / BACK PLATE / TRAVESAÑO TRASERO	1
9	TRAVESSA FRONTAL MENOR / SMALLER FRONTAL PLATE / TRAVESAÑO FRONTAL MENOR	1
10	PORTA MAIOR / BIGGER DOOR / PUERTA MAIOR	6
11	PORTA MENOR / SMALLER DOOR / PUERTA MENOR	6
12	FRENTE DE GAVETA / DRAWER FRONT / FRENTE DEL CAJÓN	2
13	COSTA DE GAVETA / DRAWER BACK / TRASERO DEL CAJÓN	2
14	LATERAL DE GAVETA / DRAWER SIDE / LATERAL DEL CAJÓN	4
15	TAMPO MAIOR / BIGGER TOP PLATE / TABLERO MAIOR	1
16	TAMPO MENOR / SMALLER TOP PLATE / TABLERO MENOR	1
17	TAMPO SUPERIOR / TOP / TABLERO SUPERIOR	1
18	LATERAL SUP DIR / UPPER RIGHT SIDE / LATERAL SUP DERECHA	1
19	DIVISÓRIA SUP DIREITA / UPPER RIGHT DIVISION / DIVISIÓN SUP DERECHA	1
20	DIVISÓRIA SUP ESQUERDA / UPPER LEFT DIVISION / DIVISIÓN SUP IZQUIERDA	1
21	LATERAL SUP ESQUERDA / UPPER LEFT SIDE / LATERAL SUP IZQUIERDA	1
22	PRATELEIRA SUP MAIOR / BIGGER UPPER PLATE PANEL / REPISA SUP MAIOR	3
23	PRATELEIRA SUP MENOR / SMALLER UPPER PLATE PANEL / LATERAL DERECHA	2
24	PRATELEIRA ADEGA / WINE PLATE PANEL / REPISA BODEGA	1
25	DIVISÓRIA ADEGA / WINE DIVISION / DIVISIÓN BODEGA	4
26	COSTA INF MAIOR / BIGGER LOWER BACK PANEL / COSTA BAJA MAIOR	2
27	COSTA INF MENOR / SMALLER LOWER BACK PANEL / COSTA BAJA MENOR	2
28	COSTA NICHU FORNO / NICHE OVEN BACK PANEL / COSTA HORNO NICHU	1
29	COSTA NICHU MENOR / SMALLER NICHE BACK PLATE / COSTA NICHU MENOR	1
30	COSTA SUPERIOR / UPPER BACK PANEL / COSTA SUPERIOR	2
31	COSTA CENTRAL / CENTRAL BACK PANEL / COSTA CENTRAL	1
32	FUNDO DE GAVETA / DRAWER BOTTOM / FUNDO DEL CAJÓN	2

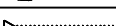

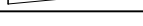
## FERRAGENS / HARDWARE / HERRAJES

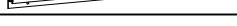
CÓD CODE COD	DESCRIÇÃO DESCRIPTION DESCRIPCIÓN	QTD QTY CANT
A	 CAVILHA 30mm / WOODEN DOWEL 30mm / TARUGO 30mm	69
B	 CAVILHA 50mm / WOODEN DOWEL 50mm / TARUGO 50mm	8
C	 PARAFUSO 4X14mm / SCREW 4X14mm / TORNILLO 4X14mm	190
D	 CORREIÇA LATERAL / SIDE SLIDE / CORREDERA LATERAL	4
E	 PARAFUSO 3,5X40mm / SCREW 3,5X40mm / TORNILLO 3,5X40mm	64
F	 CANTONEIRA DE 4 FUROS / 4 HOLES ANGLE / CANTONERA 4 AGUJEROS	13
G	 CANTONEIRA DE 2 FUROS / 2 HOLES ANGLE / CANTONERA 2 AGUJEROS	2
H	 PARAFUSO 5X50mm / SCREW 5X50mm / TORNILLO 5X50mm	7
I	 PÉ / LEG / PATA	7
J	 PREGO / NAIL / CLAVO	130
K	 GARRA METÁLICA / METALLIC CLAW / GRAB METALICA	35
L	 PERFIL I MENOR / SMALLER PROFILE I / PERFIL I MENOR	2
M	 PERFIL I MAIOR / BIGGER PROFILE I / PERFIL I MAIOR	1
N	 CALÇO PARA DOBRADIÇA / HINGE SHED / CALZO DE BISAGRA	24
O	 DOBRADIÇA / HINGE / BIZAGRA	24
P	 PARAFUSO M4X25 / SCREW M4X25 / TORNILLO M4X25	4
Q	 PORCA M4 / M4 NUT / TUERCA M4	4
R	 PUXADOR MENOR / SMALLER PULLER / TIRADOR MENOR	12
S	 PREGO ANELADO / RINGED NAIL / CLAVO ANILLADO	8
T	 PUXADOR MAIOR / BIGGER PULLER / TIRADOR MAIOR	2
U	 CORREIÇA GAVETA / DRAWER SLIDE / CORREDERA DEL CAJÓN	4

UTILIZE A RÉGUA PARA IDENTIFICAR OS PARAFUSOS  
USE THE RULER TO IDENTIFY THE SCREWS  
UTILICE LA REGLA PARA IDENTIFICAR LOS TORNILLOS



## PESO SUPORTADO / WEIGHT SUPPORTED / PESO SOPORTADO

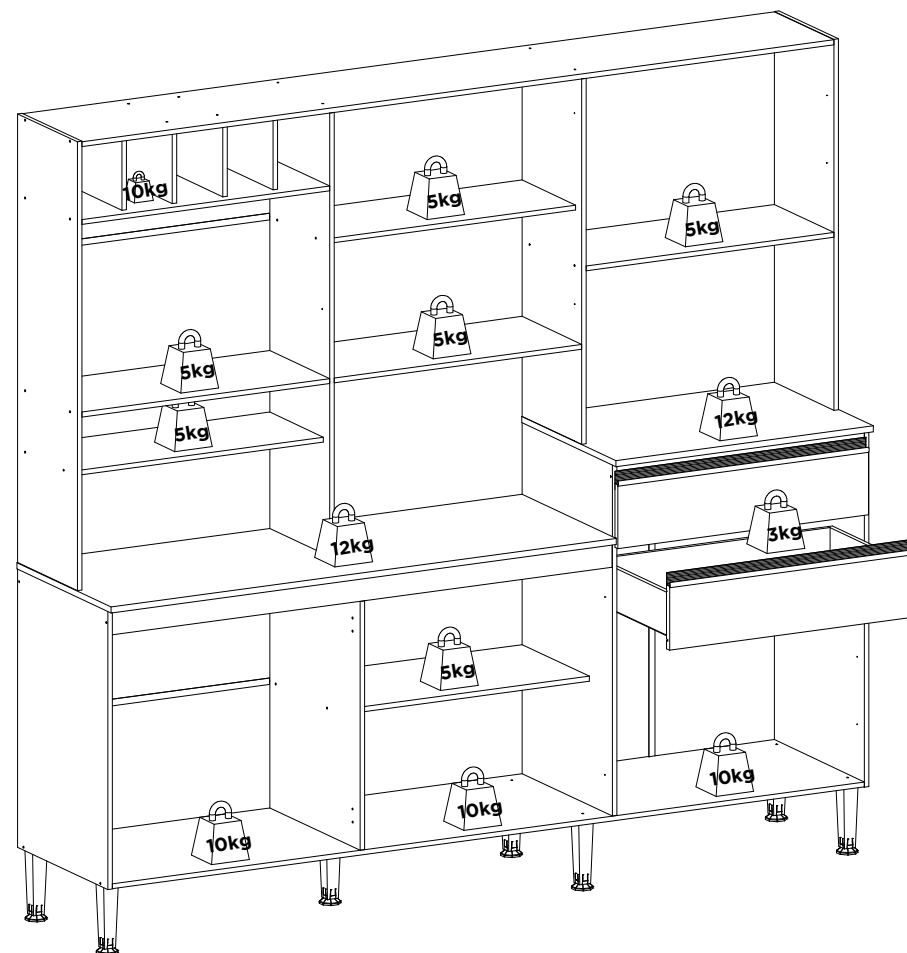

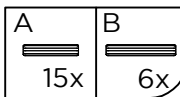
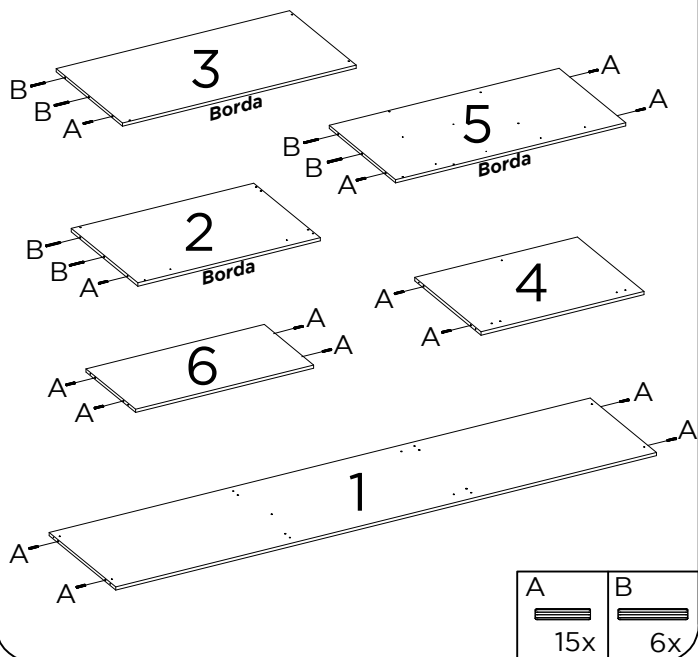
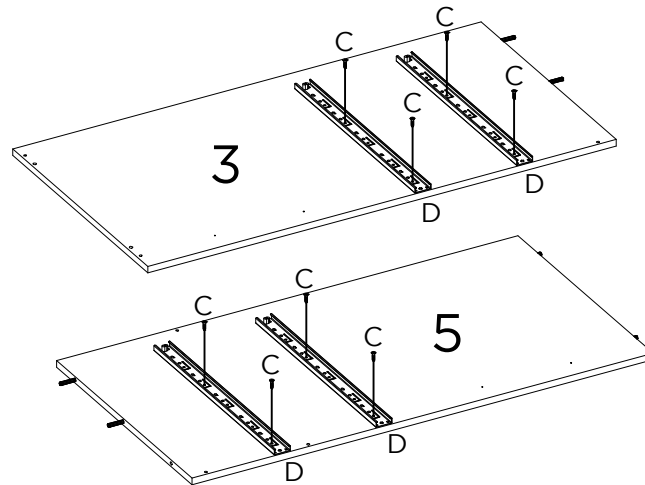
**1****2**

SIGA AS INSTRUÇÕES NA PÁGINA DA  
CORREDIÇA.  
FOLLOW THE INSTRUCTIONS ON THE  
SLIDE PAGE.  
SIGA LAS INSTRUCCIONES EN LA PÁGINA  
DE LA CORREDERA.

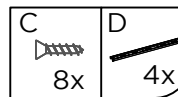
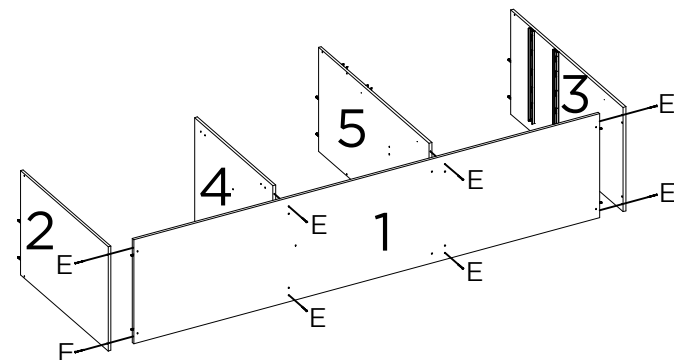
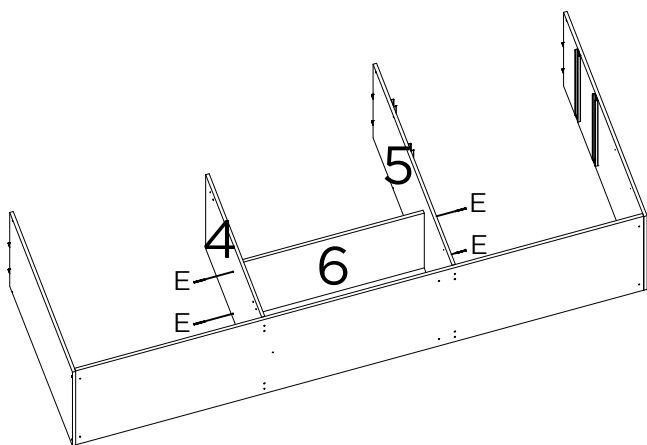
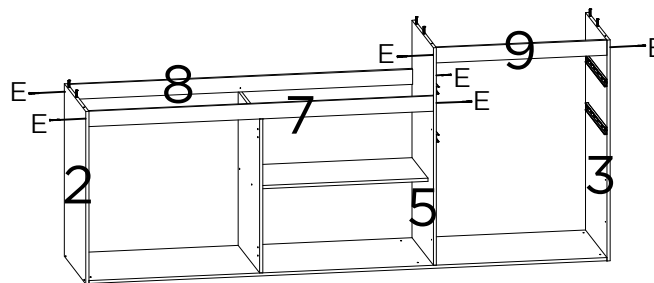
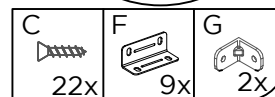
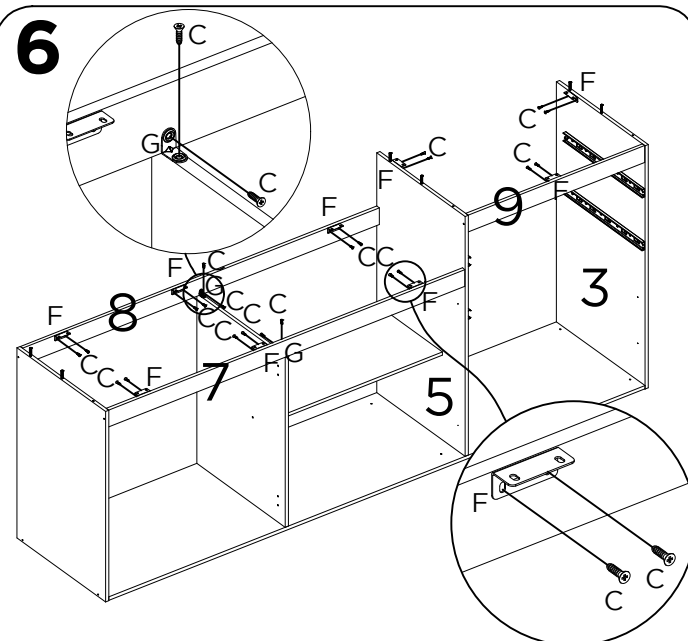
**3****4****5****6**

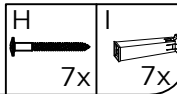
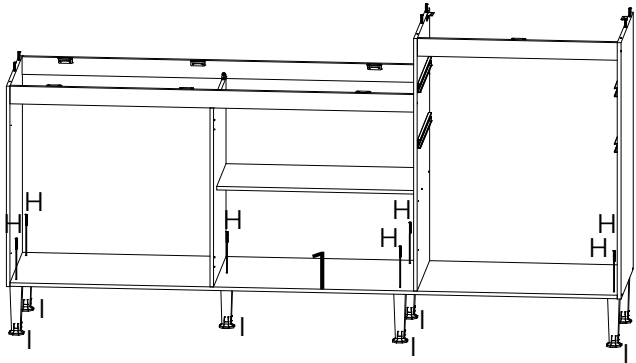
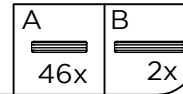
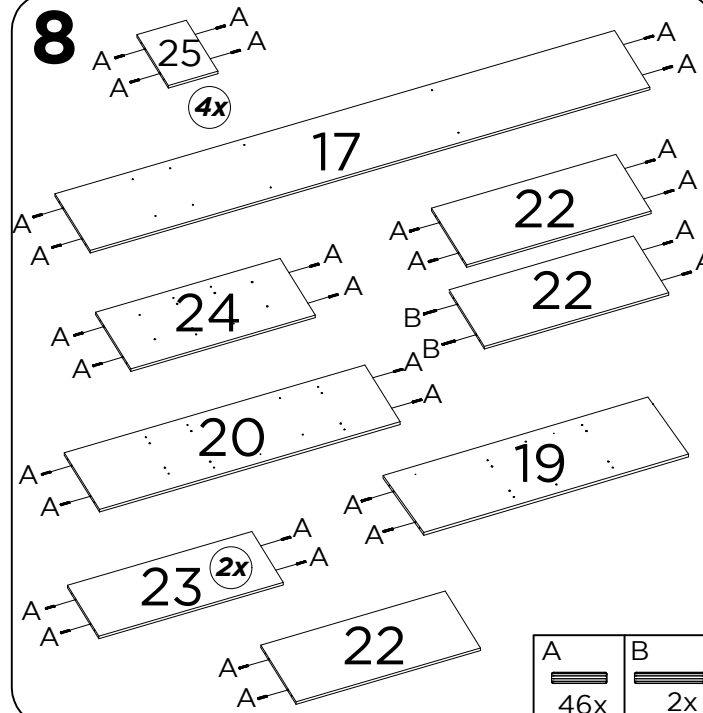
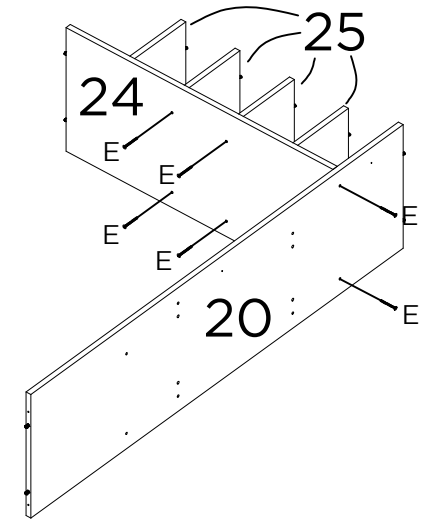
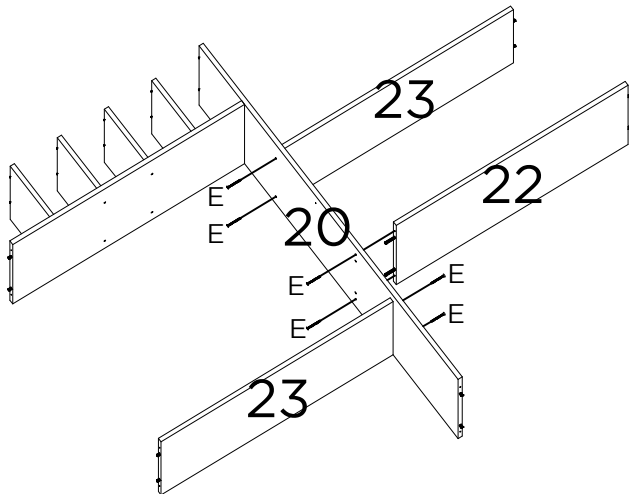
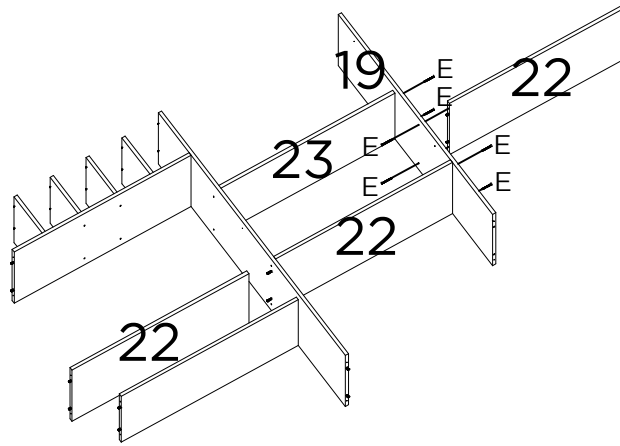
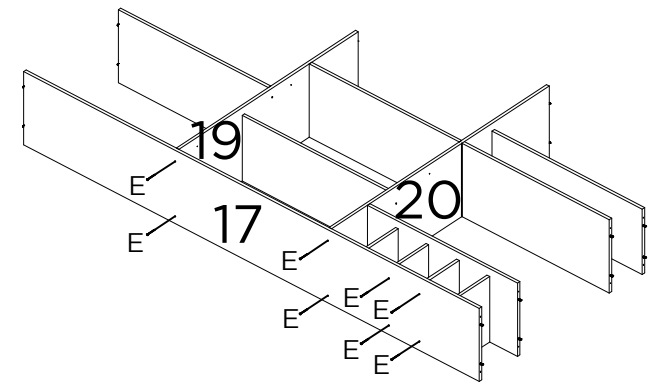
**7****8****9****10****11****12**

# 13

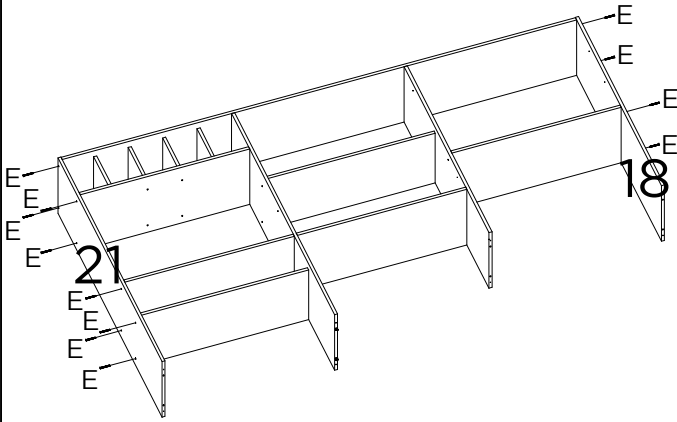

# 14

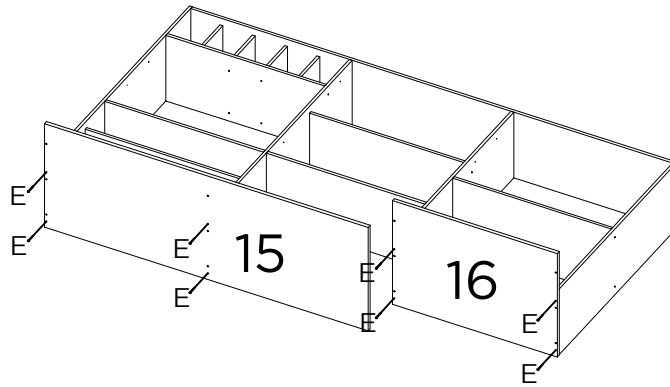

# 15

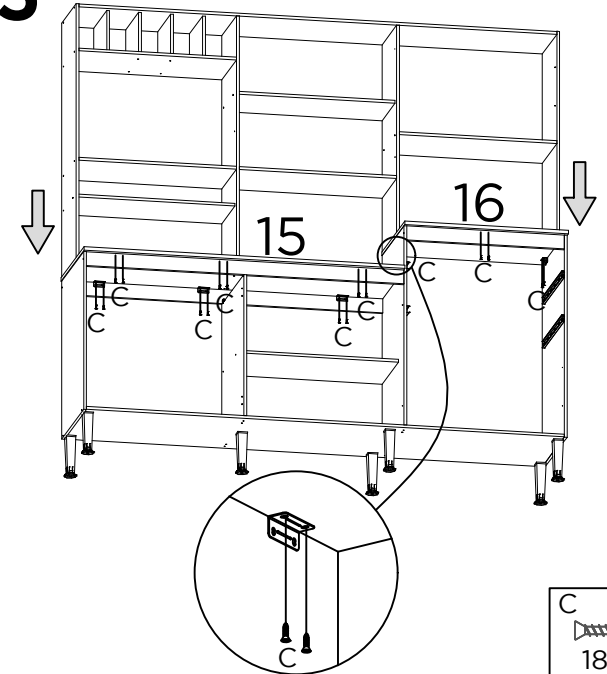

# 16

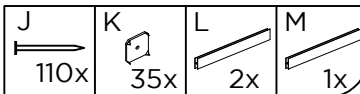
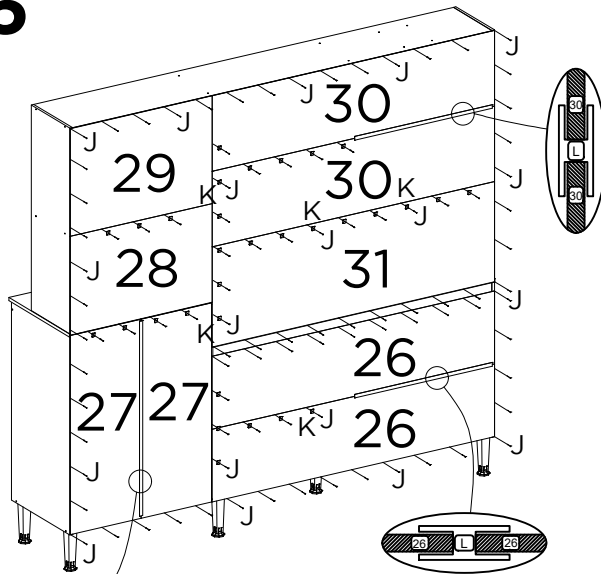

# 17

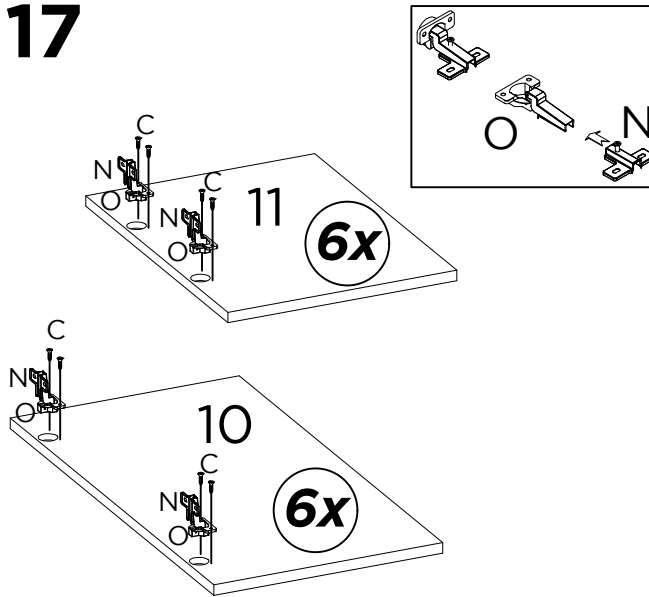

# 18

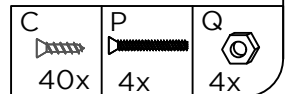
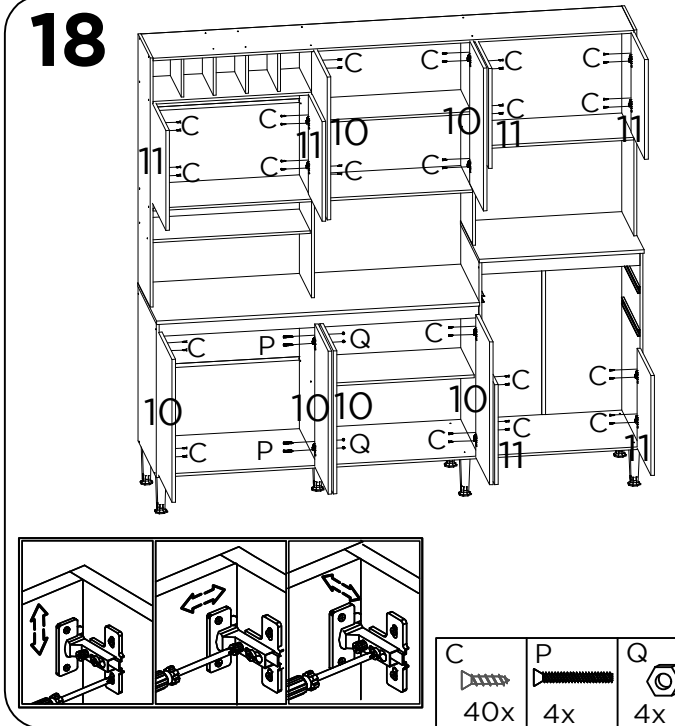

19

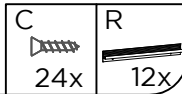
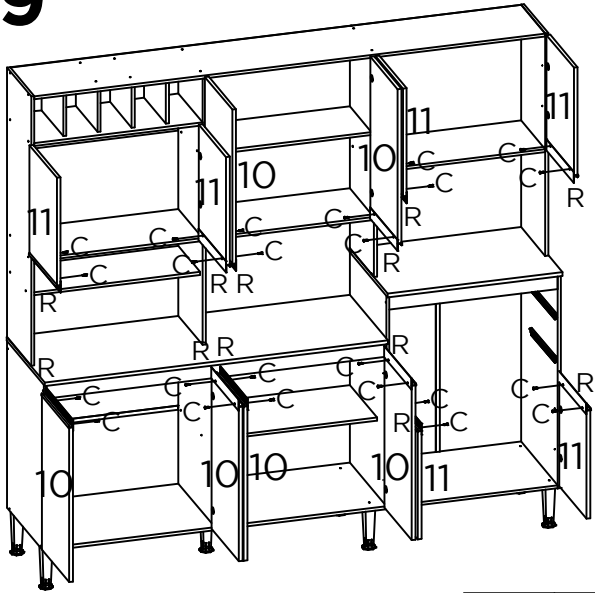

20

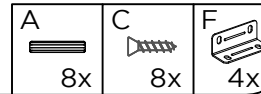
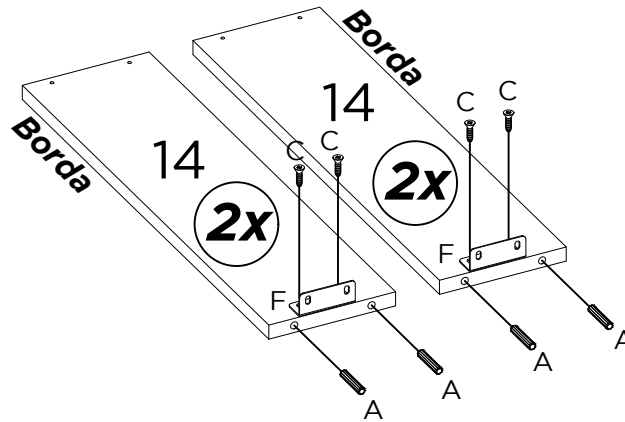

21

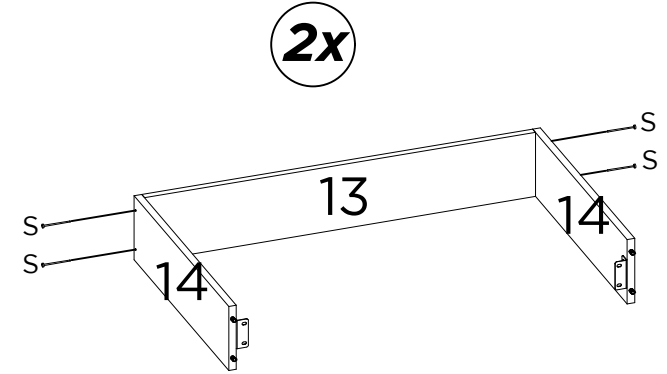

22

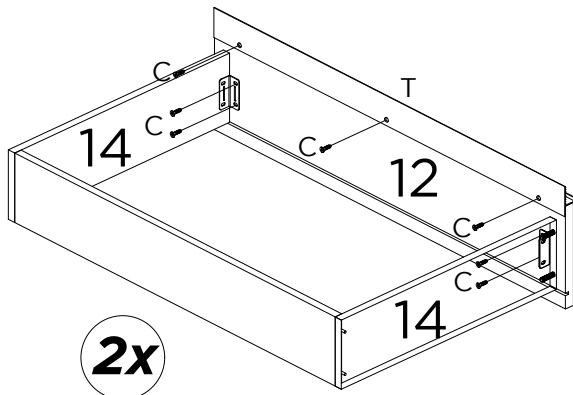

2x

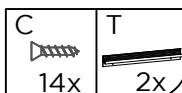

23

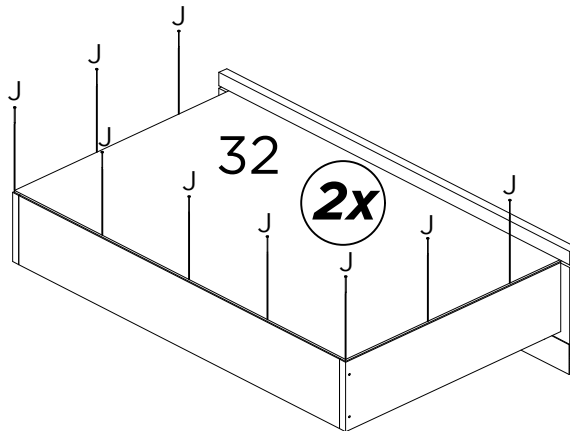

2x



24

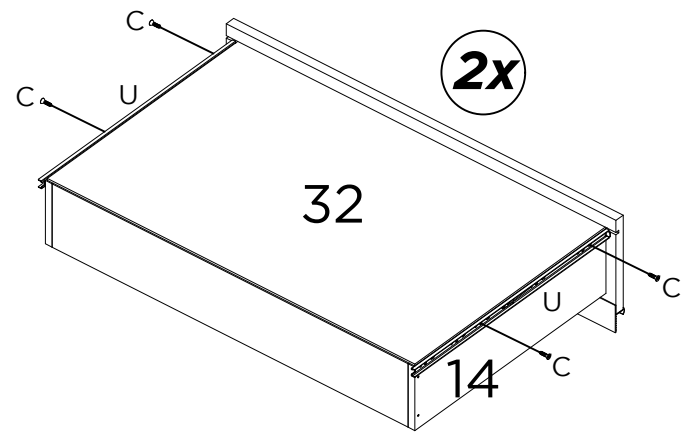

2x

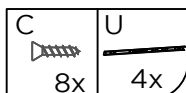

26

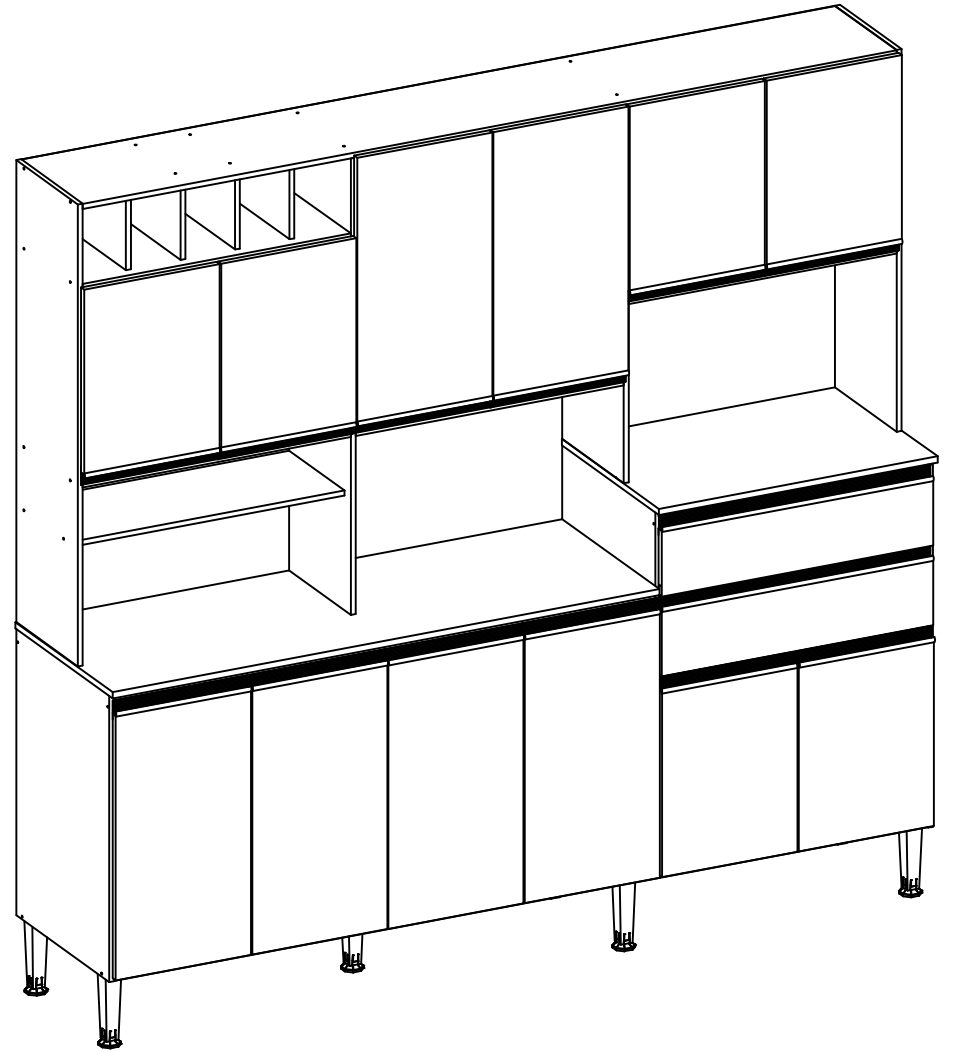
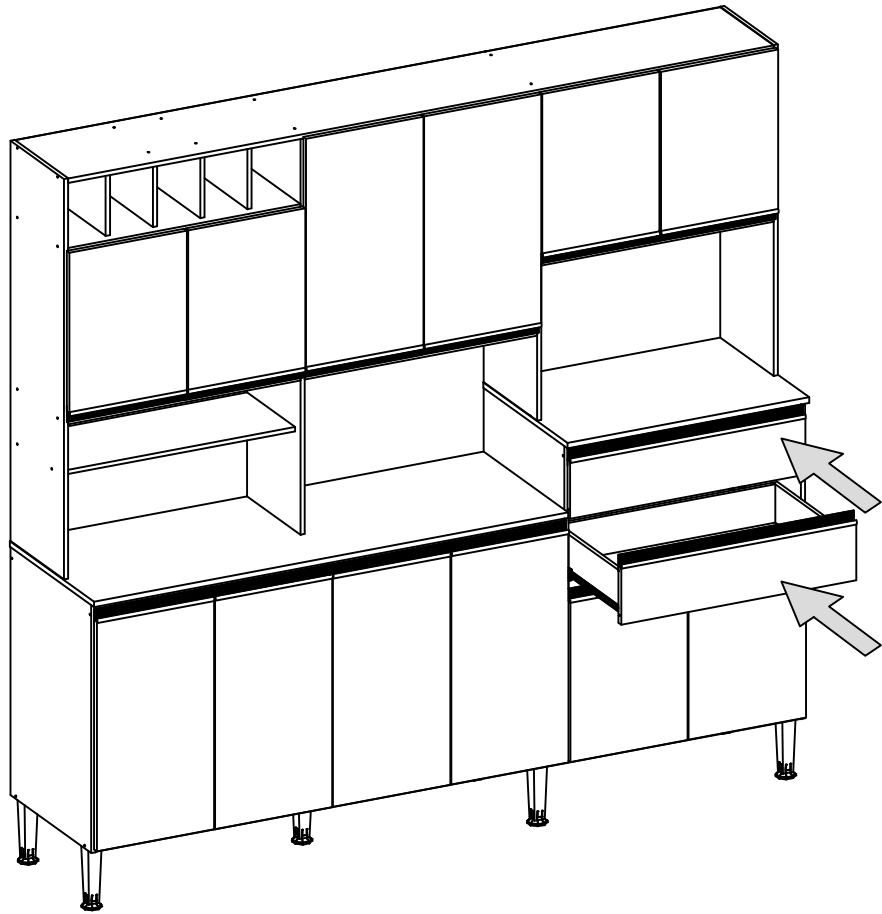

**Para instalar as corrediças telescópicas é necessário seguir os passos, separando as partes que compõem a corrediça.**

To install the telescopic slides, it is necessary to follow the steps, separating the parts that make up the slide.

Para instalar las correderas telescópicas es necesario seguir los pasos, separando las dos partes que componen la pieza.

### Corrediça telescópica / Telescopic slides Corredera telescópica



### Passo 1 / Step 1 / Paso 1

#### Corrediça telescópica aberta / Telescopic slide open / Corredera telescópica abierta

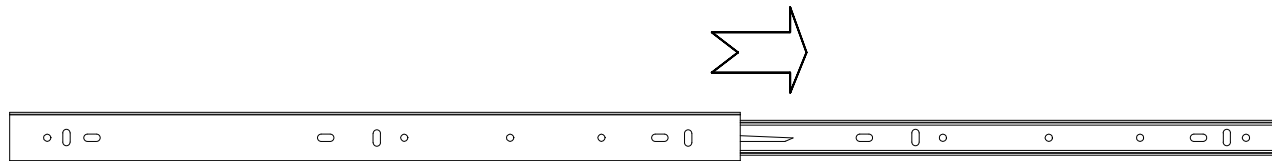

**Para separar as partes da corrediça, puxe o engate que está na parte traseira da corrediça (desenho ao lado) no sentido anti-horário, separando as duas partes, para facilitar a fixação no móvel.**

To separate the parts of the slide, pull the hook on the back of the slide (illustration on the side) counterclockwise, separating the two parts, to facilitate attachment to the furniture.

Para separar las dos partes de la corredera, tire el engate que está en la parte de atrás de la corredera (dibujo al lado) en el sentido anti-horario, separando las dos partes, para facilitar la fijación en el mueble.

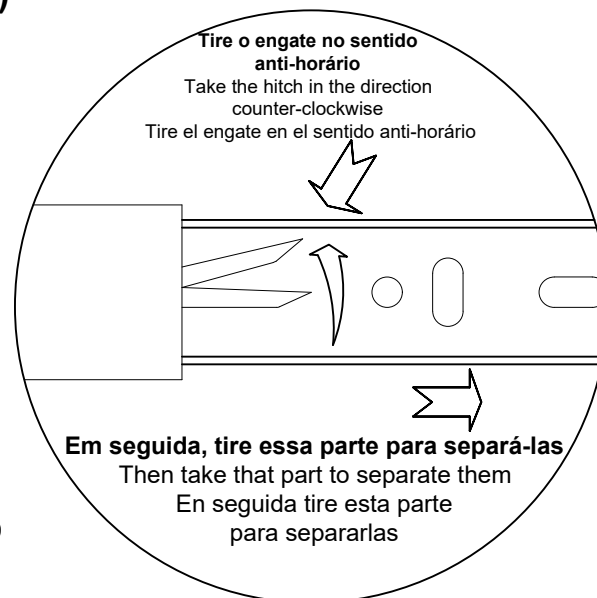

### Passo 2 / Step 2 / Paso 2

**Com as partes da corrediça separadas, fixar-las no móvel.**

With the slide parts separated, fix them to the furniture.

Con las partes de la corredera separadas, fijarlas en el mueble.

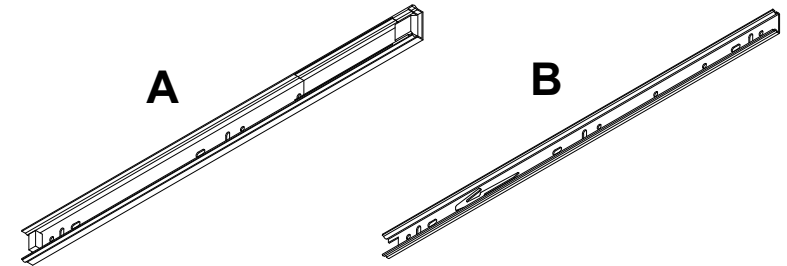

**As corrediças devem ficar alinhadas com a parte inferior das laterais de gavetas.**

The slide should be flush with the underside of the drawer sides.

Las correderas deben quedar aliñada con la parte inferior de las laterales de los cajones.

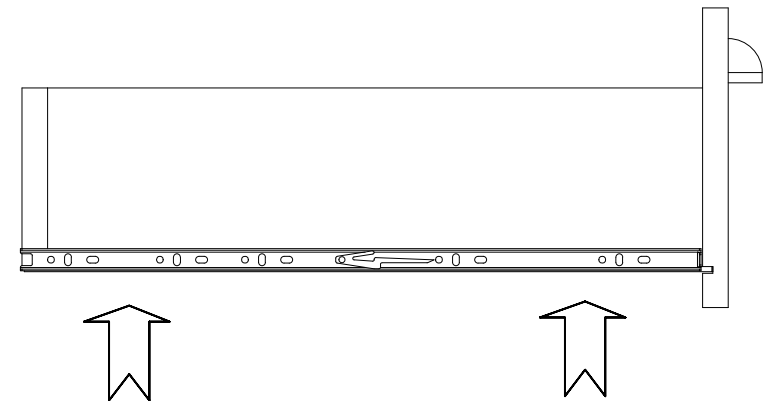

# Agora que você já comprou o seu móvel, ele merece ser montado do jeito certo.

Erros de montagem causam mais de **60%** dos danos em móveis.

## Por que contratar?

Tranquilidade do **início ao fim** da montagem



### PROFISSIONAIS QUALIFICADOS

Especialistas certificados na **MadeiraMadeira Serviços**.



### FERRAMENTAS PROFISSIONAIS

que **protegem** seus móveis.



### AGENDAMENTO EM 24 HORAS

escolha a data e o turno **ideais para** você.



### GARANTIA DE 3 MESES

de cobertura **completa**.

**Mais de 1 MILHÃO DE MONTAGENS**  
★ com avaliação **4.7** ★

#### Mariana S., São Paulo

"Chegaram no horário e montaram tudo rapidamente. Serviço incrível!"



#### Carlos R., Belo Horizonte

"Tentei montar sozinho e foi um desastre. Com a **MadeiraMadeira Serviços** ficou perfeito."



#### Ana P., Rio de Janeiro

"Agendamento ágil e **montagem pontual e perfeita**. Recomendo demais!"



**Agende agora pelo QR Code**

Madeira**Madeira** Serviços · Atendimento em todo o Brasil



Escaneie o QRCode