

CC 0180

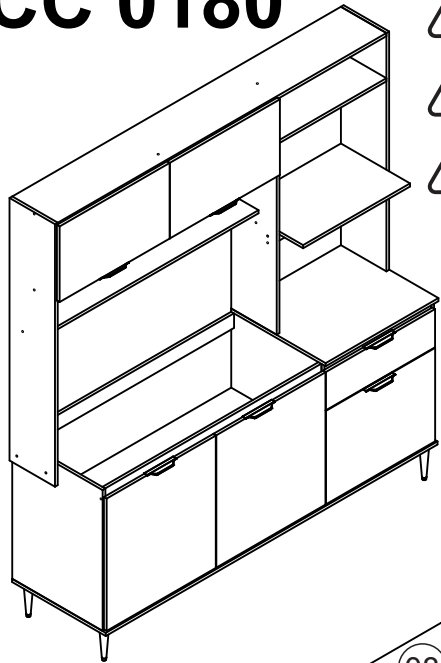

Limpar o número da peça com pano levemente umedecido com álcool



Clean the part number with a cloth slightly dampened with alcohol



Limpiar el número de la pieza con un paño ligeramente humedecido con alcohol.

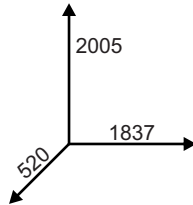

Ferramentas Necessárias:
Herramientas Necessárias:
Necessary Tools:



REF	DESC	C	L	E	QTD
CC0180-01	LATERAL DIREITA/LADO DERECHO/RIGHT SIDE	670	497	15	1
CC0180-02	LATERAL ESQUERDA/LADO IZQUIERDO/LEFT SIDE	670	497	15	1
CC0180-03	BASE/BASE/BASE	1824	515	15	1
CC0180-04	PRATELEIRA/ESTANTE/SHELF	1189	250	15	1
CC0180-05	DIVISÃO/DIVISIÓN/DIVISION	670	497	15	1
CC0180-06	TRAVESSA/TRAVESAÑO/PLATTER	1189	70	15	2
CC0180-07	PILASTRA/PILLAR/PILAR	293	70	15	1
CC0180-08	CHAPEU/SOMBRERO/HAT	1807	250	15	1
CC0180-10	TAMPO/TAPA/TOP	620	520	15	1
CC0180-11	PORTA/PUERTA/DOOR	605	360	15	2
CC0180-12	PORTA/PUERTA/DOOR	630	600	15	2
CC0180-13	PORTA/PUERTA/DOOR	445	600	15	1
CC0180-15	LATERAL GAVETA/LADO DEL CAJÓN/DRAWER SIDE	380	82	15	2
CC0180-18	COSTA GAVETA/COSTA CAJON/DRAWER COAST	533	82	15	1
CC0180-20	FRENTE GAVETA/FRENTE DE CAJÓN/DRAWER FR	182	600	15	1
CC0180-21	LATERAL DIREITA/LADO DERECHO/RIGHT SIDE	1135	250	15	1
CC0180-22	LATERAL ESQUERDA/LADO IZQUIERDO/LEFT SIDE	1250	250	15	1
CC0180-23	BASE/BASE/BASE	1204	250	15	1
CC0180-24	PRATELEIRA/ESTANTE/SHELF	588	380	15	1
CC0180-25	DIVISÃO/DIVISIÓN/DIVISION	1120	250	15	1
CC0180-26	TRAVESSA/TRAVESAÑO/PLATTER	588	70	15	2
CC0180-33	BASE/BASE/BASE	588	250	15	1
CC0180-34	PRATELEIRA/ESTANTE/SHELF	1204	150	15	1
CC0180-36	TRAVESSA/TRAVESAÑO/PLATTER	588	70	15	1
CC0180-37	PILASTRA/PILLAR/PILAR	600	70	15	1
CC0180-46	TRAVESSA/TRAVESAÑO/PLATTER	347	70	15	1
CC0180-47	APOIO GAVETA/SOPORTE CAJÓN/DRAWER SUP	380	70	15	1
CC0180-60	COSTA/FONDO/BACK	1220	366	3	1
CC0180-61	COSTA/FONDO/BACK	1814	310	3	2
CC0180-62	COSTA/FONDO/BACK	1220	232	3	1
CC0180-63	COSTA/FONDO/BACK	610	220	3	1
CC0180-64	COSTA/FONDO/BACK	610	438	3	1
CC0180-65	FUNDO GAVETA/FONDO DE CAJÓN/DRAWER F	558	385	3	1

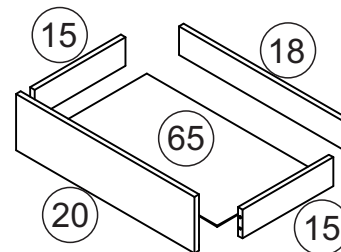
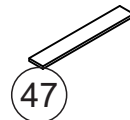
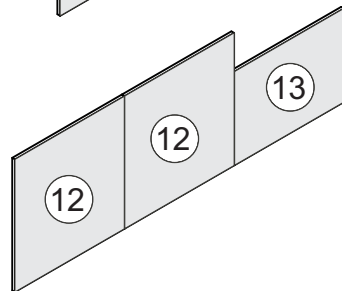
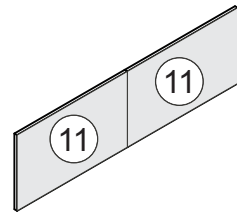
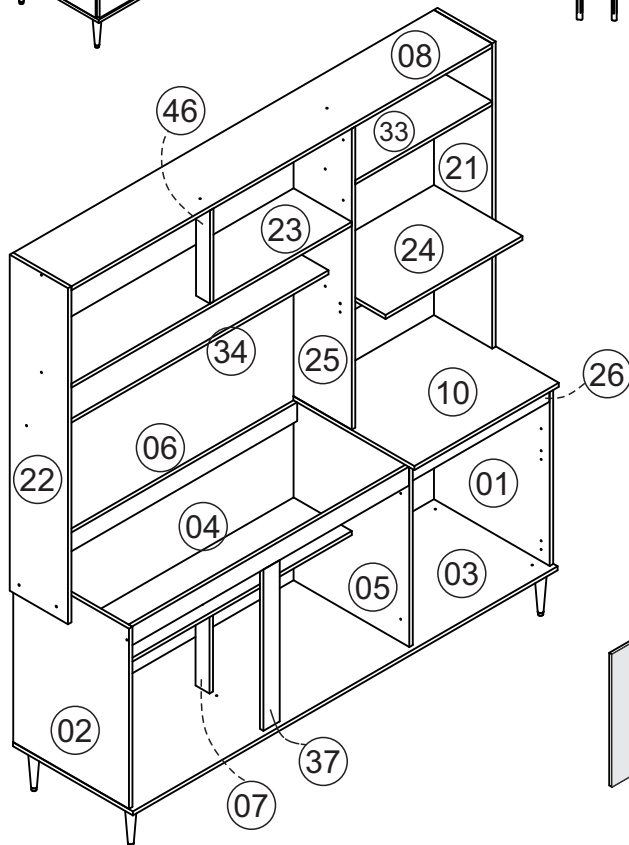

G		SUPORTE FIXAÇÃO SOPORTE DE FIJACIÓN FIXING SUPPORT	02
H		PROTEÇÃO SUP CANTONEIRA PROTECCIÓN ANGLE BRACKET	02
I		BUCHA PLÁSTICA CASQUILLO BUSHING	02

dm
DELMARCO

A		CAVILHA Ø6X30 CLAVIJA Ø6X30 WOOD DOWEL Ø6X30	56
B		PARAFUSO CC 3,5X14 TORNILLO CC 3,5X14 SCREW CC 3,5X14	48
C		PARAFUSO CC 3,5X40 TORNILLO CC 3,5X40 SCREW CC 3,5X40	34
DB		DOBRADIÇA 35 BISAGRA HINGE	10
F		PARAFUSO CF 4,5X50 TORNILLO CF 4,5X50 SCREW CF 4,5X50	08
M		PREGO 10X10 CLAVO 10X10 NAIL	100
L		CANTONERA ESQUINERO CORNER	10
W		PARAFUSO DE UNIÃO TORNILLO UNIÓN UNION SCREW	02
V		COLA PEGAMENTO GLUE	01
PE		PÉ PIE FOOT	06
PX		PUXADOR TIRADOR HANDLE	06
R		GARRA METAL GARRA METALICA METAL CLAW	10
E		PARAFUSO CC 3,5X16 TORNILLO CC 3,5X16 SCREW CC 3,5X16	60
CR		CORREDEIRA 350 CORREDERA SLIDE	01
S		CHAPA FIXAÇÃO PLACA DE FIJACIÓN FIXING PLATE	01
U		ADESIVO TAPA FURO ADHESIVO STICKER	11 FREJO
U1		ADESIVO TAPA FURO ADHESIVO STICKER	03 ARENAS

**INSTRUÇÕES DE MONTAGEM
ASSEMBLY'S INSTRUCTIONS
INSTRUCCIONES DE MONTAJE**

"IMPORTANTE LER COM ATENÇÃO E GUARDAR PARA EVENTUAIS CONSULTAS".
"IMPORTANTE LEER CON ATENCIÓN Y GUARDAR PARA EVENTUALES CONSULTAS".
"IMPORTANT TO READ CAREFULLY AND SAVE FOR ANY QUERIES".

1 **CC 0180**

CR

Y¹ Y²

01 05

B B

Y²

2

Fixar as cavilhas c/ cola
Fije los pivotes con cola
Attach the dowels with glue

C C C C C C C C

08 23 34 25 21 36 24 33

22

C C C C C C C C

3

dm
DELMARCO

S

X4 B

06 26 01

06 05

02 03

C C C C C C C C

F 03 PE

4

PX B B

20 B B

L B B

15 65 18

B Y¹

47

C C

5

B B L 01

05 L

PX B PX

11 12 13

W W

E E DB E E

6

U

H I B F B

H G

60 62 63 64 61 61

M R

! FIXAR NA PAREDE
FIJAR A LA PARED
FIX TO THE WALL