



JCM
movelaria

Rack Cristal Cristal TV Stand Mesa de TV Cristal



Cupom: JCM30

















Indicamos que a montagem dos produtos seja realizada com parafusadeira eléctrica e por um montador profissional.
We recommend that a professional furniture assembler assemble the product by using a cordless screwdriver.
Se recomienda que un montador de muebles profesional realice el montaje del producto con un destornillador eléctrico.

AVISO: Não nos comprometemos pelo mal-uso, montagem e fixação do produto à parede. Portanto, não somos responsáveis por danos e quedas do produto, eletrônicos e pertences neles contidos. É importante o uso de brocas e ferramentas compatíveis na montagem.
NOTICE: The company is not responsible for the misuse, assembly, and wall fixation, as well as the damages and falls that the products, electronics, and belongings therein might suffer. It is important to use suitable drills and tools to assemble the product.
ATENCIÓN: La empresa no se responsabiliza del mal uso, montaje y fijación del producto a la pared, así como de daños y caídas del producto, electrónicos u objetos. Es importante el uso de taladros y herramientas compatibles con el montaje.

Dica: para evitar possíveis avarias, use a embalagem do produto como apoio durante a montagem.
Tip: to avoid damages, use the product packaging as a base during the assembly.
Pista: para evitar daños, use el envase del producto como apoyo durante el montaje.

RELAÇÃO DE FERRAGENS | HARDWARE LIST | LISTADO DE HERRAJES

ARRUELA LISA (B)	FLAT WASHER (B)	ARANDELA LISA (B)		08
CALÇO DOBRADIÇA 12mm (C)	12mm HINGE MOUNTING PLATE (C)	BASE DE BISAGRA 12 mm (C)		04
CAVILHA 6x30 (D)	6x30 DOWEL (D)	CLAVIJA 6x30 (D)		08
CHAPA UNIAO 4 FUROS (E)	4-HOLE CONNECTION PLATE (E)	PLACA DE UNIÓN 4 AGUJEROS (E)		04
CONEXÃO ANGULAR 4 FUROS (H)	4-HOLE CORNER JOINT BRACKET (H)	SOPORTE ANGULAR 4 AGUJEROS (H)		10
DOBRADIÇA ALTA 26mm (I)	26mm HALF-OVERLAY HINGE (I)	BISAGRA ACODADA 26 mm (I)		04
FIXADOR METÁLICO (J)	METAL FIXING PLATE (J)	GRAPA METÁLICA (J)		12
PARAFUSO CHP CHA BC 3,5x14 (K)	3.5x14 FLAT-HEAD SCREW (K)	TORNILLO CABEZA PLANA 3,5x14 (K)		08
PARAFUSO 3,5x14 FLANGEADO (L)	3.5x14 FLANGE SCREW (L)	TORNILLO TIPO FLANGE 3,5x14 (L)		56
PARAFUSO CHP CHA BC 4x25 (M)	4x25 FLAT-HEAD SCREW (M)	TORNILLO CABEZA PLANA 4x25 (M)		04
PARAFUSO CHP CHA BC 4x35 (N)	4x35 FLAT-HEAD SCREW (N)	TORNILLO CABEZA PLANA 4x35 (N)		02
PARAFUSO ESTR CHA PHI ZP 5x40 (O)	5x40 FLAT-HEAD SCREW (O)	TORNILLO CABEZA PLANA 5x40 (O)		24
PARAFUSO MINIFIX (P)	MINIFIX BOLT (P)	PERNO MINIFIX (P)		18
PARAFUSO MA CHA PHI ZB M4x25 (Q)	M4x25 FLAT-HEAD PHILLIPS SCREW (Q)	TORNILLO PHILLIPS CABEZA PLANA M4x25 (Q)		08
PORCA M4 (R)	M4 NUT (R)	TUERCA M4 (R)		08
PREGO 8x8 C/C (S)	8x8 NAIL (S)	CLAVO 8x8 (S)		45
TAMBOR MINIFIX 12x10mm (T)	12x10mm MINIFIX CAM LOCK (T)	CAJA DEL MINIFIX 12x10 mm (T)		18

RELAÇÃO DE PEÇAS | PARTS LIST | LISTADO DE PARTES

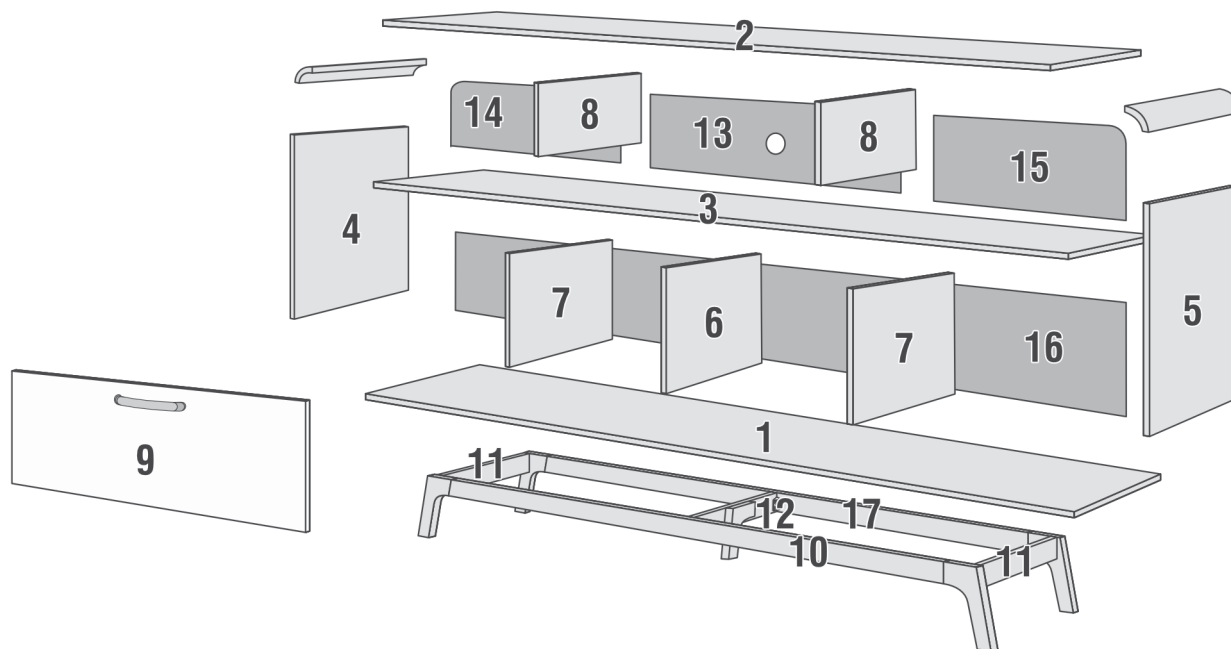
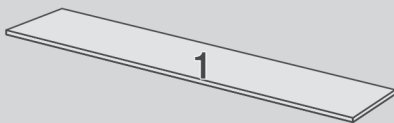
1 BASE
BOTTOM
BASE 1PC
1PC
1PZA



10 RODAPÉ FRONTAL
FRONT TOE
ZÓCALO FRONTAL 1PC
1PC
1PZA



2 TAMPO
TOP
TAPA 1PC
1PC
1PZA



11 RODAPÉ LATERAL
SIDE TOE
ZÓCALO LATERAL 2PCS
2PCS
2PZAS



3 TAMPO PORTA
SHELF
REPISA 1PC
1PC
1PZA



12 RODAPÉ INTERNO
INTERNAL TOE
ZÓCALO INTERNO 1PC
1PCS
1PZA



4 LATERAL ESQUERDA
LEFT SIDE
LATERAL IZQUIERDO 1PC
1PC
1PZA



13 COSTAS COM FURO
BACK PANEL WITH HOLE
TRASERA CON AGUJERO 1PC
1PC
1PZA



5 LATERAL DIREITA
RIGHT SIDE
LATERAL DERECHO 1PC
1PC
1PZA



14 COSTAS SUPERIOR ESQUERDA
LEFT BACK PANEL
TRASERA SUPERIOR IZQUIERDA 1PC
1PC
1PZA



15 COSTAS SUPERIOR DIREITA
RIGHT BACK PANEL
TRASERA SUPERIOR DERECHA 1PC
1PC
1PZA



6 DIVISÃO CENTRAL INFERIOR
BOTTOM CENTRAL DIVIDER
DIVISIÓN CENTRAL INFERIOR 1PC
1PC
1PZA



16 COSTAS INFERIOR
BOTTOM BACK PANEL
TRASERA INFERIOR 1PC
1PC
1PZA



7 DIVISÃO INFERIOR
RIGHT/LEFT BOTTOM DIVIDER
DIVISIÓN INFERIOR IZQUIERDA/DERECHA 2PCS
2PCS
2PZAS



17 RODAPÉ TRASEIRO
BACK TOE
ZÓCALO TRASERO 1PC
1PC
1PZA



8 DIVISÃO SUPERIOR
TOP DIVIDERS
DIVISIONES SUPERIORES 2PCS
2PCS
2PZAS



9 MOLDURA LATERAL ARREDONDADA
ROUNDED CORNER FRAME
MARCO LATERAL REDONDEADO 2PCS
2PCS
2PZAS



9 PORTA
DOOR
PUERTA 2PCS
2PCS
2PZAS



9 PÉ
FEET
PATAS 5PCS
5PCS
5PZAS

Passo 01 INICIE A MONTAGEM PELA PEÇA 2, ENCAIXANDO AS MOLDURAS REDONDAS COM CAVILHA 6x30 (D) E MINIFIX (P+T).

Step 01 START THE ASSEMBLY FROM PART 2 BY FASTENING THE ROUNDED CORNER FRAMES WITH 6x30 DOWELS AND MINIFIX (P+T).

Paso 01 EMPIECE EL MONTAJE POR LA PARTE 2, FIJÁNDOLE LOS MARCOS LATERALES REDONDEADOS CON CLAVIJAS 6x30 (D) Y MINIFIX (P+T).

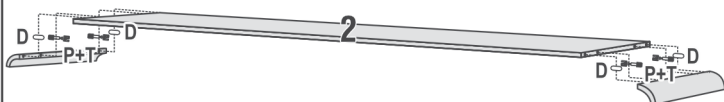

D=4 

P=4  T=4 

Passo 02 ENCAIXE AS PEÇAS 8 NA PEÇA 2 COM MINIFIX (P+T).

Step 02 ATTACH PARTS 8 TO PART 2 WITH MINIFIX (P+T).

Paso 02 FIJE LAS PARTES 8 A LA PARTE 2 CON MINIFIX (P+T).

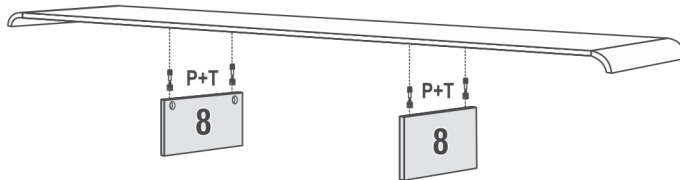



P=4  T=4 

Passo 03 PARAFUSE A PEÇA 3 NAS PEÇAS 8 COM PARAFUSO 5x40 (O). ENCAIXE AS PEÇAS 4 E 5 NAS MOLDURAS REDONDAS COM CAVILHA 6x30 (D) E MINIFIX (P+T), E PARAFUSE-AS NA PEÇA 3 COM PARAFUSO 5x40 (O).

Step 03 FASTEN PART 3 TO PARTS 8 WITH 5x40 SCREWS (O). FASTEN PARTS 4 AND 5 TO THE ROUNDED CORNER FRAMES WITH 6x30 DOWELS (D) AND MINIFIX (P+T), AND ATTACH THEM TO PARTS 3 WITH 5x40 SCREWS (O).

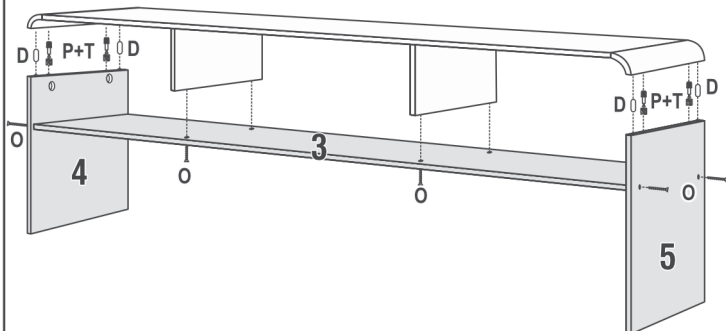
Paso 03 FIJE A LA PARTE 3 A LAS PARTES 8 CON TORNILLOS 5x40 (O). ENCAJE LAS PARTES 4 Y 5 EN LOS MARCOS LATERALES REDONDEADOS CON CLAVIJAS 6x30 (D) Y MINIFIX (P+T), Y FIJELAS A LA PARTE 3 CON TORNILLOS 5x40 (O).

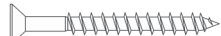

D=4  O=8 

P=4  T=4 

Passo 04 ENCAIXE AS PEÇAS 6 E 7 NA PEÇA 3 COM MINIFIX (P+T). EM SEGUIDA, PARAFUSE A PEÇA 1 NAS PEÇAS 4, 5, 6 E 7 COM PARAFUSO 5x40 (O).

Step 04 ATTACH PARTS 6 AND 7 TO PART 3 WITH MINIFIX (P+T). NEXT, FASTEN PART 1 TO PARTS 4, 5, 6, AND 7 WITH 5x40 SCREWS (O).

Paso 04 ENCAJE LAS PARTES 6 Y 7 EN LA PARTE 3 CON MINIFIX (P+T). LUEGO, FIJE LA PARTE 1 A LAS PARTES 4, 5, 6 Y 7 CON TORNILLOS 5x40 (O).

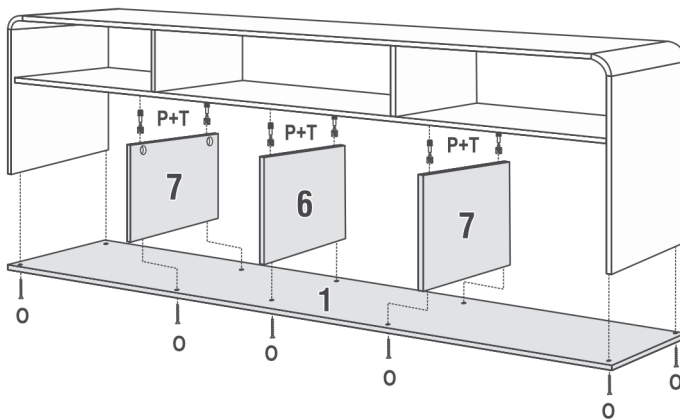

O=10 

P=6  T=6 

Passo 05 PARAFUSE AS PEÇAS 11 E 12 NA PEÇA 1 COM PARAFUSO 5x40 (O). PARAFUSE AS PEÇAS 10 E 17 NOS PÉS USANDO CHAPA 4 FUROS (E+K). EM SEGUIDA, ALINHE E PARAFUSE OS PÉS NAS PEÇAS 11 COM CONEXÃO ANGULAR (H+L). PARAFUSE AS CONEXÕES ANGULARES NAS PEÇAS 10 E 17 COM A PEÇA 1, E PARAFUSE O PÉ CENTRAL NA PEÇA 12 COM PARAFUSO 4x35 (N).

Step 05 ATTACH PARTS 11 AND 12 TO PART 1 WITH 5x40 SCREWS (O). ATTACH THE FEET TO PARTS 10 AND 17 WITH 4-HOLE CONNECTION PLATES (E+K). NEXT, ALIGN AND ATTACH THE FEET TO PARTS 11 WITH CORNER JOINT BRACKETS (H+L). FASTEN THE CORNER JOINT BRACKETS TO PARTS 10 AND 17 WITH PART 1, AND ATTACH THE MIDDLE FOOT TO PART 12 WITH 4x35 SCREWS (N).

Paso 05 FIJE LAS PARTES 11 Y 12 A LA PARTE 1 CON TORNILLOS 5x40 (O). FIJE LAS PARTES 10 Y 17 A LAS PATAS CON PLACAS DE UNIÓN 4 AGUJEROS (E+K). NEXT, ALINEE Y ATORNILLE LAS PATAS A LAS PARTES 11 CON SOPORTES ANGULARES (H+L). ATORNILLE LOS SOPORTES ANGULARES A LAS PARTES 10 Y 17 CON LA PARTE 1, Y FIJE LA PATA CENTRAL A LA PARTE 12 CON TORNILLOS 4x35 (N).

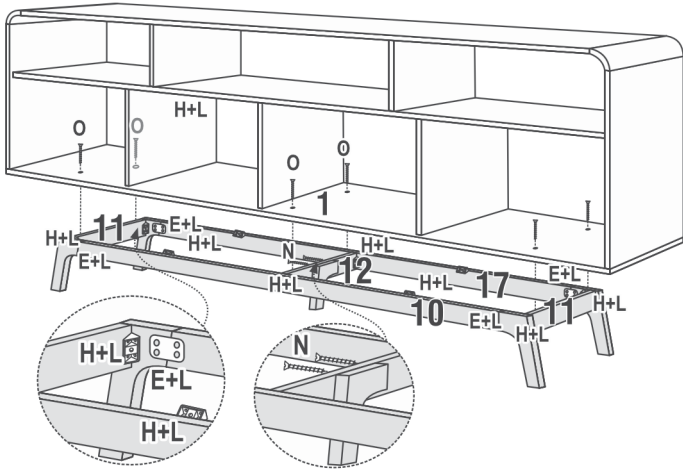

VISTA INFERIOR | **BOTTOM VIEW** | VISTA DESDE ABAJO

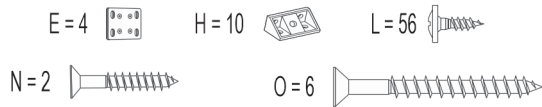
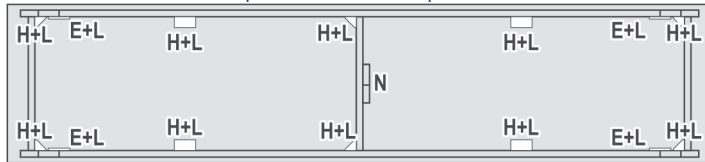

Passo 06 PREGUE AS COSTAS COM PREGO (S).

Step 06 FASTEN THE BACK PANELS WITH NAILS (S).

Paso 06 FIJE LOS PANELES TRASEROS CON CLAVOS (S).

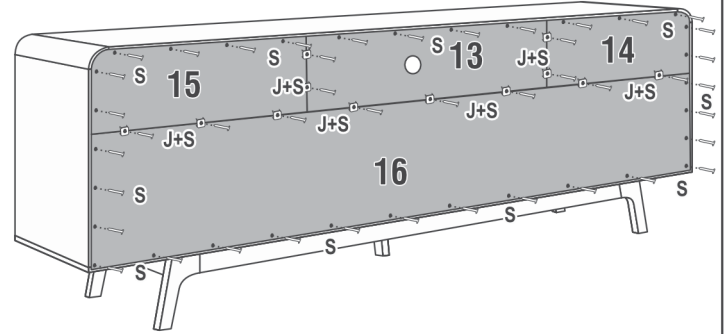

Passo 07 MONTE E INSTALE AS PORTAS COM AS RESPECTIVAS FERRAGENS.

Step 07 INSTALL THE DOORS WITH THEIR HARDWARE.

Paso 07 MONTE E INSTALE LAS PUERTAS CON SUS HERRAJES.

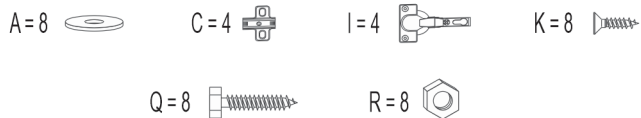
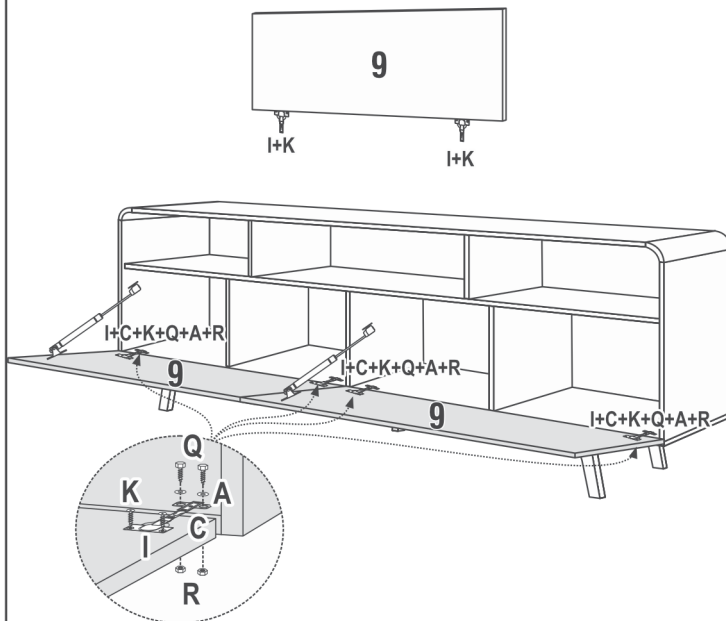

Passo 07 COLOQUE OS PUXADORES NAS PORTAS.

Step 07 FASTEN THE HANDLES TO THE DOORS.

Paso 07 ATORNILLE LOS TIRADORES A LAS PUERTAS.

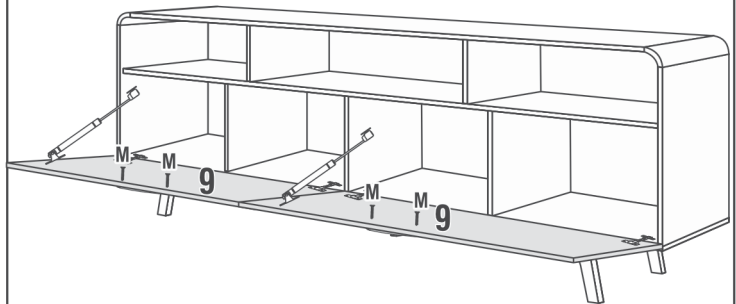



JCM
movelaria

PAINEL CRISTAL CRISTAL TV PANEL PANEL TV CRISTAL



Cupom: JCM30













Indicamos que a montagem dos produtos seja realizada com parafusadeira eléctrica e por um montador profissional.
We recommend that a professional furniture assembler assemble the product by using a cordless screwdriver.
Se recomienda que un montador de muebles profesional realice el montaje del producto con un destornillador eléctrico.

AVISO: Não nos comprometemos pelo mal-uso, montagem e fixação do produto à parede. Portanto, não somos responsáveis por danos e quedas do produto, eletrônicos e pertences neles contidos. É importante o uso de brocas e ferramentas compatíveis na montagem.
NOTICE: The company is not responsible for the misuse, assembly, and wall fixation, as well as the damages and falls that the products, electronics, and belongings therein might suffer. It is important to use suitable drills and tools to assemble the product.
ATENCIÓN: La empresa no se responsabiliza del mal uso, montaje y fijación del producto a la pared, así como de daños y caídas del producto, electrónicos u objetos. Es importante el uso de taladros y herramientas compatibles con el montaje.

Dica: para evitar possíveis avarias, use a embalagem do produto como apoio durante a montagem.
Tip: to avoid damages, use the product packaging as a base during the assembly.
Pista: para evitar daños, use el envase del producto como apoyo durante el montaje.

RELAÇÃO DE FERRAGENS | HARDWARE LIST | LISTADO DE HERRAJES

BUCHA GESSO 10mm	(A)	10mm DRYWALL ANCHOR	(A)	TACO PARA YESO 10 mm	(A)		04
CAVILHA 8x70	(B)	8x70 DOWEL	(B)	CLAVIJA 8x70	(B)		02
CHAPA UNIAO 4 FUROS	(C)	4-HOLE CONNECTION PLATE	(C)	PLACA DE UNIÓN 4 AGUJEROS	(C)		03
PARAFUSO CHP CHA BC 3,5x14	(D)	3.5x14 FLAT-HEAD SCREW	(D)	TORNILLO CABEZA PLANA 3,5x14	(D)		12
PARAFUSO CHP CHA BC 4x25	(E)	4x25 FLAT-HEAD SCREW	(E)	TORNILLO CABEZA PLANA 4x25	(E)		08
PARAFUSO 5x25 FLANGEADO	(F)	5x25 FLANGE SCREW	(F)	TORNILLO TIPO FLANGE 5x25	(F)		04
PARAFUSO ESTR AL ZP/BC 7x60	(G)	7x60 SCREW	(G)	TORNILLO 7x60	(G)		04
PARAFUSO ESTR AL ZP/BC 7x80	(H)	7x80 SCREW	(H)	TORNILLO 7x80	(H)		04
PASSA FIO 40mm	(I)	40mm CABLE GROMMET	(I)	PASACABLES 40 mm	(I)		01
SACHÊ DE COLA	(J)	GLUE SACHET	(J)	BOLSITA DE PEGAMENTO	(J)		01

RELAÇÃO DE PEÇAS | PARTS LIST | LISTADO DE PARTES

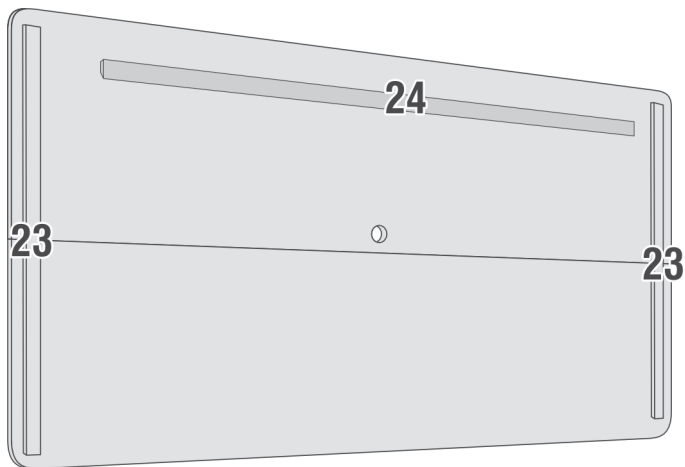
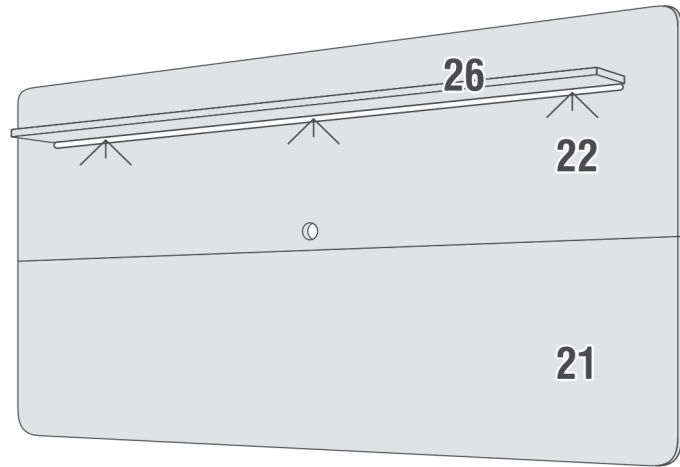

VISTA TRASEIRA
BACK VIEW
VISTA TRASERA

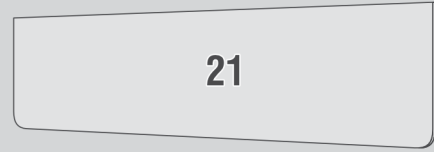

PAINEL INFERIOR
LOWER PANEL
PANEL INFERIOR

1PC
1PC
1PZA

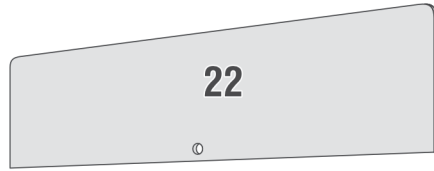

PAINEL SUPERIOR
TOP PANEL
PANEL SUPERIOR

1PC
1PC
1PZA



RÉGUA SUPORTE PAINEL SUP.
BACK STRIP
LISTÓN TRASERO

2PCS
2PCS
2PZAS



RÉGUA MACHO
MALE WOOD JOINT
LISTÓN DE ENCAJE MACHO

1PC
1PC
1PZA



RÉGUA FÊMEA
FEMALE WOOD JOINT
LISTÓN DE ENCAJE HEMBRA

1PC
1PC
1PZA



PRATELEIRA SUPERIOR
TOP SHELF
REPISA SUPERIOR

1PC
1PC
1PZA



LUMINÁRIA
LED LIGHTS
LUCES LED

1PC
1PC
1PZA

PASSO 01 ALINHE OS PAINÉIS 21 E 22, PARAFUSANDO AS CHAPAS 4 FUROS (C+D).
STEP 01 ALIGN AND JOIN PANELS 21 AND 22 TOGETHER WITH 4-HOLE CONNECTION PLATES (C+D).
 PASO 01 ALINEE Y UNA LOS PANELES 21 Y 22 CON PLACAS DE UNIÓN 4 AGUJEROS (C+D).

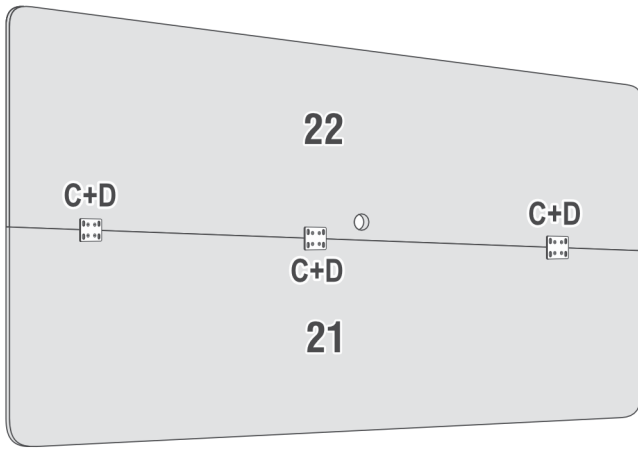

VISTA TRASEIRA
BACK VIEW
 VISTA TRASERA

C = 3  D = 12 

PASSO 02 PARAFUSE AS PEÇAS 23 COM PARAFUSO 4x25 (E).
STEP 02 ATTACH PARTS 23 TO THE PANELS WITH 4x25 SCREWS (E).
 PASO 02 FIJE LAS PARTES 23 CON TORNILLOS 4x25 (E).

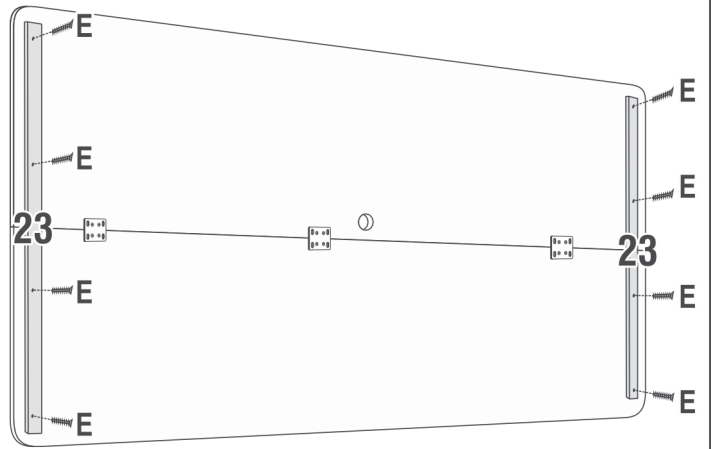

VISTA TRASEIRA
BACK VIEW
 VISTA TRASERA

E = 8 

PASSO 03 ENCAIXE AS CAVILHAS 8x70 (B) NA PEÇA 26 E ENCAIXE A PEÇA 26 NO PAINEL 22.
STEP 03 INSERT THE 8x70 DOWELS (B) INTO PART 26 AND ATTACH IT TO PANEL 22.
 PASO 03 ENCAJE LAS CLAVIJAS 8x70 (B) EN LA PARTE 26 Y FÍJELA A LA PARTE 22.

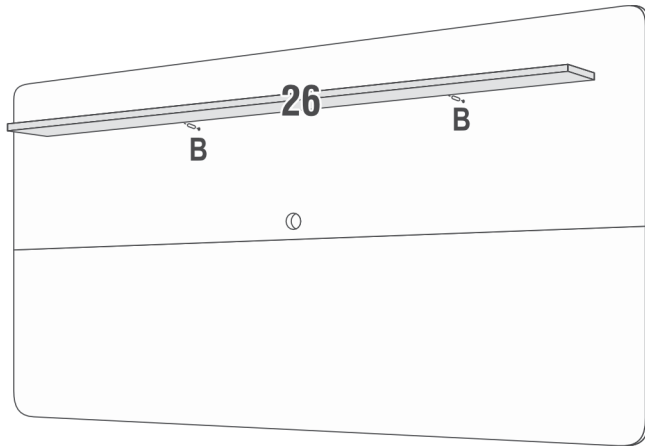

B = 2 

PASSO 04 PASSE COLA (J) NA PEÇA 24 E PARAFUSE-A UNINDO COM A PEÇA 26 COM PARAFUSO 7x60 (G).
STEP 04 APPLY GLUE (J) TO PART 24 AND ATTACH IT TO PART 26 WITH 7x60 SCREWS (G).
 PASO 04 APLIQUE PEGAMENTO (J) A LA PARTE 24 Y FÍJELA A LA PARTE 26 CON TORNILLOS 7x60 (G).

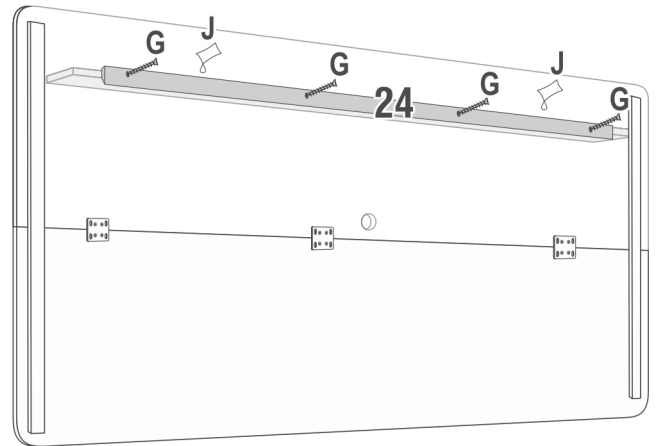

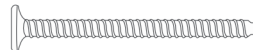
G = 4 

J = 1 

PASSO 05 INSTALE A LUMINÁRIA.
STEP 05 INSTALL THE LED LIGHT.
 PASO 05 INSTALE LAS LUCES LED.

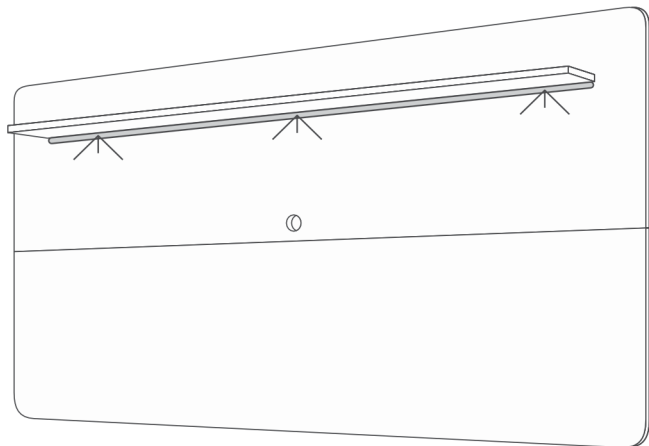

PASSO 06 PARAFUSE A PEÇA 25 NA PAREDE COM BUCHA 10 mm (A) E PARAFUSO 7x80 (H).
STEP 06 SCREW PART 25 TO THE WALL BY USING 10mm ANCHORS (A) AND 7x80 SCREWS (H).
 PASO 06 ATORNILLE LA PARTE 25 A LA PARED CON TACOS 10 mm (A) Y TORNILLOS 7x80 (H).

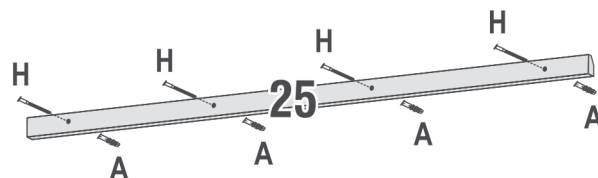

PASSO 07 PENDURE O PAINEL, COLOQUE O SUPORTE TV COM AS RESPECTIVAS FERRAGENS.
STEP 07 HANG THE PANEL ON THE WALL AND FASTEN THE TV RACK WITH ITS HARDWARE.
 PASO 07 CUELGUE EL PANEL A LA PARED Y ATORNILLE EL SOPORTE DE TV CON SUS HERRAJES.

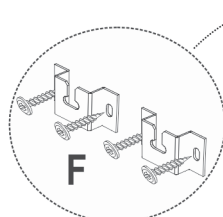

SIGA AS INSTRUÇÕES QUE SE ENCONTRAM DENTRO DO KIT DO SUPORTE.
OBEY THE INSTRUCTIONS PROVIDED IN THE TV RACK KIT.
 SIGA LAS INSTRUCCIONES DEL JUEGO DE SOPORTE DE TV.

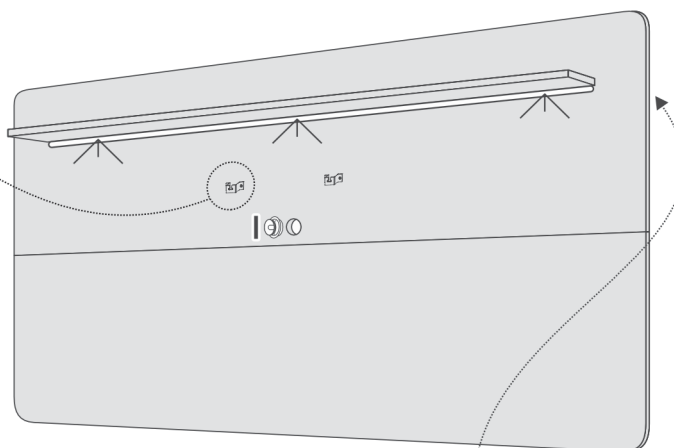

AO FIXAR O SUPORTE NA TV, PARAFUSOS PODEM SOBRAR, DEPENDENDO DO TAMANHO DA TV.
WHEN FASTENING THE TV RACK, SOME SCREWS MAY BE LEFT, DEPENDING ON THE TV SIZE.
 AL FIJAR EL SOPORTE DE TV, ALGUNOS TORNILLOS PUEDEN SOBRAR, DEPENDIENDO DEL TAMAÑO DE LA TV.



DETALHE ENCAIXE DAS
 RÉGUAS MACHO (MÓVEL)
 E FÊMEA (PAREDE).
**MALE (PANEL) AND
 FEMALE (WALL)
 STRIPS FITTING DETAIL.**
 DETALLE DE ENCAJE DE
 LOS LISTONES MACHO (PANEL)
 Y HEMBRA (PARED).

