

MANUAL DE MONTAGEM

ASSEMBLY INSTRUCTIONS

INSTRUCCIONES DE MONTAJE

NOTICE DE MONTAGE

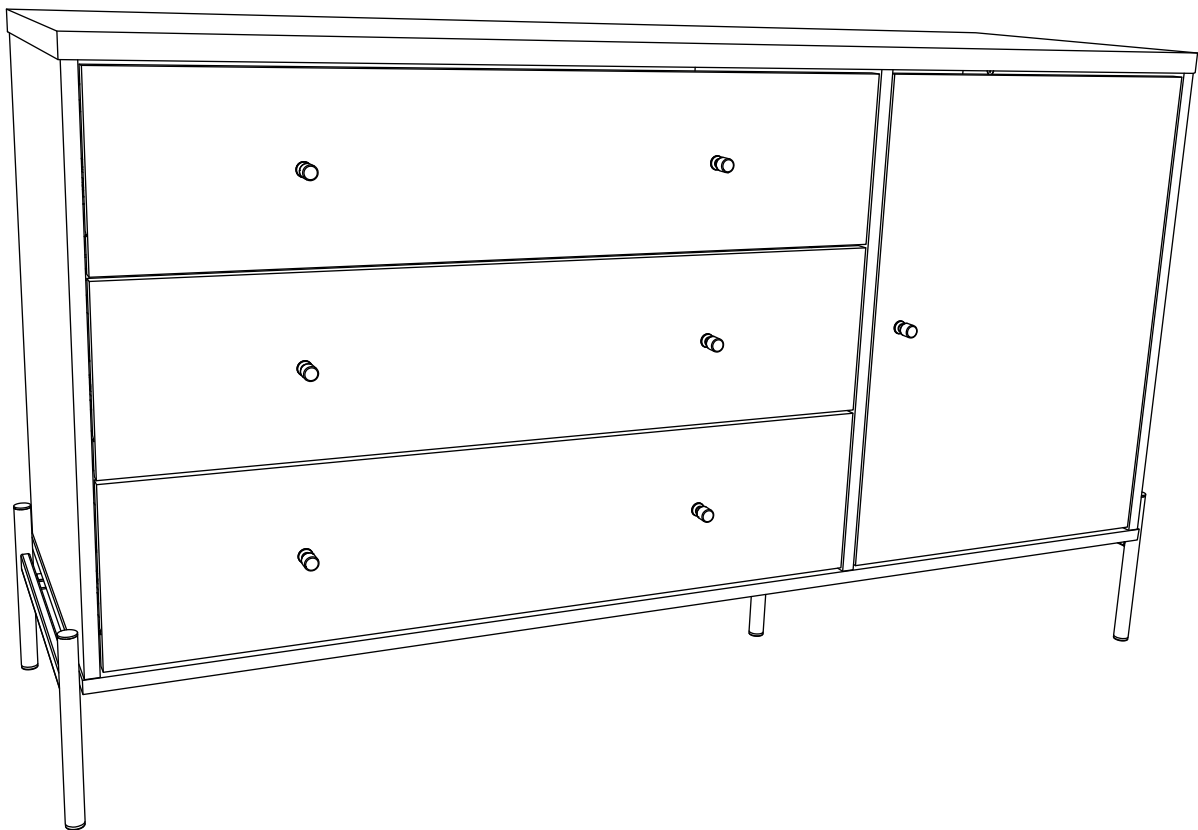

COD:61600

COD:62000

REV. 04 - 17/05/23

OBSERVAÇÕES IMPORTANTES IMPORTANT REMARKS OBSERVACIONES IMPORTANTES REMARQUES IMPORTANTES



Nunca escale ou se apoie sobre o móvel. Você pode sofrer graves acidentes.

Never climb or lean on the furniture. You may suffer serious accidents.

Nunca escale o apoye sobre el mobiliario. Usted puede sufrir graves accidentes.

Ne montez jamais sur le meuble. Vous pourriez subir un grave accident.



Movimente o móvel com cuidado, sem arrastar. Peça ajuda a outra pessoa para fazê-lo.

Move the piece carefully, don't drag it. Ask for someone else's help to do so.

Mover la unidad con cuidado, sin arrastar. Pedir ayuda da otra persona para moverlo.

Déplacez les meubles avec précaution sans le faire glisser. Demandez a quelqu'un de vous aider à le faire.



Limpe com um pano limpo e umedecido em água e sabão neutro. Não utilizar produtos químicos e abrasivos.

Wipe clean using a damp cloth and a mild cleaner. Don't use abrasive and chemical products.

Limpie con un paño limpio humedecido con agua y jabón neutro. No utilice productos químicos y abrasivos.

Nettoyez avec un chiffon propre imbibé avec d'eau et de savon doux. N'utilisez pas de produits chimiques et abrasifs.

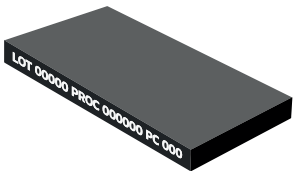

Observe os números impressos nas bordas para identificar as peças.

Identify the parts by observing the number printed on their edges.

Identifique las piezas observando el numero impreso en sus bordes.

Notez les numéros imprimés sur les bords pour identifier les pièces.

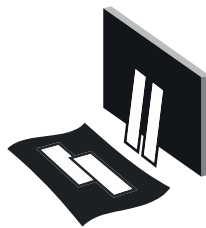

Utilize a embalagem para forrar a área de montagem e separar todas as peças.

Use the packaging to cover the assembly area and separate all parts.

Utilice el embalaje para cubrir la area de montaje y separe las piezas.

Couvrez la zone d'assemblage avec l'emballage pour séparer le pièces.



Não colocar objetos em alta temperatura diretamente sobre superfícies de vidro.

Do not place high-temperature objects directly on glass surfaces.

No coloque objetos de alta temperatura directamente sobre superficies de vidro.

Ne placez pas d'objets à haute température directement sur les surfaces en verre.

ACESSÓRIOS HARDWARE HERRAJES ACCESSOIRES

Identifique e separe os acessórios utilizados. Em cada embalagem, uma etiqueta identifica as peças e onde utilizá-las.

Identify and separate the hardware used in the assembly. There's a label on each package identifying the parts and where to use them.

Identifique y separete los accesorios utilizados en el montaje. Observe la etiqueta en cada paquete para saber donde montar.

Identifiez et séparez les accessoires à être utilisés. Dans chaque emballage il y a une étiquette pour identifier les pièces et où les utiliser.

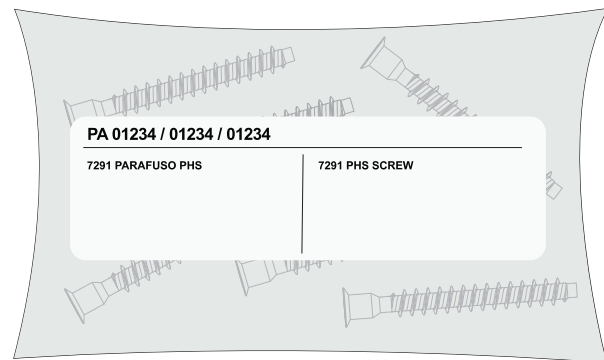

PA62000 - 1389 mm









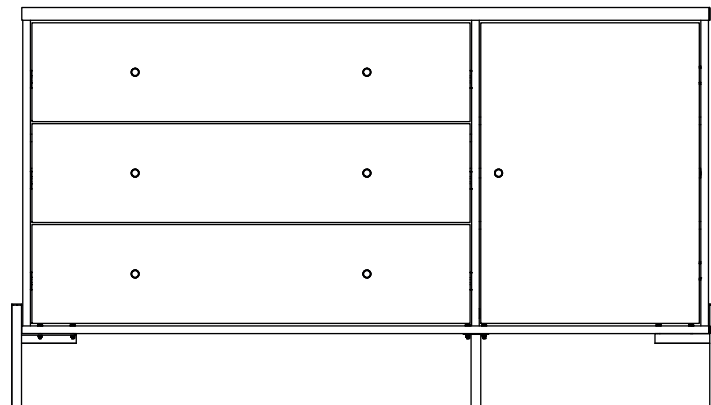

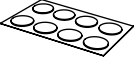



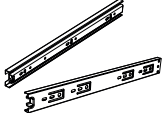

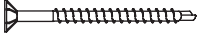
L:1389mm A:791mm P:445mm

W:54.69in H:31.15in D:17.52in

L:1389mm A:791mm P:445mm

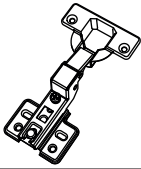
L:1389mm H:791mm P:445mm

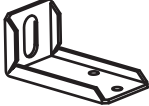

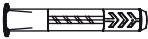
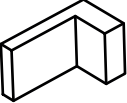
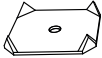
<p>A ADESIVO STICKER ADHESIVO AUTOCOLLANT (15X)</p> 	<p>B COD. 0357 8.0 x 8.0 (46X)</p> 	<p>C COD. 10063 (24X)</p> 	<p>D COD. 1668 6.0 x 30 (46X)</p> 	<p>E COD. 2661 (03X)</p> 
<p>F COD. 0599 (24X)</p> 	<p>G COD. 1533 4.0 x 14 (24X)</p> 	<p>H COD. 0715 4.5 x 50 (06X)</p> 	<p>I COD. 3187 M4 x 20 (07X)</p> 	<p>J COD. 9842 M4 x 25 (12X)</p> 
<p>K SAPATA PLASTIC STOPPER ALMOHADILLA PLASTICO BOUCHON PLASTIQUE (05X)</p> 	<p>L COD. 13518 (12X)</p> 	<p>M PUXADOR DOOR HANDLE MANIJA POIGNÉE (07X)</p> 	<p>N PERFIL H PROFILE H PERFIL H POUTRE EN H (01X)</p> 	<p>O COD. 8903 (02X)</p> 
<p>P COD. 7519 4.5 X 16 (12X)</p> 	<p>Q COD. 3934 (01X)</p> 	<p>R COD. 3557 4.0 X 14 (03X)</p> 	<p>S COD. 6244 6.0 X 65 (01X)</p> 	<p>T COD. 2088 UX8 (01X)</p> 
<p>U COD. 5681 (01X)</p> 	<p>V COD. 0342 (06X)</p> 			

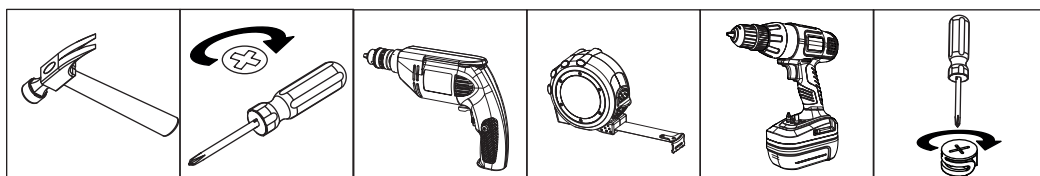



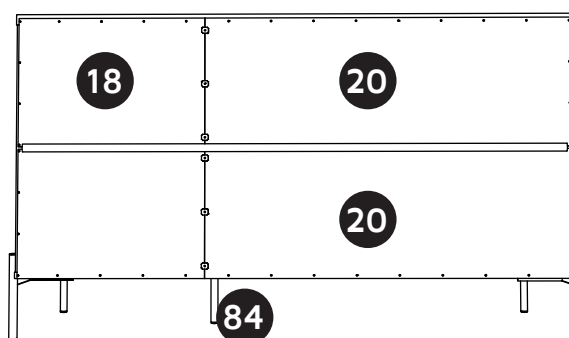
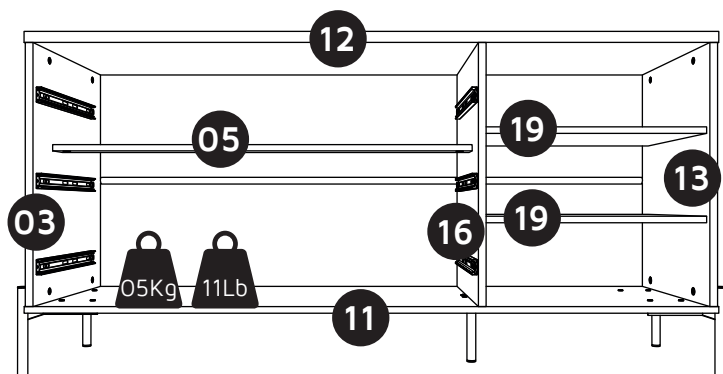
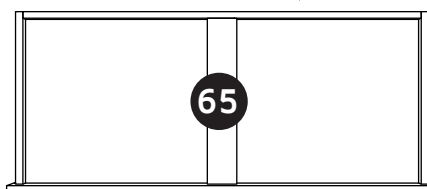
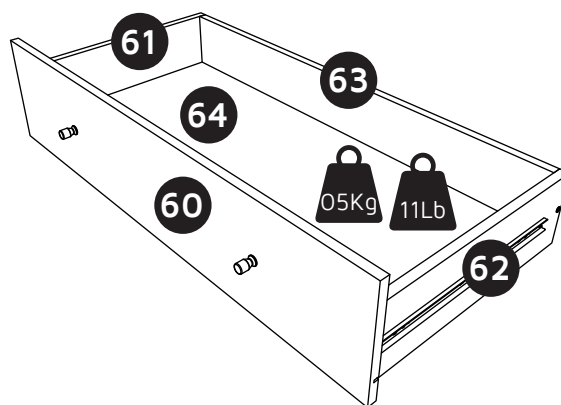
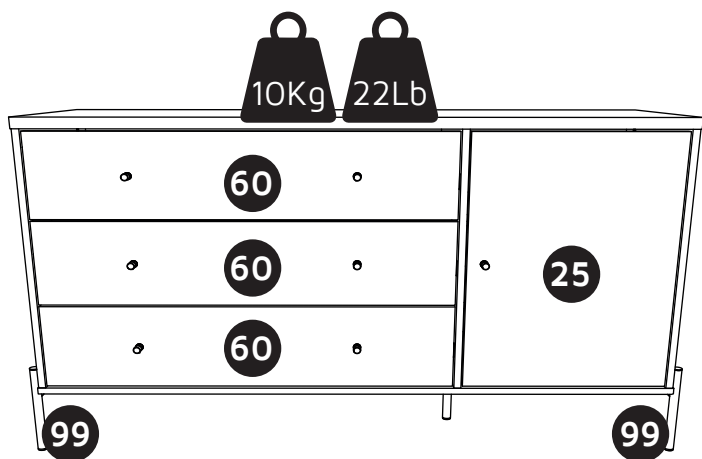

DESCRIÇÃO/ DESCRIPTION/ DESCRIPCIÓN/ DESCRIPTION

CÓD:62000						
PEÇA PART PIEZA	QUANTIDADE QUANTITY CANTIDAD	DESCRIÇÃO	DESCRIPTION	DESCRIPCIÓN	DESCRIPTION	CAIXA BOX CAJA BOÎTE
03	01	LATERAL ESQUERDA	LEFT SIDE	LATERAL IZQUIERDA	CÔTÉ GAUCHE	01
05	01	TRAVESSA INTERNA	INNER CROSSPIECE	TRAVESAÑO INTERNO	ENTREJAMBE INTERNE	01
11	01	BASE	BASE	BASE	BASE	01
12	01	TAMPO	TOP PANEL	PANEL SUPERIOR	PLATEAU	01
13	01	LATERAL DIREITA	RIGHT SIDE	LATERAL DERECHA	CÔTÉ DROITE	01
16	01	DIVISÓRIA	DIVIDER	DIVISION	DIVISEUR	01
18	02	FUNDO	BACKPLATE	FONDO	FOND	01
19	02	PRATELEIRA	TOP SHELF	ESTANTE	ÉTAGÈRE	01
20	02	FUNDO	BACKPLATE	FONDO	FOND	01
25	01	PORTA	DOOR	PUERTA	PORTE	01
60	03	FRENTE GAVETA	DRAWER FRONT	FRENTE DEL CAJÓN	FAÇADE DE TIROIR	01
61	03	LATERAL GAVETA ESQ.	LEFT DRAWER SIDE	CAJÓN LATERAL IZQ.	CÔTÉ DE TIROIR	01
62	03	LATERAL GAVETA DIR.	RIGHT DRAWER SIDE	CAJÓN LATERAL DER.	CÔTÉ DE TIROIR	01
63	03	CONTRA FUNDO	DRAWER BACK PANEL	CAJÓN INFERIOR	DERRIÈRE	01
64	03	FUNDO GAVETA	DRAWER BOTTOM	FONDO DEL CAJÓN	FOND DE TIROIR	01
65	03	TRAVESSA GAVETA	DRAWER CROSSPIECE	TRAVESAÑO CAJÓN	BARREAU	01
84	01	BASE AÇO CENTRAL	CENTER STEEL BASE	BASE ACERO CENTRAL	BASE CENTRALE ACIER	02
99	02	BASE DE AÇO	STEEL BASE	BASE DE ACERO	BASE EN ACIER	02

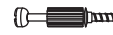

01

D COD. 1668 	F COD. 0599 	I COD. 3187 	M 	O COD. 8903 	P COD. 7519 
--	--	---	---	--	--

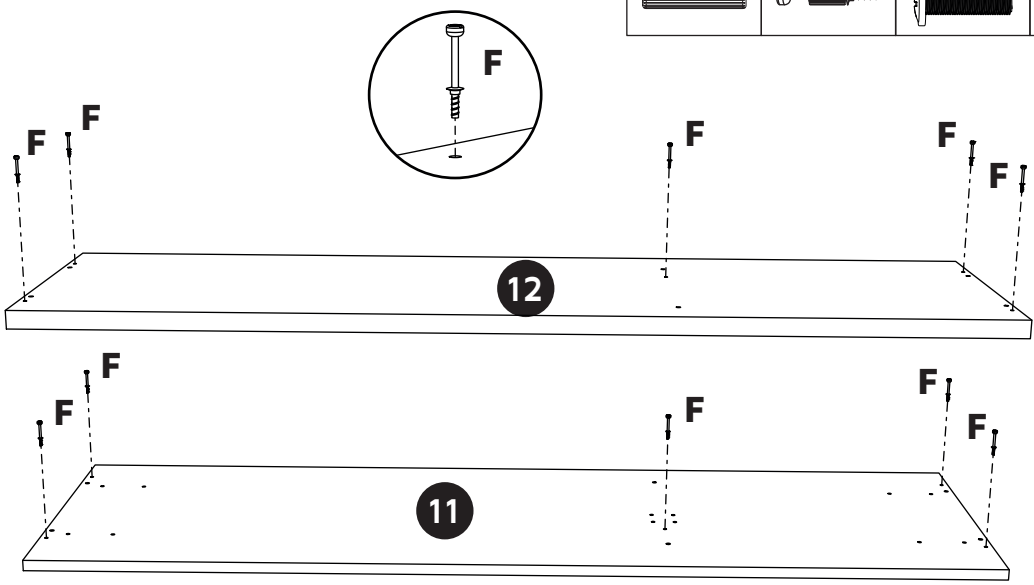

PASSO 01
Parafusar minifix 5x**0599**
na base **11** e tampo **12**.

STEP 01
Screw minifix 5x**0599** on
base **11** and top board **12**.

PASO 01
Atornillar el minifix 5x**0599**
en la base **11** y la cubierta **12**.

ÉTAPE 01
Vissez le minifix 5x**0599** dans
la base **11** et plateau **12**.

02

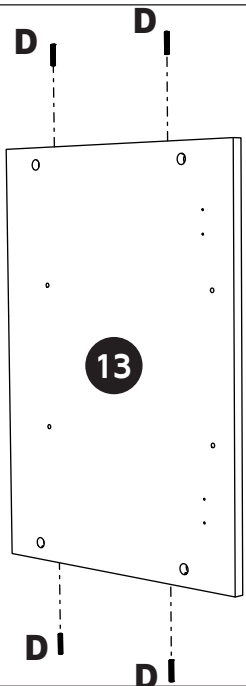

PASSO 02
Encaixar cavilhas 4x**1668** na
lateral direita **13**/ prateleira **19**,
2x**1668** na travessa interna **05**.

STEP 02
Insert dowels 4x**1668** on the
right side **13**/ top shelf **19**,
2x**1668** on the liner crosspiece **05**.

PASSO 02
Clavijas de ajuste 4x**1668** en el
lateral derecha **13**/ estante **19**,
2x**1668** en el travesaño interno **05**.

ÉTAPE 02
Insérez les chevilles 4x**1668** et
côté droit **13**/ étagère **19**,
2x**1668** et entrejambe interne **05**.

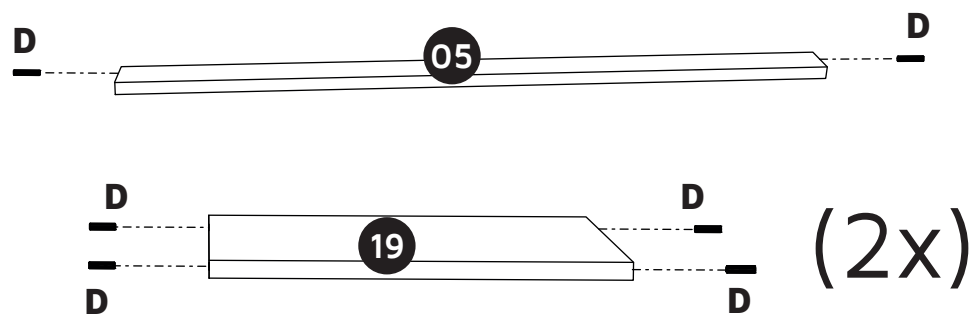

03

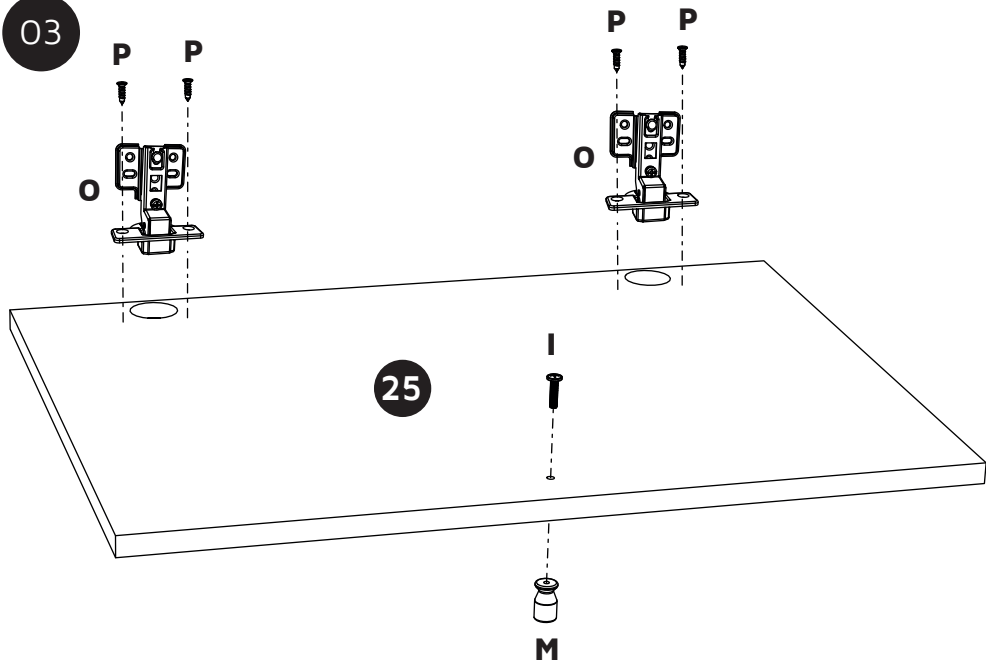

PASSO 03
Encaixar dobradiças 2x**8903**
e parafusar 4x**7519**. Montar
puxador 1x**3187** na porta **25**.

STEP 03
Attach the hinges 2x**8903** and
screw 4x**7519**. Attach door
handle 1x**3187** at the door **25**.

PASO 03
Montar las bisagras 2x**8903** y
atornillar 4x**7519**. Montar la
manija 1x**3187** en la puerta **25**.

ÉTAPE 03
Insérez les charnières 2x**8903** et
vissez 4x**7519**. Insérez poignée
1x**3187** et porte **25**.

04

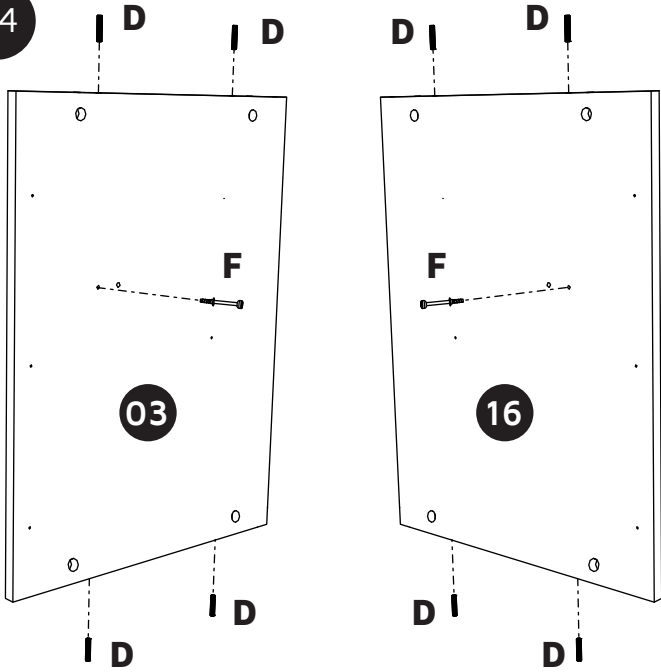

D COD. 1668	E COD. 2661	G COD. 1533

PASSO 04
Encaixar cavilhas 4x**1668** e parafusar minifix 1x**0599** na lateral esquerda **03/** divisória **16**.

STEP 04
Insert dowels 4x**1668** and screw minifix 1x**0599** on the left side **03/** divider **16**.

PASO 04
Clavijas de ajuste 4x**1668** y atornillar el minifix 1x**0599** en la lateral izquierda **03/** division **16**.

ÉTAPE 04
Insérez les chevilles 4x**1668** et vissez le minifix 1x**0599** sur les côté gauche **03/** diviseur **16**.

05

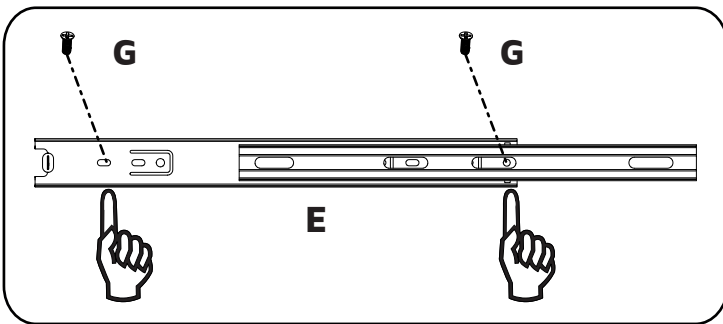

PASSO 05
Parafusar 6x**1533** as corredeças 3x**2661** na lateral esquerda **03/** divisória **16**.

STEP 05
Screw 6x**1533** the slides 3x**2661** on the left side **03/** divider **16**.

PASO 05
Atornillar 6x**1533** las correderas 3x**2661** en la lateral izquierda **03/** division **16**.

ÉTAPE 05
Vissez 6x**1533** les curseurs 3x**2661** sur les côté gauche **03/** diviseur **16**.

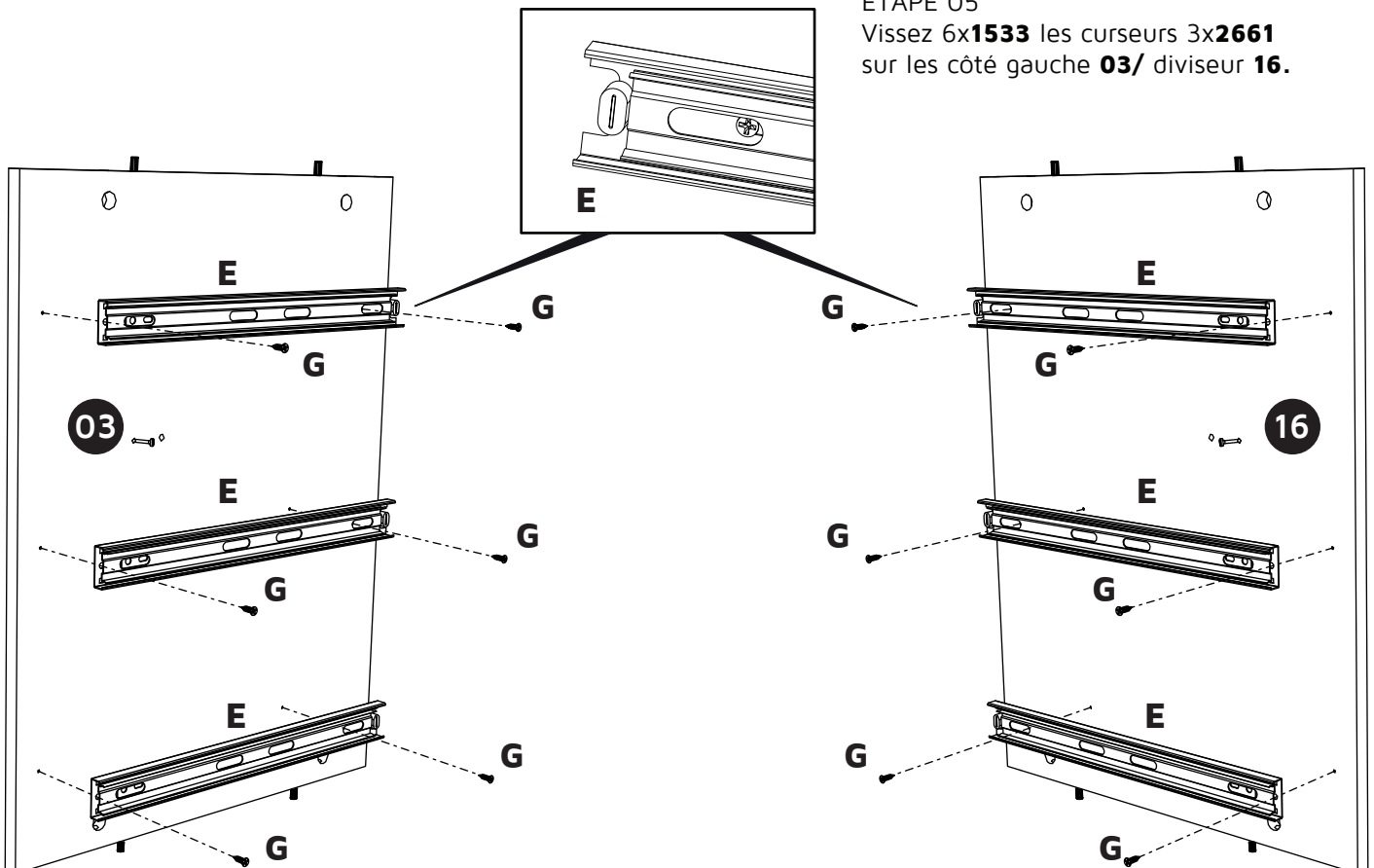

06

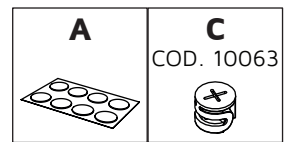

PASSO 06

Encaixar lateral esquerda **03** e parafusar castanhas 2x**10063**.

STEP 06

Attach left side **03** and screw nuts 2x**10063**.

PASO 06

Montar la lateral izquierda **03** y atornillar las tuercas 2x**10063**.

ÉTAPE 06

Insérez le côté gauche **03** et vissez le brunette 2x**10063**.

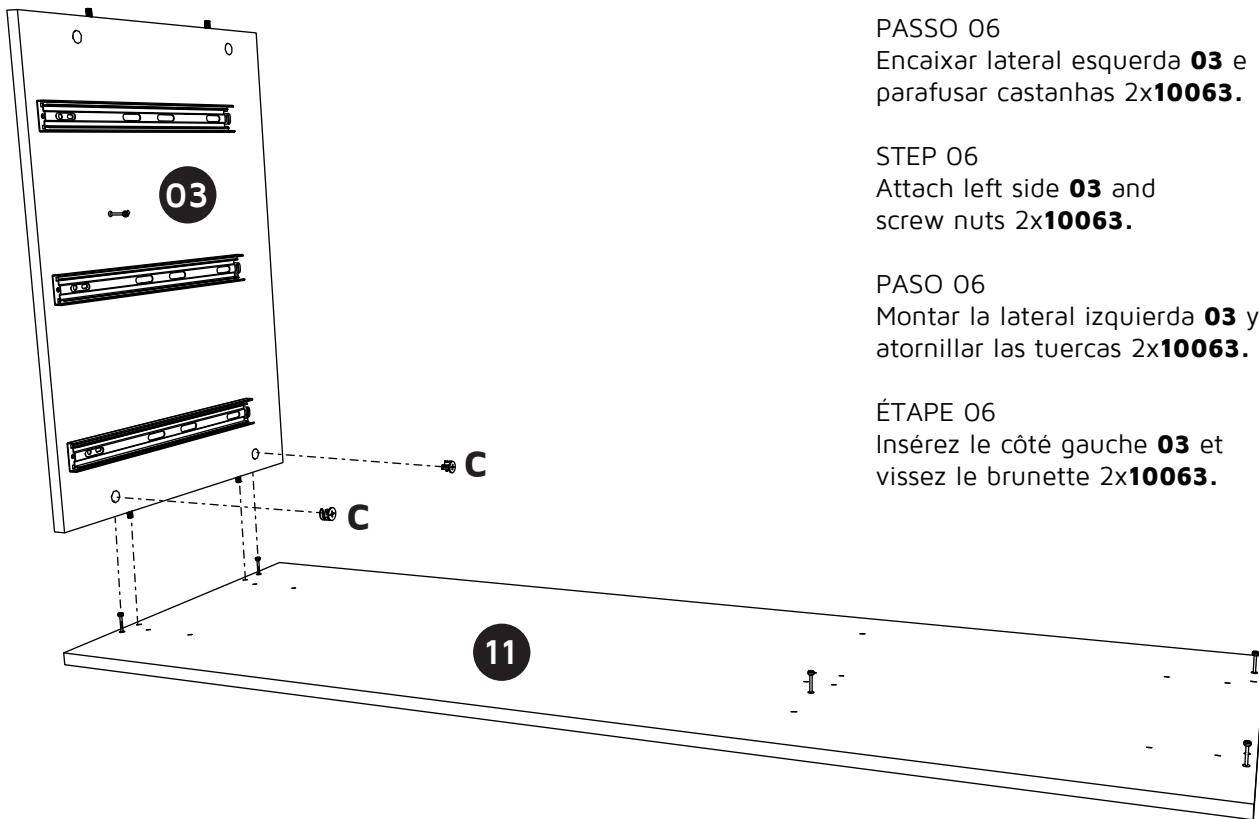

07

PASSO 07

Encaixar travessa interna **05**, divisória **16**, parafusar castanhas 3x**10063** e colar **1** adesivo.

STEP 07

Attach the liner crosspiece **05**, divider **16**, screw nuts 3x**10063** and place **1** sticker.

PASO 07

Montar el travesaño interno **05**, división **16**, atornillar las tuercas 3x**10063** y pegar **1** adhesivo.

ÉTAPE 07

Insérez le entrejambe interne **05**, diviseur **16**, vissez le brunette 3x**10063** et collez **1** l'adhésif.

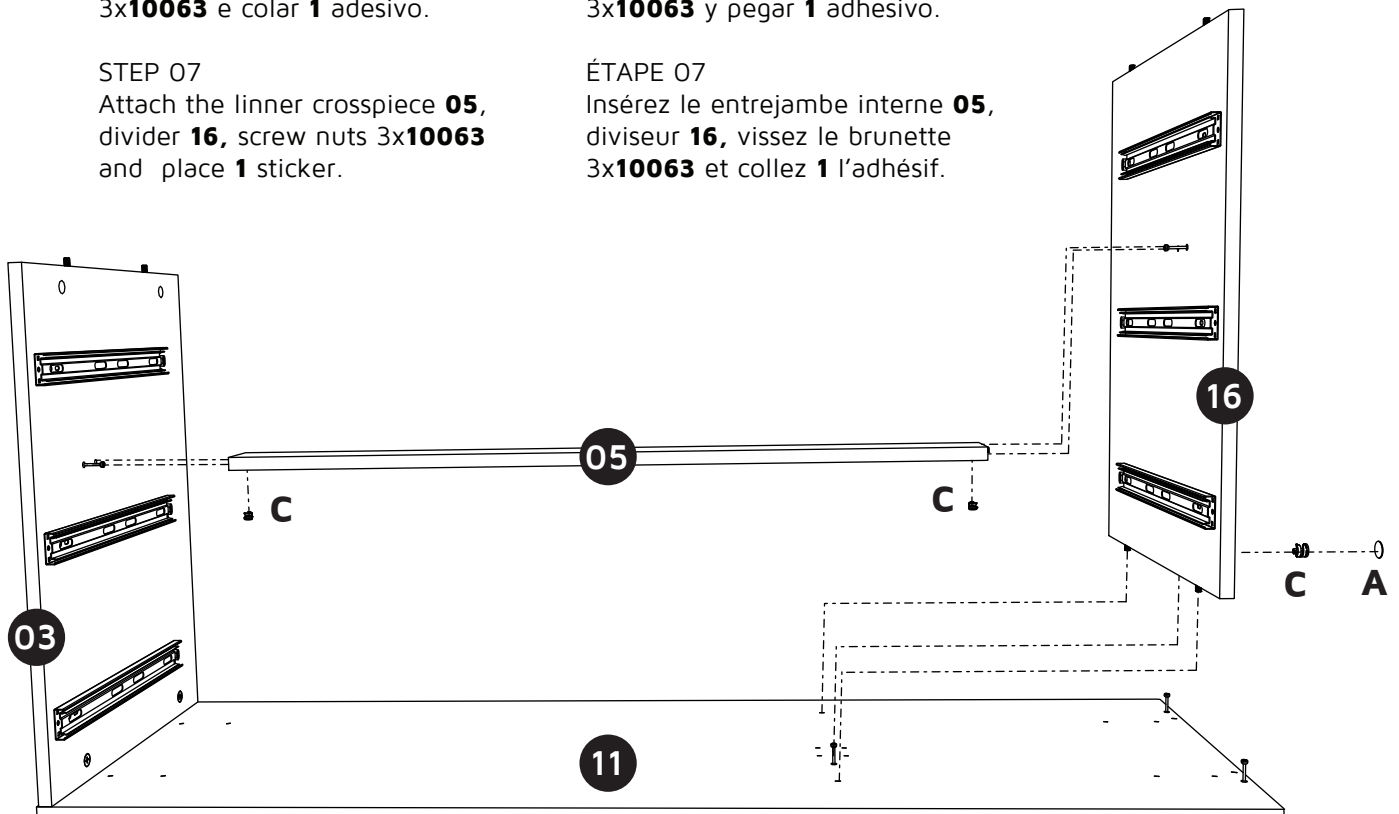

08

PASSO 08
Encaixar prateleiras **19**, lateral direita **13**, parafusar castanhas **2x10063** e colar **2** adesivos.

STEP 08
Attach the top shelves **19**, right side **13**, screw nuts **2x10063** and place **2** stickers.

PASO 08
Montar la estante **19**, lateral derecha **13**, atornillar las tuercas **2x10063** y pegar **2** adhesivos.

ÉTAPE 08
Insérez le étagère **19**, côté droite **13**, vissez le brunette **2x10063** et collez **2** l'adhésif.

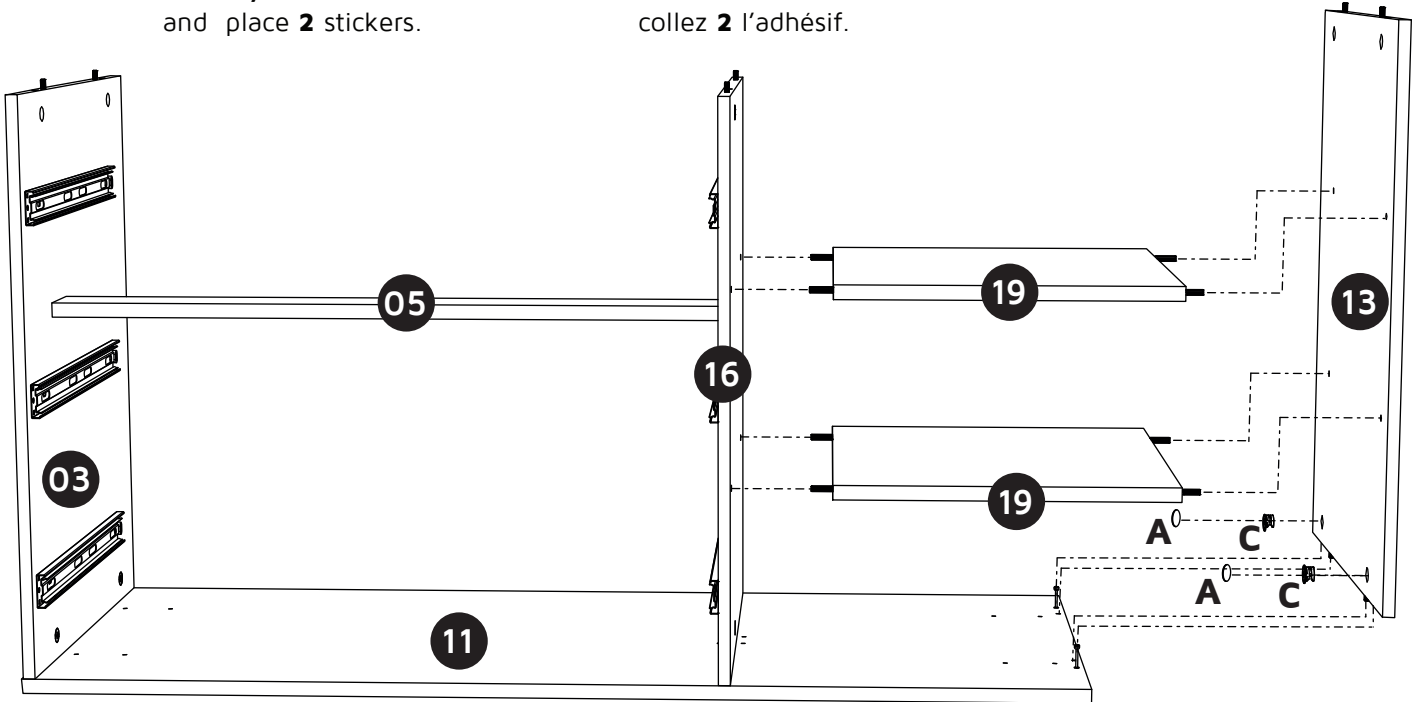
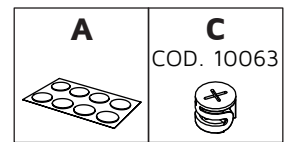

09

PASSO 09
Encaixar tampo **12** e parafusar castanhas **5x10063**.



STEP 09
Attach top panel **12** and screw nuts **5x10063**.

PASO 09
Montar el panel superior **12** y atornillar las tuercas **5x10063**.

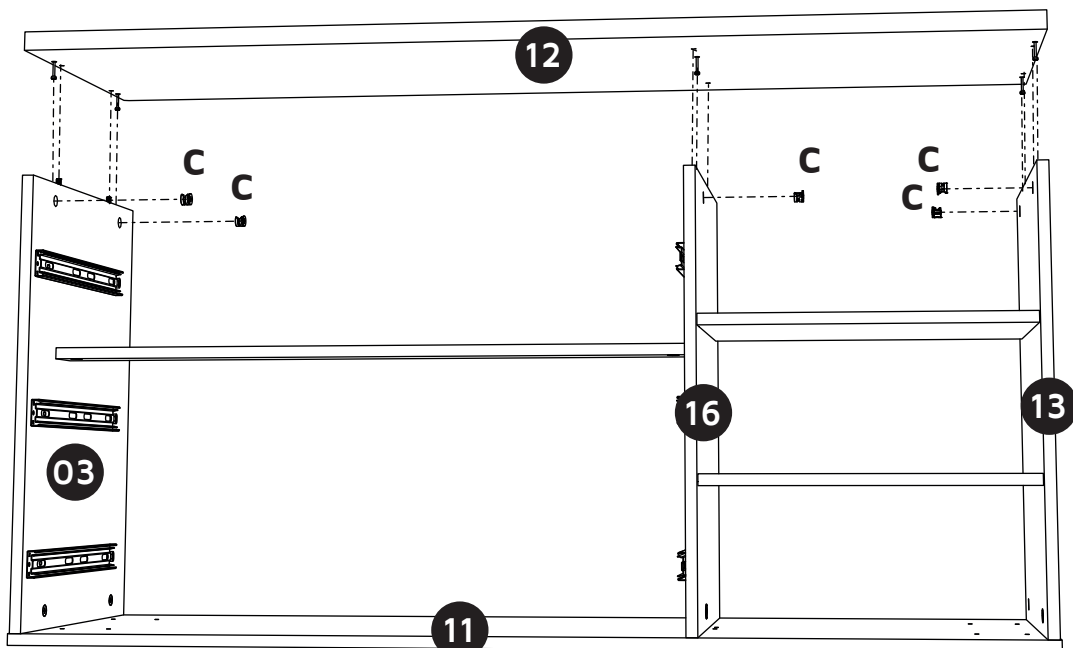
ÉTAPE 09
Insérez le plateau **12** et vissez le brunette **5x10063**.

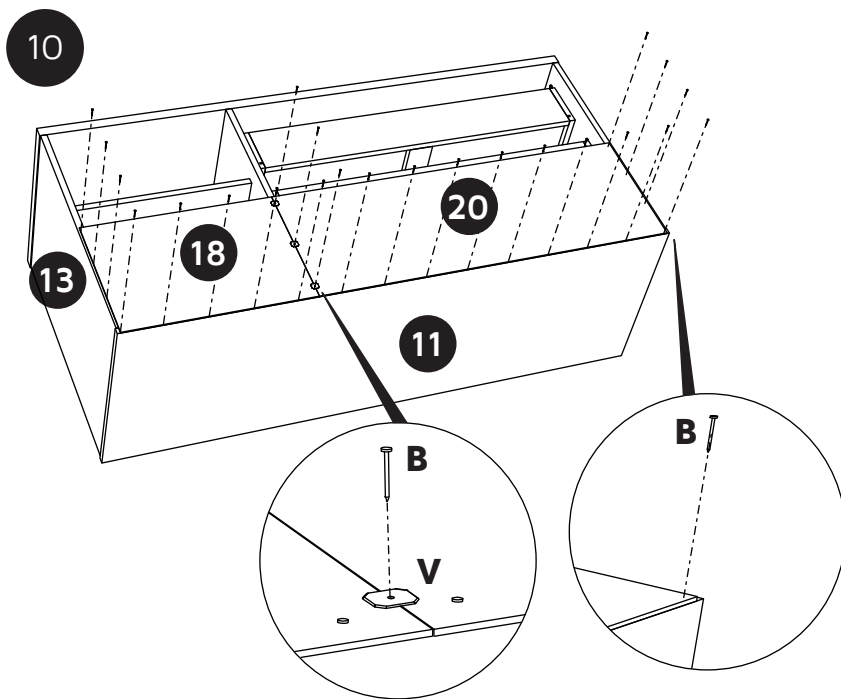

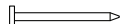
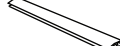

B COD. 0357	N	V COD. 0342
		

PASSO 10
Encaixar fundo **18/20**
e pregar **0342/ 0357**.

STEP 10
Attach backplate **18/20**
and nailing **0342/0357**.

PASO 10
Enganchar el fondo **18/20**
y clavar **0342/0357**.

ÉTAPE 10
Insérez le fond **18/20**
et clouer **0342/0357**.

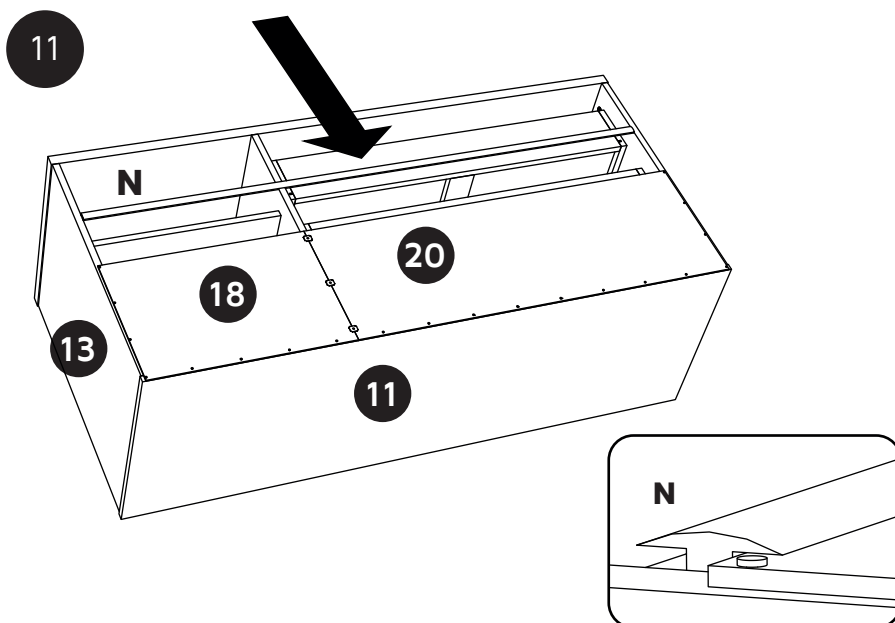

PASSO 11
Encaixar perfil H no fundo **18/20**.

STEP 11
Insert profile H on backplate **18/20**.

PASO 11
Enganchar perfil H en el fondo **18/20**.

ÉTAPE 11
Insérez poutre en H dans clouer **18/20**.

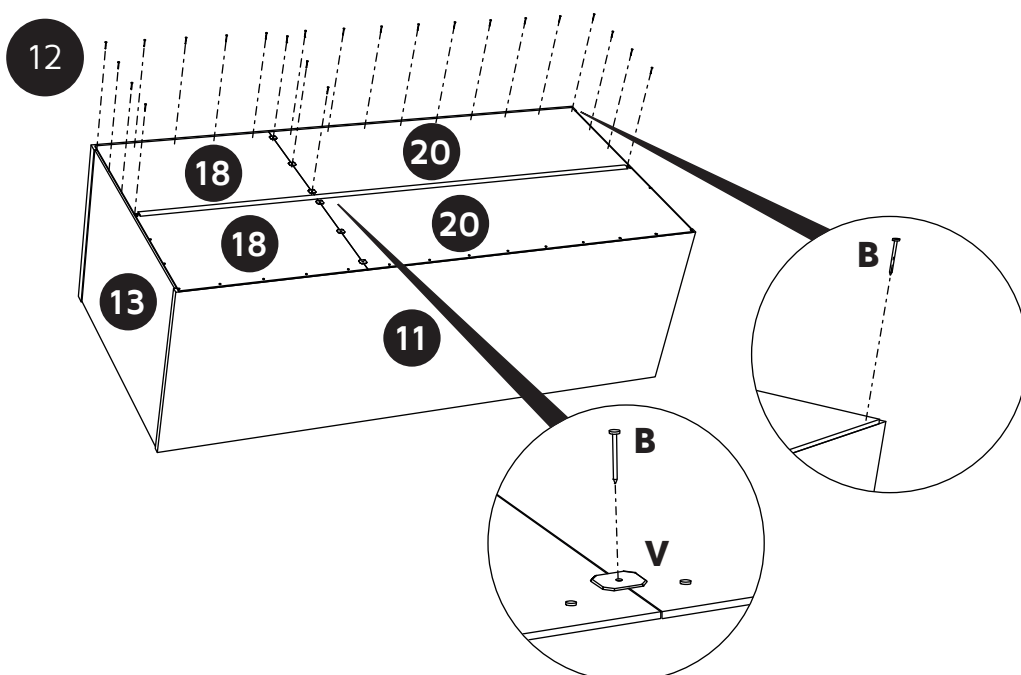

PASSO 12
Encaixar fundo **18/20**
e pregar **0342/ 0357**.

STEP 12
Attach backplate **18/20**
and nailing **0342/0357**.

PASO 12
Enganchar el fondo **18/20**
y clavar **0342/0357**.

ÉTAPE 12
Insérez le fond **18/20**
et clouer **0342/0357**.

13

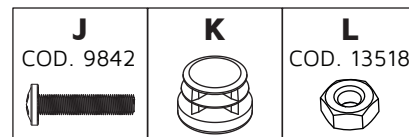
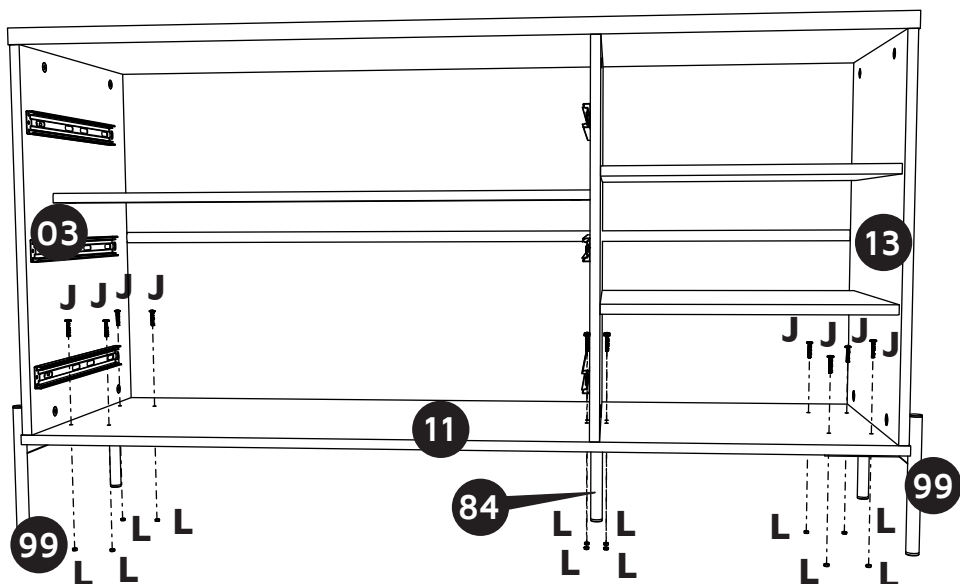

PASSO 13

Parafusar 4x**9842** base de aço **99**/
base central **84** na base **01** e
rosquear as porcas 4x**13518**.

STEP 13

Screw 4x**9842** steel base **99**/
center
steel base **84** on base **01** and
thread the nuts 4x**13518**.

PASO 13

Atornillar 4x**9842** base de acero **99**/
base de acero central **84** en la base **01**
y rolar las tuercas 4x**13518**.

ÉTAPE 13

Vissez 4x**9842** base en acier **99**/
base centrale acier **84** dans la
base **01** et fileter les écrous 4x**13518**.

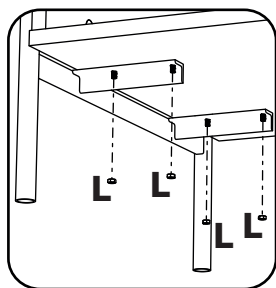
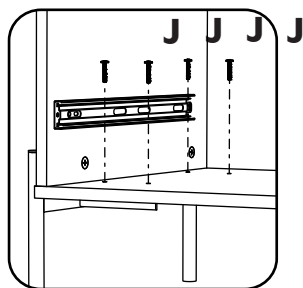

14

PASSO 14

Encaixar sapata plástica na base
de aço **99**/ base aço central **84**.

STEP 14

Insert plastic stopper on steel
base **99**/ center steel base **84**.

PASO 14



Enganchar almohadilla de plástico en la
base de acero **99**/ base de acero central **84**.

ÉTAPE 14

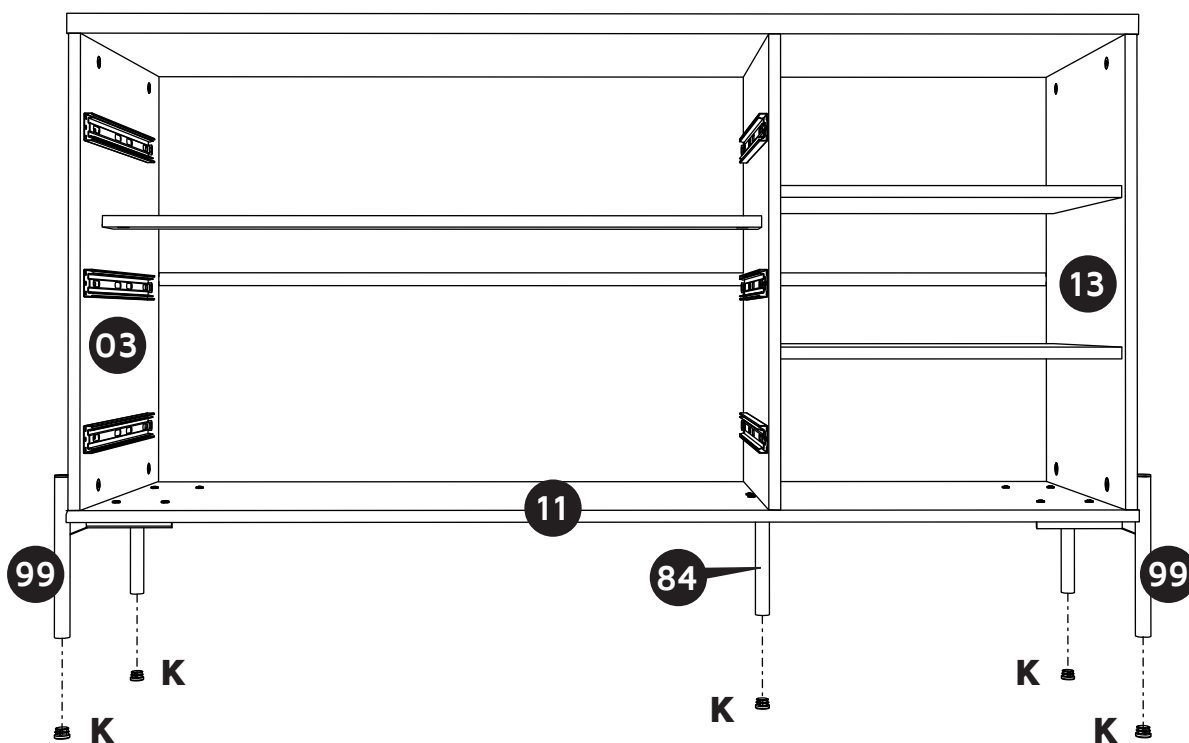
Insérez bouchon plastique dans base
en acier **99**/ base centrale acier **84**.

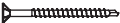

15

D COD. 1668 	E COD. 2661 	G COD. 1533 	H COD. 0715 
---	--	--	--

PASSO 15
Parafusar 4x**1533** as corrediças 2x**2661** nas laterais gaveta esquerda e direita **61/62**.

PASO 15
Atornillar 4x**1533** las corrediças 2x**2661** en los cajóns laterales izquierda y derecha **61/62**.

STEP 15
Screw 4x**1533** the slides 2x**2661** on the left and right drawer side **61/62**.

ÉTAPE 15
Vissez 4x**1533** les curseurs 2x**2661** sur les tiroir latéral gauche et droit **61/62**.

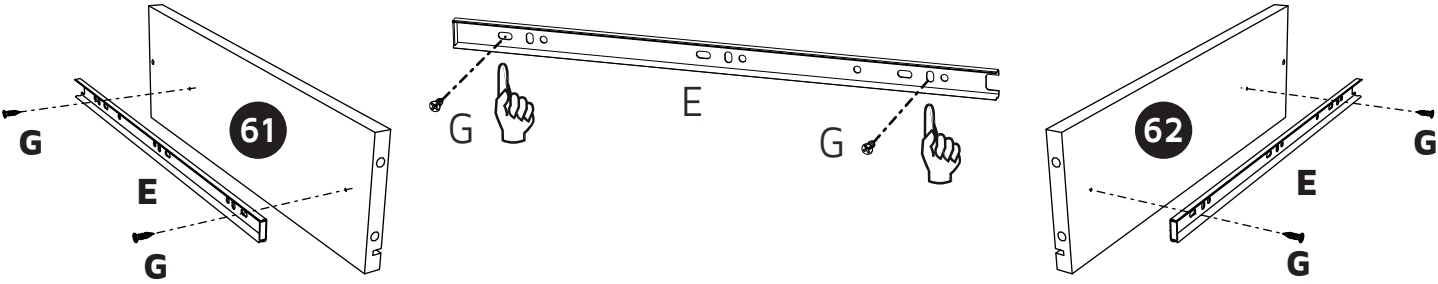

(3x)

16

PASSO 16
Encaixar cavilhas 4x**1668** no contra fundo **66**.
Encaixar laterais gaveta esquerda e direita **61/62** no contra fundo **66** e parafusar 2x**0715**.

PASO 16
Clavijas de ajuste 4x**1668** en cajón inferior **66**.
Montar cajóns laterales izquierda y derecha **61/62** en lo cajón inferior **66** y atornillar 2x**0715**.

STEP 16
Insert dowels 4x**1668** on drawer back panel **66**.
Attach left and right drawer side **61/62** on the drawer back panel **66** and screw 2x**0715**.

ÉTAPE 16
Insérez les chevilles 4x**1668** derrière **66**.
Insérez tiroir latéral gauche et droit **61/62** dans derrière **66** et vissez 2x**0715**.

(3x)

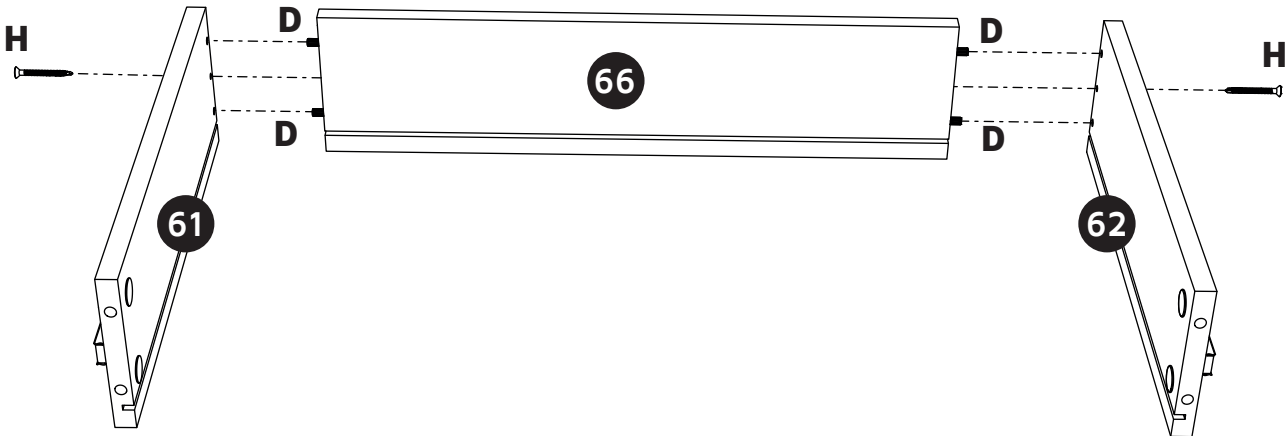

17

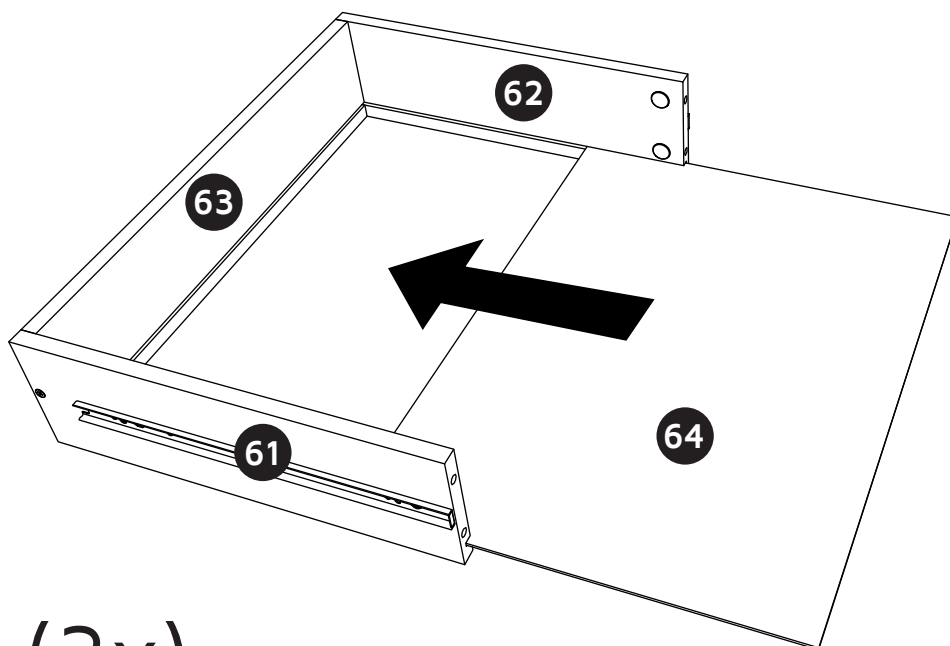
D
COD. 1668

PASSO 17
Encaixar fundo gaveta **64**.

STEP 17
Attach drawer bottom **64**.

PASO 17
Montar fondo del cajon **64**.

ÉTAPE 17
Insérez fond de tiroir **64**.

(3x)

18

PASSO 18
Encaixar cavilhas 4x**1668** na travessa gaveta **65** e montar no contra fundo **63**.

STEP 18
Insert dowels 4x**1668** on drawer crosspiece **65** and attach on drawer back panel **63**.

PASO 18
Clavijas de ajuste 4x**1668** en el travesaño cajón **65** y montar en el cajón inferior **63**.

ÉTAPE 18
Insérez les chevilles 4x**1668** barreau **65** et insérez dans derrière **65**.

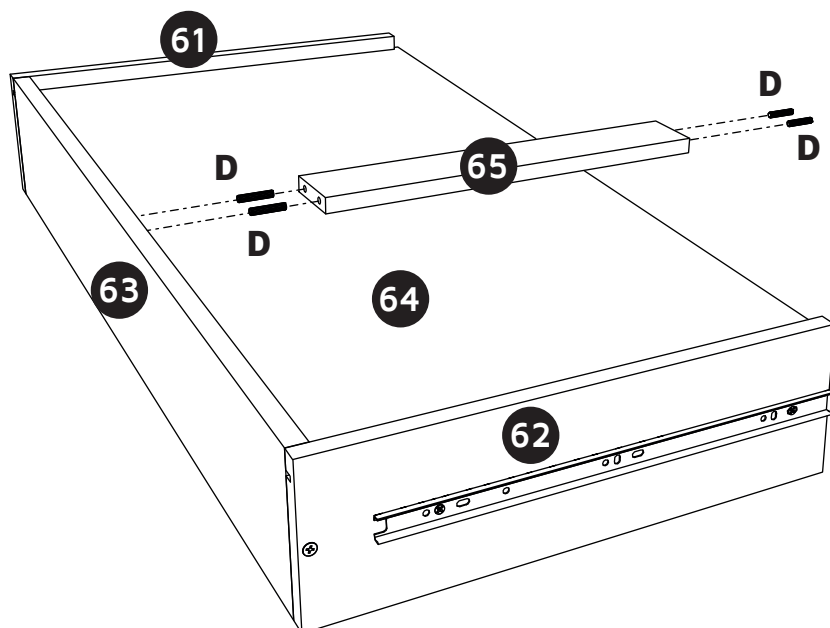

(3x)

19

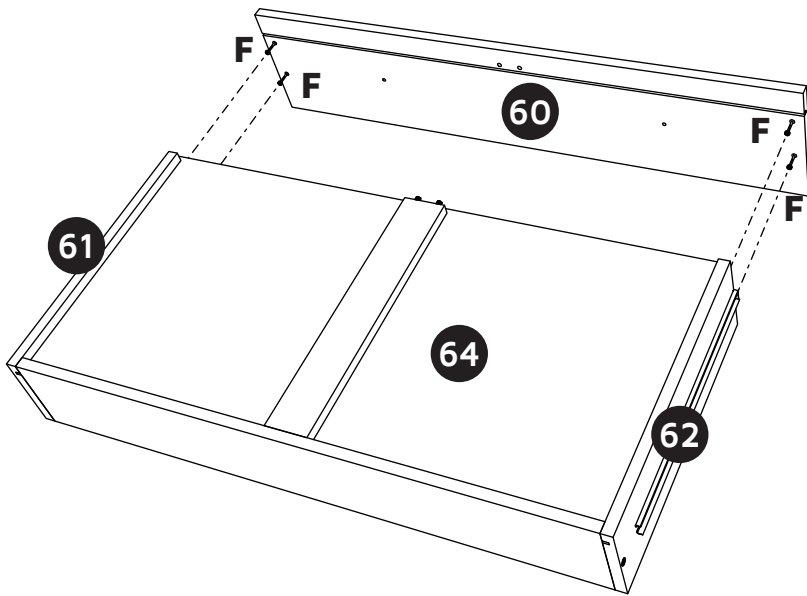
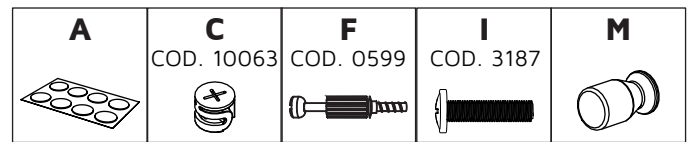

PASSO 19

Parafusar minifix 4x**0599** na frente gaveta **60** e encaixar nas laterais **61/62**.

STEP 19

Screw minifix 4x**0599** on drawer front **60** and attach on sides **61/62**.

PASO 19

Atornillar el minifix 4x**0599** en la frente del cajón **60** y montar en las laterales **61/62**.

ÉTAPE 19

Vissez le minifix 4x**0599** dans la façade de tiroir **60** et insérez dans côtés **61/62**.

(3x)

20

PASSO 20

Encaixar frente gaveta **60**, parafusar castanhas 4x**10063** e colar **4** adesivos. Parafusar 1x**3187** o puxador.

STEP 20

Attach drawer front **60**, screw nuts 4x**10063** and place **4** stickers. Screw 1x**3187** the door handle.

PASO 20

Montar frente del cajón **60**, atornillar las tuercas 4x**10063** y pegar **4** adhesivo. Atornillar 1x**3187** el manija.

ÉTAPE 20

Inseréz façade de tiroir **60**, vissez le brunette 4x**10063** et collez **4** l'adhésif. Vissez 1x**3187** et poignée.

(3x)

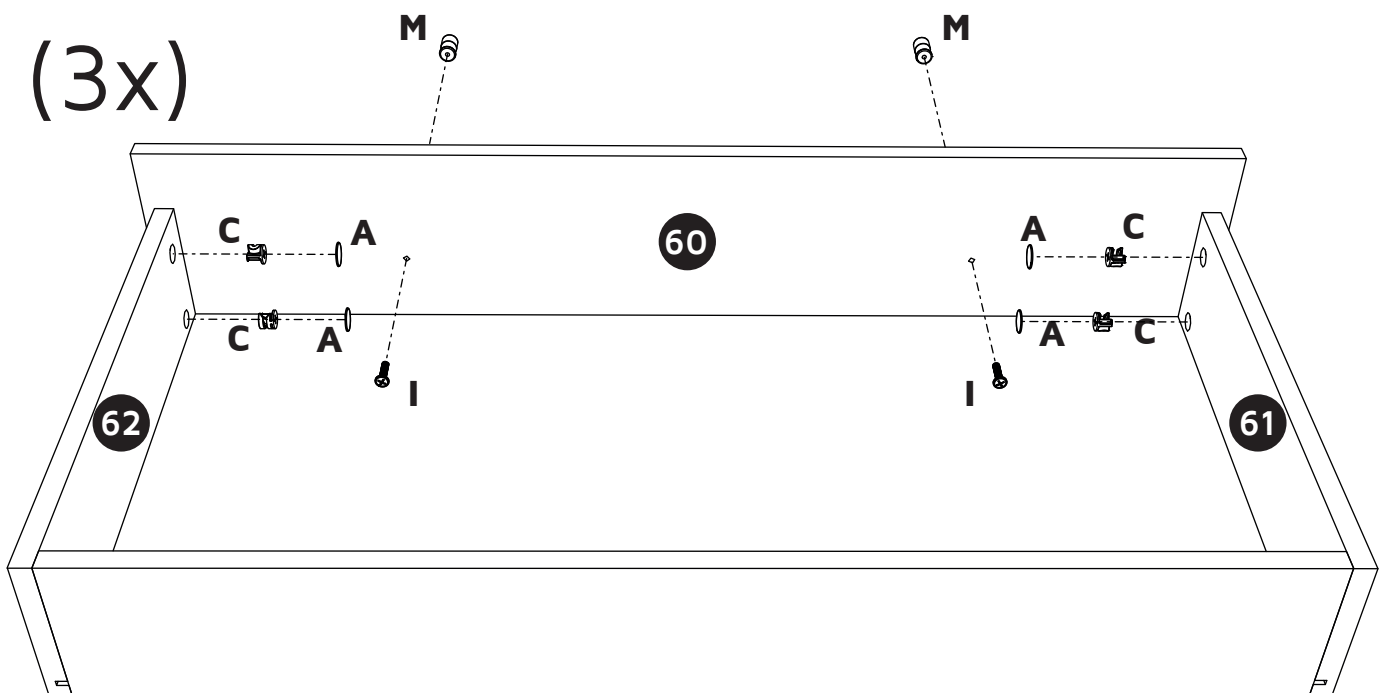

21

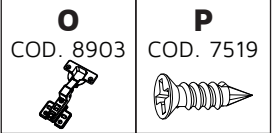

PASSO 21
Encaixar porta **25** e parafusar
8x**7519**.

PASO 21
Montar la puerta **25** y atornillar
8x**7519**.

STEP 21
Attach the door **25** and screw
8x**7519**.

ÉTAPE 21
Insérez porte **25**, vissez
8x**7519**.

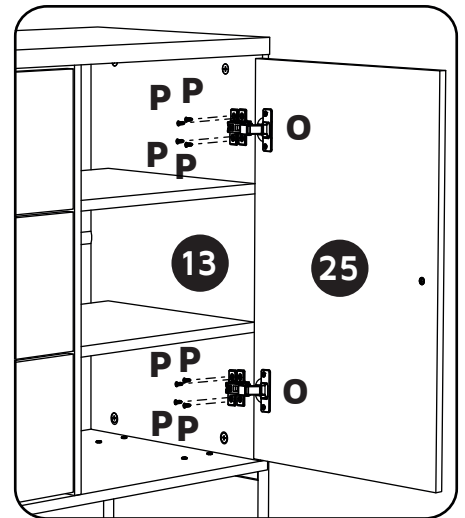

22



Atenção
Attention
Atención
Attention

AJUSTE DAS DOBRADIÇAS
HINGE ADJUSTMENT
AJUSTE DE LAS BISAGRAS
RÉGLAGE DES CHARNIÈRES

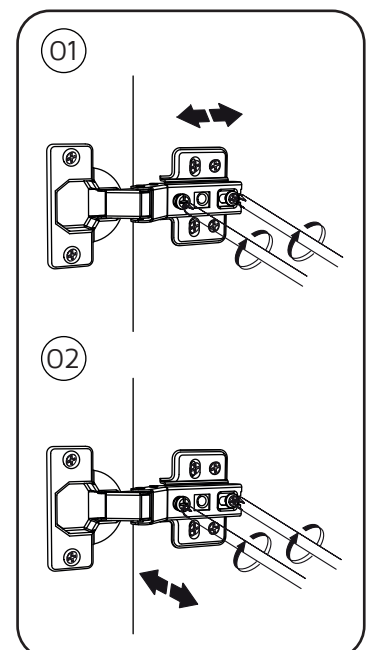
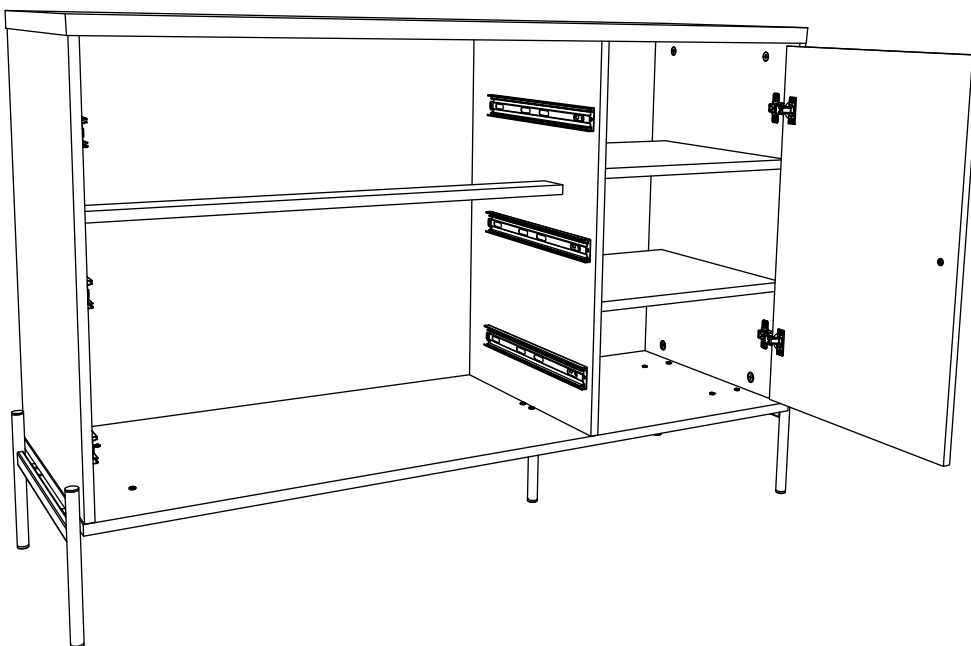

23



Atenção
Attention
Atención
Attention

Q COD. 3934	R COD. 3557	S COD. 6244	T COD. 2088	U COD. 5681

É obrigatório fixar este acessório de segurança.

It's mandatory to fix this safety device.

Es obligatorio adjuntar este accesorio de seguridad.

Il est obligatoire de fixer cet accessoire de sécurité.

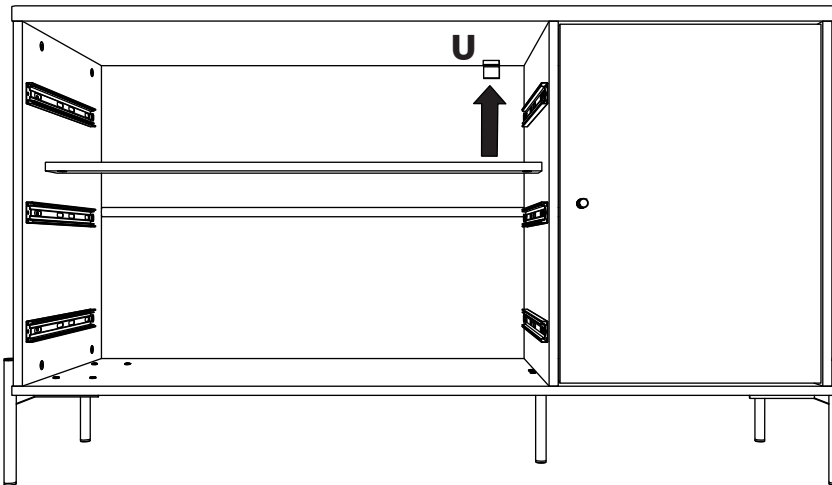
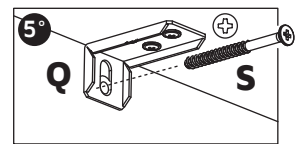
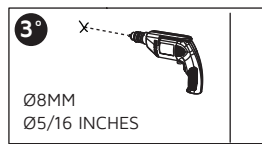
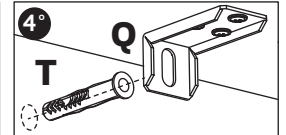
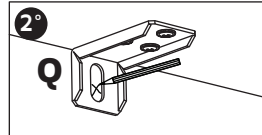
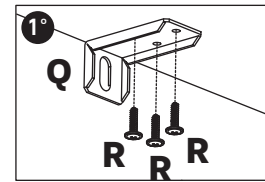

24

