

MANUAL DE MONTAGEM

ASSEMBLY INSTRUCTIONS

INSTRUCCIONES DE MONTAJE

NOTICE DE MONTAGE

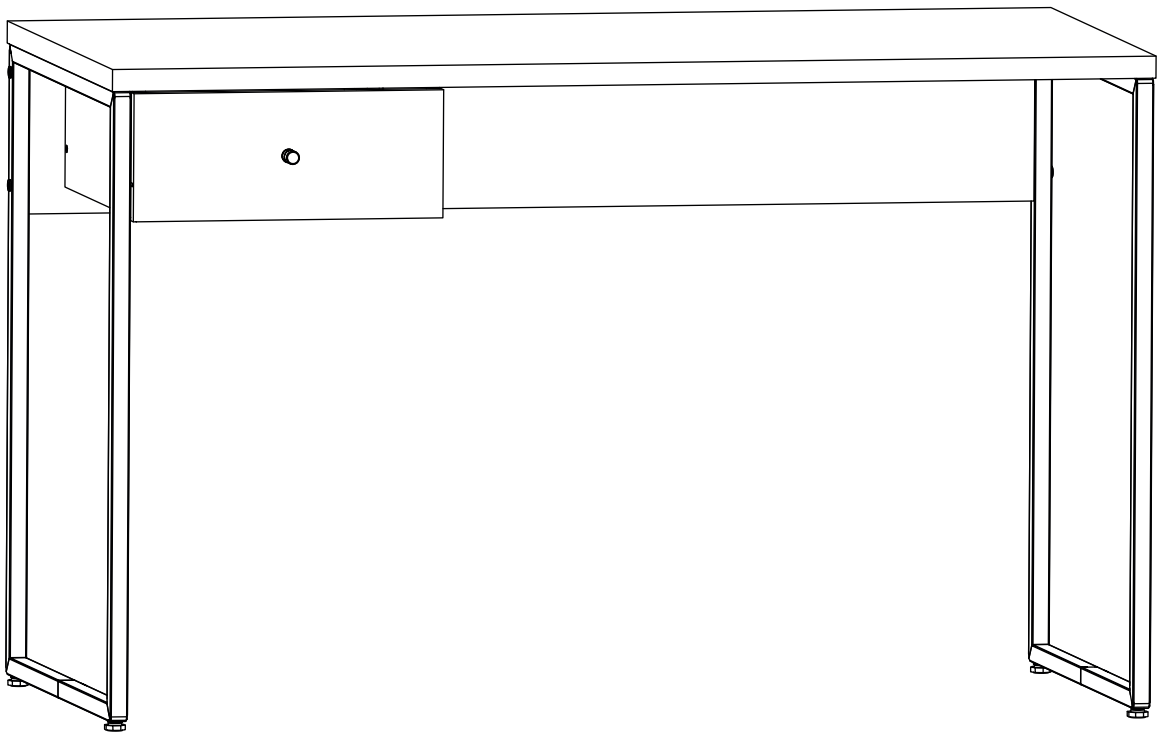

COD: 73300

REV. 00 - 09/10/23

OBSERVAÇÕES IMPORTANTES IMPORTANT REMARKS OBSERVACIONES IMPORTANTES REMARQUES IMPORTANTES



Nunca escale ou se apoie sobre o móvel. Você pode sofrer graves acidentes.

Never climb or lean on the furniture. You may suffer serious accidents.

Nunca escale o apoie sobre el mobiliario. Usted puede sufrir graves accidentes.

Ne montez jamais sur le meuble. Vous pourriez subir un grave accident.

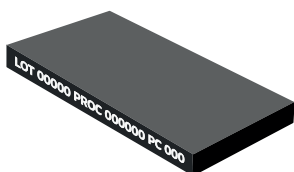

Observe os números impressos nas bordas para identificar as peças.

Identify the parts by observing the number printed on their edges.

Identifique las piezas observando el numero impreso en sus bordes.

Notez les numéros imprimés sur les bords pour identifier les pièces.



Movimente o móvel com cuidado, sem arrastar. Peça ajuda a outra pessoa para fazê-lo.

Move the piece carefully, don't drag it. Ask for someone else's help to do so.

Mover la unidad con cuidado, sin arrastar. Pedir ayuda da otra persona para moverlo.

Déplacez les meubles avec précaution sans le faire glisser. Demandez a quelqu'un de vous aider à le faire.

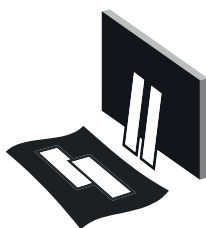

Utilize a embalagem para forrar a área de montagem e separar todas as peças.

Use the packaging to cover the assembly area and separate all parts.

Utilice el embalaje para cubrir la area de montaje y separe las piezas.

Couvrez la zone d'assemblage avec l'emballage pour séparer le pièces.



Limpe com um pano limpo e umedecido em água e sabão neutro. Não utilizar produtos químicos e abrasivos.

Wipe clean using a damp cloth and a mild cleaner. Don't use abrasive and chemical products.

Limpie con un paño limpiohumedecido con agua y jabón neutro. No utilice productos químicos y abrasivos.

Nettoyez avec un chiffon propre imbibé avec d'eau et de savon doux. N'utilisez pas de produits chimiques et abrasifs.



Não colocar objetos em alta temperatura diretamente sobre superfícies de vidro.

Do not place high-temperature objects directly on glass surfaces.

No coloque objetos de alta temperatura directamente sobre superficies de vidro.

Ne placez pas d'objets à haute température directment sur les surfaces en verre.

ACESSÓRIOS HARDWARE HERRAJES ACCESSOIRES

Identifique e separe os acessórios utilizados. Em cada embalagem, uma etiqueta identifica as peças e onde utilizá-las.

Identify and separate the hardware used in the assembly. There's a label on each package identifying the parts and where to use them.

Identifique y separete los accesorios utilizados en el montaje. Observe la etiqueta en cada paquete para saber donde montar.



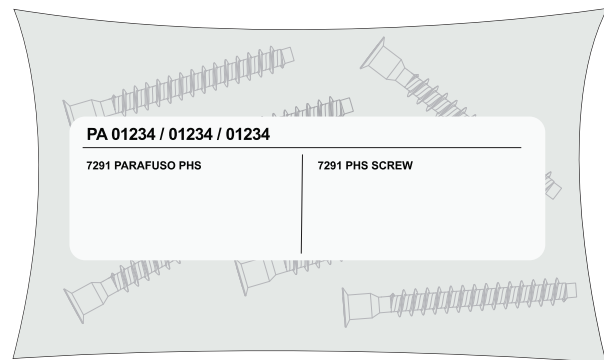





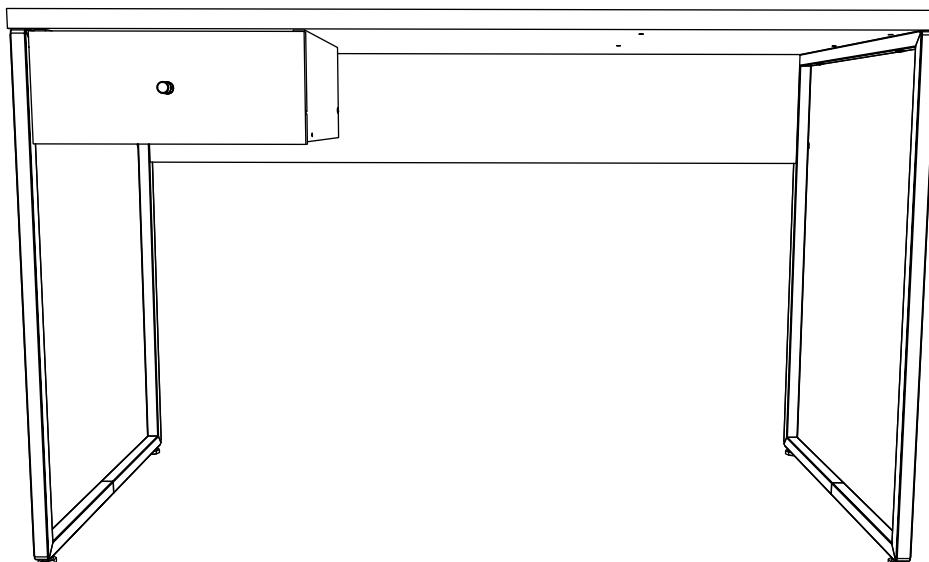

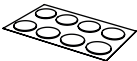
Identifiez et séparez les accessoires à être utilisés. Dans chaque emballage il y a une étiquette pour identifier les pièces et où les utiliser.

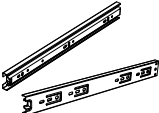

1200 mm

L:1200mm A:750mm P:600mm
W:47.25in H:29.53in D:23.63in
L:1200mm A:750mm P:600mm
L:1200mm H:750mm P:600mm

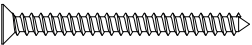
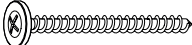
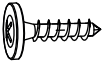

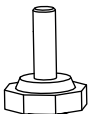
<p>A ADESIVO STICKER ADHESIVO AUTOCOLLANT (04X)</p> 	<p>B COD. 12925 (04X)</p> 	<p>C COD. 1669 (04X)</p> 	<p>D COD. 10063 (04X)</p> 	<p>E COD. 1668 6.0 x 30 (12X)</p> 
<p>F COD. 13579 (01X)</p> 	<p>G COD. 0599 (04X)</p> 	<p>H COD. 1533 4.0 x 14 (08X)</p> 	<p>I COD. 8056 4.5 x 16 (04X)</p> 	<p>J COD. 13135 4.5 x 40 (04X)</p> 
<p>K COD. 0715 4.5 x 50 (06X)</p> 	<p>L COD. 16183 4.5 x 60 (04X)</p> 	<p>M COD. 14135 5.0 x 20 (04X)</p> 	<p>N COD. 3187 M4 x 20 (01X)</p> 	<p>O PUXADOR DOOR HANDLE MANIJA POIGNÉE (01X)</p> 
<p>P COD. 11588 (04X)</p> 				

MONTAGEM NECESSITA 1 PESSOA
 ASSEMBLY REQUIRES 1 PERSON
 EL MONTAJE NECESITA 1 PERSONA
 MONTAGE A 1 PERSONNE

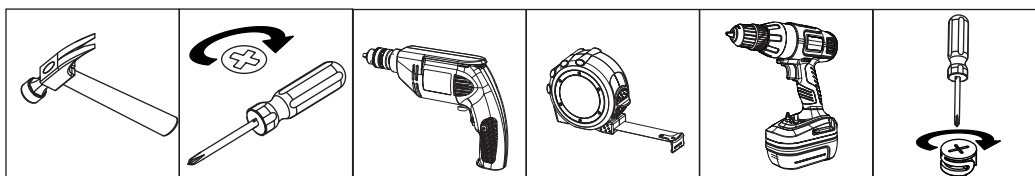

DESCRIÇÃO/ DESCRIPTION/ DESCRIPCIÓN/ DESCRIPTION

COD: 73300

PEÇA PART PIEZA PIÈCE	QUANTIDADE QUANTITY CANTIDAD QUANTITÉ	DESCRIÇÃO	DESCRIPTION	DESCRIPCIÓN	DESCRIPTION	CAIXA BOX CAJA BOÎTE
10	01	TAMPO	TOP PANEL	PANEL SUPERIOR	PLATEAU	01
11	01	CONTRA TAMPO	TABLE BACK PANEL	PANEL TRASERO	PANNEAU ARRIÈRE	01
12	01	LATERAL ESQUERDA	LEFT SIDE	LATERAL IZQUIERDA	CÔTÉ GAUCHE	01
13	01	TRAVA CAIXA GAVETA	DRAWER BOX LOCK	CERRADURA DE CAJÓN	SERRURE DE TIROIR	01
14	01	FUNDO CAIXA GAVETA	DRAWER BOX BOTTOM	FONDO CAJA DEL CAJÓN	FOND DE LA BOÎTE À TIROIR	01
15	01	LATERAL DIREITA	RIGHT SIDE	LATERAL DERECHA	CÔTÉ DROITE	01
66	01	FRENTE GAVETA	DRAWER FRONT	FRENTE DEL CAJÓN	FAÇADE DE TIROIR	01
67	01	LATERAL GAVETA ESQ.	LEFT DRAWER SIDE	CAJÓN LATERAL IZQ.	CÔTÉ DE TIROIR	01
68	01	LATERAL GAVETA DIR.	RIGHT DRAWER SIDE	CAJÓN LATERAL DER.	CÔTÉ DE TIROIR	01
69	01	CONTRA FUNDO	DRAWER BACK PANEL	CAJÓN INFERIOR	DERRIÈRE	01
70	01	FUNDO GAVETA	DRAWER BOTTOM	FONDO DEL CAJÓN	FOND DE TIROIR	01
139	02	BASE LATERAL	SIDE BASE	BASE LATERAL	BASE LATÉRALE	01

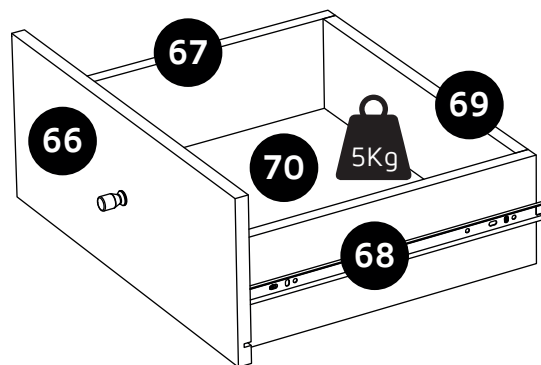
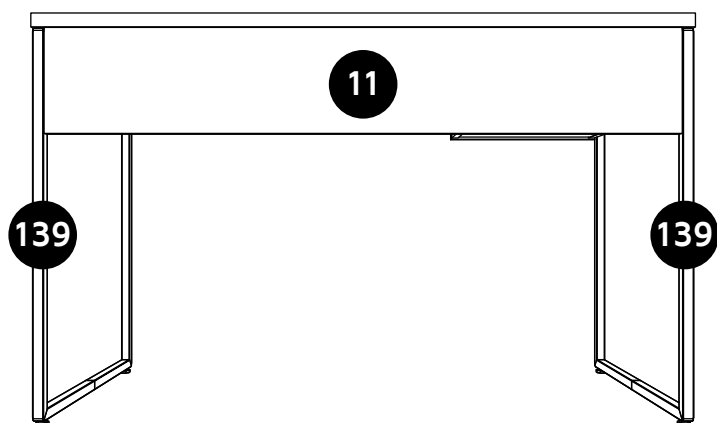
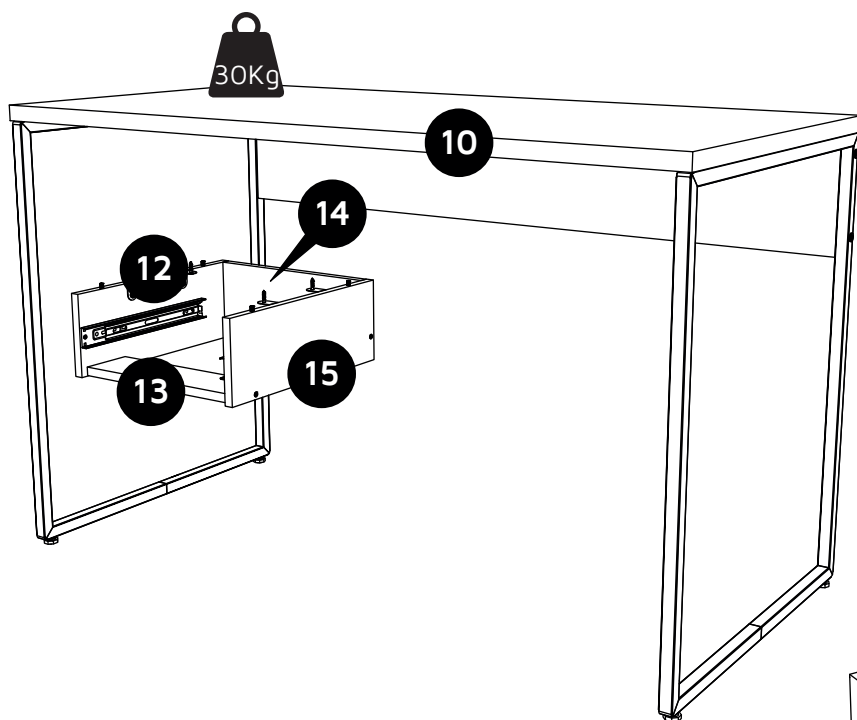

30Kg = 66Lb
5Kg = 11Lb

01

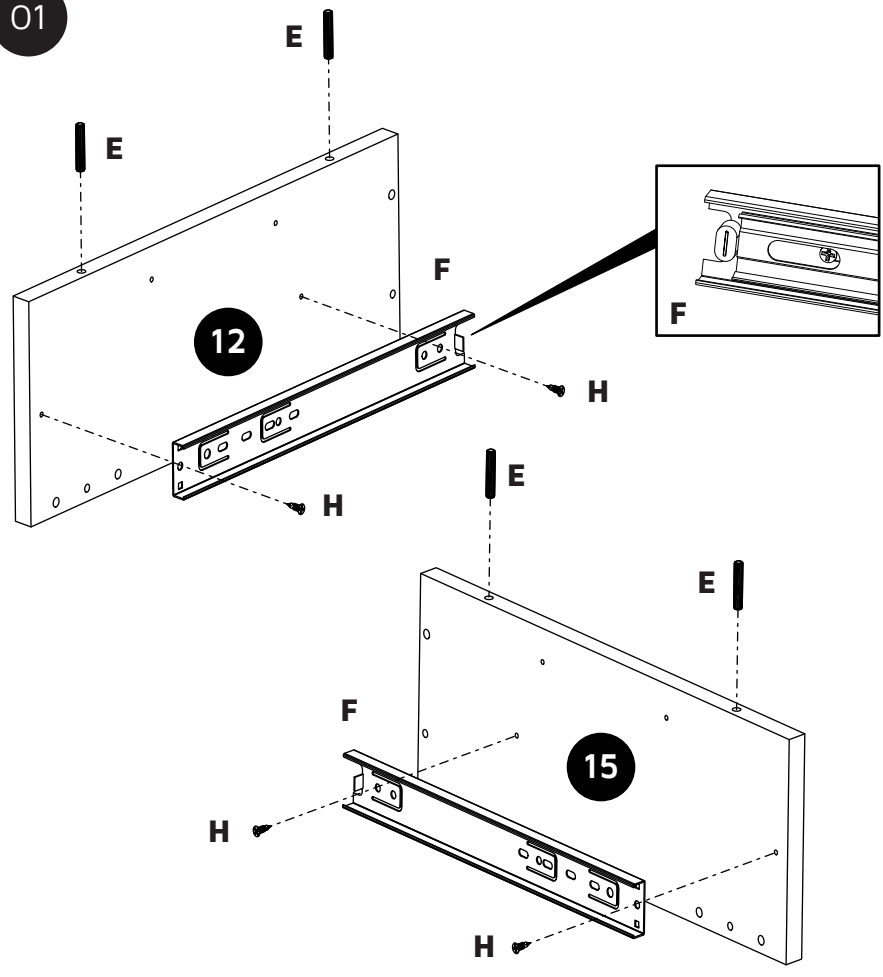

E COD. 1668	F COD. 13579	H COD. 1533

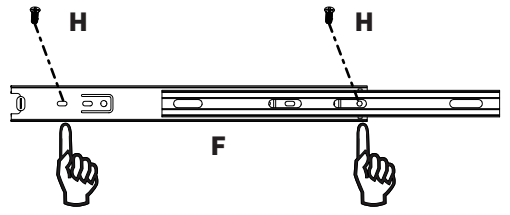

PASSO 01
Parafusar 2x(H) e a correçã 1x(F)
na peça 12/15.

STEP 01
Screw 2x(H) and the slides 1x(F)
on the part 12/15.

PASO 01
Atornillar 2x(H) y las correderas 1x(F)
en la pieza 12/15.

ÉTAPE 01
Vissez 2x(H) et les curseurs 1x(F)
dans la pièce 12/15.

02

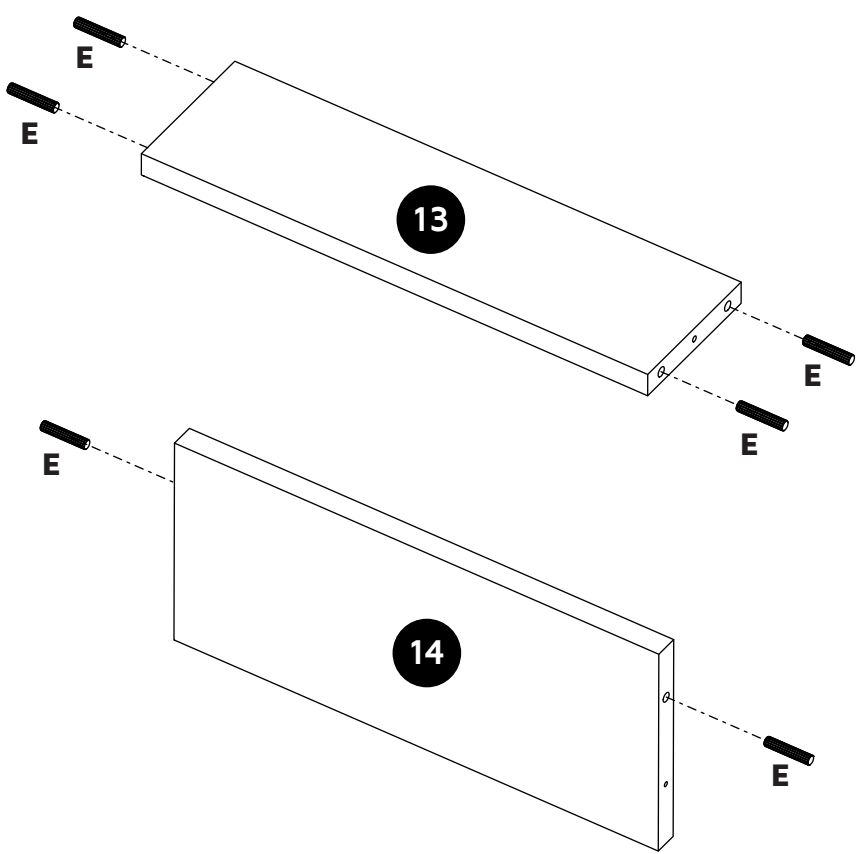

PASSO 02
Encaixar cavilhas 4x(H) na peça 13
e 2x(H) na peça 14.

STEP 02
Insert dowels 4x(H) on the part 13
and 2x(H) on the part 14.

PASO 02
Clavijas de ajuste 4x(H) en la pieza 13
y 2x(H) en la pieza 14.

ÉTAPE 02
Insérez les chevilles 4x(H) dans la pièce 13
et 2x(H) dans la pièce 14.

03



PASSO 03
Encaixar peça **13** e **14** e parafusar 2x(**K**).

PASO 03
Montar la peça **13** y **14** y atornillar 2x(**K**).

STEP 03
Attach part **13** and **14** and screw 2x(**K**).

ÉTAPE 03
Insérez le pièce **13** et **14** et vissez 2x(**K**).

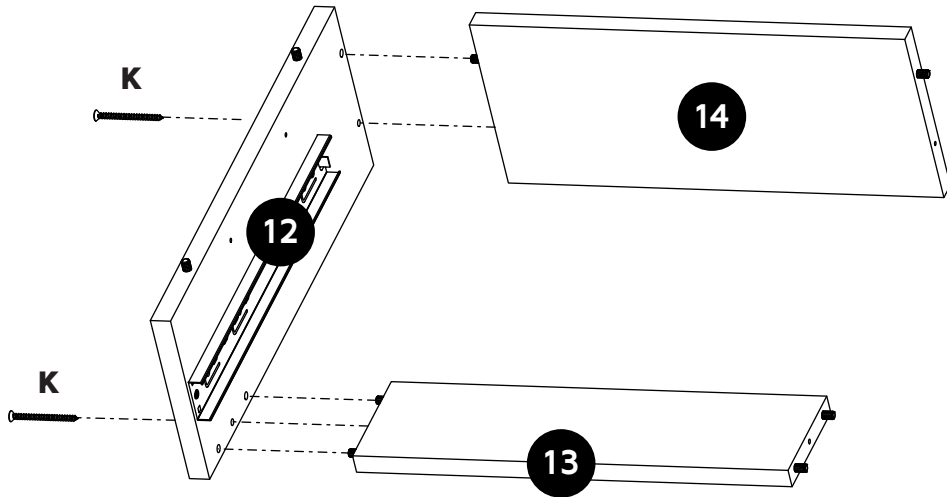

04





PASSO 04
Encaixar peça **15** e parafusar 2x(**K**).

PASO 04
Montar la peça **15** y atornillar 2x(**K**).

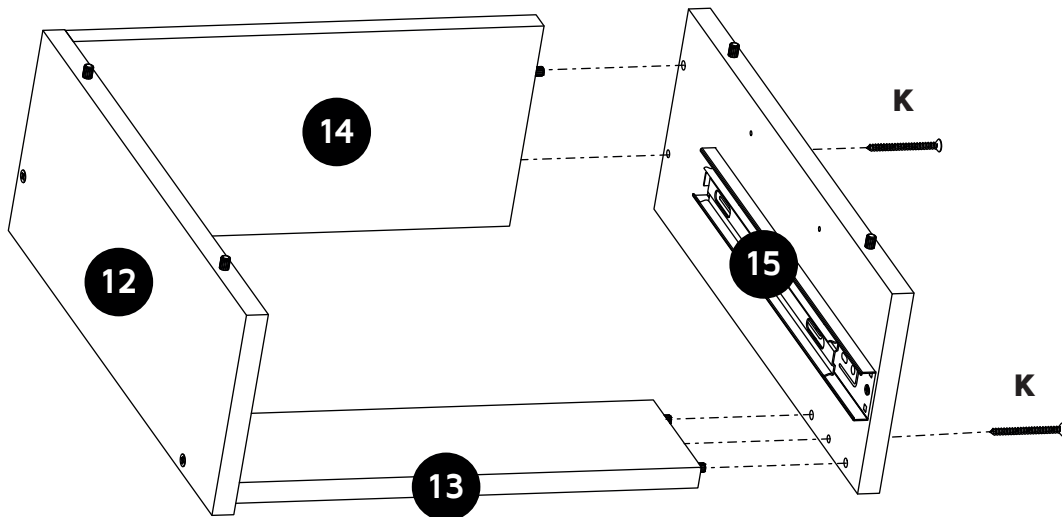
STEP 04
Attach part **15** and screw 2x(**K**).

ÉTAPE 04
Insérez le pièce **15** et vissez 2x(**K**).



E	F	H	K
COD. 1668	COD. 13579	COD. 1533	COD. 0715
			

PASSO 05
Parafusar 2x(H) as corredeiras 1x(F) nas laterais gaveta esquerda e direita **67/68**.

STEP 05
Screw 2x(H) the slides 1x(F) on the left and right drawer side **67/68**.

PASO 05
Atornillar 2x(H) las correderas 1x(F) en los cajóns laterales izquierda y derecha **67/68**.

ÉTAPE 05
Vissez 2x(H) les curseurs 1x(F) sur les tiroir latéral gauche et droit **67/68**.

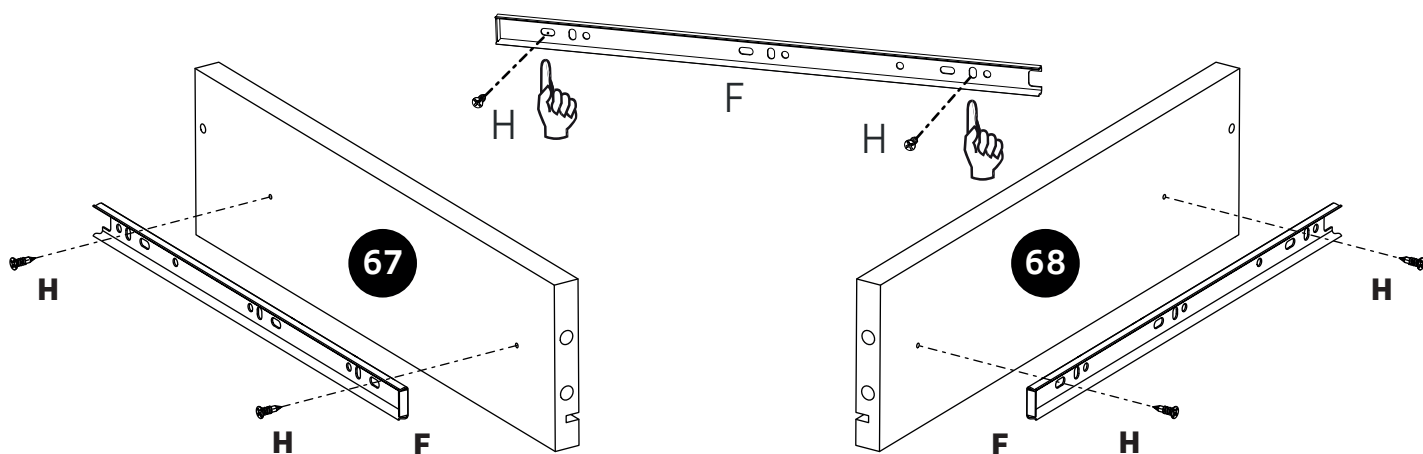

PASSO 06
Encaixar cavilhas 2x(E) no contra fundo **69**.
Encaixar laterais gaveta esquerda e direita **67/68** no contra fundo **69** e parafusar 2x(K).

STEP 06
Insert dowels 2x(E) on drawer back panel **69**.
Attach left and right drawer side **67/68** on the drawer back panel **69** and screw 2x(K).

PASO 06
Clavijas de ajuste 2x(E) en cajón inferior **69**.
Montar cajóns laterales izquierda y derecha **67/68** en lo cajón inferior **69** y atornillar 2x(K).

ÉTAPE 06
Insérez les chevilles 2x(E) derrière **69**.
Insérez tiroir latéral gauche et droit **67/68** dans derrière **69** et vissez 2x(K).

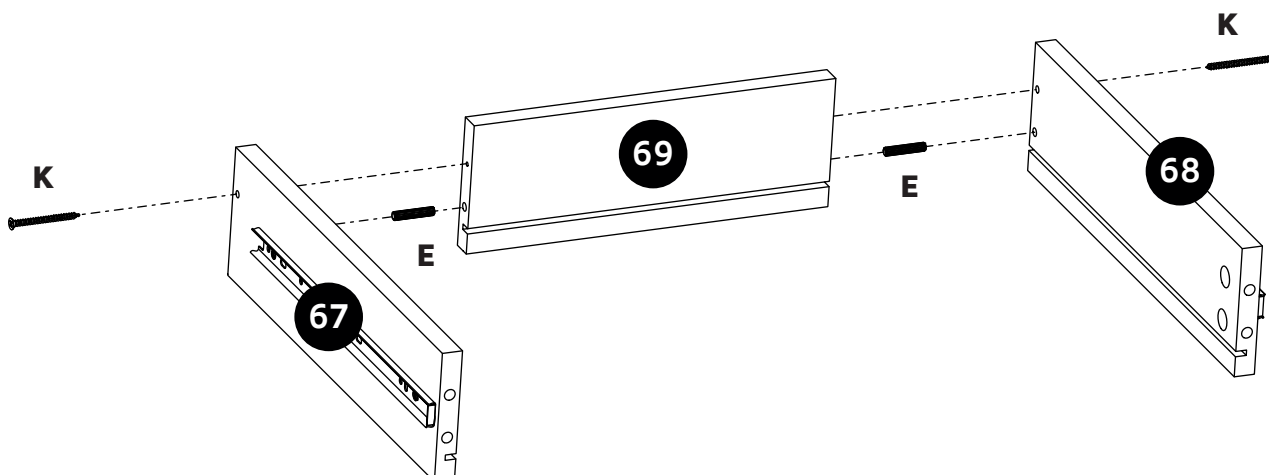

07

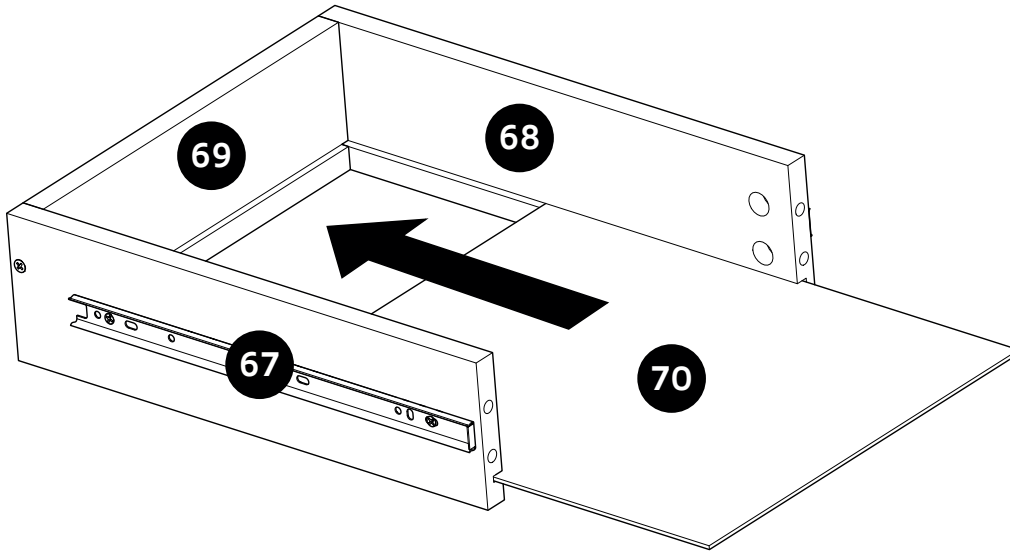
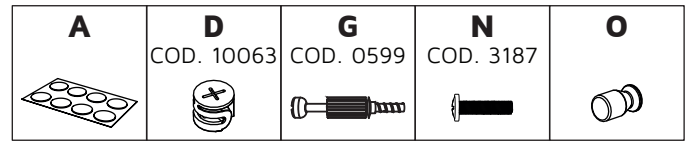

PASSO 07
Encaixar fundo gaveta **70**.

STEP 07
Attach drawer bottom **70**.

PASO 07
Montar fondo del cajon **70**.

ÉTAPE 07
Insérez fond de tiroir **70**.

08

PASSO 08
Encaixar frente gaveta **66**, parafusar castanhas 4x(**D**) e colar 4x(**A**).
Parafusar 1x(**N**) o puxador 1x(**O**).

STEP 08
Attach drawer front **66**, screw nuts 4x(**D**) and place 4x(**A**).
Screw 1x(**N**) the door handle 1x(**O**).

PASO 08
Montar frente del cajón **66**, atornillar las tuercas 4x(**D**) y pegar 4x(**A**).
Atornillar 1x(**N**) el manija 1x(**O**).

ÉTAPE 08
Insérez façade de tiroir **66**, vissez le brunette 4x(**D**) et collez 4x(**A**).
Vissez 1x(**N**) et poignée 1x(**O**).

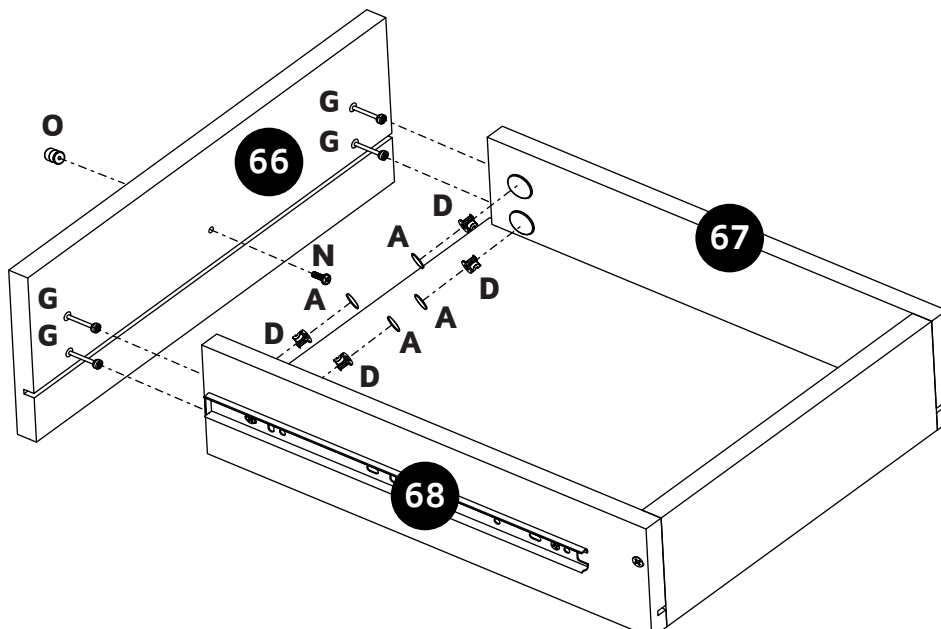

09

PASSO 09
Encaixar peça **11** e na base **139**
e parafusar 02x(L).

STEP 09
Attach part **11** on base **139**
and screw 02x(L).

PASO 09
Montar la pieza **11** en la base **139**
y atornillar 02x(L).

ÉTAPE 09
Insérez la pièce **11** dans la base **139**
et vissez 02x(L).

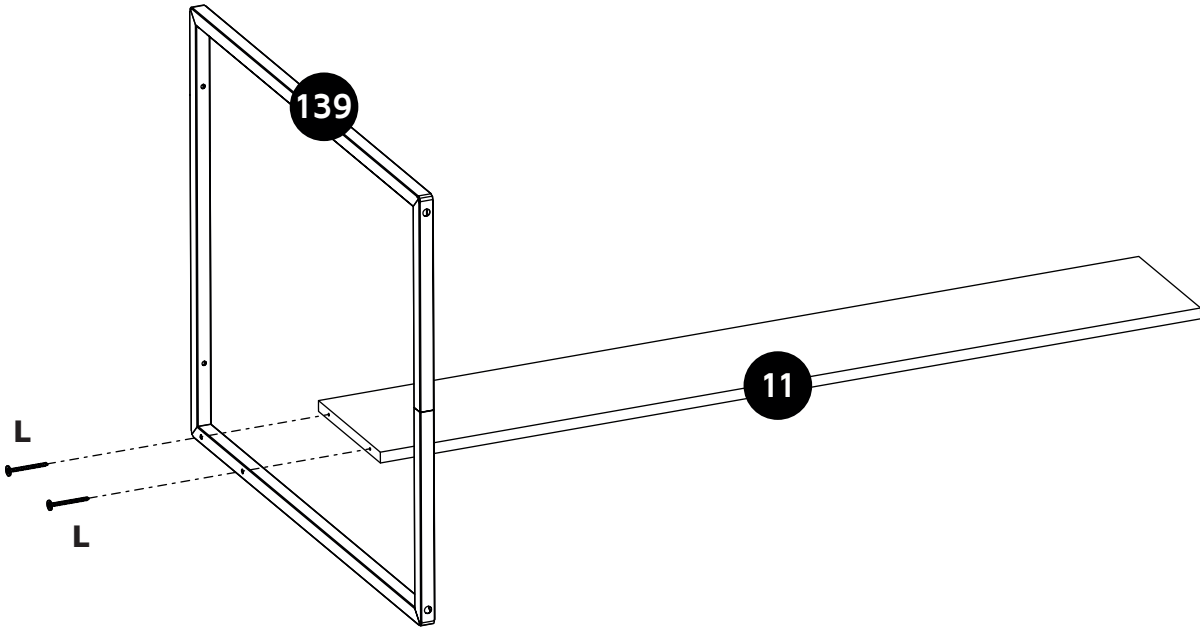
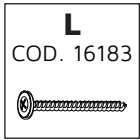

10

PASSO 10
Encaixar peça **11** e na base **139**
e parafusar 02x(L).



STEP 10
Attach part **11** on base **139**
and screw 02x(L).

PASO 10
Montar la pieza **11** en la base **139**
y atornillar 02x(L).

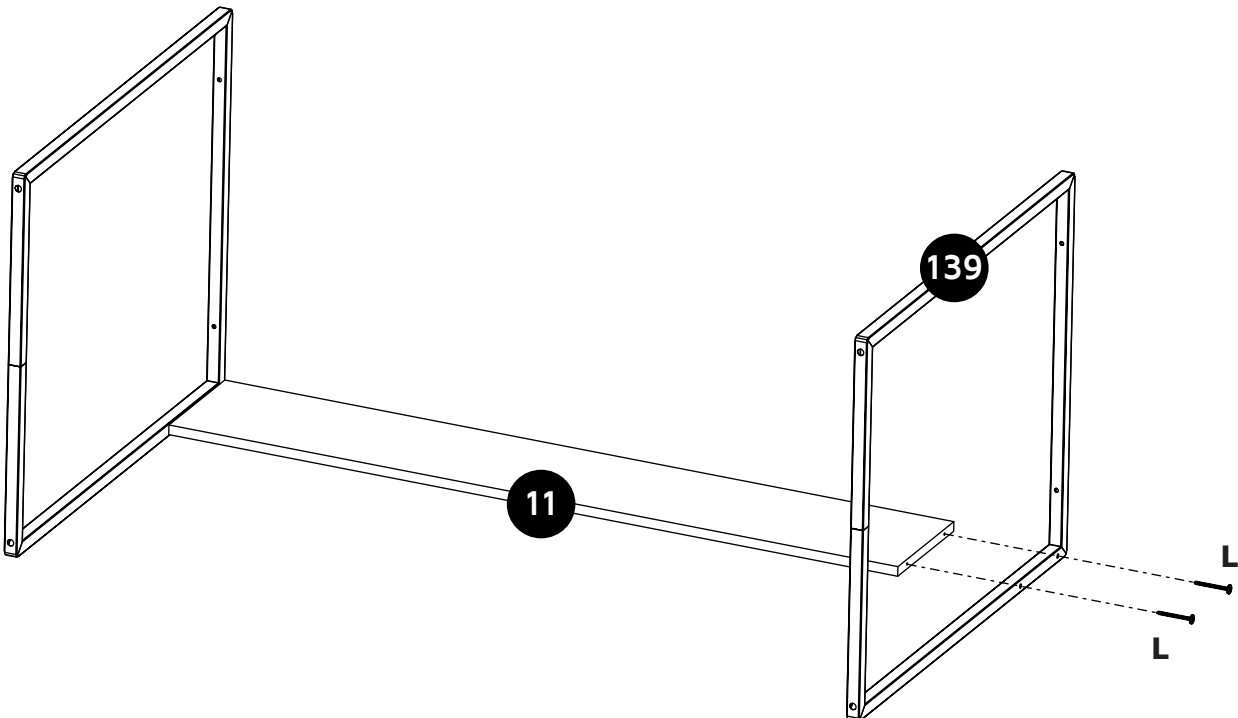
ÉTAPE 10
Insérez la pièce **11** dans la base **139**
et vissez 02x(L).



11

B COD. 12925	J COD. 13135	P COD. 11588
		

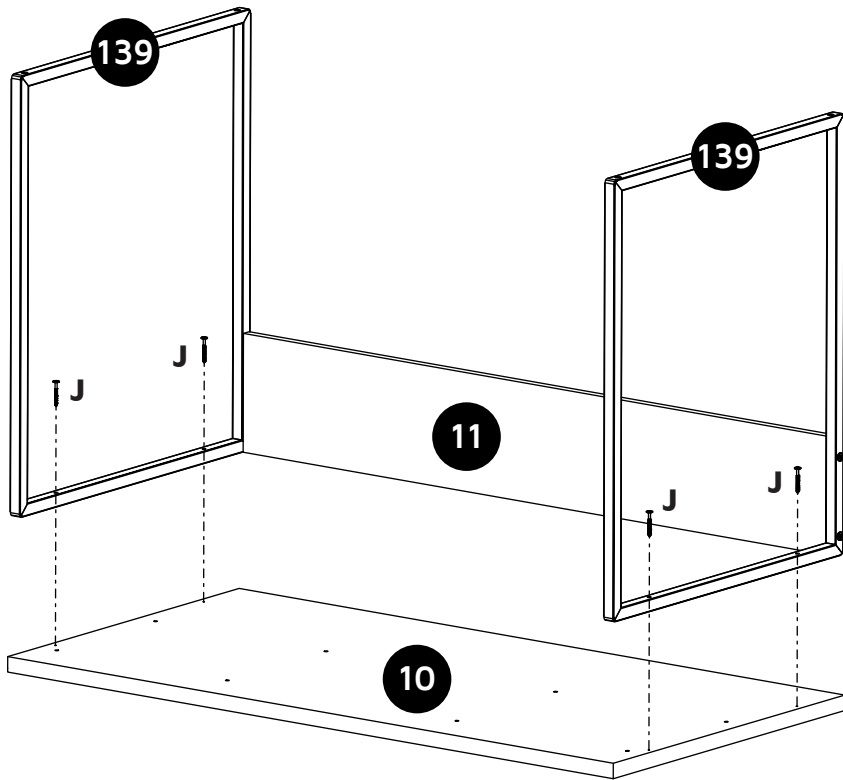

PASSO 11
Posicionar a base **139** no tampo **10** e parafusar 04x(**J**).

STEP 11
Position the base **139** on the top panel **10** and screw 04x(**J**).

PASO 11
Colocar la basea **139** en el panel superior **10** y atornillar 04x(**J**).

ÉTAPE 11
Positionner la base **139** au plateau **10** et visser 04x(**J**).

12

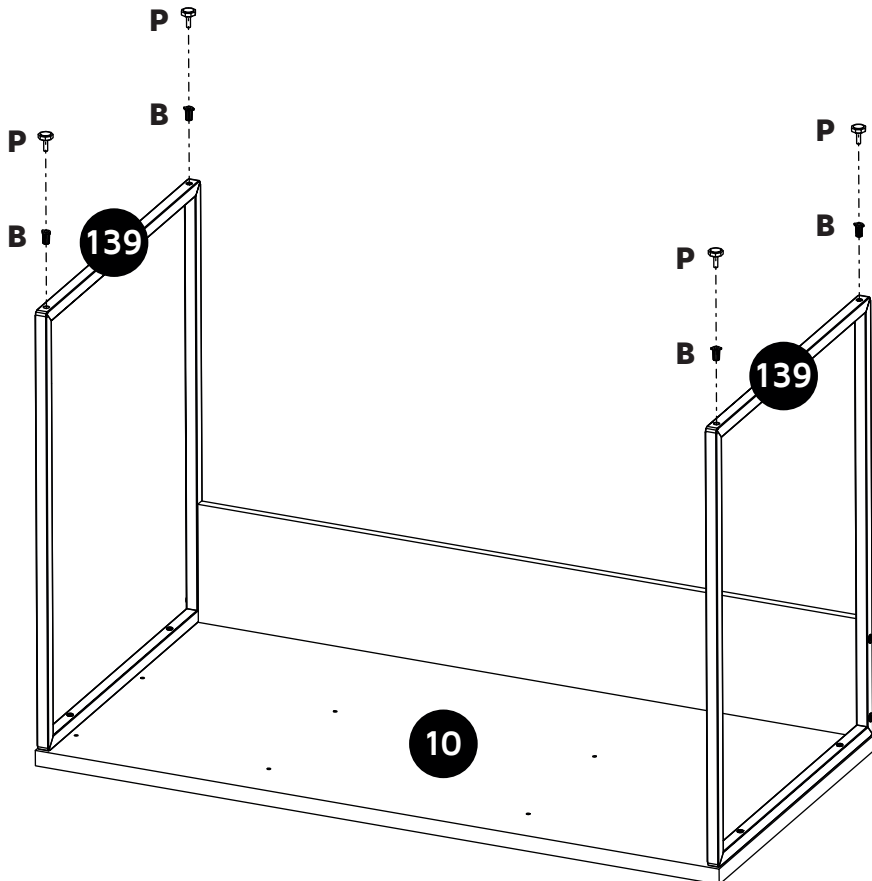

PASSO 12
Encaixar 4x(**B**) e sapata 4x(**P**) na base **139**.

STEP 12
Attach 4x(**B**) and plastic topper 4x(**P**) in base **139**.

PASO 12
Enganchar 4x(**B**) y almohadilla de plastico 4x(**P**) en la base **139**.

ÉTAPE 12
Insérez 4x(**B**) et le touchon plastique 4x(**P**) dans la base **139**.

13

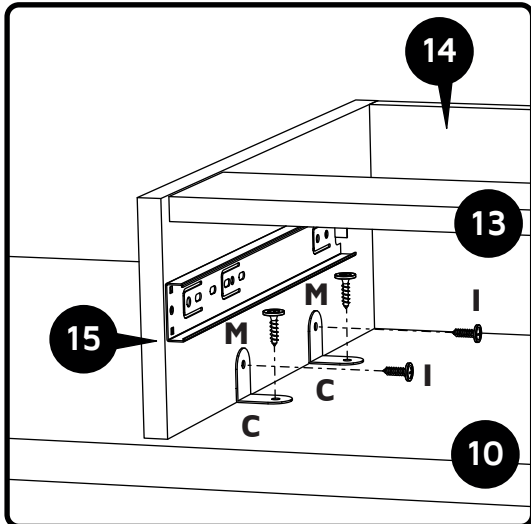

PASSO 13

Posicionar a peça **12/14/15** no tampo **10**, encaixar 04x(**C**) e parafusar 04x(**I**)/04x(**M**)

STEP 13

Position the part **12/14/15** on the top panel **10**, attach 04x(**C**) and screw 04x(**I**)/04x(**M**).

PASO 13

Colocar la pieza **12/14/15** en el panel superior **10**, montar 04x(**C**) y atornillar 04x(**I**)/04x(**M**).

ÉTAPE 13

Positionner la pièce **12/14/15** au plateau **10**, insérez 04x(**C**) et visser 04x(**I**)/04x(**M**).

C	I	M
COD. 7313	COD. 8056	COD. 14135

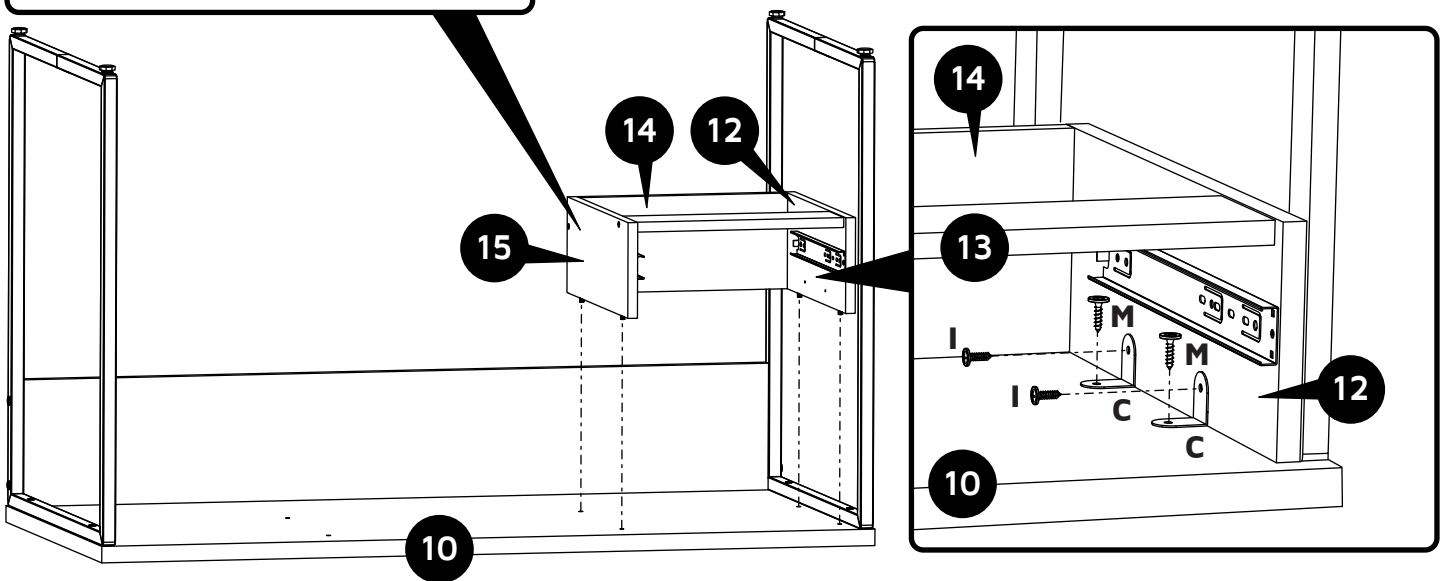

14

