

MANUAL DE MONTAGEM

ASSEMBLY INSTRUCTIONS

INSTRUCCIONES DE MONTAJE

NOTICE DE MONTAGE

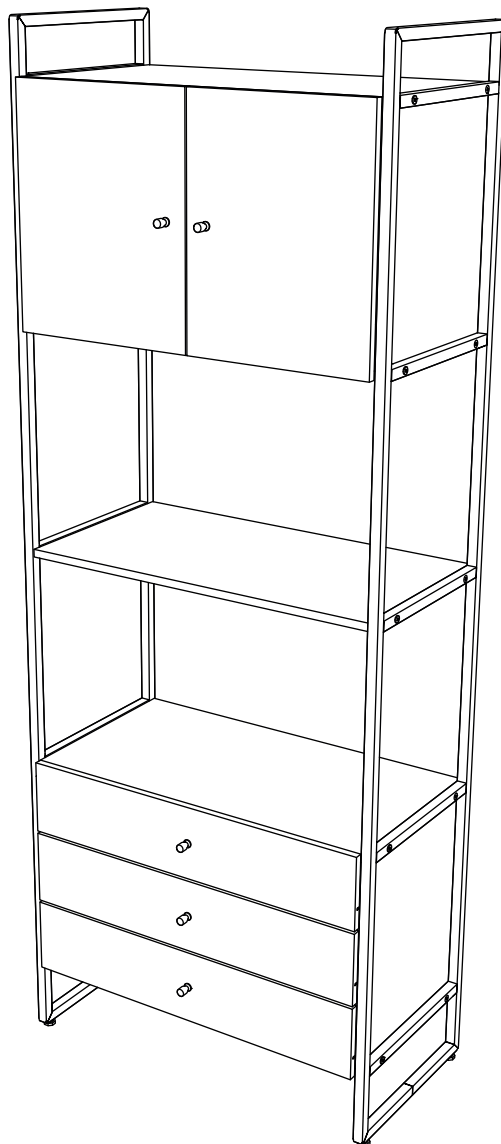

COD: 402900

REV. 00 - 02/10/23

OBSERVAÇÕES IMPORTANTES IMPORTANT REMARKS OBSERVACIONES IMPORTANTES REMARQUES IMPORTANTES



Nunca escale ou se apoie sobre o móvel. Você pode sofrer graves acidentes.

Never climb or lean on the furniture. You may suffer serious accidents.

Nunca escale o apoie sobre el mobiliario. Usted puede sufrir graves accidentes.

Ne montez jamais sur le meuble. Vous pourriez subir un grave accident.

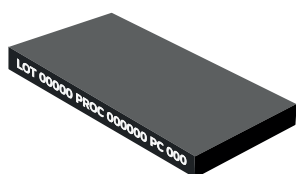

Observe os números impressos nas bordas para identificar as peças.

Identify the parts by observing the number printed on their edges.

Identifique las piezas observando el numero impreso en sus bordes.

Notez les numéros imprimés sur les bords pour identifier les pièces.



Movimente o móvel com cuidado, sem arrastar. Peça ajuda a outra pessoa para fazê-lo.

Move the piece carefully, don't drag it. Ask for someone else's help to do so.

Mover la unidad con cuidado, sin arrastar. Pedir ayuda da otra persona para moverlo.

Déplacez les meubles avec précaution sans le faire glisser. Demandez a quelqu'un de vous aider à le faire.

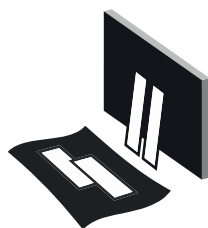

Utilize a embalagem para forrar a área de montagem e separar todas as peças.

Use the packaging to cover the assembly area and separate all parts.

Utilice el embalaje para cubrir la area de montaje y separe las piezas.

Couvrez la zone d'assemblage avec l'emballage pour séparer le pièces.



Limpe com um pano limpo e umedecido em água e sabão neutro. Não utilizar produtos químicos e abrasivos.

Wipe clean using a damp cloth and a mild cleaner. Don't use abrasive and chemical products.

Limpie con un paño limpiohumedecido con agua y jabón neutro. No utilice productos químicos y abrasivos.

Nettoyez avec un chiffon propre imbibé avec d'eau et de savon doux. N'utilisez pas de produits chimiques et abrasifs.



Não colocar objetos em alta temperatura diretamente sobre superfícies de vidro.

Do not place high-temperature objects directly on glass surfaces.

No coloque objetos de alta temperatura directamente sobre superficies de vidro.

Ne placez pas d'objets à haute température directment sur les surfaces en verre.

ACESSÓRIOS HARDWARE HERRAJES ACCESSOIRES

Identifique e separe os acessórios utilizados. Em cada embalagem, uma etiqueta identifica as peças e onde utilizá-las.

Identify and separate the hardware used in the assembly. There's a label on each package identifying the parts and where to use them.

Identifique y separete los accesorios utilizados en el montaje. Observe la etiqueta en cada paquete para saber donde montar.



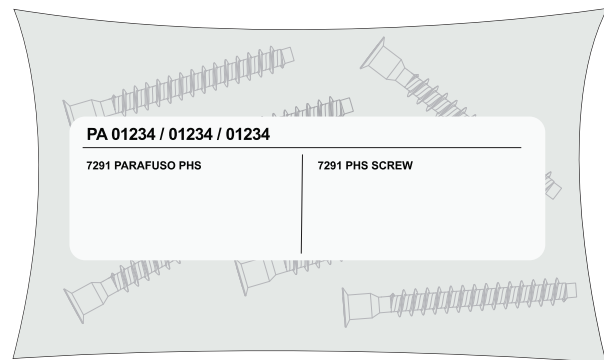





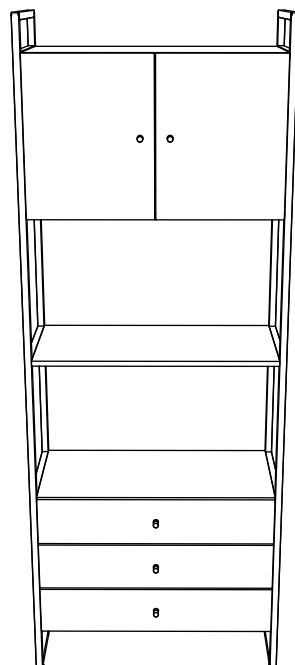

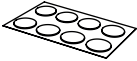

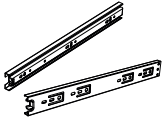

Identifiez et séparez les accessoires à être utilisés. Dans chaque emballage il y a une étiquette pour identifier les pièces et où les utiliser.



755 mm

L:755mm A:1983mm P:386mm
W:29.73in H:78.07in D:15.20in
L:755mm A:1983mm P:386mm
L:755mm H:1983mm P:386mm

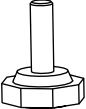

<p>A ADESIVO STICKER ADHESIVO AUTOCOLLANT</p> <p>(16X)</p> 	<p>B COD. 12925 (04X)</p> 	<p>C COD. 10063 (20X)</p> 	<p>D COD. 1668 6.0 x 30 (34X)</p> 	<p>E COD. 13579 (03X)</p> 
<p>F COD. 2511 (04X)</p> 	<p>G COD. 0599 (20X)</p> 	<p>H COD. 1533 4.0 x 14 (24X)</p> 	<p>I COD. 7519 4.5 x 16 (24X)</p> 	<p>J COD. 0715 4.5 x 50 (06X)</p> 
<p>K COD. 16183 4.5 X 60 (20X)</p> 	<p>L COD. 3187 M4 X 20 (05X)</p> 	<p>M PUXADOR DOOR HANDLE MANIJA POIGNÉE (05X)</p> 	<p>N COD. 0357 8.0 x 8.0 (28X)</p> 	<p>O COD. 11588 (04X)</p> 

MONTAGEM NECESSITA 1 PESSOA
 ASSEMBLY REQUIRES 1 PERSON
 EL MONTAJE NECESITA 1 PERSONA
 MONTAGE A 1 PERSONNE

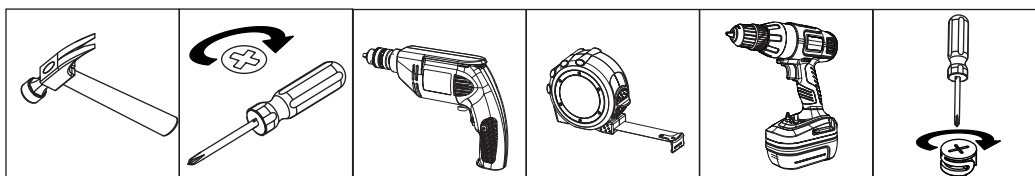



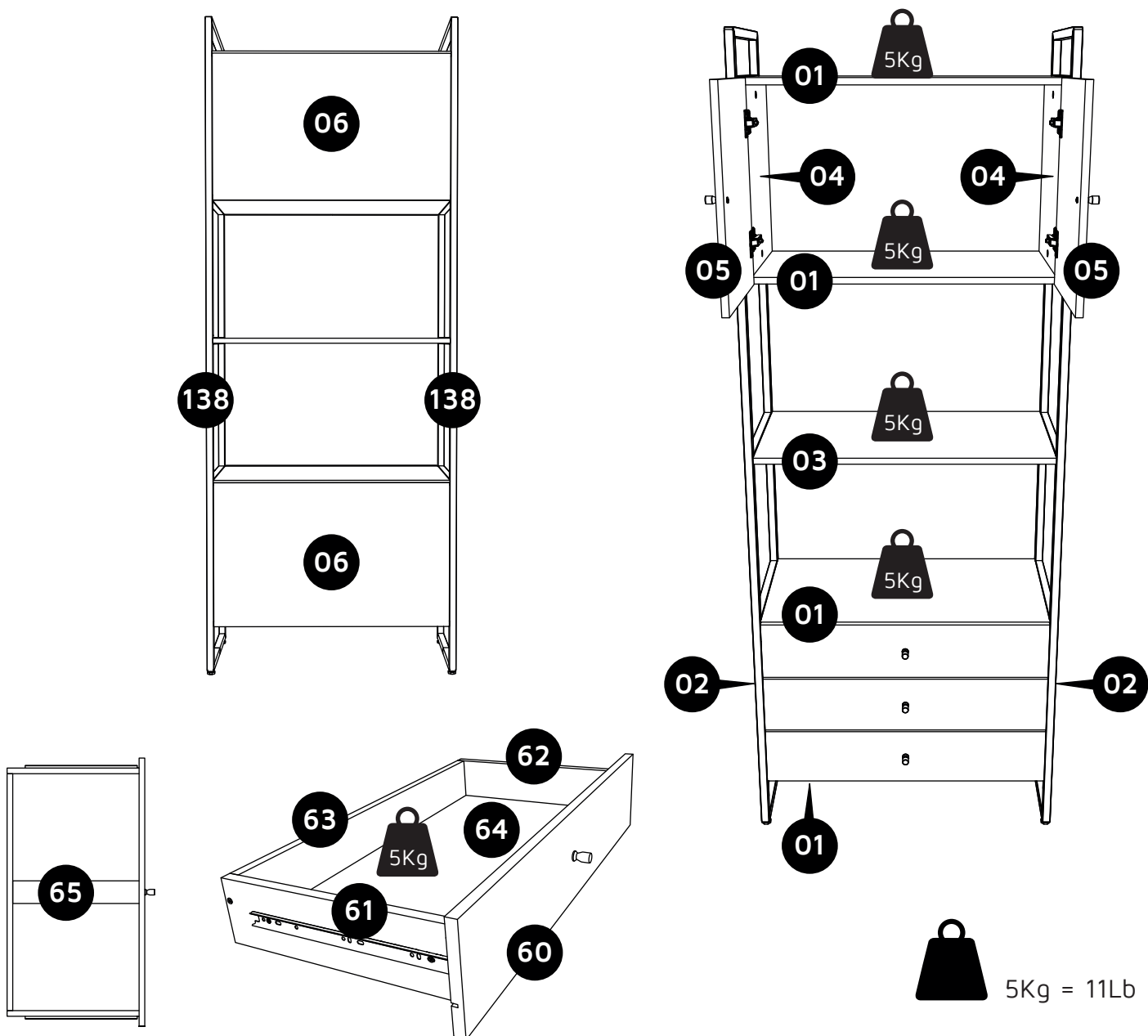

DESCRIÇÃO/ DESCRIPTION/ DESCRIPCIÓN/ DESCRIPTION

COD: 402900

PEÇA PART PIEZA PIÈCE	QUANTIDADE QUANTITY CANTIDAD QUANTITÉ	DESCRIÇÃO	DESCRIPTION	DESCRIPCIÓN	DESCRIPTION	CAIXA BOX CAJA BOÎTE
01	04	BASE / TAMPO	BASE / TOP PANEL	BASE / CUBIERTA	BASE / PLATEAU	01
02	02	LATERAL GAVETEIRO	SIDE	LATERAL	CÔTÉ	01
03	01	PRATELEIRA	TOP SHELF	ESTANTE	ÉTAGÈRE	01
04	02	LATERAL	SIDE	LATERAL	CÔTÉ	01
05	02	PORTA	DOOR	PUERTA	PORTE	01
06	02	FUNDO	BACKPLATE	FONDO	FOND	01
60	03	FRENTE GAVETA	DRAWER FRONT	FRENTE DEL CAJÓN	FAÇADE DE TIROIR	01
61	03	LATERAL GAVETA ESQ.	LEFT DRAWER SIDE	CAJÓN LATERAL IZQ.	CÔTÉ DE TIROIR	01
62	03	LATERAL GAVETA DIR.	RIGHT DRAWER SIDE	CAJÓN LATERAL DER.	CÔTÉ DE TIROIR	01
63	03	CONTRA FUNDO	DRAWER BACK PANEL	CAJÓN INFERIOR	DERRIÈRE	01
64	03	FUNDO GAVETA	DRAWER BOTTOM	FONDO DEL CAJÓN	FOND DE TIROIR	01
65	03	TRAVESSA GAVETA	DRAWER CROSSPIECE	TRAVESAÑO CAJÓN	BARREAU	01
138	02	BASE LATERAL	SIDE BASE	BASE LATERAL	BASE LATÉRALE	01



01

D COD. 1668 	E COD. 13579 	G COD. 0599 	H COD. 1533 
---	---	--	--

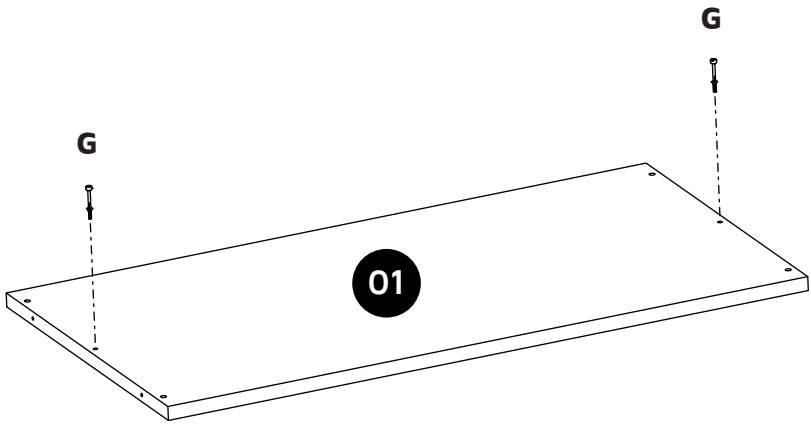

PASSO 01
Parafusar minifix 2x(**G**) na base/tampo **01**.

STEP 01
Screw minifix 2x(**G**) on base/top panel **01**.

PASO 01
Atornillar el minifix 2x(**G**) en la base/cubierta **01**.

ÉTAPE 01
Vissez le minifix 2x(**G**) dans la base/plateau **01**.

(4x)

02

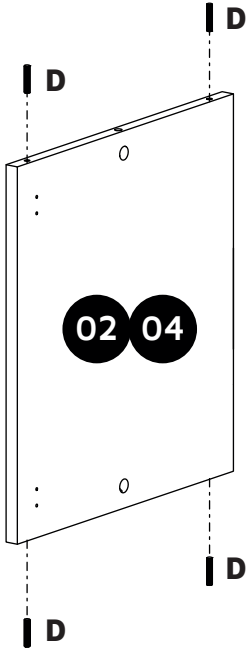

PASSO 02
Encaixar cavilhas 4x(**D**) na lateral **02/04**.

STEP 02
Insert dowels 4x(**D**) on the side **02/04**.

PASO 02
Clavijas de ajuste 4x(**D**) en el lateral **02/04**.

ÉTAPE 02
Insérez les chevilles 4x(**D**) et côté **02/04**.

(4x)

03

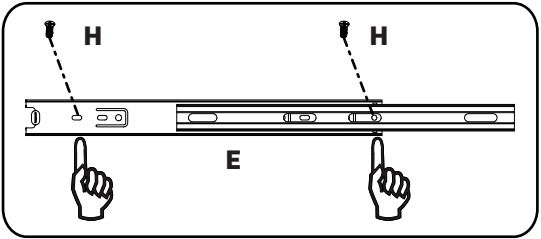
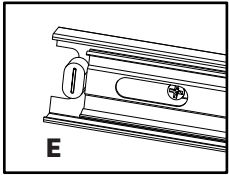
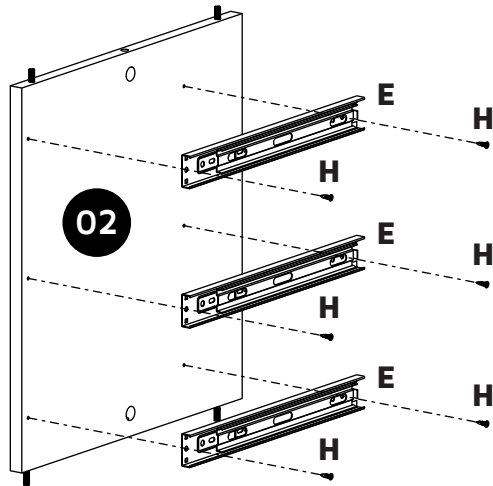

PASSO 03
Parafusar 6x(**H**) as correijas 3x(**E**) na lateral **02**.

STEP 03
Screw 6x(**H**) the slides 3x(**E**) on the side **02**.

PASO 03
Atornillar 6x(**H**) las correderas 3x(**E**) en la lateral **02**.

ÉTAPE 03
Vissez 6x(**H**) les curseurs 3x(**E**) sur les côté **02**.

(2x)

04

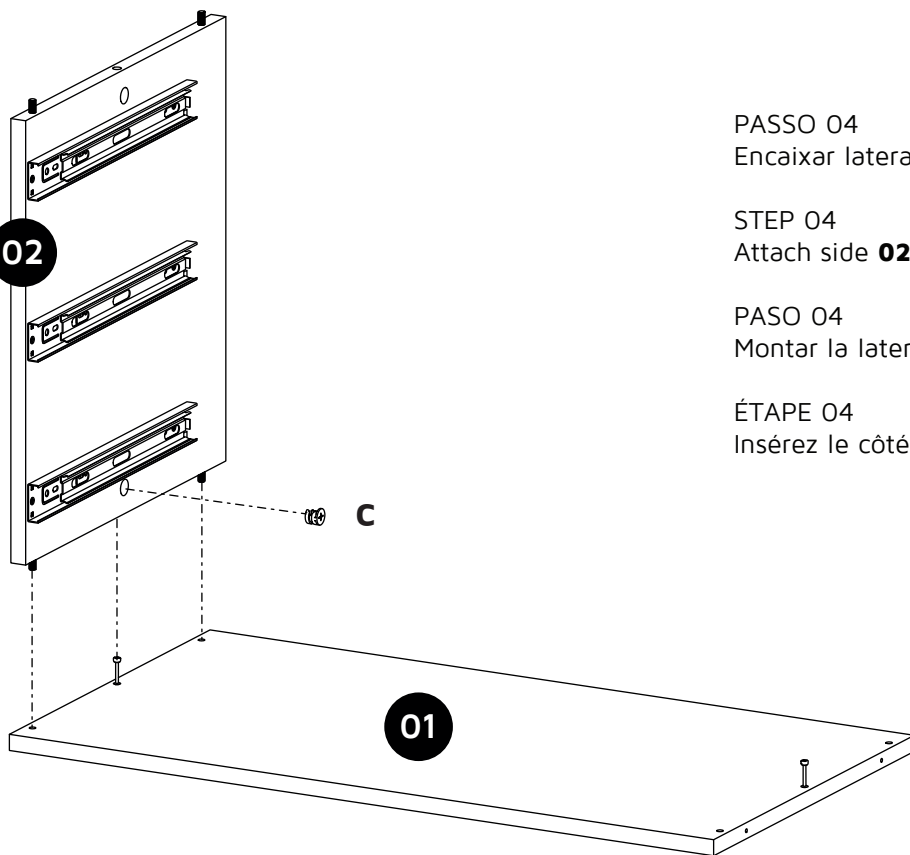
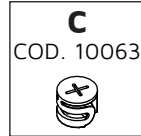

PASSO 04
Encaixar lateral **02** e parafusar castanhas 1x(**C**).

STEP 04
Attach side **02** and screw nuts 1x(**C**).

PASO 04
Montar la lateral **02** y atornillar las tuercas 1x(**C**).

ÉTAPE 04
Insérez le côté **02** et vissez le brunette 1x(**C**).

05

PASSO 05
Encaixar lateral **02** e parafusar castanhas 1x(**C**).



STEP 05
Attach side **02** and screw nuts 1x(**C**).

PASO 05
Montar la lateral **02** y atornillar las tuercas 1x(**C**).

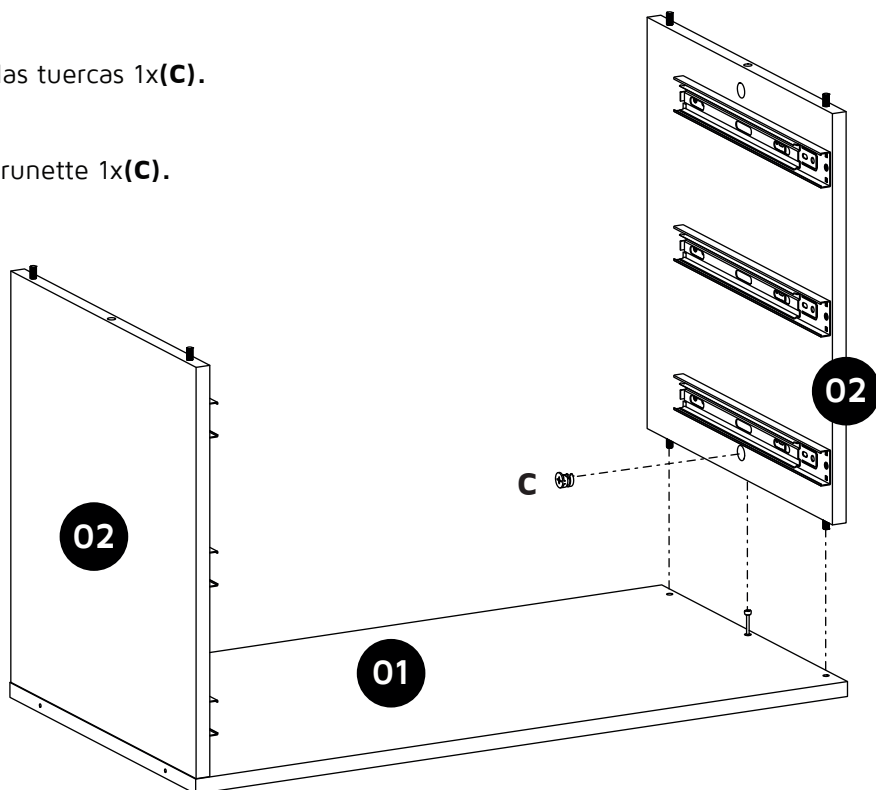
ÉTAPE 05
Insérez le côté **02** et vissez le brunette 1x(**C**).



06

C COD. 10063 	N COD. 0357 
---	--

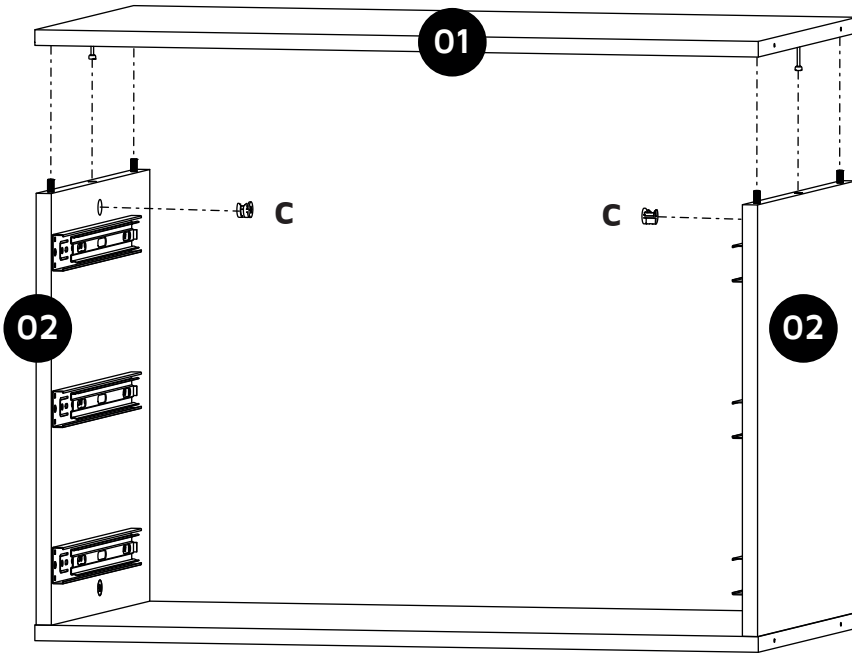

PASSO 06

Encaixar base/tampo **01** e parafusar castanhas 2x(**C**).

STEP 06

Attach base/top panel **01** and screw nuts 2x(**C**).

PASO 06

Montar a base/cubierta **01** y atornillar las tuercas 2x(**C**).

ÉTAPE 06

Insérez la base/plateau **01** et vissez le brunette 2x(**C**).

07

PASSO 07

Encaixar fundo **06** e pregar 14x(**N**).

STEP 07

Attach backplate **06** and nailing 14x(**N**).

PASO 07

Enganchar el fondo **06** y clavar 14x(**N**).

ÉTAPE 07

Insérez le fond **06** et clouer 14x(**N**).

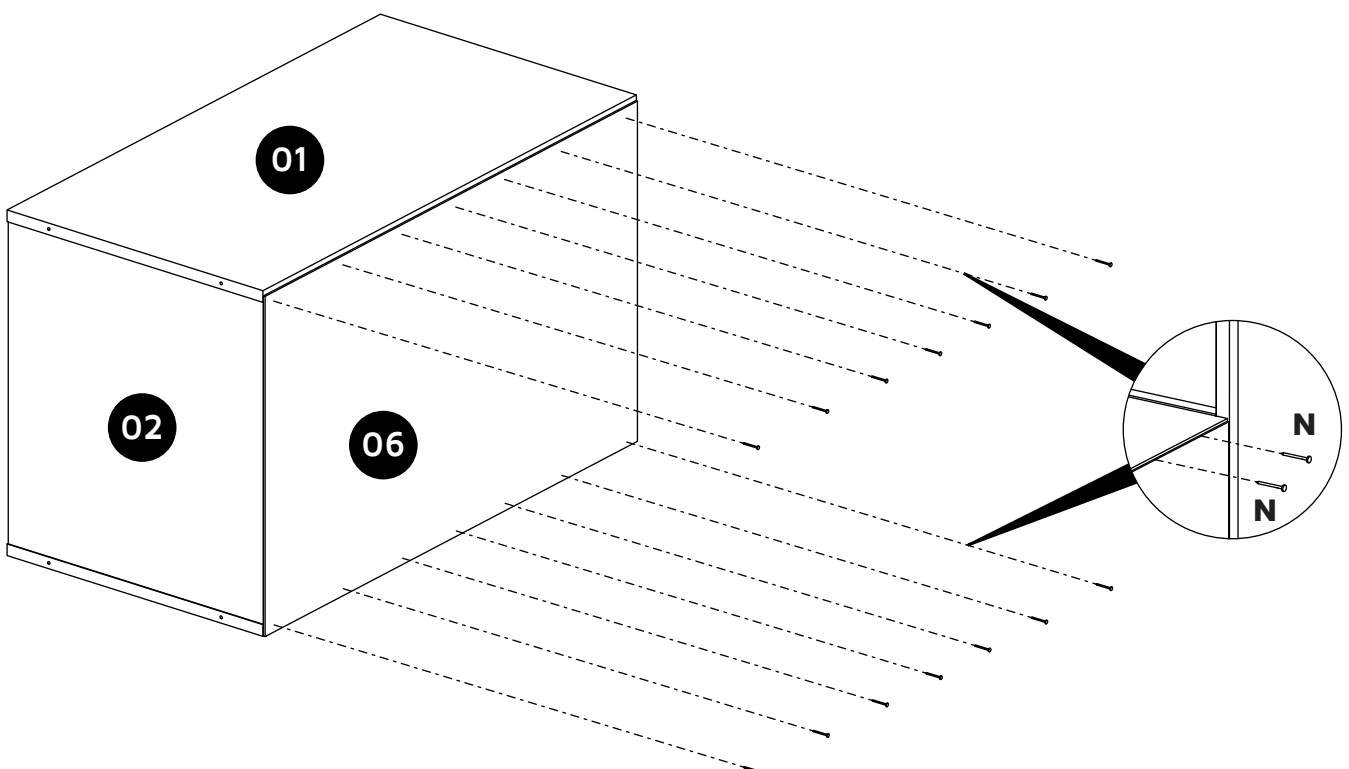

08

08

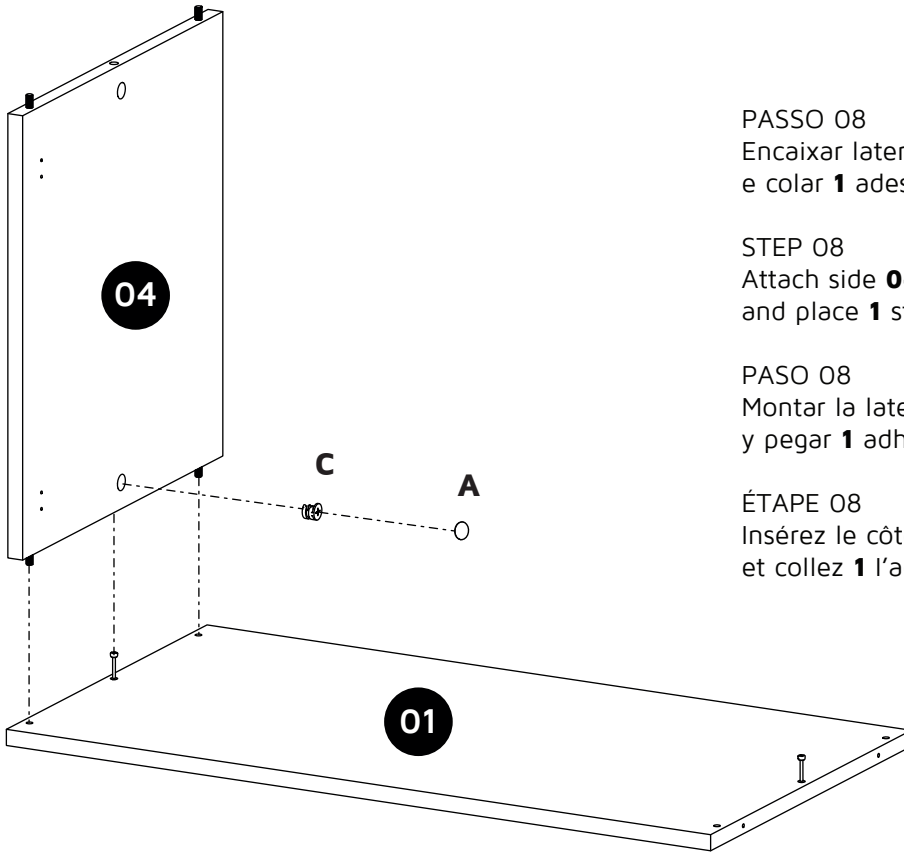
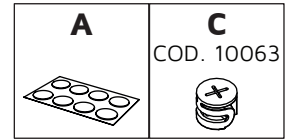

PASSO 08

Encaixar lateral **04** e parafusar castanhas 1x(**C**) e colar **1** adesivos.

STEP 08

Attach side **04** and screw nuts 1x(**C**) and place **1** stickers.

PASO 08

Montar la lateral **04** y atornillar las tuercas 1x(**C**) y pegar **1** adhesivos.

ÉTAPE 08

Insérez le côté **04** et vissez le brunette 1x(**C**) et collez **1** l'adhésif.

09

PASSO 09

Encaixar lateral **04** e parafusar castanhas 1x(**C**) e colar **1** adesivos.

STEP 09

Attach side **04** and screw nuts 1x(**C**) and place **1** stickers.

PASO 09



Montar la lateral **04** y atornillar las tuercas 1x(**C**) y pegar **1** adhesivos.

ÉTAPE 09

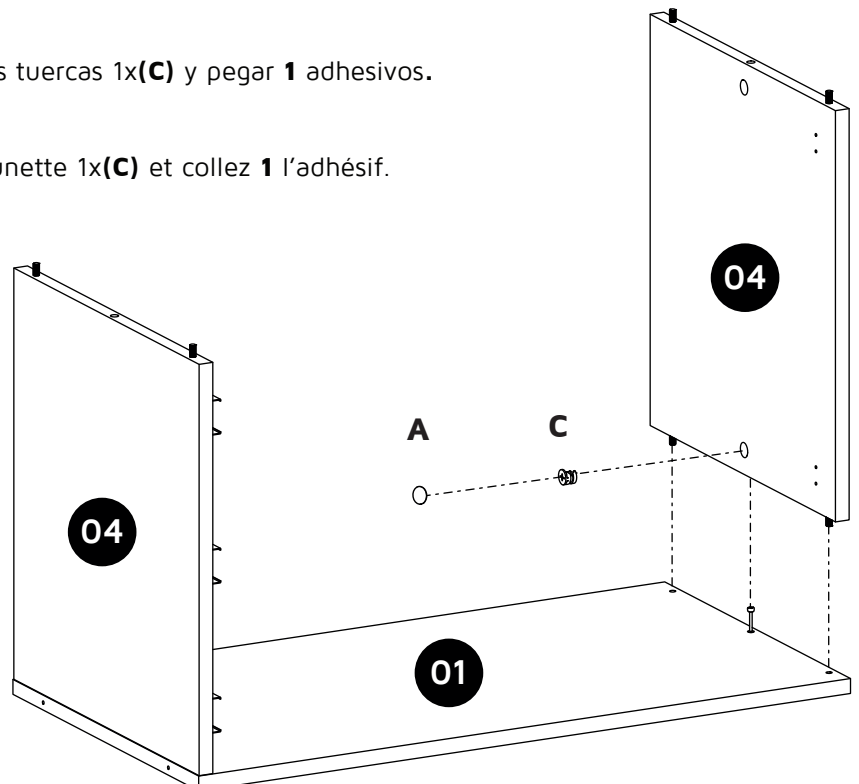
Insérez le côté **04** et vissez le brunette 1x(**C**) et collez **1** l'adhésif.

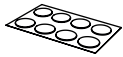

10

A 	C COD. 10063 	N COD. 0357 
---	---	--

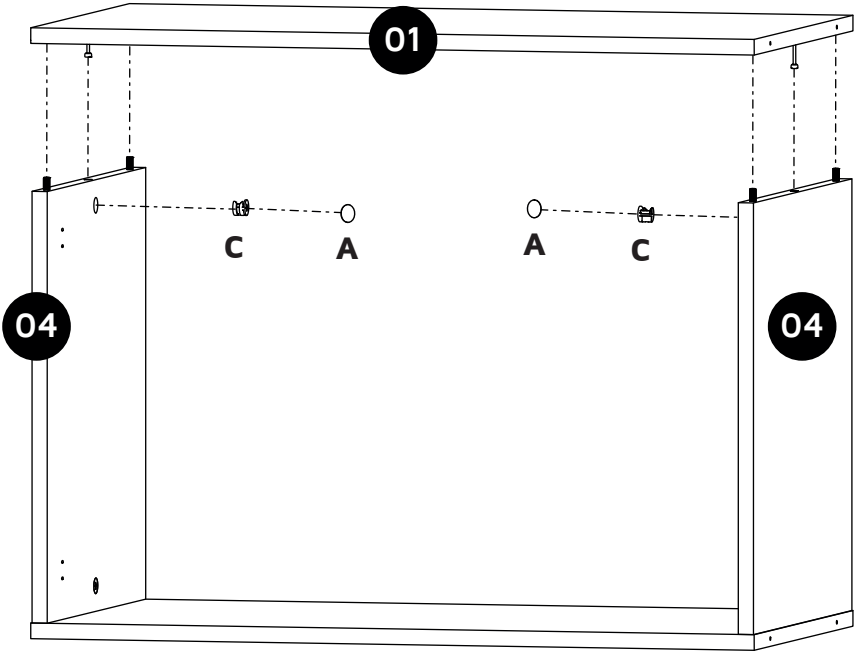

PASSO 10
Encaixar base/tampo **01** e parafusar castanhas 2x(**C**) e colar **2** adesivos.

STEP 10
Attach base/top panel **01**, screw nuts 2x(**C**) and place **2** stickers.

PASO 10
Montar a base/cubierta **01**, atornillar las tuercas 2x(**C**) y pegar **2** adhesivos.

ÉTAPE 10
Insérez la base/plateau **01**, vissez le brunette 2x(**C**) et collez **2** l'adhésif.

11

PASSO 11
Encaixar fundo **06** e pregar 14x(**N**).

STEP 11
Attach backplate **06** and nailing 14x(**N**).

PASO 11
Enganchar el fondo **06** y clavar 14x(**N**).

ÉTAPE 11
Insérez le fond **06** et clouer 14x(**N**).

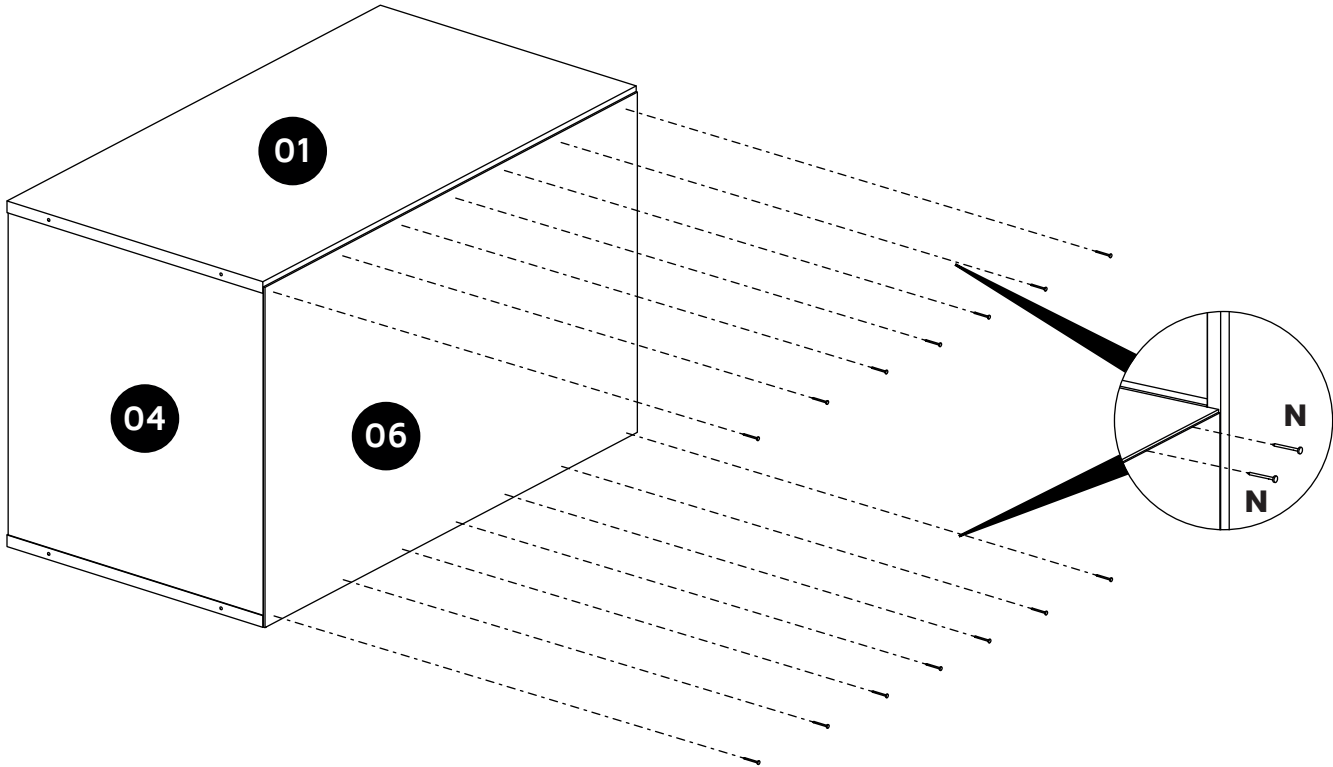

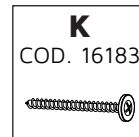
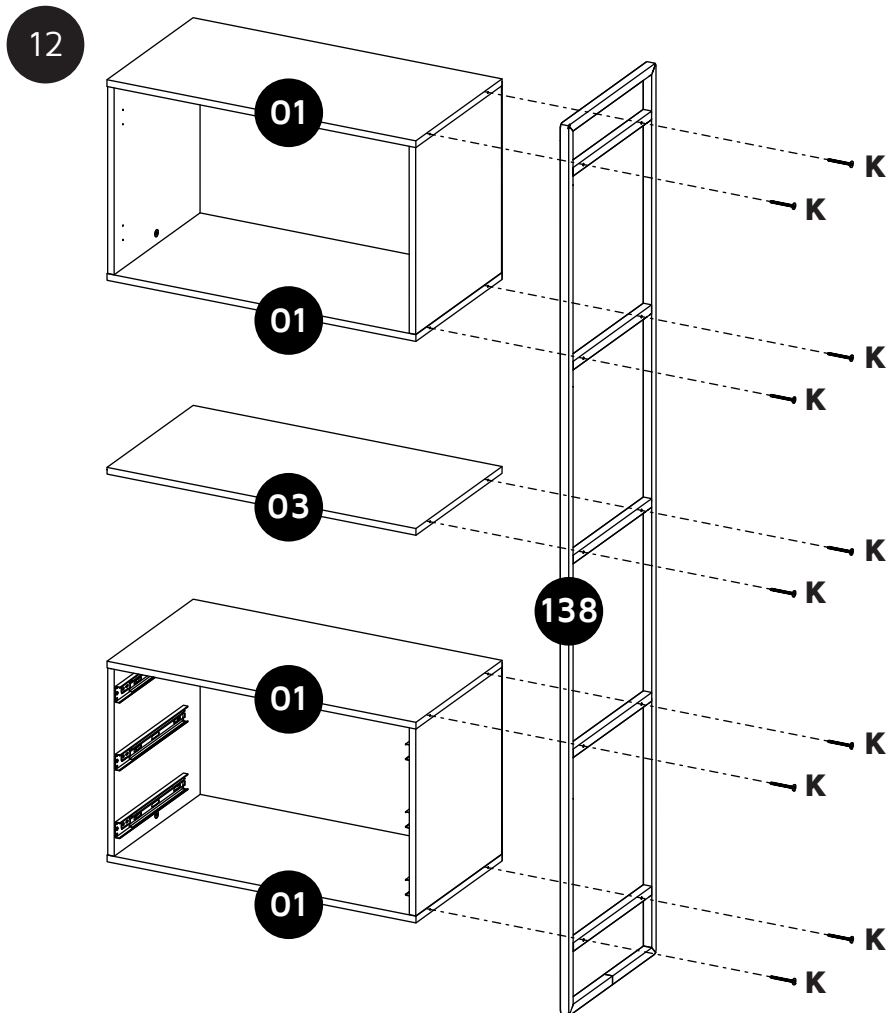

PASSO 12
Encaixar base/tampo **01** e prateleira **03** na base **138** e parafusar 10x(**K**).

STEP 12
Attach base/top panel **01** and top shelf **03** on base **138** and screw 10x(**K**).

PASO 12
Montar a base/cubierta **01** y estante **03** en la base **138** y atornillar 10x(**K**).

ÉTAPE 12
Insérez la base/plateau **01** et étagère **03** dans la base **138** et vissez 10x(**K**).

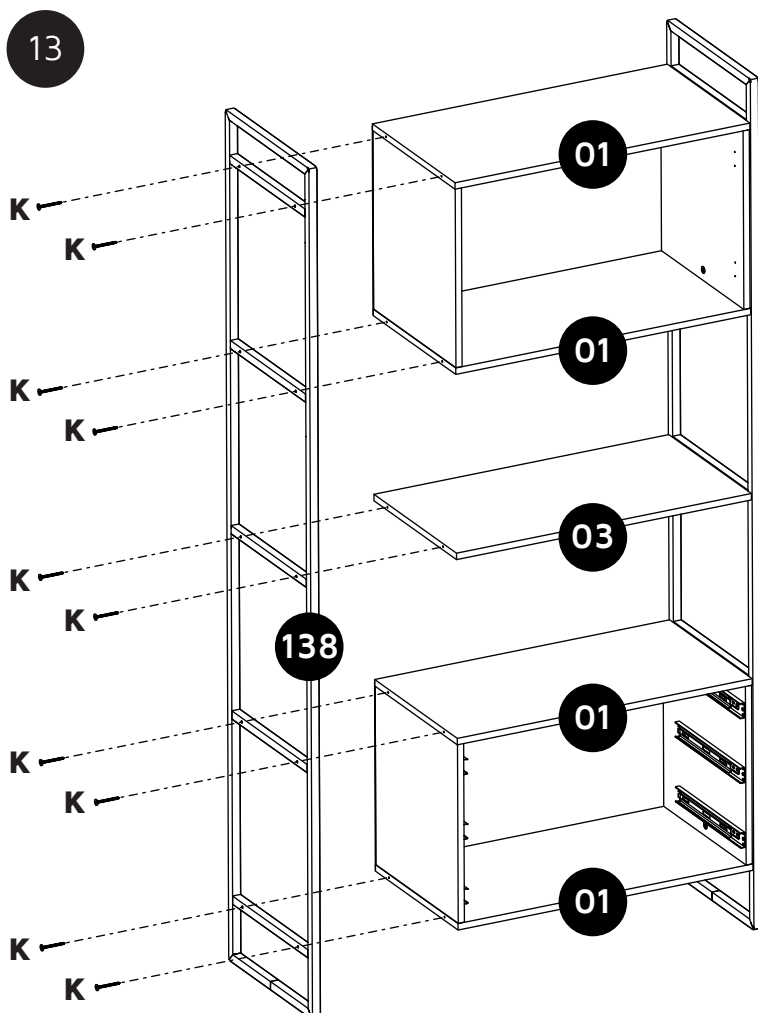







PASSO 13
Encaixar base/tampo **01** e prateleira **03** na base **138** e parafusar 10x(**K**).

STEP 13
Attach base/top panel **01** and top shelf **03** on base **138** and screw 10x(**K**).

PASO 13
Montar a base/cubierta **01** y estante **03** en la base **138** y atornillar 10x(**K**).

ÉTAPE 13
Insérez la base/plateau **01** et étagère **03** dans la base **138** et vissez 10x(**K**).

14

B COD. 12925	F COD. 2511	I COD. 7519	L COD. 3187	M	O COD. 11588
					

PASSO 14
Encaixar 4x(**B**) e sapata 4x(**O**)
na base **138**.

STEP 14
Attach 4x(**B**) and plastic topper 4x(**O**)
in base **138**.

PASO 14
Enganchar 4x(**B**) y almohadilla de plástico
4x(**O**) en la base **138**.

ÉTAPE 14
Insérez 4x(**B**) et le touchon plastique 4x(**O**)
dans la base **138**.

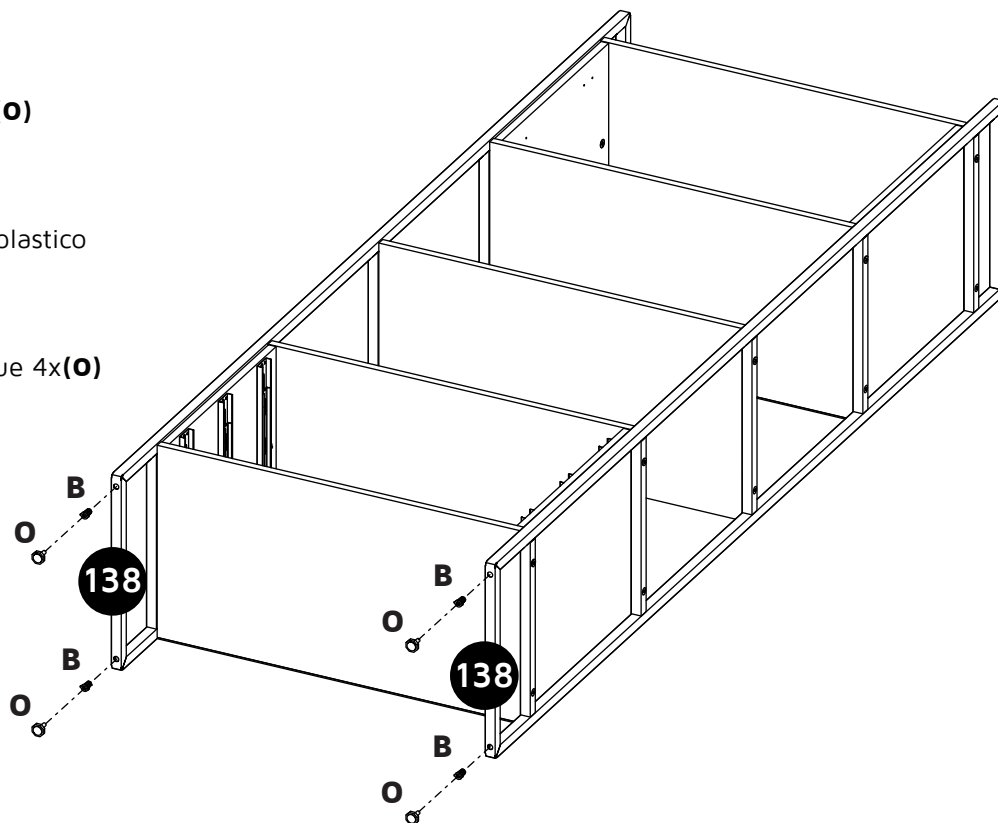

15

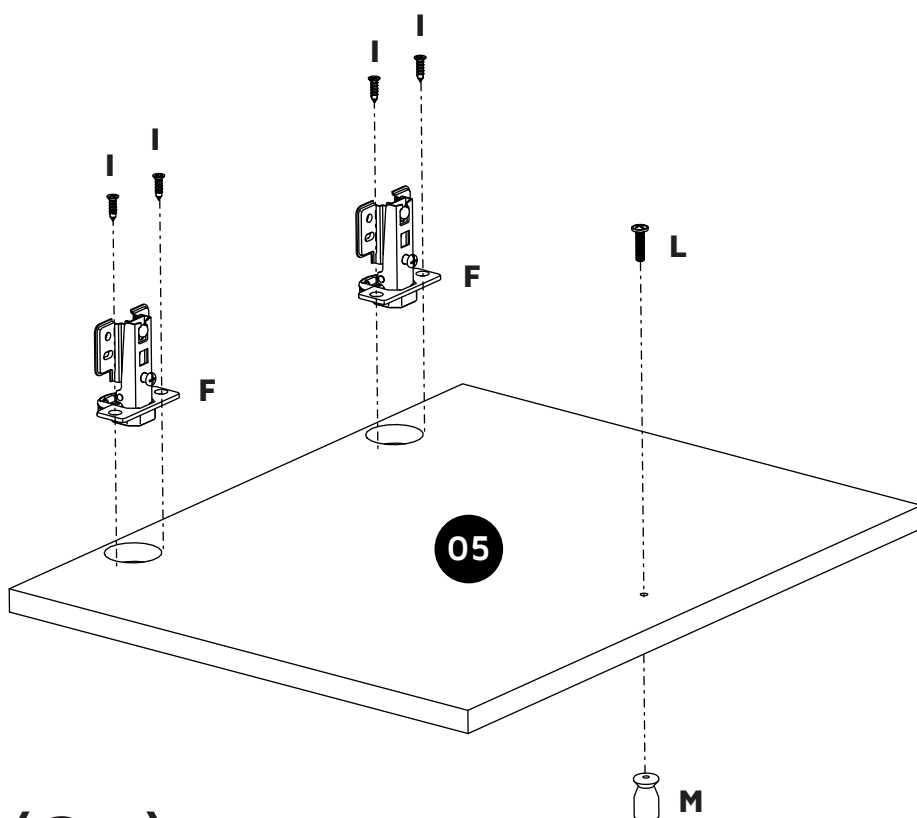

PASSO 15
Encaixar dobradiças 2x(**F**)
e parafusar 4x(**I**). Montar
puxador 1x(**M**) na porta **05**.





STEP 15
Attach the hinges 2x(**F**) and
screw 4x(**I**). Attach door
handle 1x(**M**) at the door **05**.

PASO 15
Montar las bisagras 2x(**F**) y
atornillar 4x(**I**). Montar la
manija 1x(**M**) en la puerta **05**.

ÉTAPE 15
Insérez les charnières 2x(**F**) et
vissez 4x(**I**). Insérez poignée
1x(**M**) et porte **05**.

(2x)

16

D	E	H	J
COD. 1668	COD. 13579	COD. 1533	COD. 0715
			

PASSO 16

Parafusar 4x(H) as corredeiras 2x(E) nas laterais gaveta esquerda e direita **61/62**.

PASO 16

Atornillar 4x(H) las correderas 2x(E) en los cajóns laterales izquierda y derecha **61/62**.

STEP 16

Screw 4x(H) the slides 2x(E) on the left and right drawer side **61/62**.

ÉTAPE 16

Vissez 4x(H) les curseurs 2x(E) sur les tiroir latéral gauche et droit **61/62**.

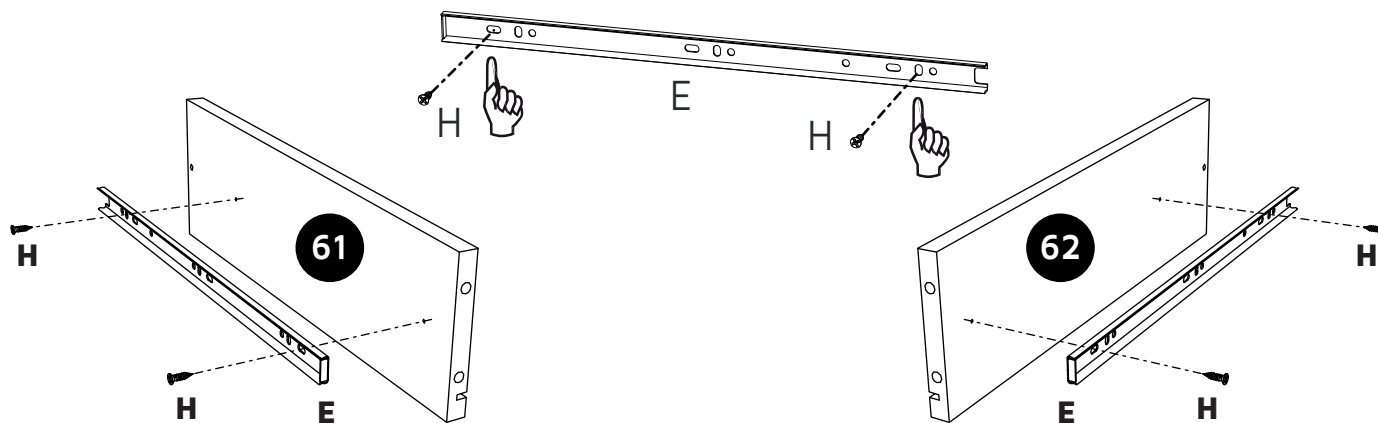

(3x)

17

PASSO 17

Encaixar cavilhas 4x(D) no contra fundo **63**.
Encaixar laterais gaveta esquerda e direita **61/62** no contra fundo **63** e parafusar 2x(J).

PASO 17

Clavijas de ajuste 4x(D) en cajón inferior **63**.
Montar cajóns laterales izquierda y derecha **61/62** en lo cajón inferior **63** y atornillar 2x(J).

STEP 17

Insert dowels 4x(D) on drawer back panel **63**.
Attach left and right drawer side **61/62** on the drawer back panel **63** and screw 2x(J).

ÉTAPE 17

Insérez les chevilles 4x(D) derrière **63**.
Insérez tiroir latéral gauche et droit **61/62** dans derrière **63** et vissez 2x(J).

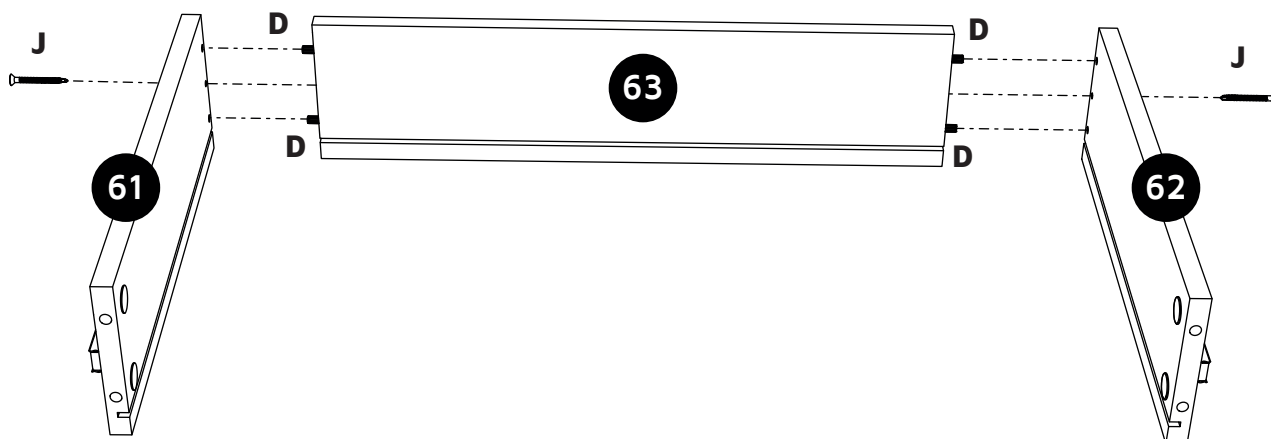

(3x)

18

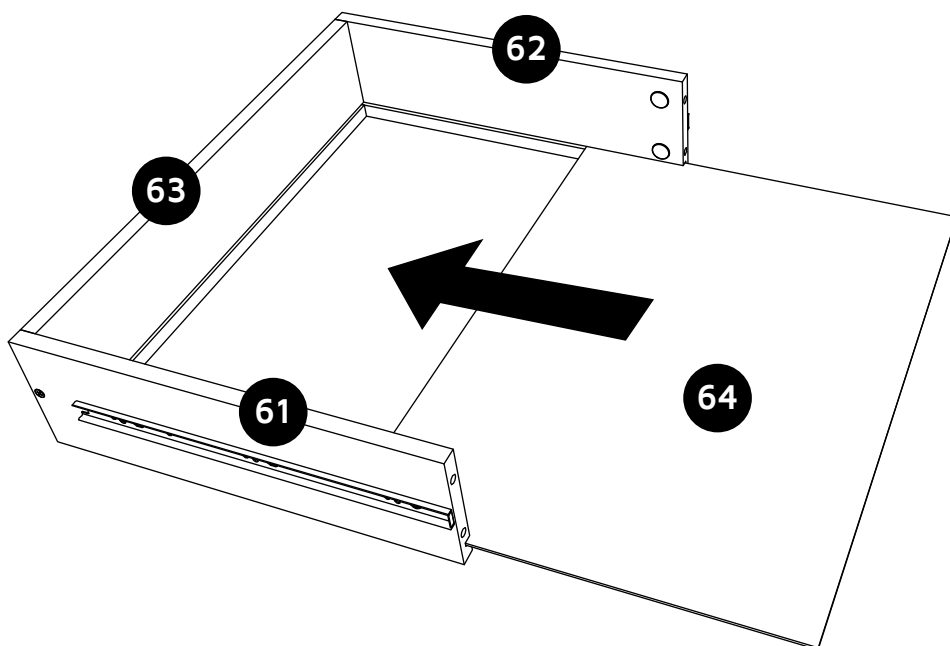
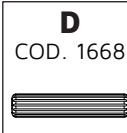

PASSO 18
Encaixar fundo gaveta **64**.

STEP 18
Attach drawer bottom **64**.

PASO 18
Montar fondo del cajon **64**.

ÉTAPE 18
Insérez fond de tiroir **64**.

(3x)

19

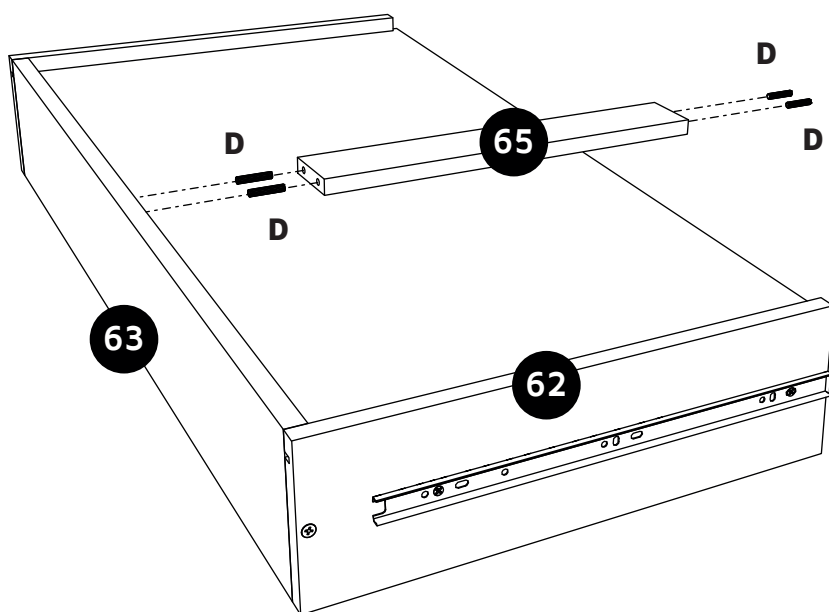

PASSO 19
Encaixar cavilhas 4x(**D**) na travessa gaveta **65** e montar no contra fundo **63**.





STEP 19
Insert dowels 4x(**D**) on drawer crosspiece **65** and attach on drawer back panel **63**.

PASO 19
Clavijas de ajuste 4x(**D**) en el travesaño cajón **65** y montar en el cajón inferior **63**.

ÉTAPE 19
Insérez les chevilles 4x(**D**) barreau **65** et insérez dans derrière **63**.

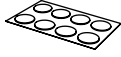
(3x)

20

A 	C COD. 10063 	G COD. 0599 	L COD. 3187 	M 
---	---	--	--	---

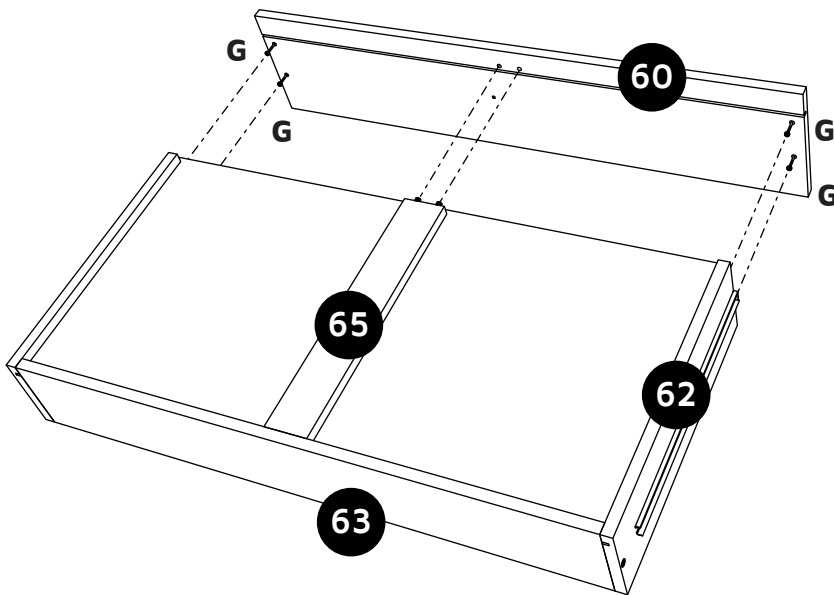

PASSO 20
Parafusar minifix 4x(**G**) na frente gaveta **60** e encaixar nas laterais **61/62**.

STEP 20
Screw minifix 4x(**G**) on drawer front **60** and attach on sides **61/62**.

PASO 20
Atornillar el minifix 4x(**G**) en la frente del cajón **60** y montar en las laterales **61/62**.

ÉTAPE 20
Vissez le minifix 4x(**G**) dans la façade de tiroir **60** et insérez dans côtés **61/62**.

(3x)

21

PASSO 21
Encaixar frente gaveta **60**, parafusar castanhas 4x(**C**) e colar 4 adesivos. Parafusar 1x(**M**) o puxador.

STEP 21
Attach drawer front **60**, screw nuts 4x(**C**) and place 4 stickers. Screw 1x(**M**) the door handle.

PASO 21
Montar frente del cajón **60**, atornillar las tuercas 4x(**C**) y pegar 4 adhesivo. Atornillar 1x(**M**) el manija.

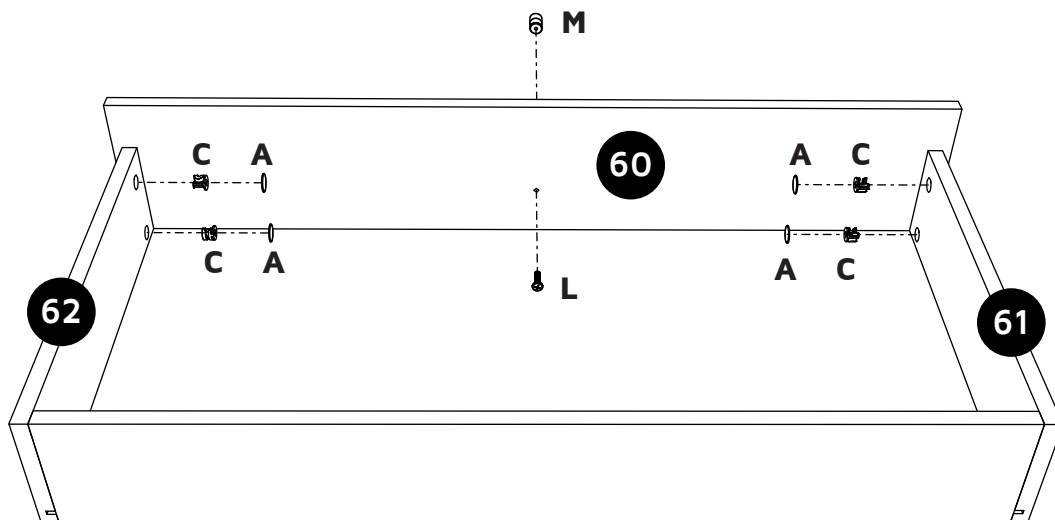

ÉTAPE 21
Insérez façade de tiroir **60**, vissez le brunette 4x(**C**) et collez 4 l'adhésif. Vissez 1x(**M**) et poignée.



(3x)

22

AJUSTE DAS DOBRADIÇAS
HINGE ADJUSTMENT
AJUSTE DE LAS BISAGRAS
RÉGLAGE DES CHARNIÈRES

F COD. 2511	I COD. 7519
	

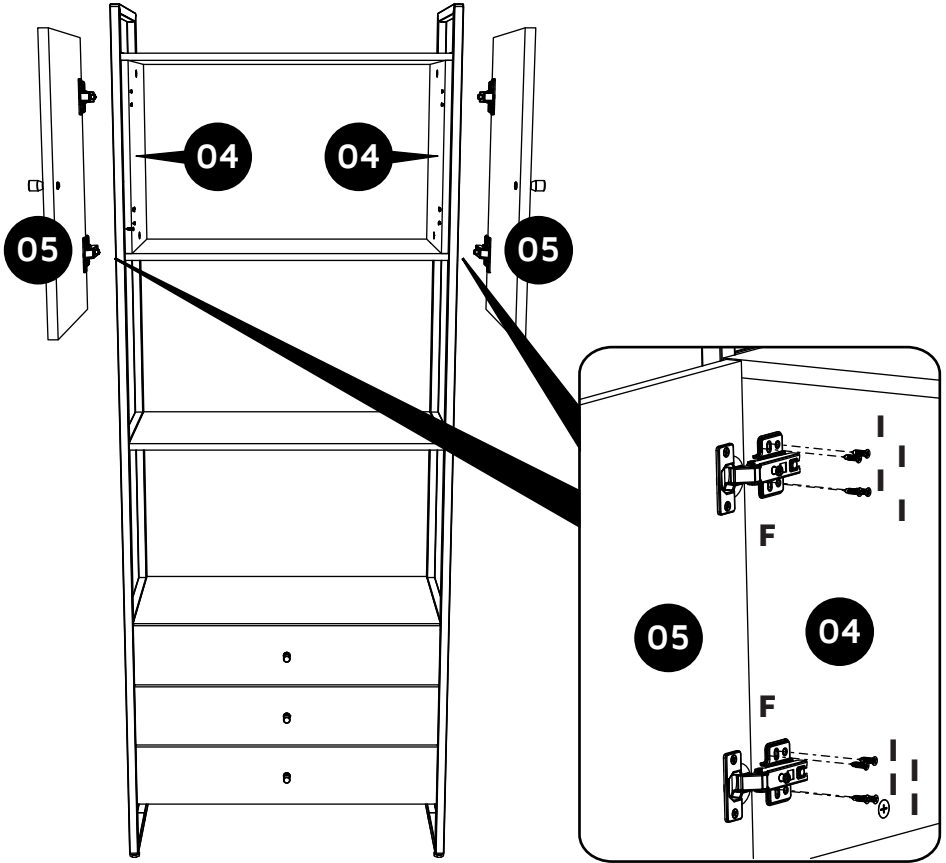
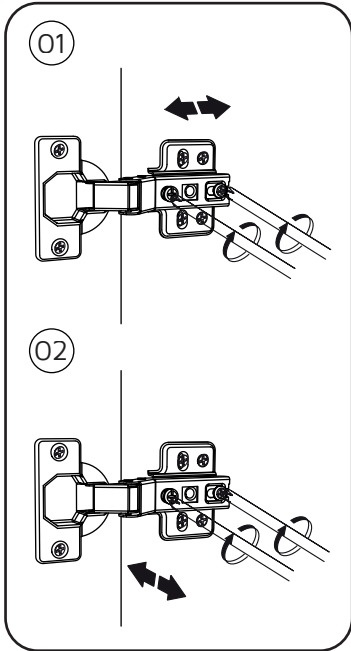

23

