

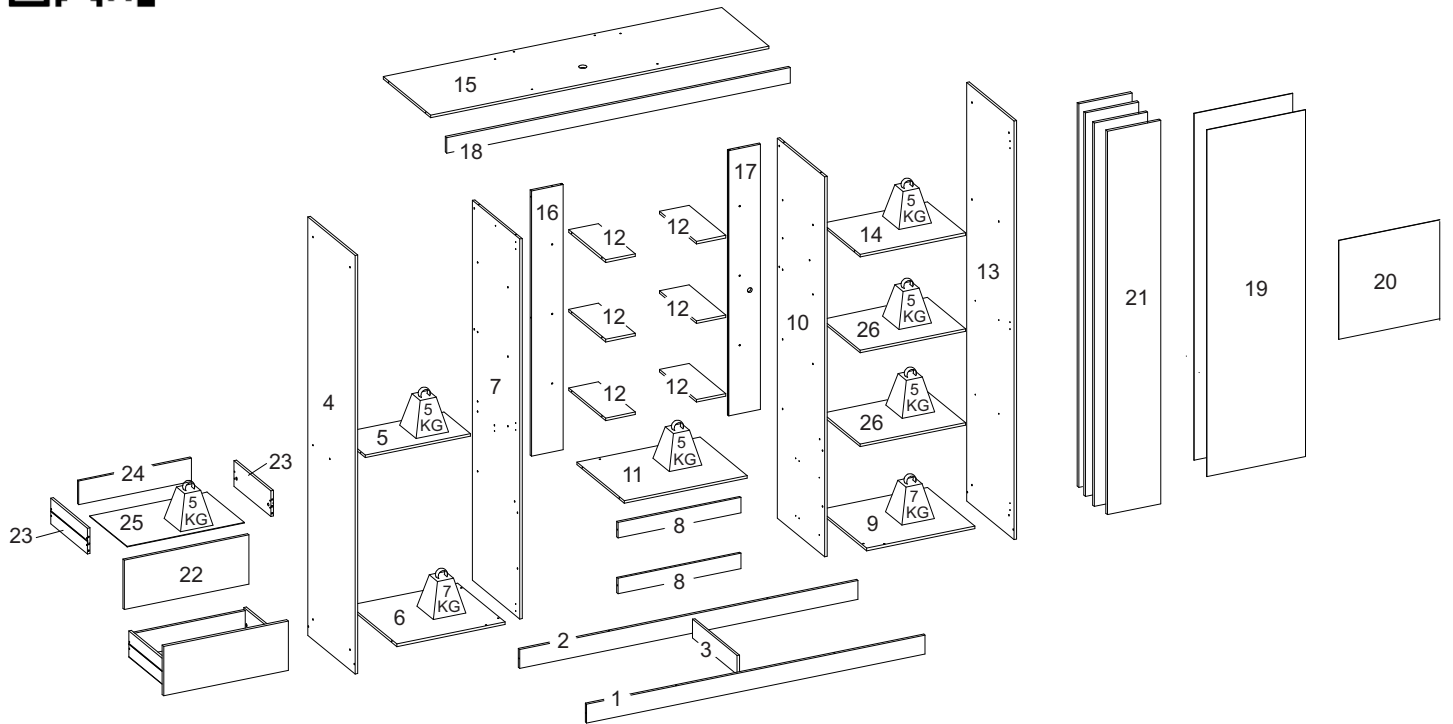

236 - GR OLIMPIA



LISTA DE PEÇAS / PIECES LIST / LISTA DE PIEZAS

SEQ.	REF.	DESCRIÇÃO	DESCRIPTION	DESCRIPCIÓN	MAT.PRIMA	COMP.	LARG.	ESP.	QTD.
1	332252	Rodapé frontal	Front footer	Pie de página frontal	MDP	1608	88	12	1
2	332253	Rodapé traseiro	Back footer	Pie de página posterior	MDP	1608	88	12	1
3	332254	Trava rodapé	Footer lock	Bloqueo de pie de página	MDP	424	88	12	1
4	332255	Lateral esquerda	Left side	Lado izquierdo	MDP	1950	450	12	1
5	332256	Prateleira menor	Smaller shelf	Estante más pequeño	MDP	500	254	12	1
6	332257	Base esquerda	Left base	base izquierda	MDP	515	450	12	1
7	332258	Divisória esquerda	Left divider	divisor izquierdo	MDP	1770	450	12	1
8	332259	Vista gaveta	Drawer view	Vista del cajón	MDP	584	72	12	2
9	332260	Base direita	Right base	base derecha	MDP	515	450	12	1
10	332261	Divisória direita	Right divider	divisor derecho	MDP	1770	450	12	1
11	332262	Tampo gaveteiro	Drawer top	Tapa del cajón	MDP	584	450	12	1
12	332263	Prateleira nicho	Niche shelf	Estantería nicho	MDP	351	140	12	6
13	332264	Lateral direita	Right side	Lado derecho	MDP	1950	450	12	1
14	332265	Prateleira superior	Top shelf	estante superior	MDP	500	360	12	1
15	332266	Chapéu	Hat	Sombrero	MDP	1608	450	12	1
16	332267	Painel espelho esquerdo	Left mirror panel	Panel izquierdo del retrovisor	MDP	1236	150	12	1
17	332268	Painel espelho direito	Right mirror panel	Panel derecho del retrovisor	MDP	1236	150	12	1
18	332269	Vista superior	Upper view	Vista superior	MDP	1632	72	15	1
19	332270	Fundo	Bottom	Abajo	HDF	1791	519	3	2
20	332271	Fundo central	Central fund	Fondo central	HDF	590	566	3	1
21	332272	Porta	Door	Puerta	MDP	1786	253	15	4
22	332273	Frente de gaveta	Drawer front	Frente del cajón	MDP	592	230	15	2
23	332274	Lateral de gaveta	Drawer side	Lado del cajón	MDP	350	120	12	4
24	332275	Contra fundo	Against background	Contra el fondo	MDP	535	110	12	2
25	332276	Fundo da gaveta	Drawer bottom	Fondo del cajón	HDF	557	355	3	2
26	332277	Prateleira móvel	Mobile shelf	Estante móvil	MDP	500	360	12	2

INSTRUÇÃO MONTAGEM PRODUTO

Intructions to Assembly / Instrucciones de montaje

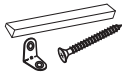

Separate the parts and accessories in an organized way.
Separate parts and accessories in way organized
Separe las piezas y accesorios de manera organizada

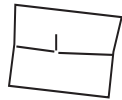

Line the floor with the cardboard from the packaging.
Cover the floor with the cardboard
Cubra el suelo con la embalaje de cartón



It is necessary 01 person to assemble the product.
01 people are required to assemble the product
Se requieren 01 persona para ensamblar el producto

The product must be assembled by a professional.
The product must be assembled by a professional
El producto debe ser ensamblado por un profesional calificado

Tools required (not provided)

Not include tools / No herramientas



CUIDADO PARA CONSERVAÇÃO E LIMPEZA DO MÓVEL

Care to conservation and clean / Cuidados de limpieza

Maximum load weight information refers to objects distributed evenly over the entire contact area of the part.



The maximum load weight information refers to objects distributed evenly over the entire contact area of the part.
Conjunto de carga máxima de peso se refiere a objetos distribuidos uniformemente sobre toda el área de contacto de la pieza de trabajo.



Do not wet the furniture and do not expose it in a wet place.
Do not wet the mobile and do not expose in a wet place
No moje el producto y no exponer en un lugar húmedo



Do not expose the furniture near heat sources.
Do not expose the mobile near heat sources
no exponga cercano de fuentes de calor



Do not use abrasive products.
Do not use abrasive products.
No utilice productos abrasivos.



Clean with a dry cloth.
Clean with dry cloth
Limpieza con un paño limpio y seco



For cleaning the stamps on the pieces, use a school eraser (item not provided).
Para limpiar los sellos de las piezas, utilice un borrador escolar (artículo no incluido)

Para limpiar los sellos de las piezas, utilice un borrador escolar (artículo no incluido)

LISTA DE ACESSÓRIOS E FERRAGENS / ACCESSORIES AND HARDWARE / ACCESORIOS Y HARDWARE

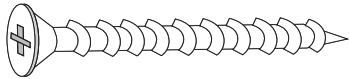

A - 700137-Parafuso 4,5x45 (60x)
screw / tornillo



B- 700124-Parafuso 3,5x25 (16x)
screw / tornillo



C- 700121-Parafuso 3,5x12 (107x)
screw / tornillo

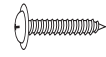

D- 700127-Parafuso 4,0x12 (48x)
screw / tornillo



E- 700130-Parafuso 4,0x16 (8x)
screw / tornillo



F- 700157-Prego (108x)
nail / clavo



G- 700542-Cavilha 6x30 (14x)
peg / cerrojo



H- 700146-Parafuso minifix (4x)
Minifix screw /
Tornillo minifix



I- 700148-Tambor Minifix (04x)
Minifix Drum / Tambor minifix



J - 700113-Corrediça (2x)
runners / corredera



K - 700539-Cantoneira (12x)
corner / esquina



L - 700438 - Suporte cabide (4X)
hook support / soporte gancho

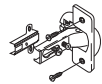

M- 700395 - Dobradiça (12x)
700390 - Calço (12x)
hinge / bisagra

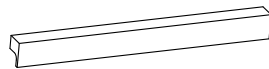

N- 700171-Puxador 250 mm (4x)
Handle / Manija



O - 700441 - Suporte prateleira(8x)
Support/apoyo



P- 700419-Tapa furo (8x)
cover / tapa



Q - 700490 - Kit com 6 Pes (1x)
foot / pie



R- 700516 - Cola (1x)
glue / pegamento



S - 703270 - Cabideiro Alumínio (2x)
Coat Rack / Perchero

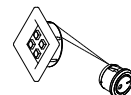

T - 700586 - Kit Luminária (1x)
Luminaire kit/Kit de iluminación



U - 703268 - Espelho (1X)
Mirror/Espejo



V- 700419-Tapa furo (20x)
cover / tapa

01° PASSO - Fixar os acessórios D + M na peça 21.

01° STEP - Fix fittings D + M to part 21.

01° PASO - Fijar los racores D + M a la pieza 21.

D



M

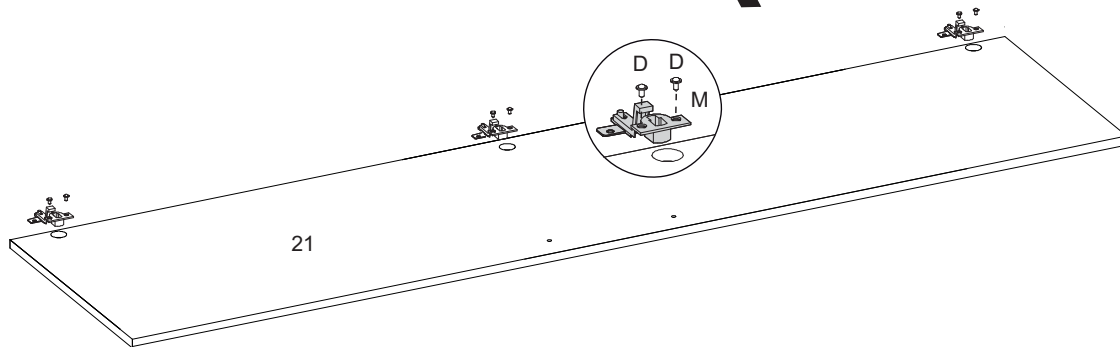
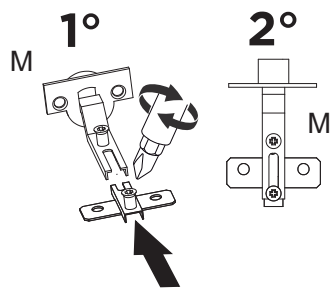

02° PASSO - Fixar os acessórios C + J nas peças 7 e 10.

02° STEP - Fix fittings C + J to parts 7 and 10.

02° PASO - Fijar los racores C + J a las piezas 7 y 10.

C



J

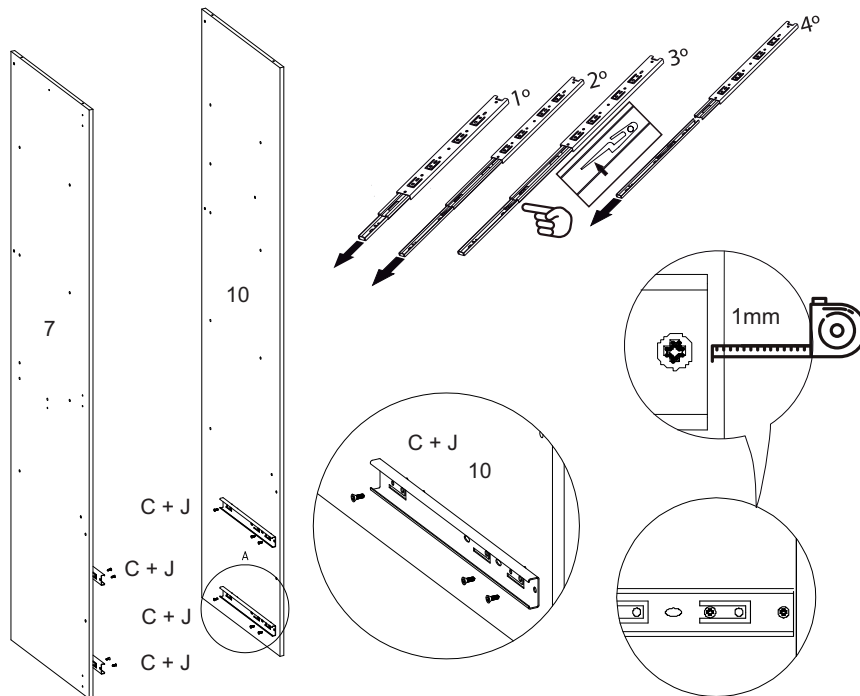

03° PASSO - Fixar a peça 6 na peça 7 e peça 9 na peça 10.

03° STEP - Fix part 6 to part 7 and part 9 to part 10.

03° PASO - Adjunte la parte 6 a la parte 7 y la parte 9 a la parte 10.

A

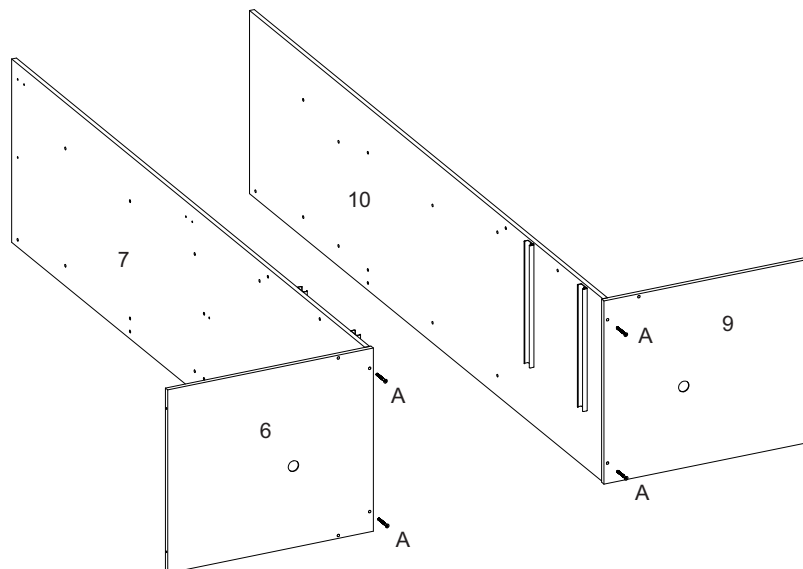

04° PASSO - Fixar a peça 3 nas peças 1 e 2 e fixar o acessório Q.

04° STEP - Fix part 3 to parts 1 and 2 and attach accessory Q.

04° PASO - Fijar la pieza 3 a las piezas 1 y 2 y coloque el accesorio Q.

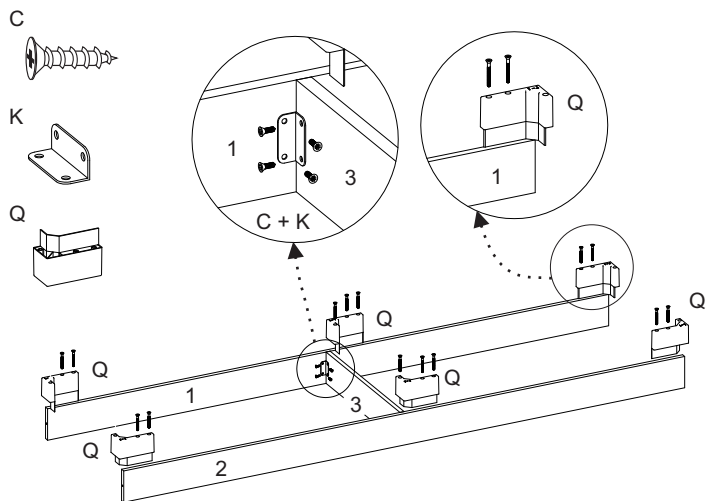

05° PASSO - Fixar a peça 4 nas peças 1, 2 e 5.

05° STEP - Fix part 4 to parts 1, 2 and 5.

05° PASO - Fixar la parte 4 a las partes 1, 2 y 5.

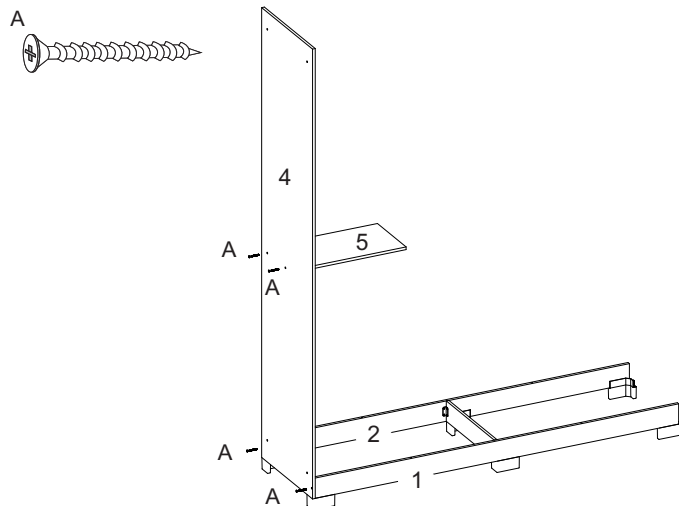

06° PASSO - Fixar a peça 7 + 6 nas peças 1, 2 e 5.

06° STEP - Fix part 7 + 6 to parts 1, 2 and 5.

06° PASO - Fijar la parte 7 + 6 a las partes 1, 2 y 5.

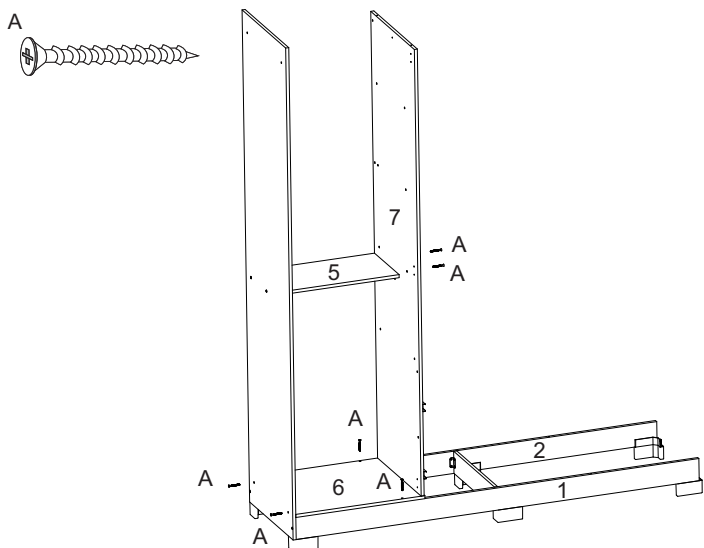

07° PASSO - Fixar a peça 8 na peça 7.

07° STEP - Fix part 8 to part 7.

07° PASO - Fijar la parte 8 a la parte 7.

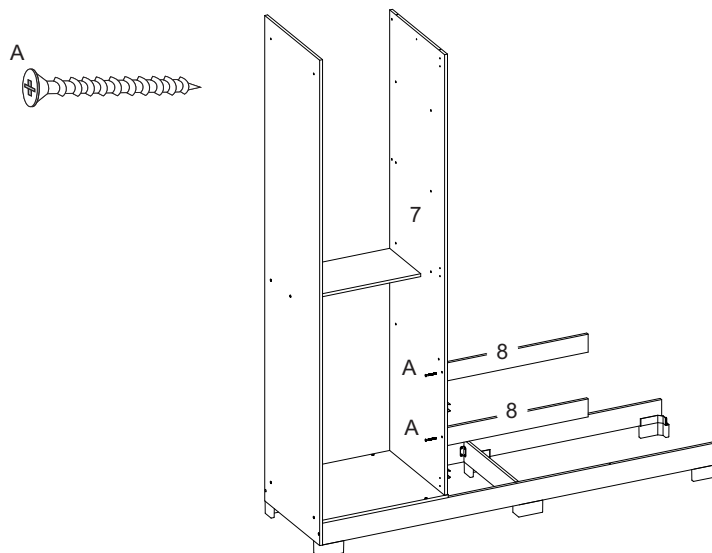

08° PASSO - Fixar a peça 13 nas peças 1 e 2.

08° STEP - Fix part 13 to parts 1 and 2.

08° PASO - Fijar la parte 13 a las partes 1 y 2.

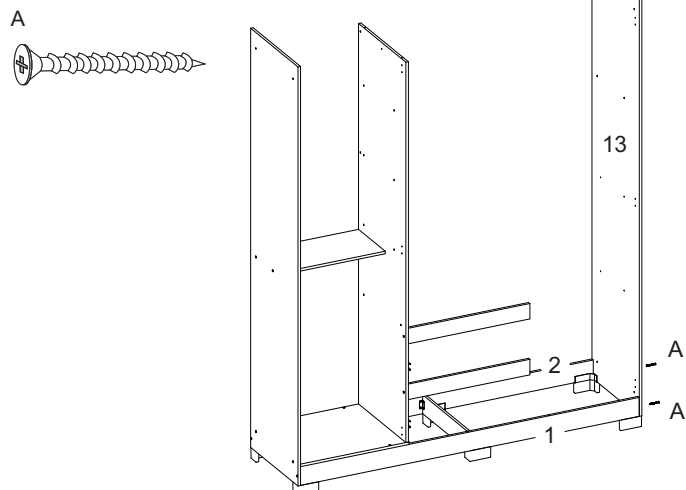

09° PASSO - Fixar a peça 9 + 10 na peça 8.

09° STEP - Fix part 9 + 10 to part 8.

09° PASO - Fijar la parte 9 + 10 a la parte 8.

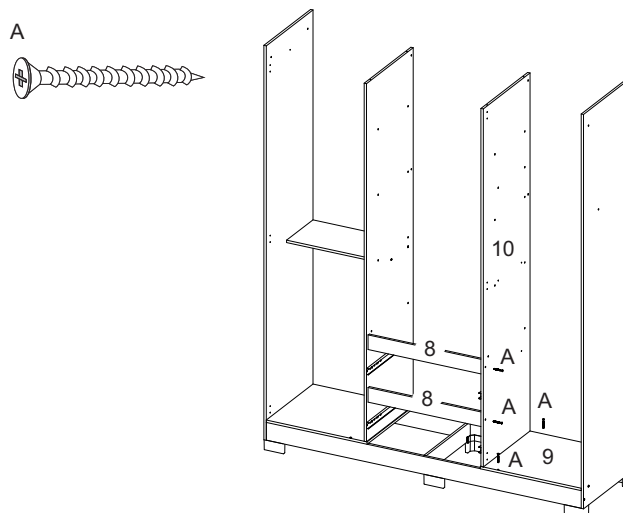

10° PASSO - Fixar o acessório C + K na peça 8.

10° STEP - Fix accessory C + K to part 8.

10° PASO - Fijar el accesorio C + K a la pieza 8.

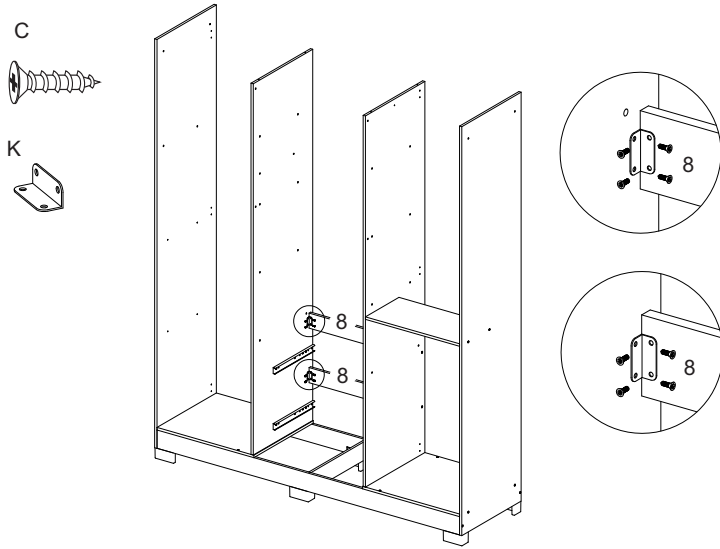

11° PASSO - Fixar a peça 11 nas peças 7 e 10.

11° STEP - Fix part 11 to parts 7 and 10.

11° PASO - Fijar la parte 11 a las partes 7 y 10.

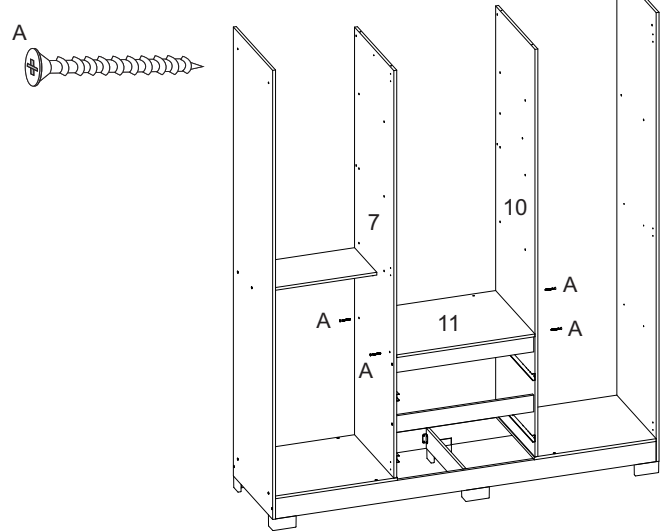

12° PASSO - Fixar a peça 12 nas peças 7 e 10 e o acessório G na peça 12.

12° STEP - Fix part 12 to parts 7 and 10 and accessory G to part 12.

12° PASO - Fijar la pieza 12 a las piezas 7 y 10 y el accesorio G a la pieza 12.

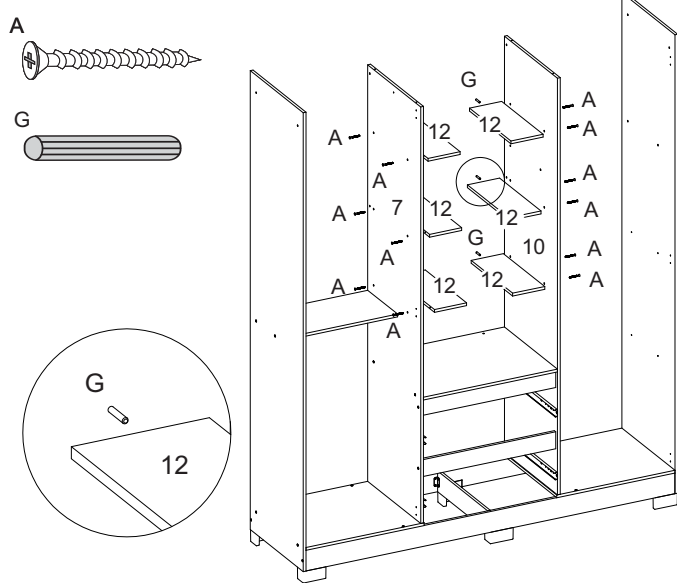

13° PASSO - Fixar a peça 14 nas peças 10 e 13 e o acessório E + O nas peças 10 e 13.

13° STEP - Fix part 14 to parts 10 and 13 and accessory E + O to parts 10 e 13.

13° PASO - Fijar la pieza 14 a las piezas 10 y 13 y el accesorio E + O a las piezas 10 e 13.

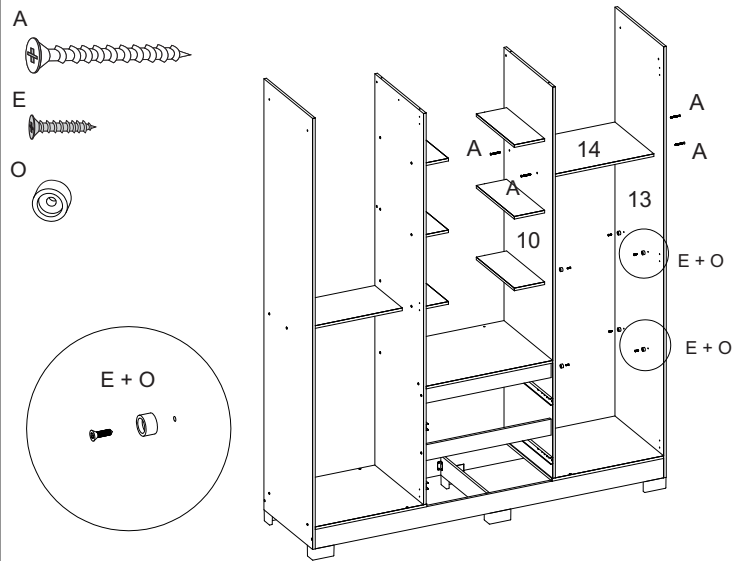

14° PASSO - Fixar a peça 15 nas peças 4, 7, 10 e 13.

14° STEP - Fix part 15 to parts 4, 7, 10 and 13.

14° PASO - Fijar la pieza 15 a las piezas 4, 7, 10 y 13.

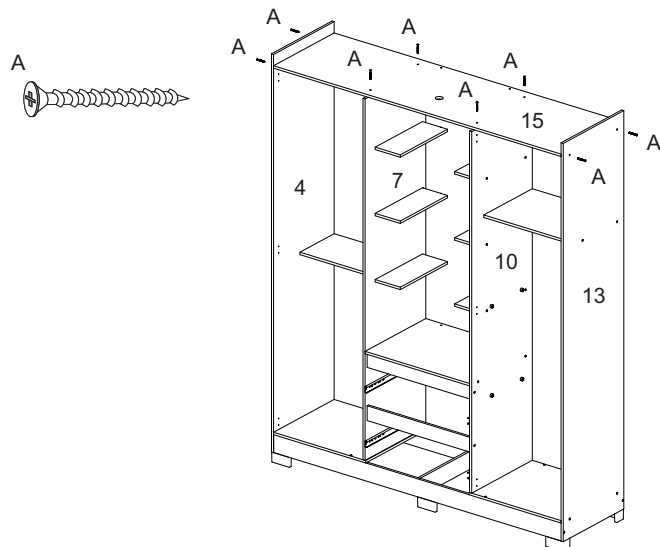

15° PASSO - Encaixar peça 17 nas peças 12.

15° STEP - Fit piece 17 to piece 12.

15° PASO - Encajar la pieza 17 en la pieza 12.

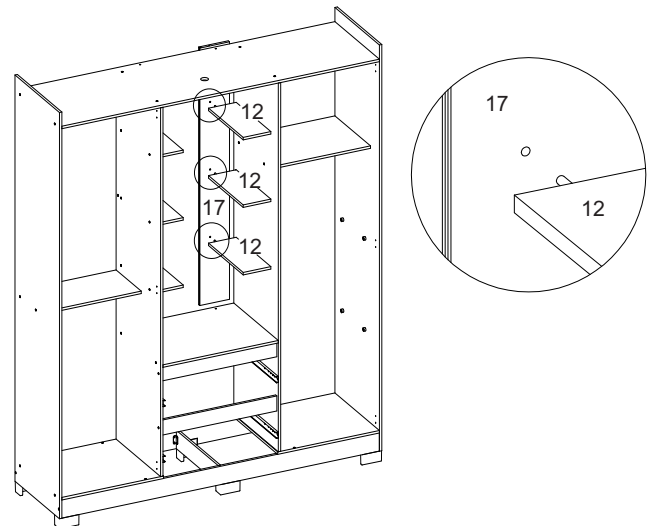

16° PASSO - Fixar a peça 17 nas peças 10 , 11 e 15.

16° STEP - Fix part 17 to parts 10, 11 and 15.

16° PASO - Fijar la pieza 17 a las piezas 10, 11 y 15.

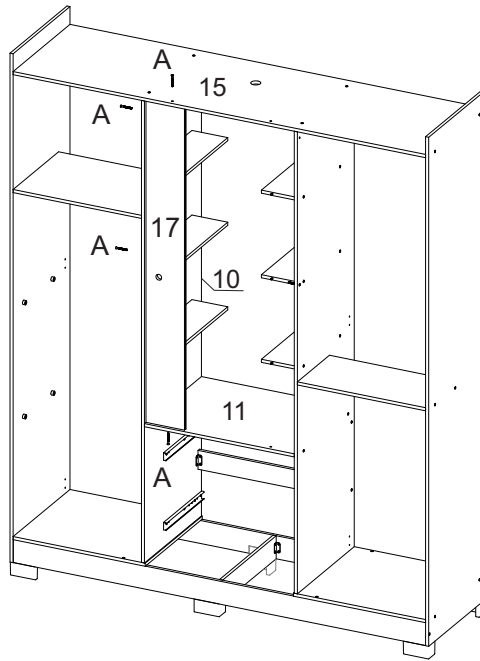
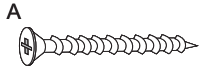

17° PASSO - Encaixar o acessório U no canal da peça 17.

17° STEP - Fit the U fitting into the channel of part 17.

17° PASO - Encajar el racor en U en el canal de la pieza 17.

U

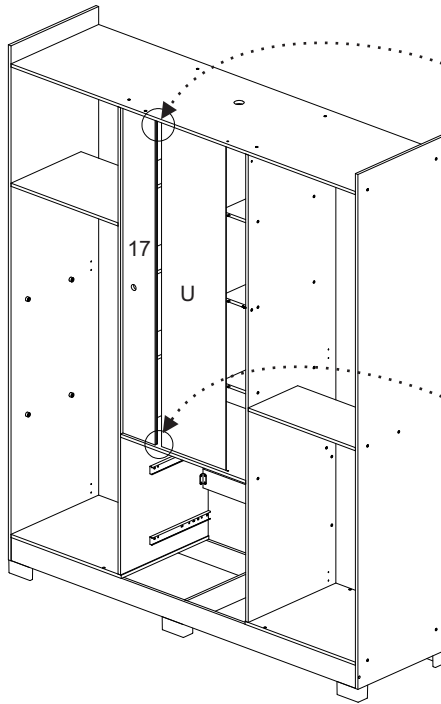

18° PASSO - Encaixar a peça 16 na peça 12 e encaixar acessório U no canal da peça 16.

18° STEP - Fit part 16 to part 12 and fit the U fitting into the channel of part 16.

18° PASO - Encajar la pieza 16 en la pieza 12 y encajar el racor en U en el canal de la pieza 16.

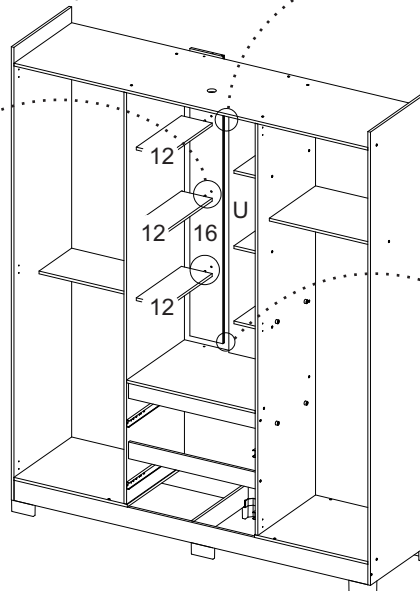
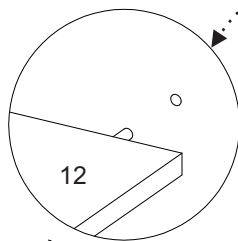

19° PASSO - Fixar a peça 16 nas peças 7, 11 e 15.

19° STEP - Fix part 16 to parts 7, 11 and 15.

19° PASO - Fijar la pieza 16 a las piezas 7, 11 y 15.

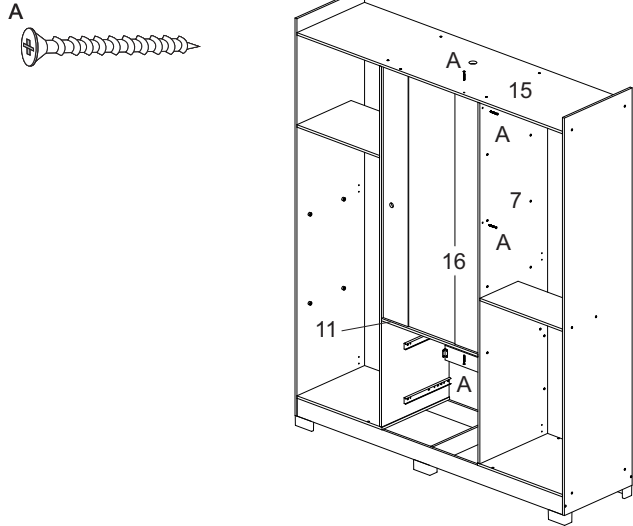

20° PASSO - Fixar o acessório T nas peças 15 e 17.

20° STEP - Fix the T-fitting to parts 15 and 17.

20° PASO - Fijar el racor en T a las piezas 15 y 17.

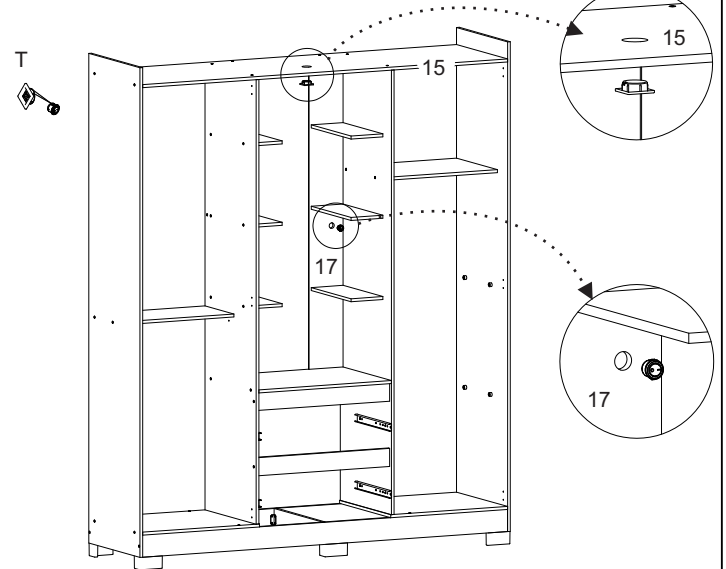

21° PASSO - Fixar a peça 18 nas peças 4 e 13.

21° STEP - Fix part 18 to parts 4 and 13.

21° PASO - Fijar la parte 18 a las partes 4 y 13.

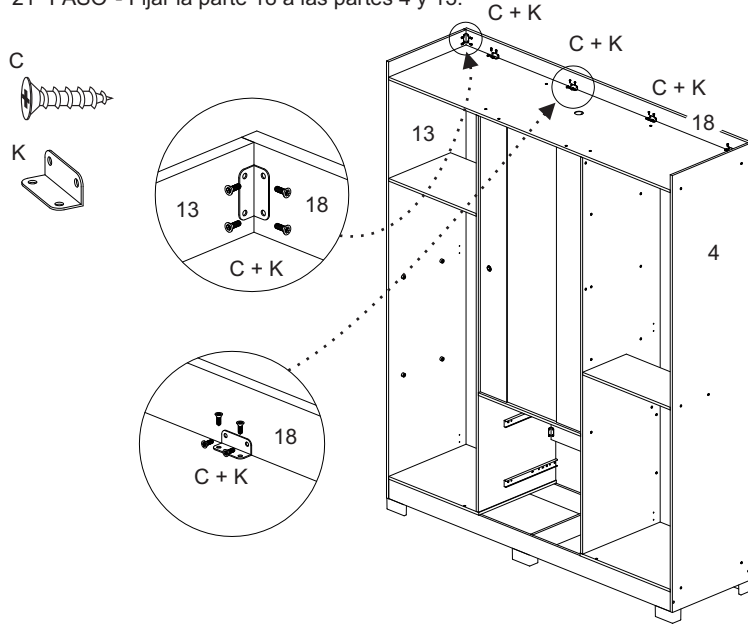

22° PASSO - Fixar as peças 19 e 20 atrás do produto.

22° STEP - Fix parts 19 and 20 behind the product.

22° PASO - Fijar las piezas 19 y 20 detrás del producto.

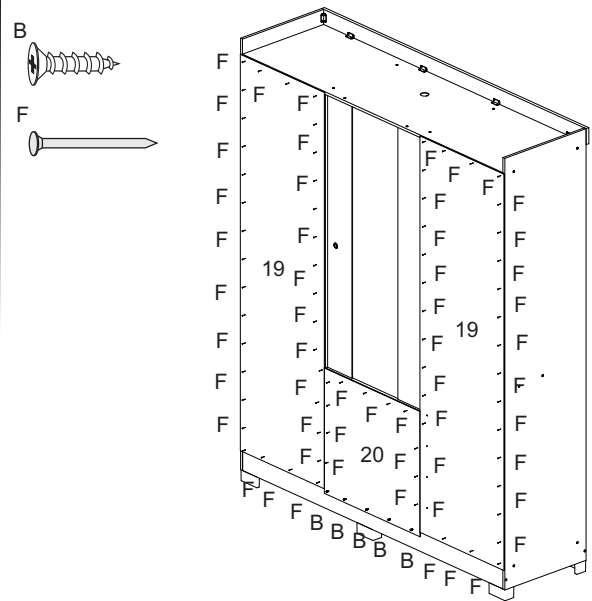

23° PASSO - Fixar o acessório C + L nas peças 4 e 7 e encaixar o acessório S.

23° STEP - Fix accessory C + L to parts 4 and 7 and fit accessory S.

23° PASO - Fijar el accesorio C + L a las piezas 4 y 7 y monte el accesorio S.

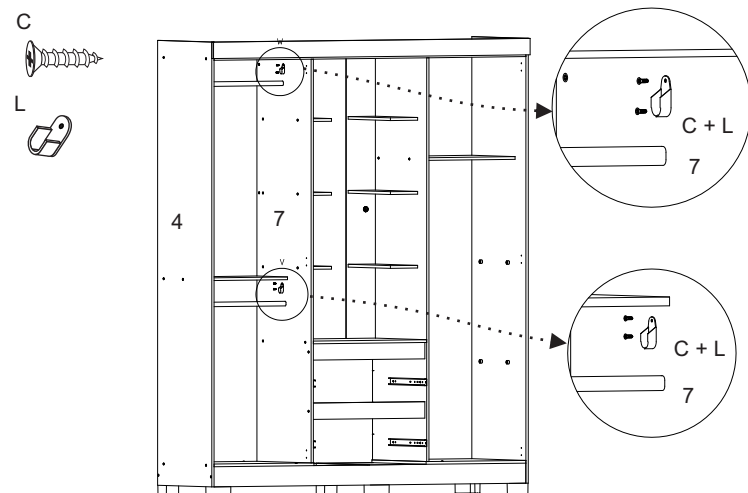

24° PASSO - Apoiar a peça 26 sobre o acessório O.

24° STEP - Support part 26 on accessory O.

24° PASO - Soporte pieza 26 en accesorio O.

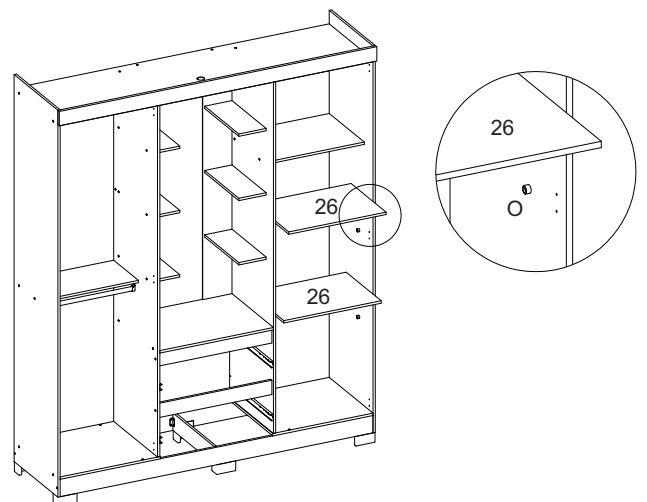

25° PASSO - Fixar a peça 21 nas peças 4,7,10 e 13 e fixar acessório B+N.

25° STEP - Fix part 21 to parts 4, 7, 10 and 13 and attach accessory B+N.

25° PASO - Fijar la pieza 21 a las piezas 4, 7, 10 y 13 y fije el accesorio B+N.

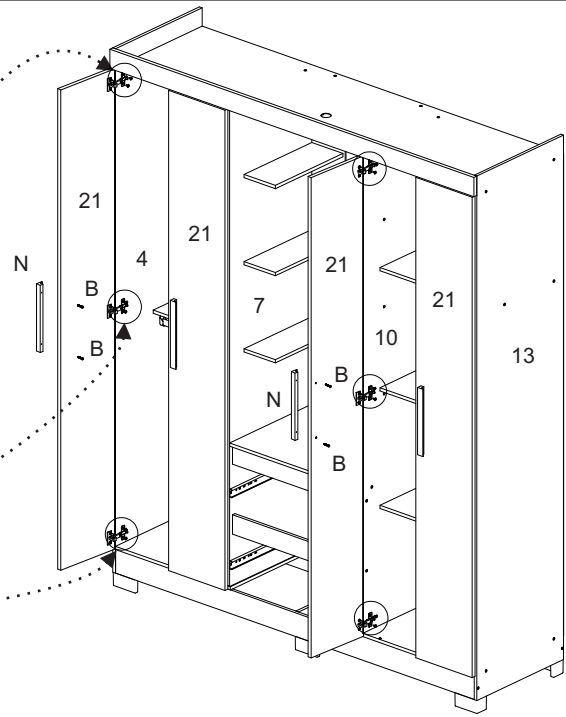
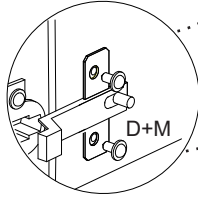
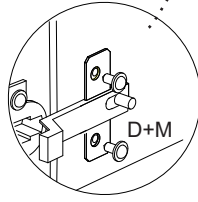
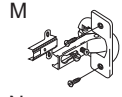
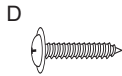

26° PASSO - Fixar a peça 23 nas peças 22 e 24.

26° STEP - Fix part 23 to parts 22 and 24.3.

26° PASO - Fijar la pieza 23 a las piezas 22 y 24.

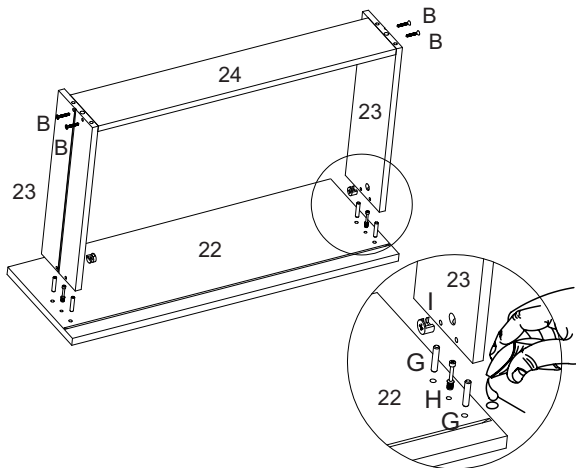

27° PASSO - Fixar a peça 25 nas peças 23 e 24.

27° STEP - Fix part 25 to parts 23 and 24.

27° PASO - Fijar la pieza 25 a las piezas 23 y 24.

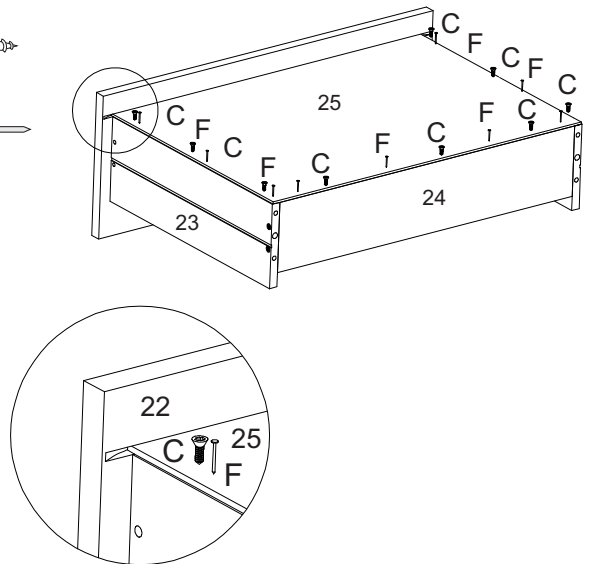

28° PASSO - Fixar o acessório C + J na peça 23.

28° STEP - Fix accessory C + J to part 23.

28° PASO - Fijar el accesorio C + J a la pieza 23.

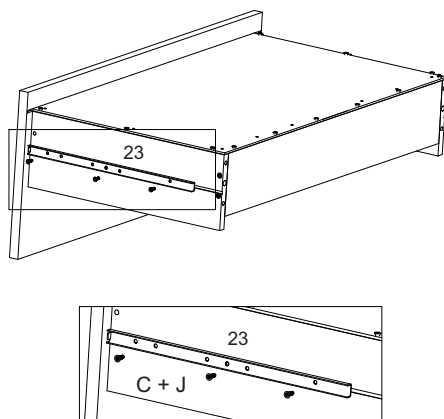

29° PASSO - Encaixe as gavetas

29° STEP - Fit the drawers

29° PASO - Encajar los cajones

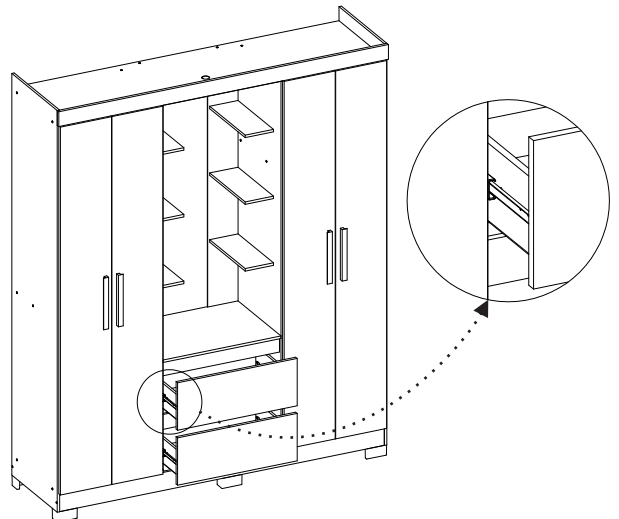

Aspecto final do produto

Final appearance of the product

Aspecto final del producto.

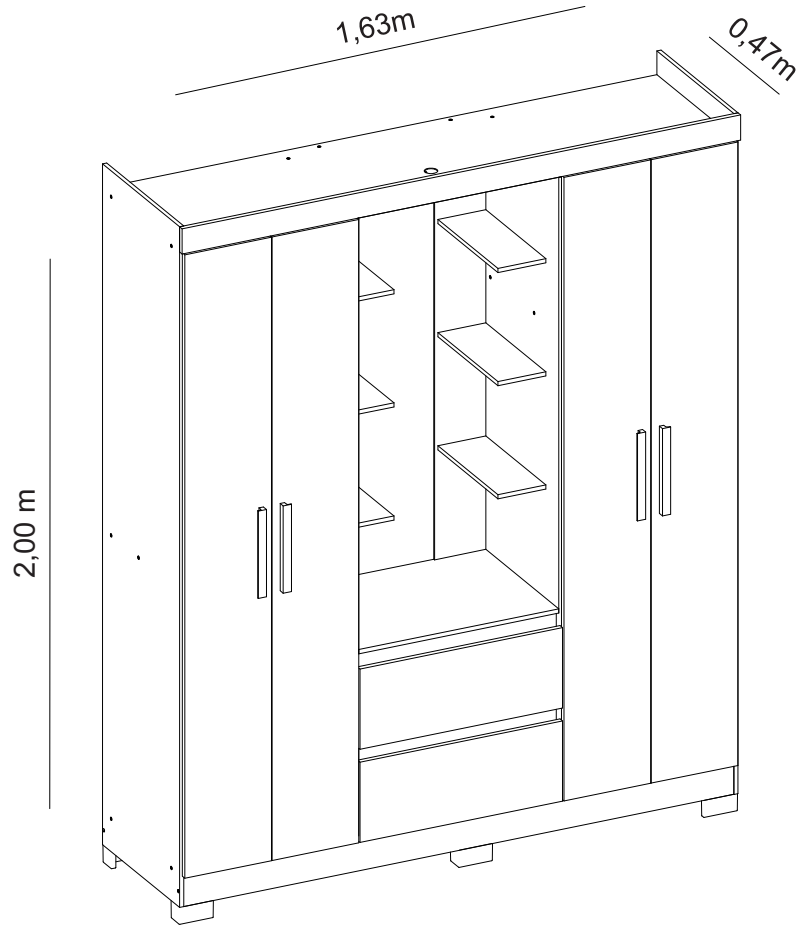

Agora que você já comprou o seu móvel, ele merece ser montado do jeito certo.

Erros de montagem causam mais de **60%** dos danos em móveis.

Por que contratar?

Tranquilidade do **início ao fim** da montagem



PROFISSIONAIS QUALIFICADOS

Especialistas certificados na **MadeiraMadeira Serviços**.



FERRAMENTAS PROFISSIONAIS

que **protegem** seus móveis.



AGENDAMENTO EM 24 HORAS

escolha a data e o turno **ideais para** você.



GARANTIA DE 3 MESES

de cobertura **completa**.

Mais de 1 MILHÃO DE MONTAGENS
★ com avaliação 4.7 ★

Mariana S., São Paulo

"Chegaram no horário e montaram tudo rapidamente. Serviço incrível!"



Carlos R., Belo Horizonte

"Tentei montar sozinho e foi um desastre. Com a **MadeiraMadeira Serviços** ficou perfeito."



Ana P., Rio de Janeiro

"Agendamento ágil e **montagem pontual e perfeita**. Recomendo demais!"



Agende agora pelo
QR Code

Madeira**Madeira** Serviços · Atendimento em todo o Brasil



Escaneie o QRCode