

HOME NT1335
HOME NT1335
NT1335 HOME

VOLUME | VOLUMEN | VOLUME: 02
CAPACIDADE TV | CAPACIDAD TV | TV SIZE: 65"

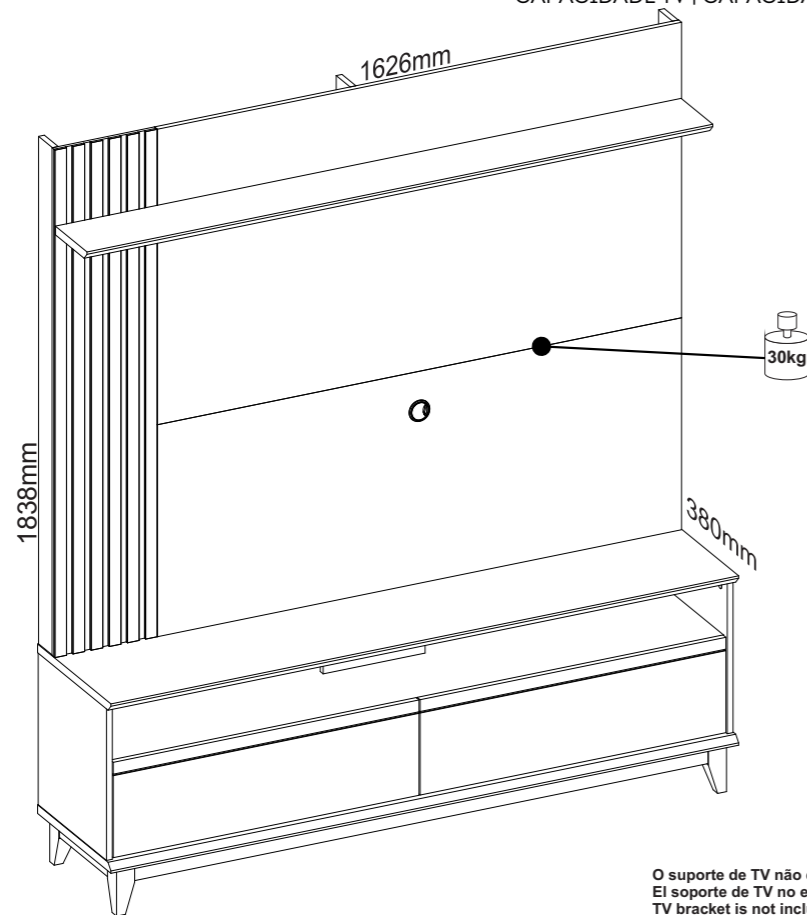

O suporte de TV não está incluído no produto.
El soporte de TV no está incluído en el producto.
TV bracket is not included

NOTÁVEL
móveis

INSTRUÇÕES:
INSTRUCTIONS:
INSTRUCCIONES:

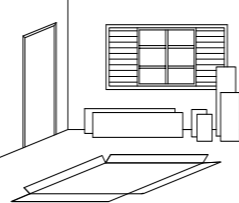

Separe as peças e acessórios de maneira organizada, em seguida forre o chão com o papelão das embalagens.

Separa las prendas y los accesorios deorganizados y, a continuaciónforre el suelo con cartón deembalaje.

Separate the garments and accessories in anorganized, thenline the floor with the cardboard from thepackaging.

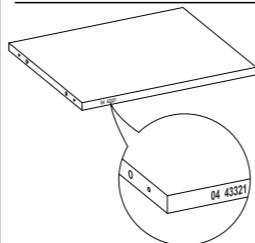

A marcação do número de lote e código da peça que aparece nas fitas de bordas é facilmente removida com pano umedecido no álcool.

El marcado del número de lote y código de pieza que aparece en else elimina fácilmente con un pañocon un paño humedecido en alcohol.

The marking of the batch number and part code that appears on this easily removedwith a cloth dampened in alcohol.

FERRAMENTAS NECESSÁRIAS (NÃO INCLUIDAS)
HERRAMIENTAS NECESARIAS (NO INCLUIDO)
TOOLS NEEDED (NOT INCLUDED)

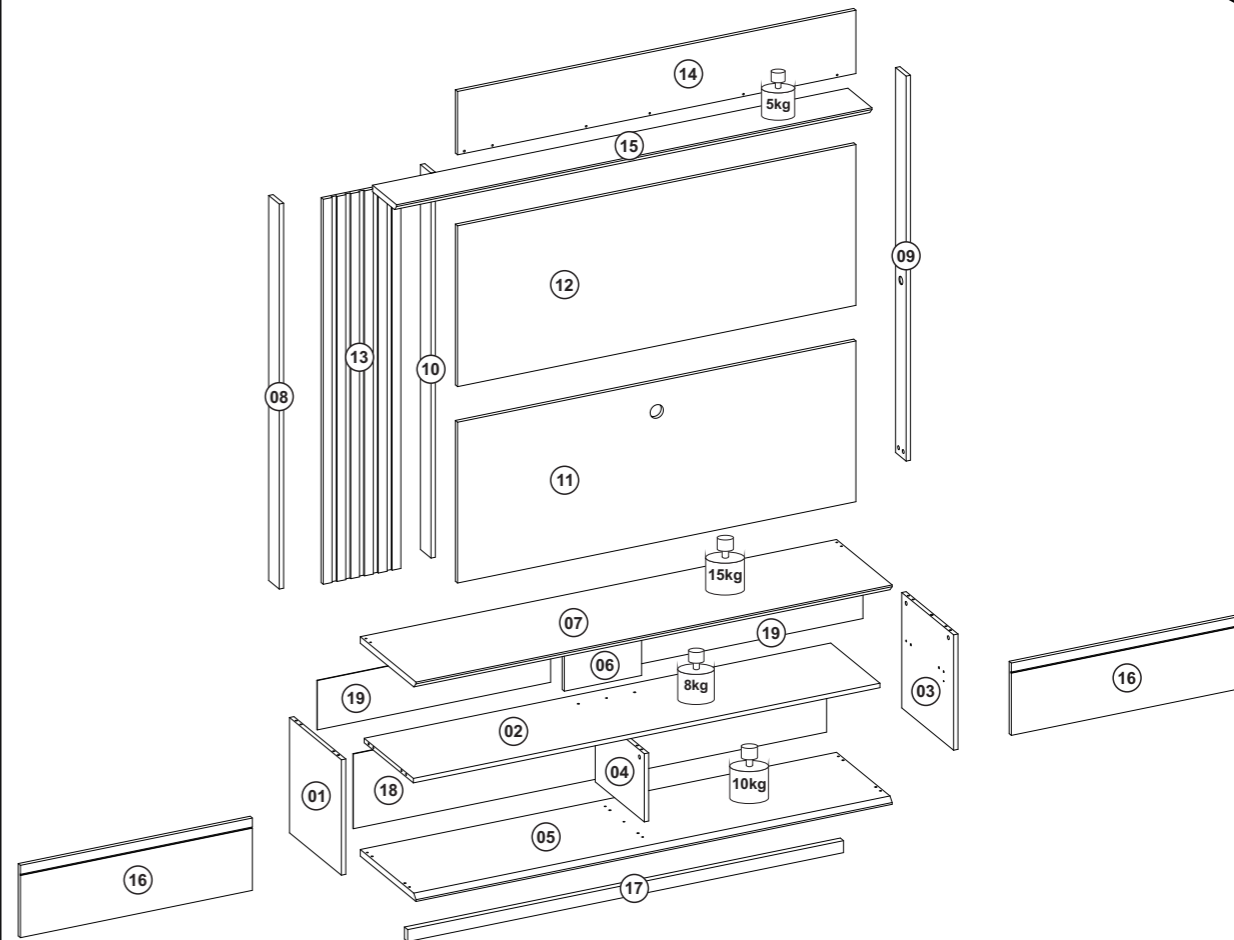
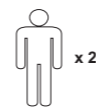

TERMO DE GARANTIA | TÉRMINO DE GARANTIA | WARRANTY TERM

Sr. Montador, favor conferir as peças antes da montagem, pois só efetuamos a troca do produto antes de ser montado. Garantimos este produto contra eventuais defeitos de fabricação por um período de (90) dias, conforme prevista no artigo 26 do Código do Consumidor a contar a partir da entrega do produto comprovado pela nota fiscal. Constatado o defeito de fabricação o consumidor(a) deverá solicitar assistência técnica através do estabelecimento da compra tendo em mãos a etiqueta do produto com o número do lote. Este termo de garantia será anulado e sem efeito na ocorrência das seguintes hipóteses:
- O peso suportado por cada prateleira deverá obedecer os valores indicados na ilustração;
- Não forem cumpridas as recomendações de montagem contidas neste manual;
- O defeito apresentado for causado pelo proprietário ou terceiros;
- Armazenamento do móvel em locais impróprios;
- Todo e qualquer recorte ou alteração no móvel;
- Manuseio e transporte do móvel de maneira inadequada.

Señor ensamblador, favor conferir las piezas antes del montaje, pues sólo cambiamos los productos antes de ensamblados. Esta garantía se ejerce dentro del periodo en el presente documento, con la presentación de este certificado y la factura. Si se detecta un defecto de fabricación, el consumidor debe solicitar asistencia técnica en el lugar de compra con la etiqueta del producto y el número de lote. Esta garantía quedará anulada y sin efecto en los siguientes casos:
- El peso soportado por cada balda debe respetar los valores indicados en la ilustración;
- No se siguen las recomendaciones de montaje contenidas en este manual;
- El defecto es causado por el propietario o por terceros;
- El almacenamiento del mueble en lugares inadecuados
- Cualquier corte o alteración en el mueble - Manipulación y transporte inadecuados del mueble.

Mr. Assembler, please check parts before assembling. We only replace products before put together. This warranty shall be applied within the time limits specified herein, by presentation of this certificate and invoice. If a manufacturing defect is found, the consumer must request technical assistance from the place of purchase, holding the product label with the batch number. This warranty will be null and void in the following cases:
- The weight supported by each shelf must comply with the values shown in the illustration;
- The assembly recommendations contained in this manual are not complied with;
- The defect is caused by the owner or third parties;
- Storage of the furniture in inappropriate places;
- Any cutting or alterations to the furniture;
- Improper handling and transportation of the furniture.

ACESSÓRIOS EM TAMANHO REAL | ACCESORIOS DE TAMAÑO NATURAL | LIFE-SIZE ACCESSORIES

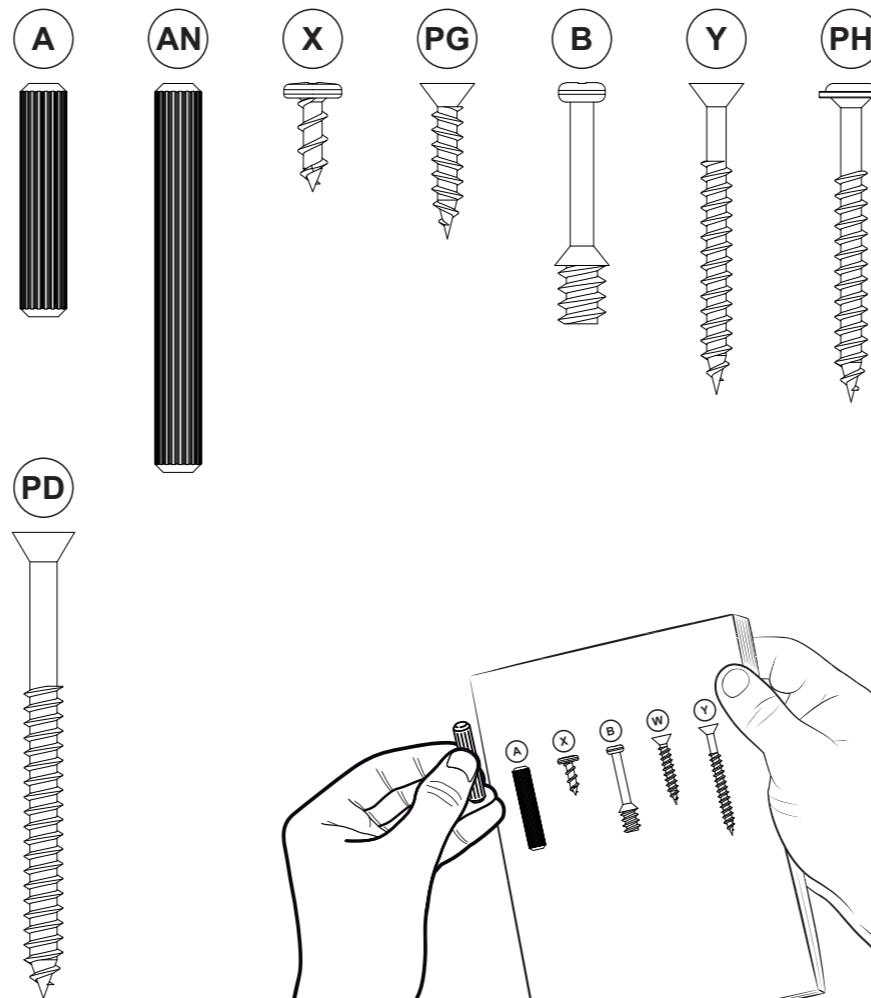

RELAÇÃO DE PEÇAS | LISTA DE PIEZAS | PARTS LIST

Nº PEÇA NR. PIEZA ITEM	DESCRIÇÃO DESCRIPCIÓN DESCRIPTION	MATERIAL	COD PEÇA COD PIEZA PART CODE	QTDE CTD. QTY.	COMP. LARGO LENGTH	LARG ANCHO WIDTH	ESP ESP THICK
1	LATERAL ESQUERDA LATERAL IZQUIERDA LEFT SIDE	MDP	70085-01	1	386	354	15
2	PRATELEIRA REPISA SHELF	MDP	70086-02	1	1593	336	15
3	LATERAL DIREITA LATERAL DERECHA RIGHT SIDE	MDP	70087-03	1	386	354	15
4	DIVISORIA DIVISION DIVISORY	MDP	70088-04	1	228	335	15
5	BASE INFERIOR BASE INFERIOR LOWER BASE	MDP	70089-05	1	1626	380	22
6	DIVISORIA DIVISION DIVISORY	MDP	70090-06	1	264	143	15
7	TAMPO CUBIERTA TOP	MDP	70091-07	1	1626	380	22
8	SUPORTE PAINEL PANEL SOPORTE PANEL SUPPORT	MDP	70092-08	1	1288	72	15
9	SUPORTE PAINEL PANEL SOPORTE PANEL SUPPORT	MDP	70093-09	1	1288	72	15
10	SUPORTE PAINEL PANEL SOPORTE PANEL SUPPORT	MDP	70094-10	1	1288	72	15
11	PAINEL INFERIOR PANEL INFERIOR LOWER PANNEL	MDP	70095-11	1	1358	538	15
12	PAINEL CENTRAL PANEL CENTRAL CENTER PANEL	MDP	70096-12	1	1358	538	15
13	PAINEL ESQUERDO PANEL IZQUIERDO LEFT PANEL	MDP	70097-13	1	1288	265	15
14	PAINEL SUPERIOR PANEL SUPERIOR UPPER PANNEL	MDP	70098-14	1	1358	212	15
15	PRATELEIRA REPISA SHELF	MDP	70099-15	1	1621	164	22
16	PORTA PUERTA DOOR	MDF	70100-16	2	792	242	15
17	RODAPÉ RODAPIÉ REAR SKIRTING BOARD	MDP	70180-17	1	1486	40	22
18	FUNDO FONDO BOTTOM	HDF	70101-18	1	1616	250	3
19	FUNDO FONDO BOTTOM	HDF	70102-19	2	793	171	3
20	KIT ACESSÓRIO KIT ACCESORIOS ACCESSORIES SET	-	70133-20	-	-	-	-

Caso tenha dificuldade na montagem aponte a câmera do seu celular no QR Code abaixo e acesse o manual virtual.

Si tienes problemas para montarlo, apunta la cámara de tu móvil al código QR que aparece a continuación y accede al manual virtual.

If you're having trouble assembling it, point your cell phone camera at the QR Code below and access the virtual manual.



CONSERVAÇÃO E LIMPEZA | CUIDADO Y LIMPIEZA | UPKEEP AND CLEANING



Não utilize produtos abrasivos como álcool e detergentes, como também esponjas rígidas ou palhas de aço na limpeza dos móveis.
Do not use abrasives such as alcohol and detergent, taugh soaker also steel wool to clean the furniture.
No use limpiadores abrasivos como alcohol y detergentes, así como esponjas rígidas o lana de acero para limpiar los muebles.



Proteja a superfície do móvel de objetos que transmitam calor ou umidade.
Protect the surface of the furniture against objects that can pass heat and humidity.
Proteja la superficie del mueble de objetos que transmitan calor o humedad.



Evitar o contato de água e produto de limpeza com o rodapé do produto, pois poderá danificá-lo.
Avoid the contact of water and cleaning products with baseboard, cause it should damage your product.
Evitar el contacto con agua y producto de limpieza con el rodapié del producto, pues poderá dañarlo.



Procure sempre utilizar flanela limpa e seca para limpeza.
Try always to use a clean and dry flannel to cleaning.
Busque siempre utilizar franela limpia y seca para la limpieza.

Data de atualização: 24/02/2024

RELAÇÃO DE FERRAGENS | LISTA DE HARDWARE | LIST OF HARDWARE

A 22 6,0x30mm CAVILHA MADEIRA CLAVIJA MADERA WOODEN DOWEL CÓDIGO:270 CODIGO:270 CODE:270	AN 06 6,0x50mm CAVILHA MADEIRA CLAVIJA MADERA WOODEN DOWEL CÓDIGO:1498 CODIGO:1498 CODE:1498	PG 08 3,5x20mm PARAFUSO CABEÇA CHATA TORNILLO CABEZA PLANA FLAT HEAD SCREW CÓDIGO:1 CODIGO:1 CODE:1	Y 07 3,5x40mm PARAFUSO CABEÇA CHATA TORNILLO CABEZA PLANA FLAT HEAD SCREW CÓDIGO:4 CODIGO:4 CODE:4	PH 05 3,5x40mm PARAFUSO CABEÇA FLANGEADA TORNILLO DE CABEÇA EMBRIDADA FLANGED HEAD SCREW CÓDIGO:1572 CODIGO:1572 CODE:1572	X 172 4,0x12mm PARAFUSO CABEÇA PANELA TORNILLO CABEZA SARTÉN PAN HEAD SCREW CÓDIGO:13 CODIGO:13 CODE:13
PD 07 4,5x60mm PARAFUSO CABEÇA CHATA TORNILLO CABEZA PLANA FLAT HEAD SCREW CÓDIGO:11 CODIGO:11 CODE:11	B 14 5,0x31mm PARAFUSO MINIFIX TORNILLO MINIFIX MINI-FIX SCREW CÓDIGO:324 CODIGO:324 CODE:324	C 14 TAMBOR MINIFIX BARRIL MINIFIX MINI-FIX BARREL CÓDIGO:286 CODIGO:286 CODE:286	R 06 TAPA FURO ADESIVO BOLSILLO ADHESIVO ADHESIVE HOLE POCKET CÓDIGO:119 CODIGO:119 CODE:119	D 67 2,0x24mm PREGO CLAVO NAIL CÓDIGO:268 CODIGO:268 CODE:268	E 10 FIXADOR DE FUNDO FIJADOR DE FONDO BOTTOM FIXER CÓDIGO:44 CODIGO:44 CODE:44
L 05 SAPATA PLÁSTICA ZAPATO DE PLÁSTICO PLASTIC SHOE CÓDIGO:250 CODIGO:250 CODE:250	PS 01 PASSA FIO PASE DE CABLES THREAD GUIDE CÓDIGO:1098 CODIGO:1098 CODE:1098	TT 26 CANTONEIRA 4 FUROS SOPORTE ANGULAR DE 4 ORIFICIOS 4 HOLE ANGLE BRACKET CÓDIGO:45 CODIGO:45 CODE:45	CM 08 CANTONEIRA 2 FUROS SOPORTE ANGULAR DE 2 ORIFICIOS 2 HOLE ANGLE BRACKET CÓDIGO:2014 CODIGO:2014 CODE:2014	TM 11 SUPORTE DE FIXAÇÃO SOPORTE DE FIJACIÓN FIXING BRACKET CÓDIGO:1537 CODIGO:1537 CODE:1537	M 04 DOBRADIÇA SUPER CURVA BISAGRA SUPER CURVADA SUPER CURVED HINGE CÓDIGO:280 CODIGO:280 CODE:280
Z 02 PISTÃO A GÁS PISTON DE GAS GAS PISTON CÓDIGO:276 CODIGO:276 CODE:276	PE 04 PÉ DE MADEIRA PIE DE MADERA WOODEN FOOT CÓDIGO:2736 CODIGO:2736 CODE:2736	PE 01 PÉ DE MADEIRA PIE DE MADERA WOODEN FOOT CÓDIGO:2737 CODIGO:2737 CODE:2737	RO 02 RODAPÉ RODAPIÉ SKIRTING BOARD CÓDIGO:2741 CODIGO:2741 CODE:2741	RO 01 RODAPÉ RODAPIÉ SKIRTING BOARD CÓDIGO:2742 CODIGO:2742 CODE:2742	

MONTAGEM | MONTAJE | ASSEMBLY

<p>PASSO 01 PASO 01 STEP 01</p> <p>1 - Insira as cavilhas [A] nas peças 1, 2, 3, 4, 6 e 15. 1 - Introduzca los tacos [A] en las partes 1, 2, 3, 4, 6 y 15. 1 - Insert the dowels [A] into parts 1, 2, 3, 4, 6 and 15.</p>	<p>PASSO 03 PASO 03 STEP 03</p> <p>1 - Encaixe as peças 1 e 3 na peça 2. Encaixe os tambores minifix [C] na peça 2 e gire até travar. 1 - Monte las piezas 1 y 3 en la pieza 2. Monte los tambores minifix [C] en la pieza 2 y gírelos hasta que encajen. 1 - Fit parts 1 and 3 onto part 2. Insert the minifix drums [C] into part 2 and turn until they lock.</p>	<p>PASSO 05 PASO 05 STEP 05</p> <p>1 - Encaixe a peça 4 na peça 2. Encaixe os tambores minifix [C] na peça 4 e gire até travar. 2 - Cole os adesivos [R] sobre os tambores [C]. 1 - Montar la pieza 4 en la pieza 2. Monte los tambores minifix [C] en la pieza 4 y gírelos hasta que encajen. 2 - Pega las pegatinas [R] en los tambores [C]. 1 - Fit part 4 onto part 2. Insert the minifix drums [C] into part 4 and turn until they lock. 2 - Stick the stickers [R] onto the drums [C].</p>
<p>PASSO 02 PASO 02 STEP 02</p> <p>1 - Fixe os minifix [B] nas peças 1, 2, 3 e 7. 1 - Fije los minifijos [B] a las piezas 1, 2, 3 y 7. 1 - Attach the minifixes [B] to parts 1, 2, 3 and 7.</p>	<p>PASSO 04 PASO 04 STEP 04</p> <p>1 - Encaixe a peça 6 na peça 2 e fixe as com o parafuso [Y]. 1 - Coloque la pieza 6 en la pieza 2 y fijela con el tornillo [Y]. 1 - Fit part 6 to part 2 and secure with screw [Y].</p>	<p>PASSO 06 PASO 06 STEP 06</p> <p>1 - Alinhe o pé [PE] no furo central da peça 5 e fixe-o com o parafusos [PD]... 2 - Fixe a sapata [L] com o prego [D] no pé [PE]. 1 - Alinee el pie [PE] en el orificio central de la pieza 5 y fijelo con los tornillos [PD]. 2 - Fije el zapato [L] con el clavo [D] al pie [PE]. 1 - Align the foot [PE] in the central hole of part 5 and secure it with the screws [PD]. 2 - Attach the shoe [L] with the nail [D] to the foot [PE].</p>

PASSO 07 1 - Encaixe a peça 5 nas peças 1, 3 e 4, fixe as com os parafusos [Y].

PASO 07 1 - Montar la pieza 5 en las piezas 1, 3 y 4, fijarla con tornillos [Y].

STEP 07 1 - Fit part 5 to parts 1, 3 and 4, secure with screws [Y].

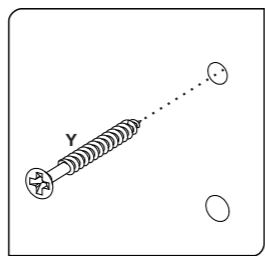
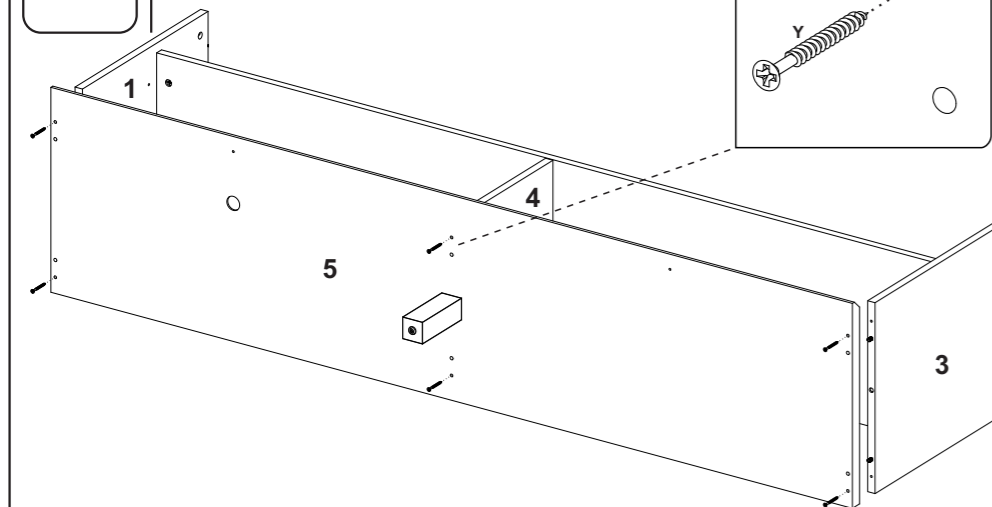
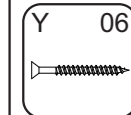

PASSO 10 1 - Alinhe o conjunto montado no passo anterior nas marcações da peça 5 e fixe-o com os parafusos [PH].

PASO 10 2 - Fije a peça 17 na peça 5 com as cantoneiras [TT] e os parafusos [X].

STEP 10 1 - Alinee el conjunto montado en el paso anterior con las marcas de la pieza 5 y fijelo con los tornillos [PH].

2 - Fije la pieza 17 a la pieza 5 con las escuadras [TT] y los tornillos [X].

1 - Align the assembly fitted in the previous step with the markings on part 5 and secure it with the screws [PH].

2 - Attach part 17 to part 5 with the angle brackets [TT] and screws [X].

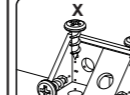
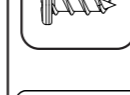
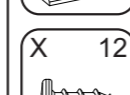

1 - Encaixe a peça 7 nas peças 1, 3 e 6. Encaixe os tambores minifix [C] nas peças 1 e 3, gire até travar.

PASSO 11 1 - Encaje la pieza 7 en las piezas 1, 3 y 6. Encaje los tambores minifix [C] en las piezas 1 y 3, gírelos hasta que encajen.

PASO 11 1 - Fit part 7 onto parts 1, 3 and 6. Fit the minifix drums [C] into parts 1 and 3, turn until they lock.

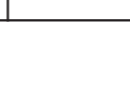
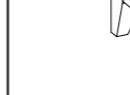
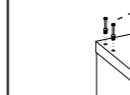
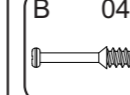
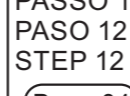
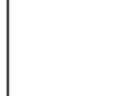

PASSO 13 1 - Encaixe as peças 8 e 9 na peça 7. Encaixe os tambores minifix [C] nas peças 8 e 9, gire até travar.

PASO 13 1 - Encaje las piezas 8 y 9 en la pieza 7. Monte los tambores minifix [C] en las piezas 8 y 9, gírelos hasta que encajen.

STEP 13 1 - Fit parts 8 and 9 into part 7. Fit the minifix drums [C] onto parts 8 and 9, turn until they lock.

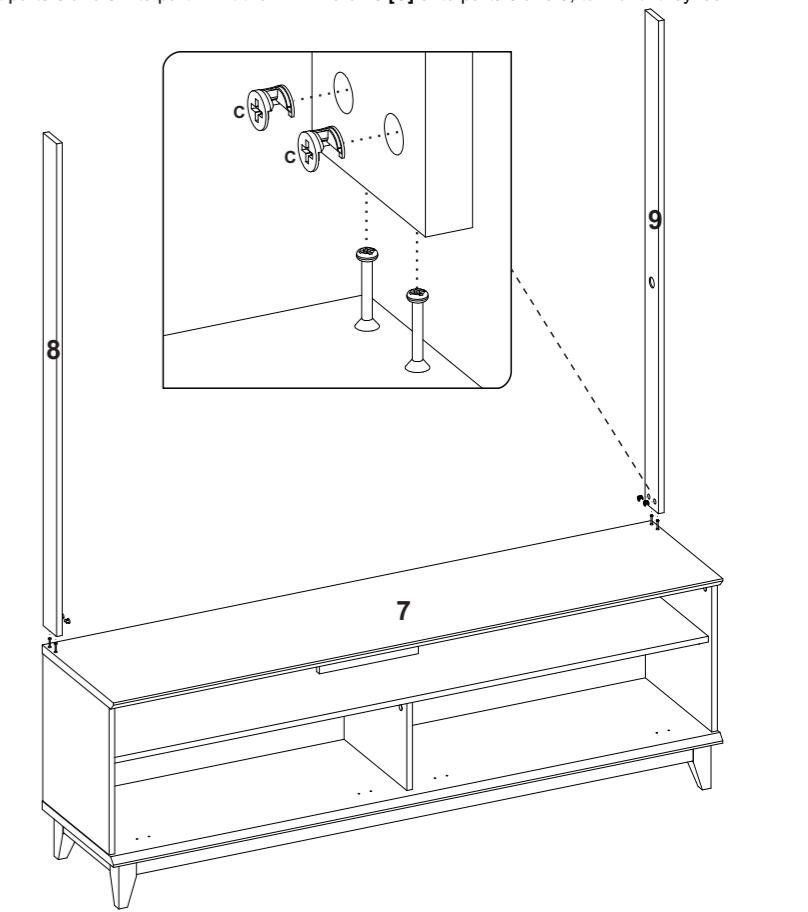
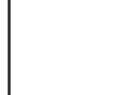
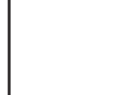
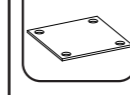
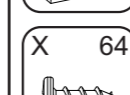
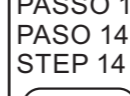
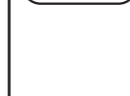
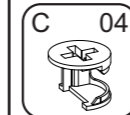

PASSO 08 1 - Insira as cavilhas [AN] nos rodapés [RO].

2 - Encaixe os pés [PE] nos rodapés [RO].

PASO 08 1 - Introduzca las espigas [AN] en los zócalos [RO].

2 - Introduzca las patas [PE] en los zócalos [RO].

STEP 08 1 - Insert the dowels [AN] into the plinths [RO].

2 - Insert the feet [PE] into the plinths [RO].

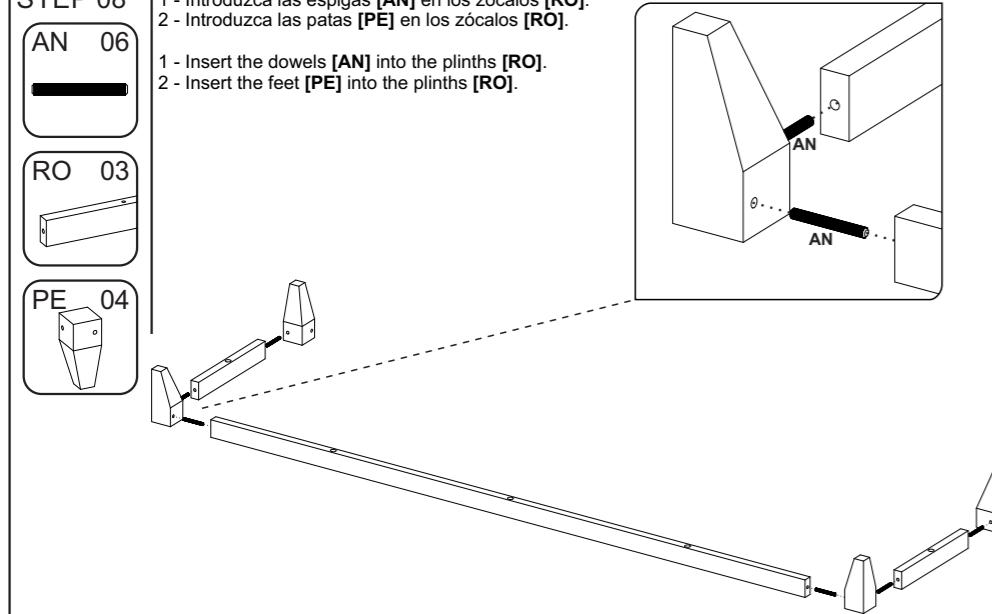
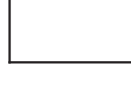
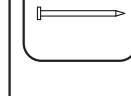
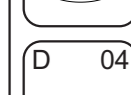
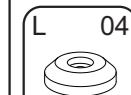
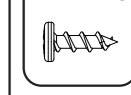
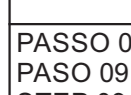
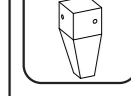
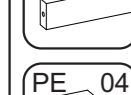

PASSO 09 1 - Alinhe a peça 17 no conjunto montado no passo anterior.

2 - Fixe todos os pés nos rodapés utilizando as cantoneiras [CM] com os parafusos [X].

3 - Fixe a sapata [L] com o prego [D] no pé [PE].

PASO 09 1 - Alinee la pieza 17 en el conjunto montado en el paso anterior.

2 - Fije todos los pies a los rodapiés utilizando las escuadras [CM] con los tornillos [X].

3 - Fije el zapato [L] con el clavo [D] al pie [PE].

STEP 09 1 - Align part 17 on the assembly set up in the previous step.

2 - Fix all the feet to the skirting boards using the angle brackets [CM] with the screws [X].

3 - Attach the shoe [L] with the nail [D] to the foot [PE].

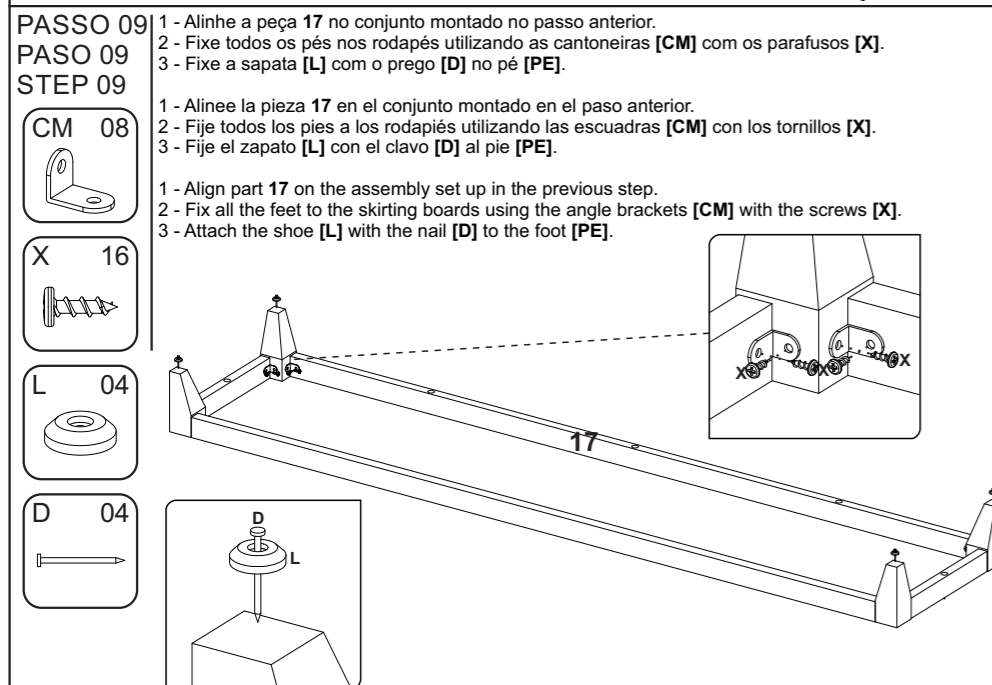
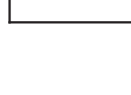
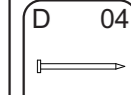
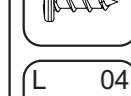

PASSO 12 1 - Fixe os minifix [B] na peça 7.

PASO 12 1 - Fije el minifix [B] a la pieza 7.

STEP 12 1 - Attach the minifixes [B] to part 7.

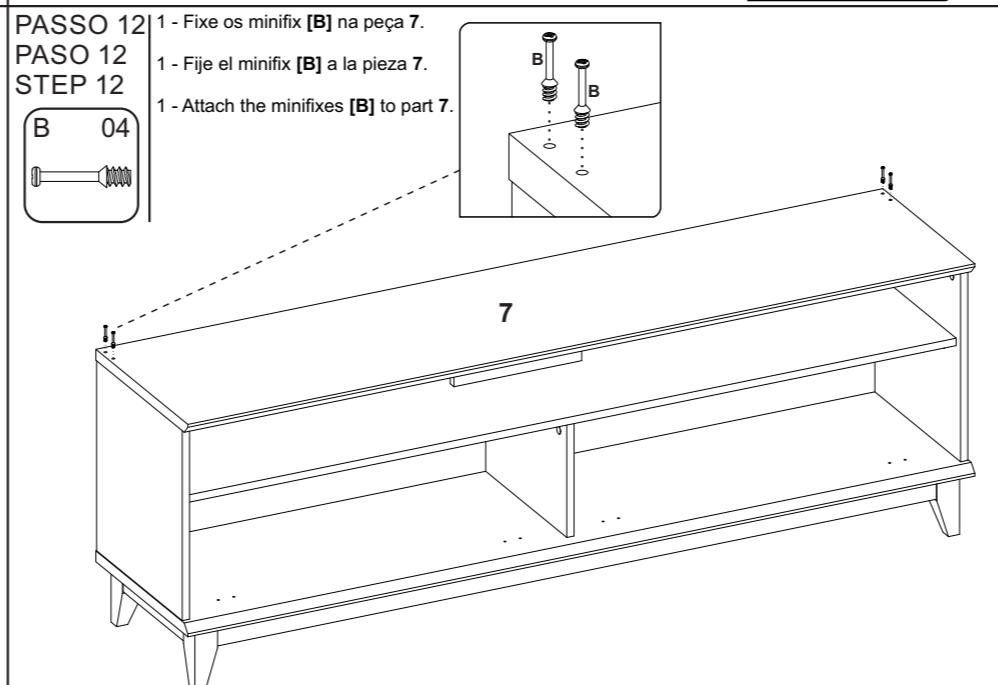
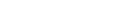
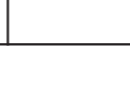
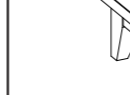
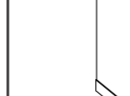
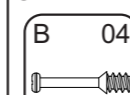

PASSO 14 1 - Fixe as peças 8 e 9 na peça 7 com as cantoneiras [TT] e os parafusos [X].

2 - Alinhe as peças 11 e 13 como na imagem abaixo e fixe as nas peças 7, 8 e 9 com as cantoneiras [TT] e os parafusos [X].

3 - Fixe as peças 11 e 13 com os suportes [TM] e os parafusos [X].

PASO 14 1 - Fije las piezas 8 y 9 a la pieza 7 con las escuadras [TT] y los tornillos [X].

2 - Alinee las piezas 11 y 13 como en la imagen inferior y fijelas a las piezas 7, 8 y 9 con las escuadras [TT] y los tornillos [X].

3 - Fije las piezas 11 y 13 con las escuadras [TM] y los tornillos [X].

STEP 14 1 - Attach parts 8 and 9 to part 7 with the angle brackets [TT] and screws [X].

2 - Align parts 11 and 13 as in the image below and fix them to parts 7, 8 and 9 with the angle brackets [TT] and screws [X].

3 - Secure parts 11 and 13 with the brackets [TM] and screws [X].

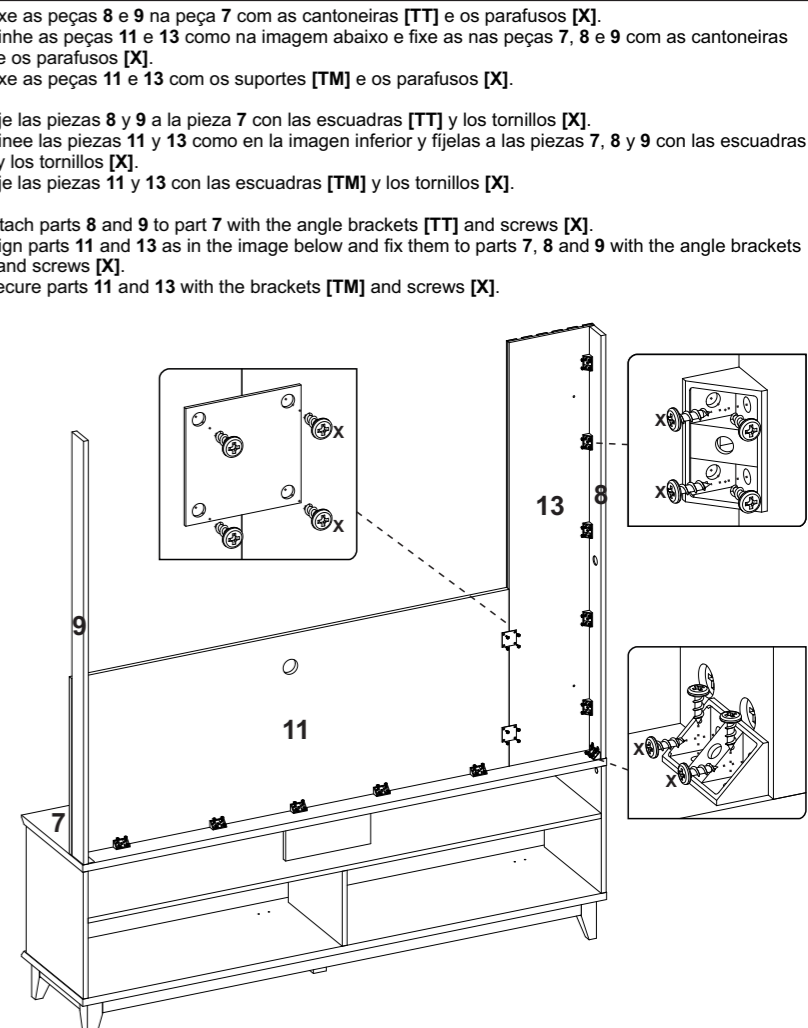
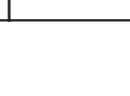
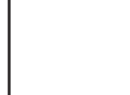
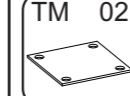
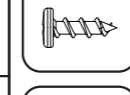

PASSO 15
PASO 15
STEP 15

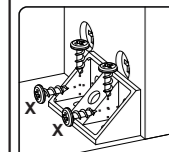
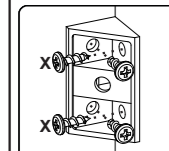
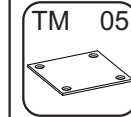
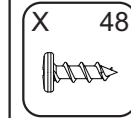
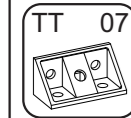

1 - Alinhe a peça 10 conforme a imagem abaixo e fixe a nas peças 7 e 11 com as cantoneiras [TT] e os parafusos [X].
 2 - Alinhe a peça 12 como na imagem abaixo e fixe a nas peças 9 e 10 com as cantoneiras [TT] e os parafusos [X].
 3 - Fixe as peças 11, 12 e 13 com os suportes [TM] e os parafusos [X].

1 - Alinee la pieza 10 como se muestra en la imagen inferior y fijela a las piezas 7 y 11 con las escuadras [TT] y los tornillos [X].
 2 - Alinee la pieza 12 como se muestra en la imagen inferior y fijela a las piezas 9 y 10 con las escuadras [TT] y los tornillos [X].
 3 - Fije las piezas 11, 12 y 13 con los soportes [TM] y los tornillos [X].

1 - Align part 10 as shown below and attach it to parts 7 and 11 with the [TT] angle brackets and [X] screws.
 2 - Align part 12 as shown in the image below and fix it to parts 9 and 10 with the angle brackets [TT] and screws [X].
 3 - Secure parts 11, 12 and 13 with the brackets [TM] and screws [X].

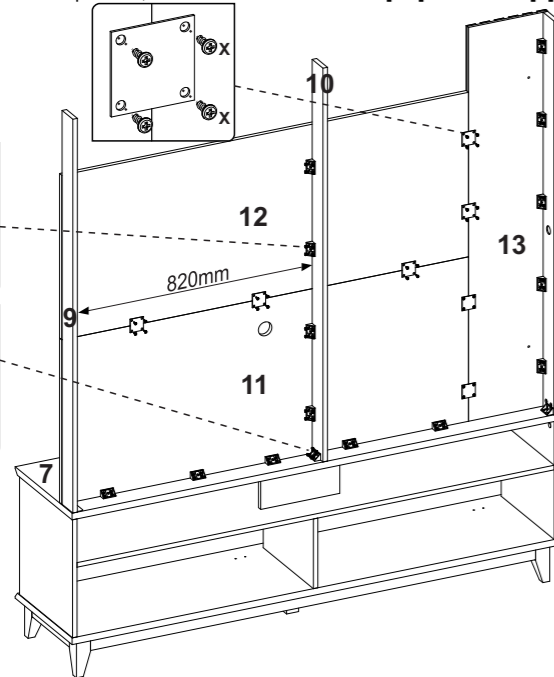

PASSO 17
PASO 17
STEP 17

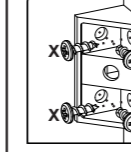
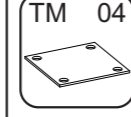
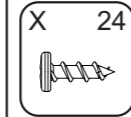
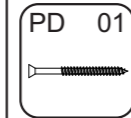

1 - Alinhe o conjunto montado no passo anterior conforme a imagem abaixo. Em seguida fixe a peça 14 nas peças 9 e 10 com as cantoneiras [TT] e os parafusos [X].
 2 - Fixe as peças 12, 13 e 14 com os suportes [TM] e os parafusos [X].
 3 - Fixe a peça 13 na peça 15 com o parafuso [PD].

1 - Alinee el conjunto montado en el paso anterior como se muestra en la imagen inferior. A continuación, fije la pieza 14 a las piezas 9 y 10 con las escuadras [TT] y los tornillos [X].
 2 - Fije las piezas 12, 13 y 14 con las escuadras [TM] y los tornillos [X].
 3 - Fije la pieza 13 a la pieza 15 con el tornillo [PD].

1 - Align the set assembled in the previous step as shown in the image below. Then attach part 14 to parts 9 and 10 with the angle brackets [TT] and screws [X].
 2 - Attach parts 12, 13 and 14 with the brackets [TM] and screws [X].
 3 - Secure part 13 to part 15 with screw [PD].

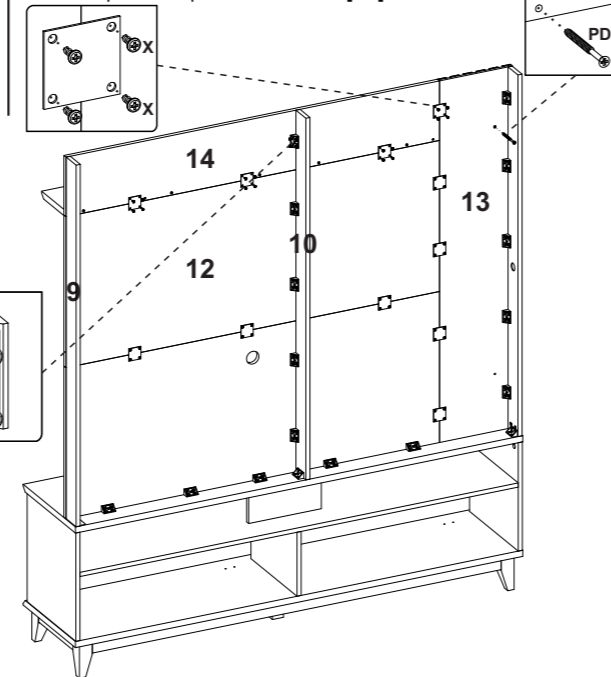

PASSO 19
PASO 19
STEP 19

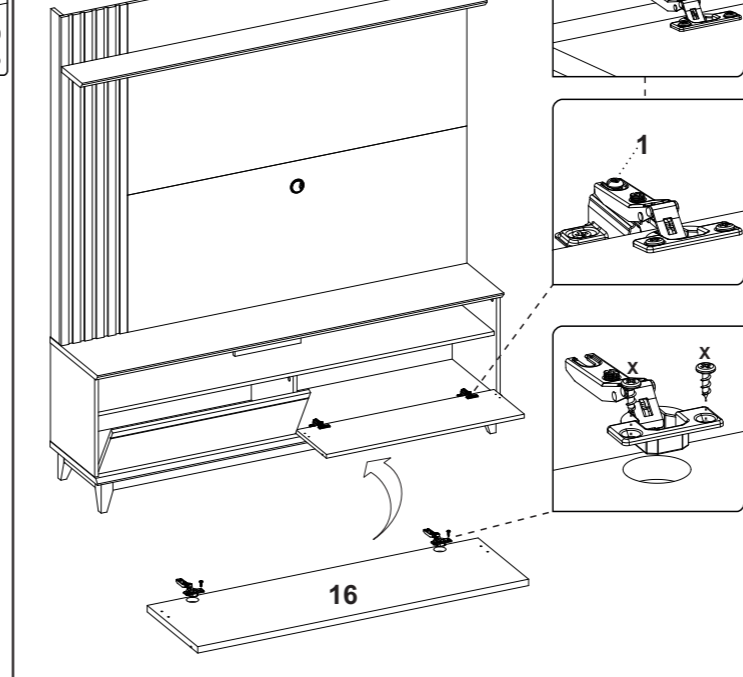
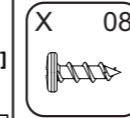
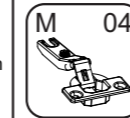

1 - Encaixe as dobradiças [M] na peça 16 e fixe as com os parafusos [X].
 2 - Para montar a porta, encaixe as dobradiças nos calços travando-a no parafuso indicado com o número 1 abaixo.

1 - Monte las bisagras [M] en la pieza 16 y fijelas con los tornillos [X].
 2 - Para montar la puerta, encaje las bisagras en las cuñas, fijándolas en el tornillo indicado con el número 1 a continuación.

1 - Fit the hinges [M] onto part 16 and secure them with the screws [X].
 2 - To assemble the door, fit the hinges onto the wedges, locking it onto the screw indicated with the number 1 below.

PASSO 16
PASO 16
STEP 16

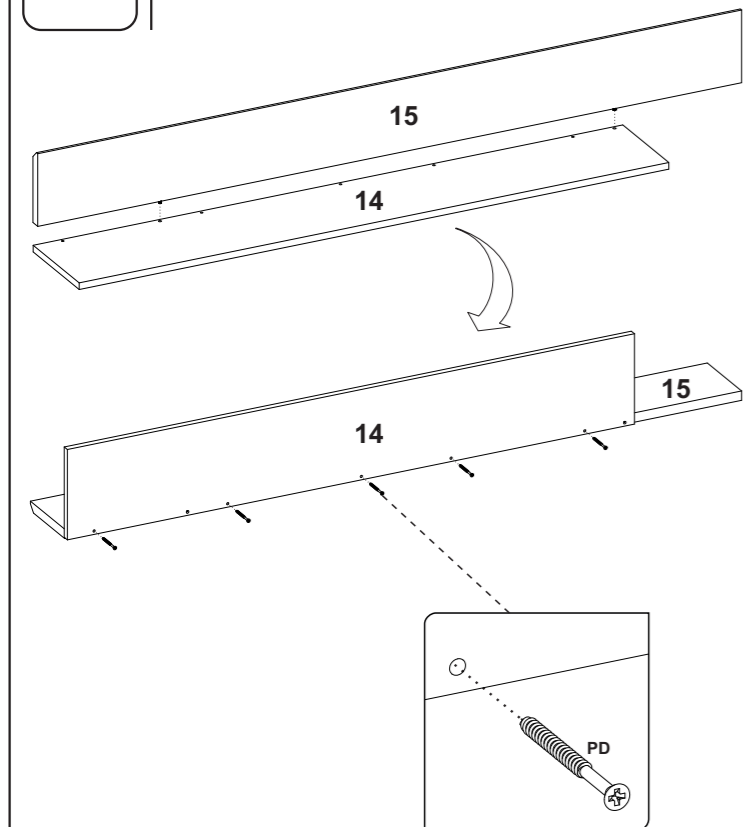
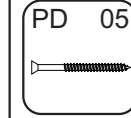

1 - Encaixe a peça 15 na peça 14 e fixe as com os parafusos [PD].

1 - Coloque la pieza 15 en la pieza 14 y fijela con los tornillos [PD].

1 - Fit part 15 to part 14 and secure with screws [PD].

PASSO 18
PASO 18
STEP 18

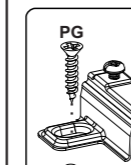
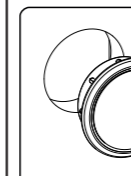
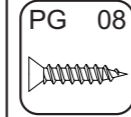
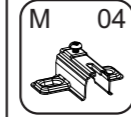
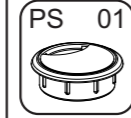

1 - Encaixe o passo fio [PS] na peça 11.
 2 - Alinhe os calços [M] nas marcações da peça 5 e fixe os com os parafusos [PG].

1 - Coloque el paso de cable [PS] en la pieza 11.
 2 - Alinee los calzos [M] con las marcas de la pieza 5 y fijelos con los tornillos [PG].

1 - Fit the wire step [PS] into part 11.
 2 - Align the shims [M] with the markings on part 5 and secure with the screws [PG].

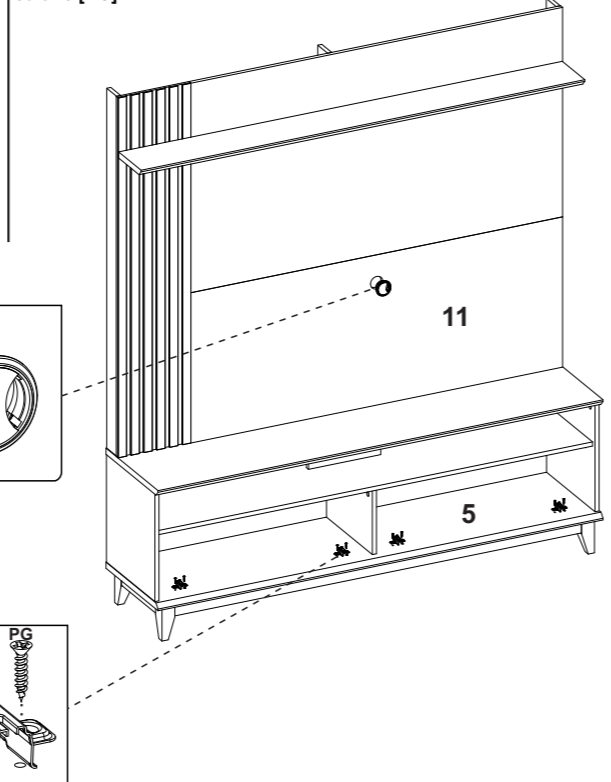

PASSO 20
PASO 20
STEP 20

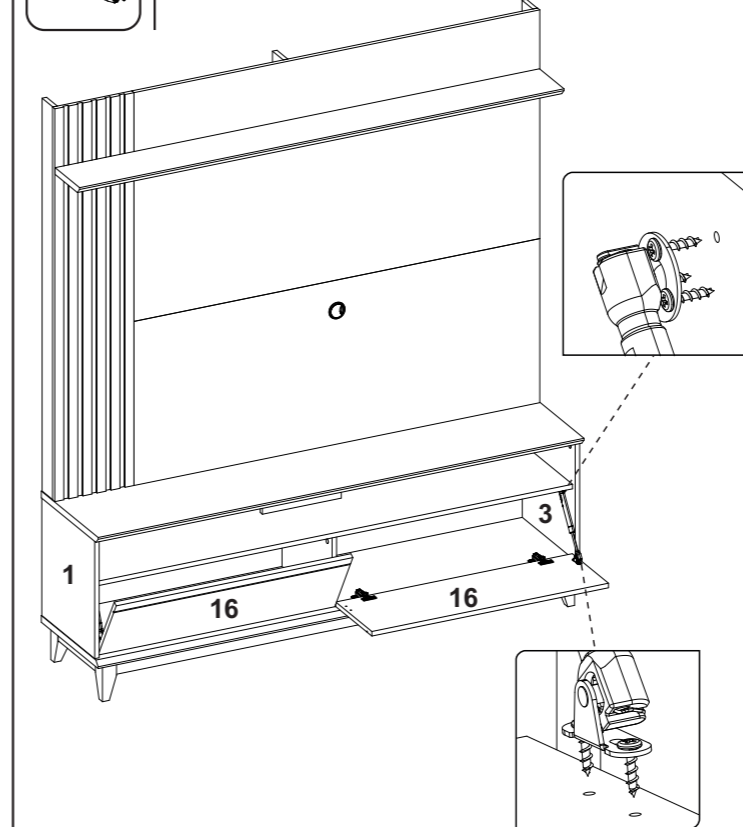
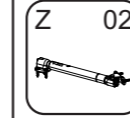

1 - Fixe o pistão [Z] nas marcações das peças 1, 3 e 16 como no desenho abaixo, utilize os parafusos que acompanham o pistão.

1 - Fije el pistón [Z] en las marcas de las piezas 1, 3 y 16 como en el dibujo abajo, utilizando los tornillos que vienen con el pistón.

1 - Attach the piston [Z] to the markings on parts 1, 3 and 16 as in the drawing below, using the screws that come with the piston.

PASSO 21
PASO 21
STEP 21

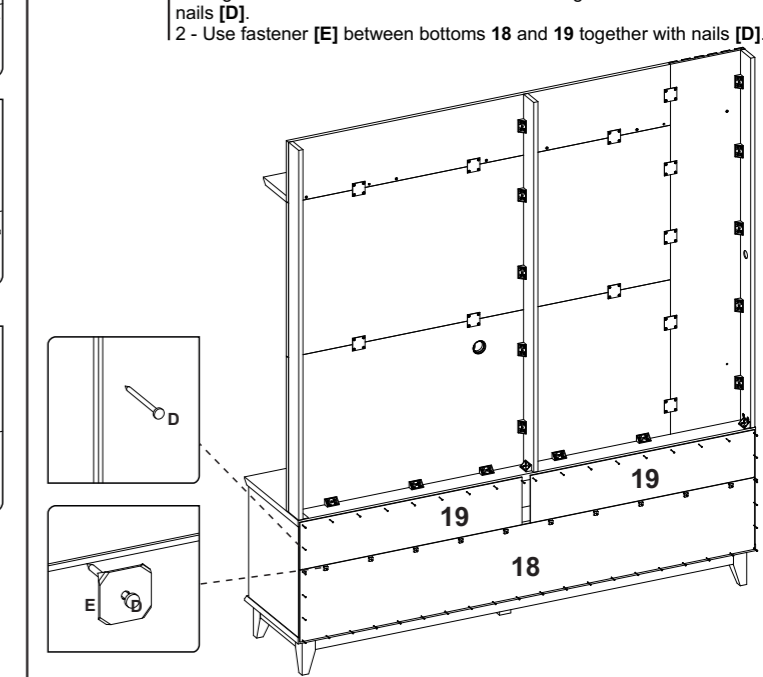
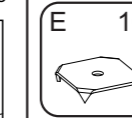
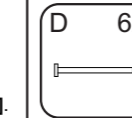

ATENÇÃO: Antes de fixar os fundos verifique o esquadro do produto.
 1 - Alinhe os fundos 18 e 19 como na imagem abaixo e fixe os com os pregos [D].
 2 - Entre os fundos 18 e 19 utilize fixador [E] em conjunto com os pregos [D].

ATENCIÓN: Antes de fijar los fondos, verifique que el producto esté a escuadra.
 1 - Alinee los fondos 18 y 19 como muestra la imagen inferior y fijelos con clavos [D].
 2 - Utilice el sujetador [E] entre los fondos 18 y 19 junto con los clavos [D].

ATTENTION: Before attaching the bottoms, check that the product is square.
 1 - Align bottoms 18 and 19 as shown in the image below and fix with nails [D].
 2 - Use fastener [E] between bottoms 18 and 19 together with nails [D].

Para a regulagem das portas siga as instruções conforme os números abaixo:

1 - Se precisar ajustar a porta para os lados desaperte um pouco os parafusos indicados como número 1, reposicione e aperte novamente.
 2 - Se precisar empurrar a porta mais pra dentro ou puxá-la para fora, desaperte um pouco o parafuso indicado com o número 2, reposicione e aperte novamente.
 3 - Se precisar alinhar a porta um pouco mais para o centro, utilize uma chave philips para girar o parafuso indicado com o número 3 até posicionar a porta da forma desejada.

Para ajustar las puertas, siga las instrucciones de los números siguientes:

1 - Si necesita ajustar la puerta lateralmente, afloje ligeramente los tornillos indicados como número 1, vuelva a colocar y apriete de nuevo.
 2 - Si necesita empujar la puerta hacia dentro o tirar de ella hacia fuera, afloje ligeramente el tornillo indicado como número 2, vuelva a colocar y apriete de nuevo.
 3 - Si necesita alinear la puerta un poco más hacia el centro, utilice un destornillador philips para girar el tornillo indicado con el número 3 hasta que la puerta quede posicionada de la forma deseada.

To adjust the doors, follow the instructions in the numbers below:

1 - If you need to adjust the door sideways, slightly loosen the screws indicated as number 1, reposition and tighten again.
 2 - If you need to push the door inwards or pull it outwards, slightly loosen the screw indicated with the number 2, reposition and tighten again.
 3 - If you need to align the door a little more towards the center, use a philips screwdriver to turn the screw indicated with the number 3 until the door is positioned the way you want.

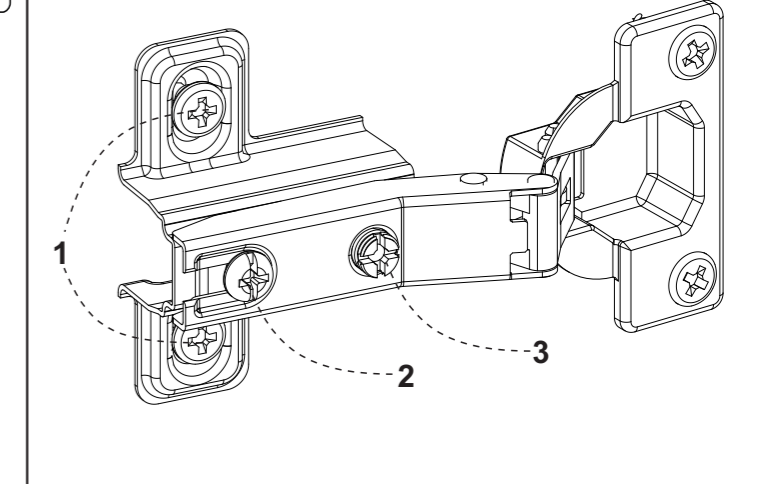

Agora que você já comprou o seu móvel, ele merece ser montado do jeito certo.

Erros de montagem causam mais de **60%** dos danos em móveis.

Por que contratar?

Tranquilidade do **início ao fim** da montagem



PROFISSIONAIS QUALIFICADOS

Especialistas certificados na **MadeiraMadeira Serviços**.



FERRAMENTAS PROFISSIONAIS

que **protegem** seus móveis.



AGENDAMENTO EM 24 HORAS

escolha a data e o turno **ideais para** você.



GARANTIA DE 3 MESES

de cobertura **completa**.

Mais de 1 MILHÃO DE MONTAGENS
★ com avaliação 4.7 ★

Mariana S., São Paulo

"Chegaram no horário e montaram tudo rapidamente. Serviço incrível!"



Carlos R., Belo Horizonte

"Tentei montar sozinho e foi um desastre. Com a **MadeiraMadeira Serviços** ficou perfeito."



Ana P., Rio de Janeiro

"Agendamento ágil e **montagem pontual e perfeita**. Recomendo demais!"



Agende agora pelo QR Code

Madeira**Madeira** Serviços · Atendimento em todo o Brasil



Escaneie o QRCode