

MANUAL DE MONTAGEM

ASSEMBLY INSTRUCTIONS

INSTRUCCIONES DE MONTAJE

NOTICE DE MONTAGE

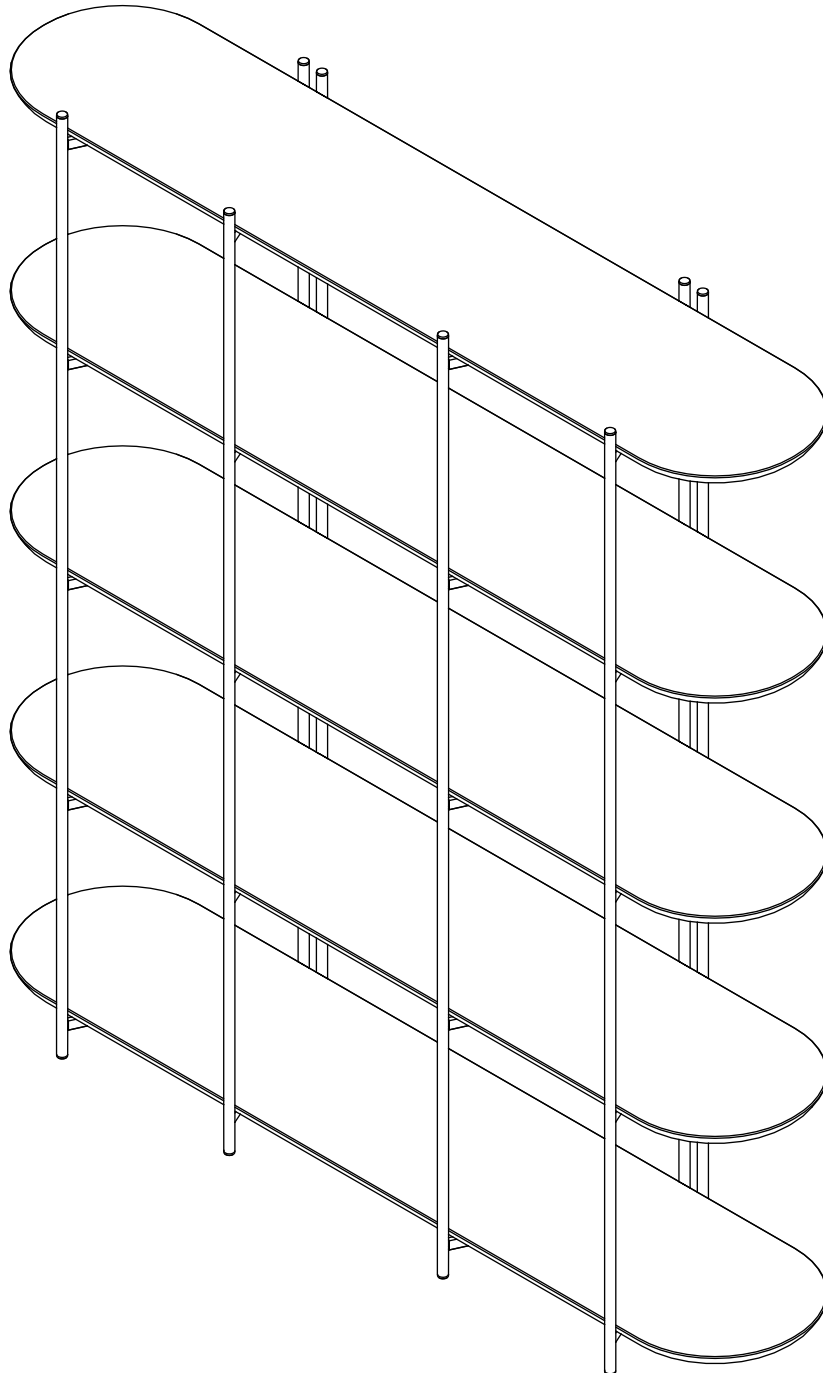

COD: 4100500

REV. 00 - 31/01/24

OBSERVAÇÕES IMPORTANTES IMPORTANT REMARKS OBSERVACIONES IMPORTANTES REMARQUES IMPORTANTES



Nunca escale ou se apoie sobre o móvel. Você pode sofrer graves acidentes.

Never climb or lean on the furniture. You may suffer serious accidents.

Nunca escale o apoye sobre el mobiliario. Usted puede sufrir graves accidentes.

Ne montez jamais sur le meuble. Vous pourriez subir un grave accident.

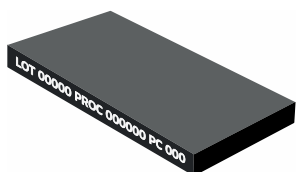

Observe os números impressos nas bordas para identificar as peças.

Identify the parts by observing the number printed on their edges.

Identifique las piezas observando el numero impreso en sus bordes.

Notez les numéros imprimés sur les bords pour identifier les pièces.



Movimente o móvel com cuidado, sem arrastar. Peça ajuda a outra pessoa para fazê-lo.

Move the piece carefully, don't drag it. Ask for someone else's help to do so.

Mover la unidad con cuidado, sin arrastar. Pedir ayuda da otra persona para moverlo.

Déplacez les meubles avec précaution sans le faire glisser. Demandez a quelqu'un de vous aider à le faire.

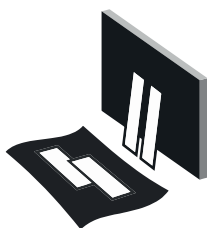

Utilize a embalagem para forrar a área de montagem e separar todas as peças.

Use the packaging to cover the assembly area and separate all parts.

Utilice el embalaje para cubrir la area de montaje y separe las piezas.

Couvrez la zone d'assemblage avec l'emballage pour séparer le pièces.



Limpe com um pano limpo e umedecido em água e sabão neutro. Não utilizar produtos químicos e abrasivos.

Wipe clean using a damp cloth and a mild cleaner. Don't use abrasive and chemical products.

Limpie con un paño limpiohumedecido con agua y jabón neutro. No utilice productos químicos y abrasivos.

Nettoyez avec un chiffon propre imbibé avec d'eau et de savon doux. N'utilisez pas de produits chimiques et abrasifs.



Não colocar objetos em alta temperatura diretamente sobre superfícies de vidro.

Do not place high-temperature objects directly on glass surfaces.

No coloque objetos de alta temperatura directamente sobre superficies de vidro.

Ne placez pas d'objets à haute température directment sur les surfaces en verre.

ACESSÓRIOS HARDWARE HERRAJES ACCESSOIRES

Identifique e separe os acessórios utilizados. Em cada embalagem, uma etiqueta identifica as peças e onde utilizá-las.

Identify and separate the hardware used in the assembly. There's a label on each package identifying the parts and where to use them.

Identifique y separe los accesorios utilizados en el montaje. Observe la etiqueta en cada paquete para saber donde montar.

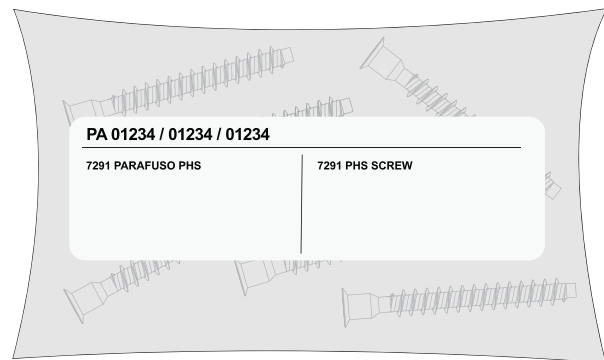

Identifiez et séparez les accessoires à être utilisés. Dans chaque emballage il y a une étiquette pour identifier les pièces et où les utiliser.

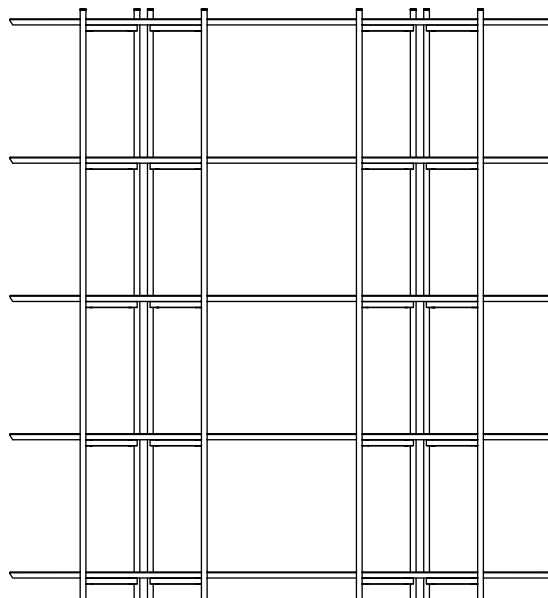

1800 mm

L:1800mm A:1958mm P:439mm
W:70.87in H:77.09in D:17.28in
L:1800mm A:1958mm P:439mm
L:1800mm H:1958mm P:439mm



A	B
COD. 13268	COD. 0714
(16X)	4.5 X 30
	(40X) 

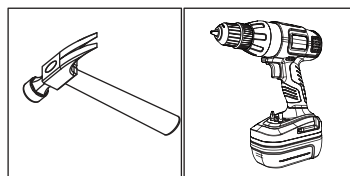

MONTAGEM NECESSITA 2 PESSOAS
 ASSEMBLY REQUIRES 2 PEOPLE
 EL MONTAJE NECESITA 2 PERSONAS
 MONTAGE A 2 PERSONNES

 An icon representing two stylized human figures standing side-by-side.

DESCRIÇÃO/ DESCRIPTION/ DESCRIPCIÓN/ DESCRIPTION

COD: 4100500

PEÇA PART PIEZA PIÈCE	QUANTIDADE QUANTITY CANTIDAD QUANTITÉ	DESCRIÇÃO	DESCRIPTION	DESCRIPCIÓN	DESCRIPTION	CAIXA BOX CAJA BOÎTE
01	05	TAMPO	TAMPO	TAMPO	TAMPO	01
161	04	BASE DE AÇO	STEEL BASE	BASE DE ACERO	BASE EN ACIER	01

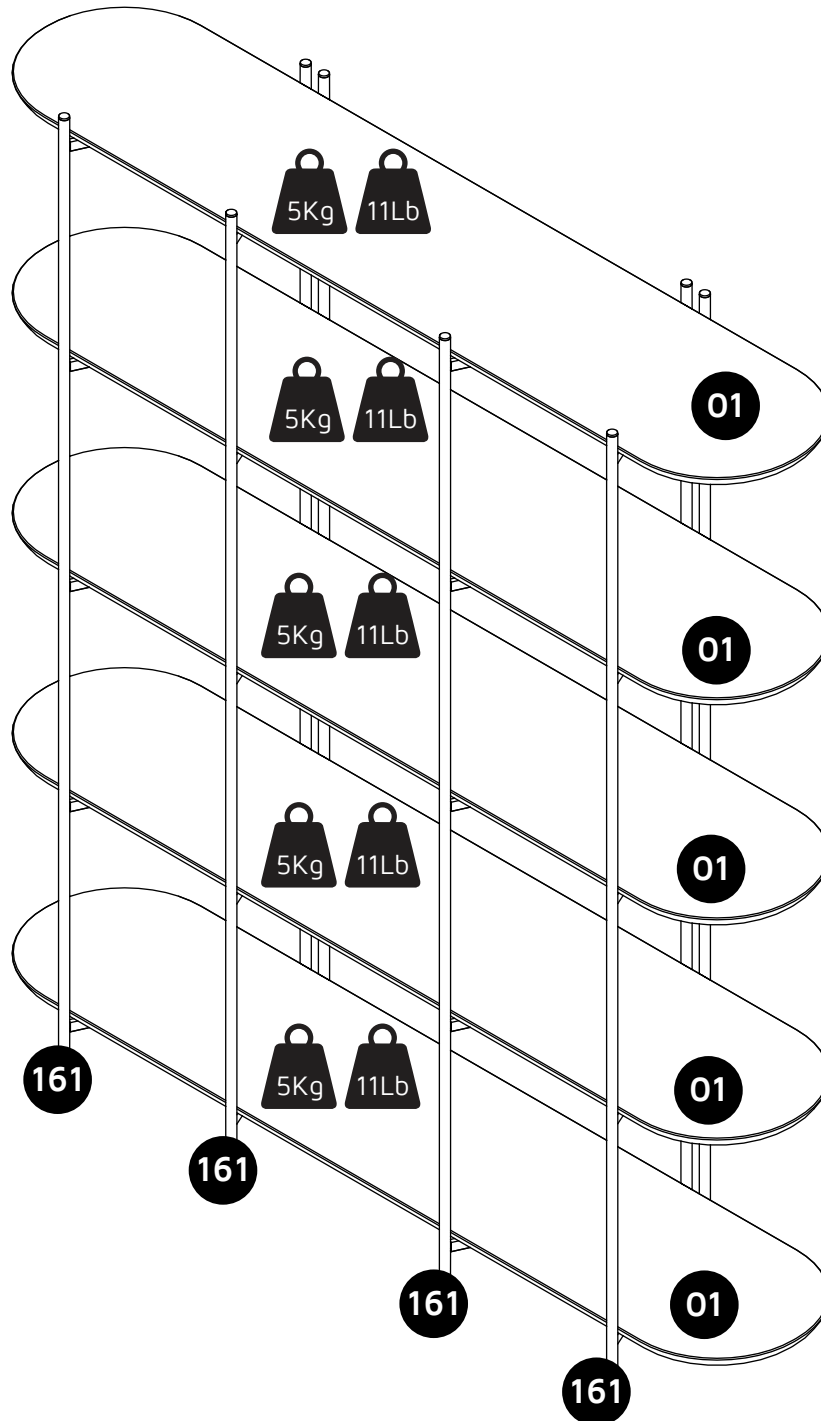

01

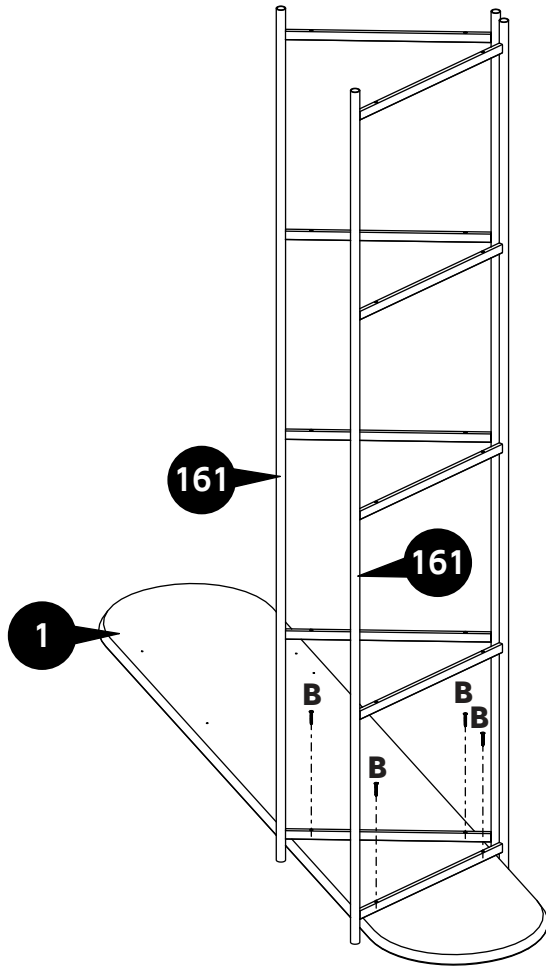
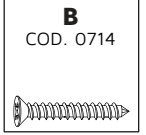

PASSO 01

Parafusar **4x (B)** na peça **161** com peças **01**

STEP 01

Screw **4x (B)** on the part **161** with part **01**

PASO 01

Atornillar **4x (B)** en la pieza **161** con la pieza **01**

Étape 01

Visser **4x (B)** sur le pièce **161** avec sur le pièce **01**

02

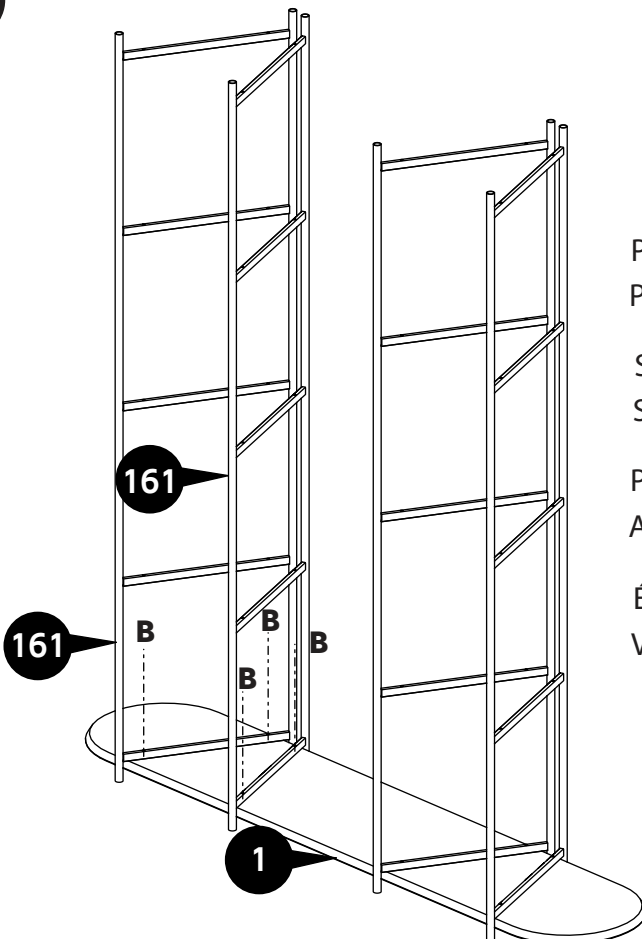

PASSO 02

Parafusar **4x (B)** na peça **161** com peças **01**

STEP 02

Screw **4x (B)** on the part **161** with part **01**

PASO 02

Atornillar **4x (B)** en la pieza **161** con la pieza **01**

Étape 02

Visser **4x (B)** sur le pièce **161** avec sur le pièce **01**

03

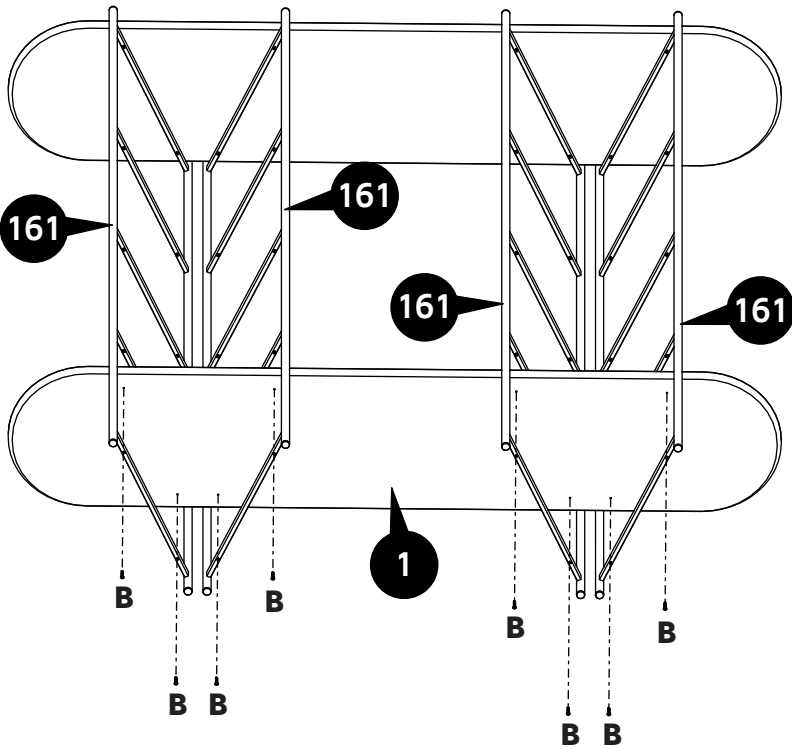
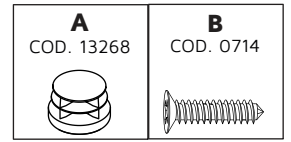

PASSO 03

Parafusar **8x (B)** na peça **161** com peças **01**

STEP 03

Screw **8x (B)** on the part **161** with part **01**

PASO 03

Atornillar **8x (B)** en la pieza **161** con la pieza **01**

Étape 03

Visser **8x (B)** sur le pièce **161** avec sur le pièce **01**

04

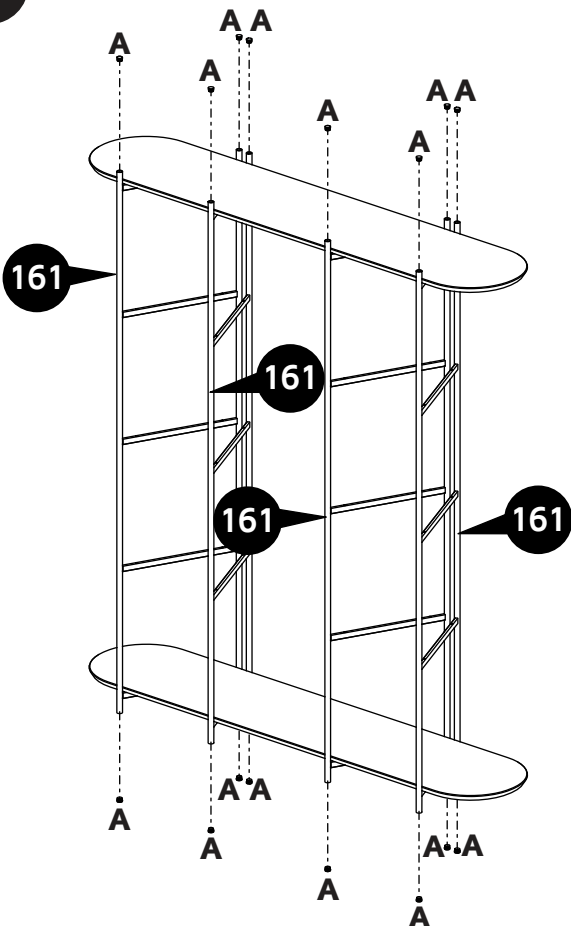

PASSO 04

Inserir o item **16x (A)** na peça **161**

STEP 04

Insert the item **16x (A)** into the part **161**

PASO 04

Ensamble las pieza **16x (A)** en la piezas **161**

Étape 04

Insérez l'èlément **16x (A)** dans la pièce **161**

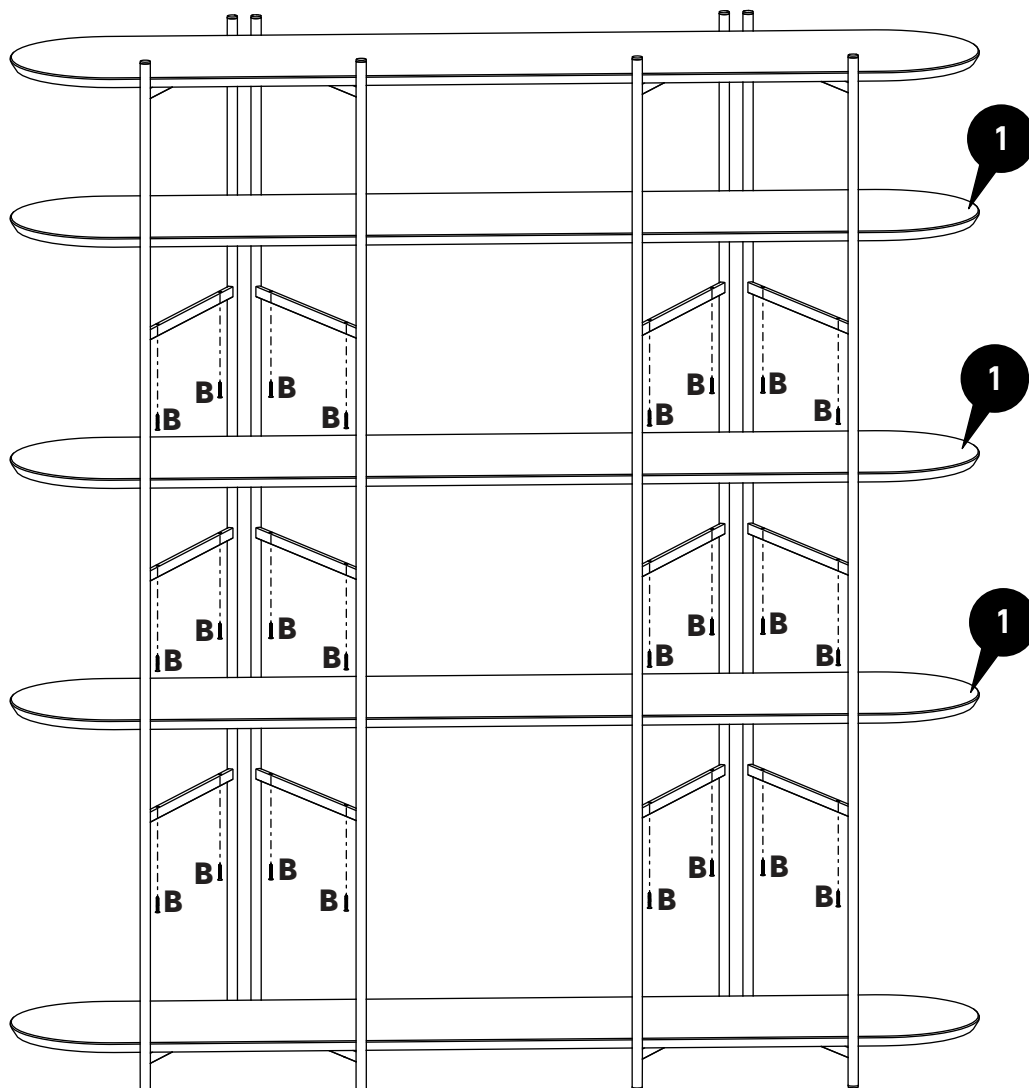

PASSO 05

Parafusar **24x (B)** na peça **161** com peças **01**

STEP 05

Screw **24x (B)** on the part **161** with part **01**

PASO 05

Atornillar **24x (B)** en la pieza **161** con la pieza **01**

Étape 05

Visser **24x (B)** sur le pièce **161** avec sur le pièce **01**