

Ref.	Descrição	Dimensões (mm)	Quant.
1	BASE	1361 X 600 X 15	01
2	CHAPÉU	1361 X 600 X 15	01
3	LATERAL ESQUERDA	2350 X 600 X 15	01
4	LATERAL DIREITA	2350 X 600 X 15	01
5	DIVISÓRIAS	2260 X 525 X 15	01
6	PRATELEIRA	673 X 520 X 15	08
7	TAMPO DO CALCEIRO	673 X 360 X 15	01
8	ESPAÇADOR DO GAVETEIRO	585 X 80 X 15	04
9	RODAPÉ	1361 X 60 X 15	02
10	FUNDO	2290 X 339 X 3	04
11	FUNDO GAVETA	617 X 450 X 3	03
12	FRENTE DA GAVETA	635 X 170 X 15	03
13	LATERAIS DA GAVETA	450 X 150 X 15	06
14	CONTRAFUNDO GAVETA	587 X 150 X 15	06
15	GABARITO P/ PRATELEIRA	70 X 200	01
16	GABARITO P/ PRATELEIRA	70 X 310	01

A	Cavilha 6 x 30	12	
B	Parafuso 3,5 x 16mm	100	
C	Parafuso 4,0 x 25mm	20	
D	Parafuso 4,0 x 40mm	20	
E	Suporte Cabideiro	04	
F	Tubo Cabideiro 667mm	02	
G	Parafuso Flangeado 3,5 x 16mm	36	
H	Cantoneira metálica 2 Furos	32	
I	Prego 10 x 10	50	
J	Tapa Furo	16	
K	Corrediça Telescópica 350mm	03 PARES	
L	Parafuso 4,0 x 35mm	24	
M	Perfil H 2290mm	02	
N	Junção de Fundo	10	

\*ATENÇÃO. Todas as prateleiras são fixadas com cantoneiras, EXETO a prateleira que vai em cima das gavetas que será fixada com parafusos.

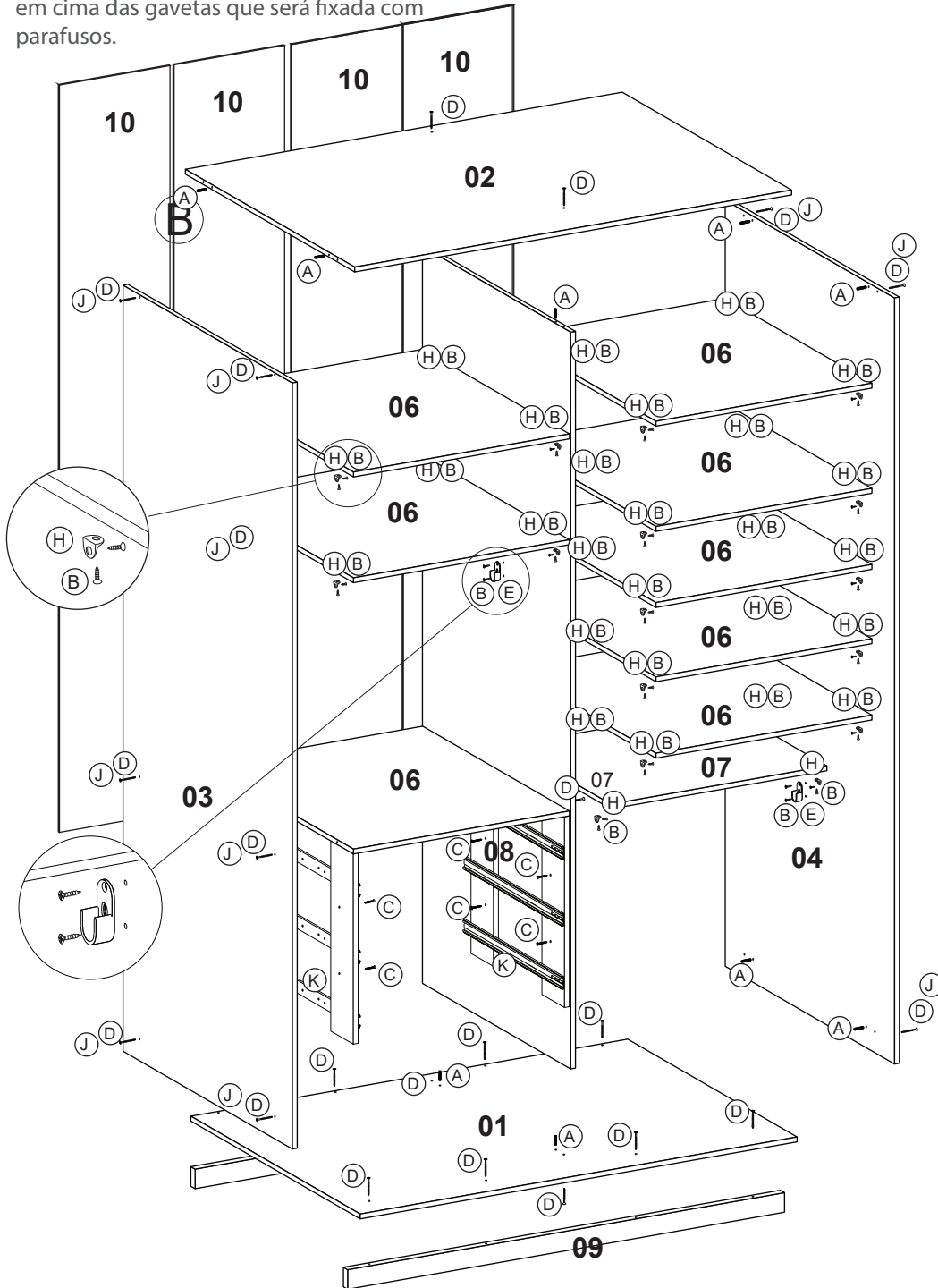
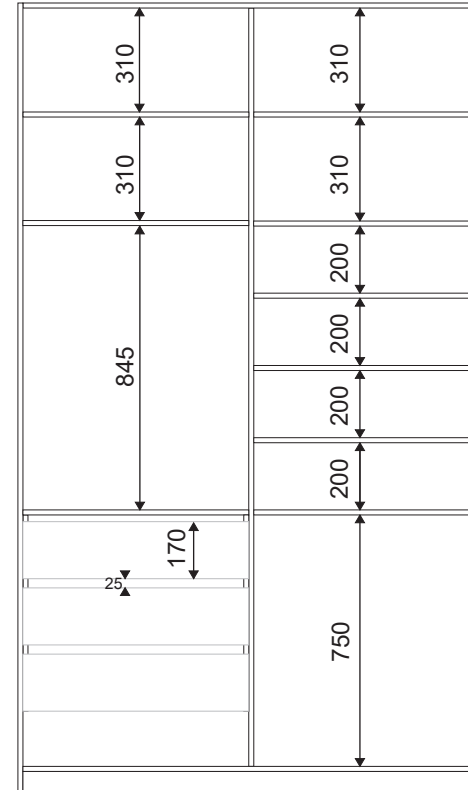

Fig.1 Medidas do entre vão



\*ATENÇÃO. Confira medidas do entre vão para fixação das prateleiras com espaçamento indicado na figura 1.

\*ATENÇÃO. As cantoneiras devem ser fixadas nos quatro cantos de cada prateleira à 64mm. E com apoio do GABARITO pode ser feita a fixação no roupeiro na altura correta.

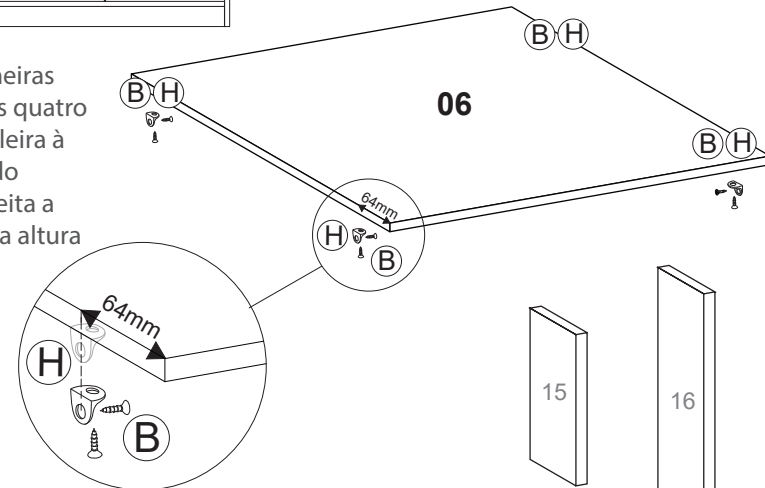
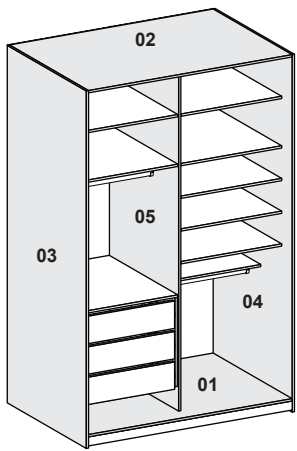



Fig.15 GABARITO P/ PRATELEIRA 70x200 mm

Fig.16 GABARITO P/ PRATELEIRA 70x310 mm



- 01. Base
- 02. Chapéu
- 03. Lateral Esquerda
- 04. Lateral Direita
- 05. Divisória

 Indicação de estrutura, furo a 64mm vazia.

1. Base\_Furação Interna\_1361X600X15mm

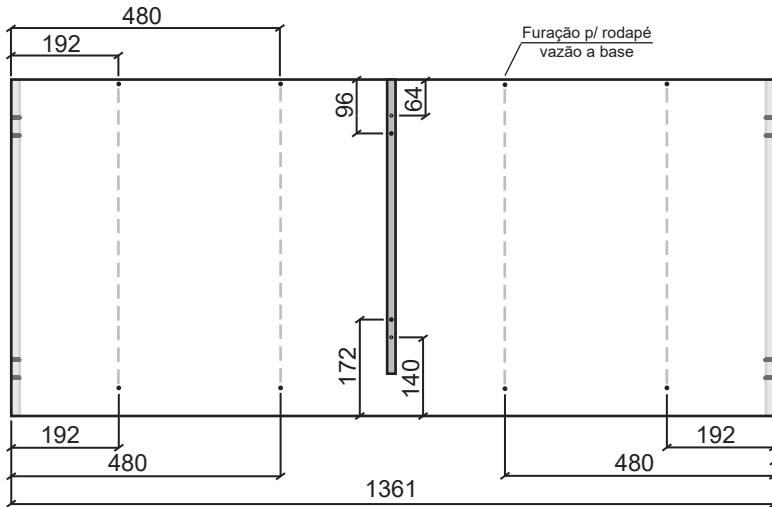

2. Chapéu\_Furação Interna\_1361X600X15mm

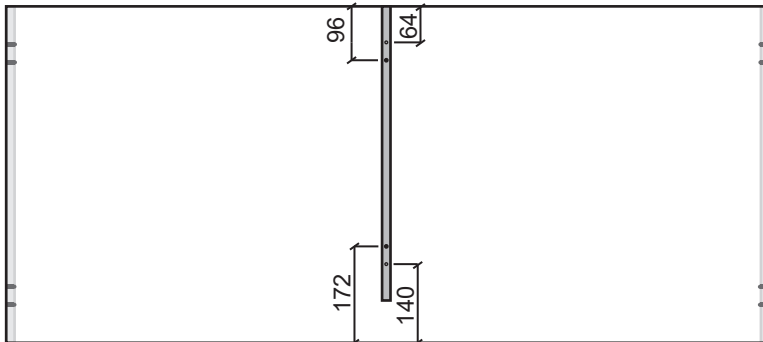

3. Lateral Esquerda\_Furação Interna\_2350X600X15mm

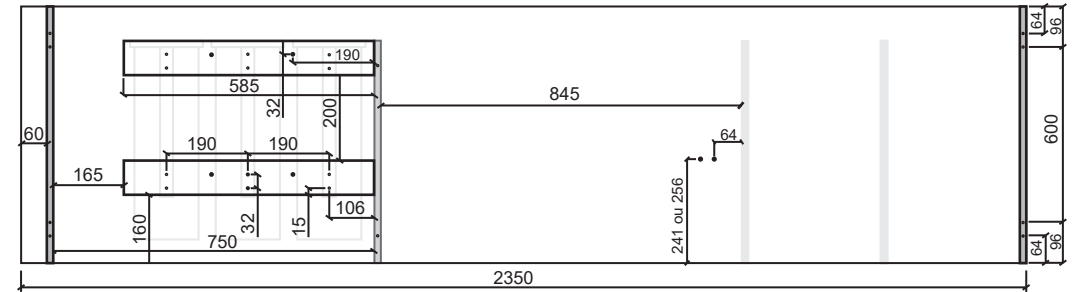

4. Lateral Direita\_Furação Interna\_2350X600X15mm

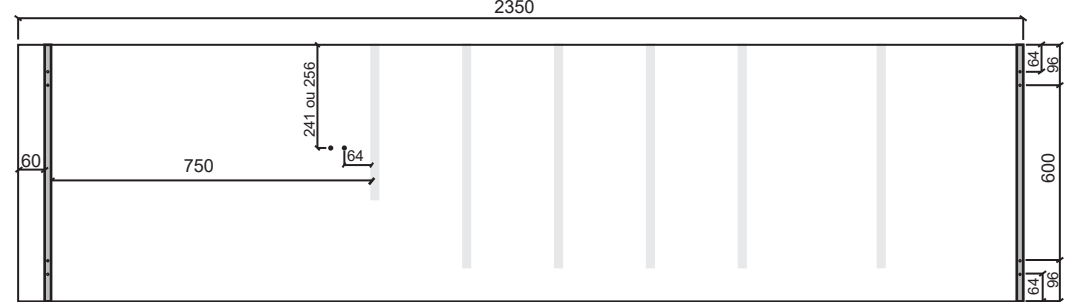

5. Divisória\_Furação Face voltada p/ Lateral Esquerda\_2260X525X15mm

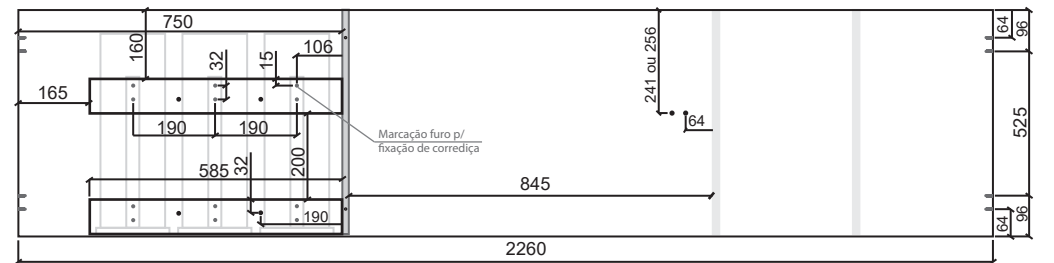

Divisória\_Furação Face voltada p/ Lateral Direita\_2260X525X15mm

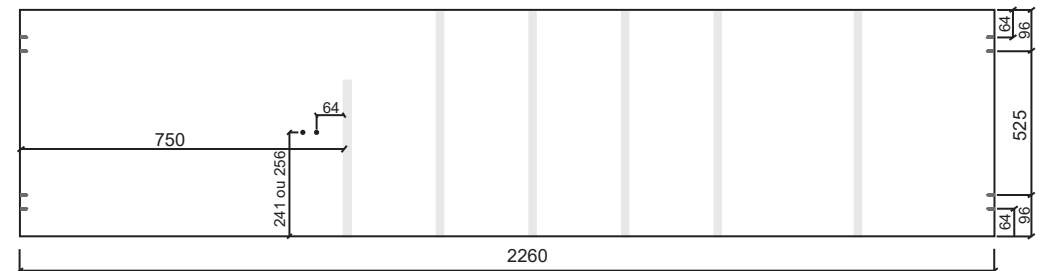

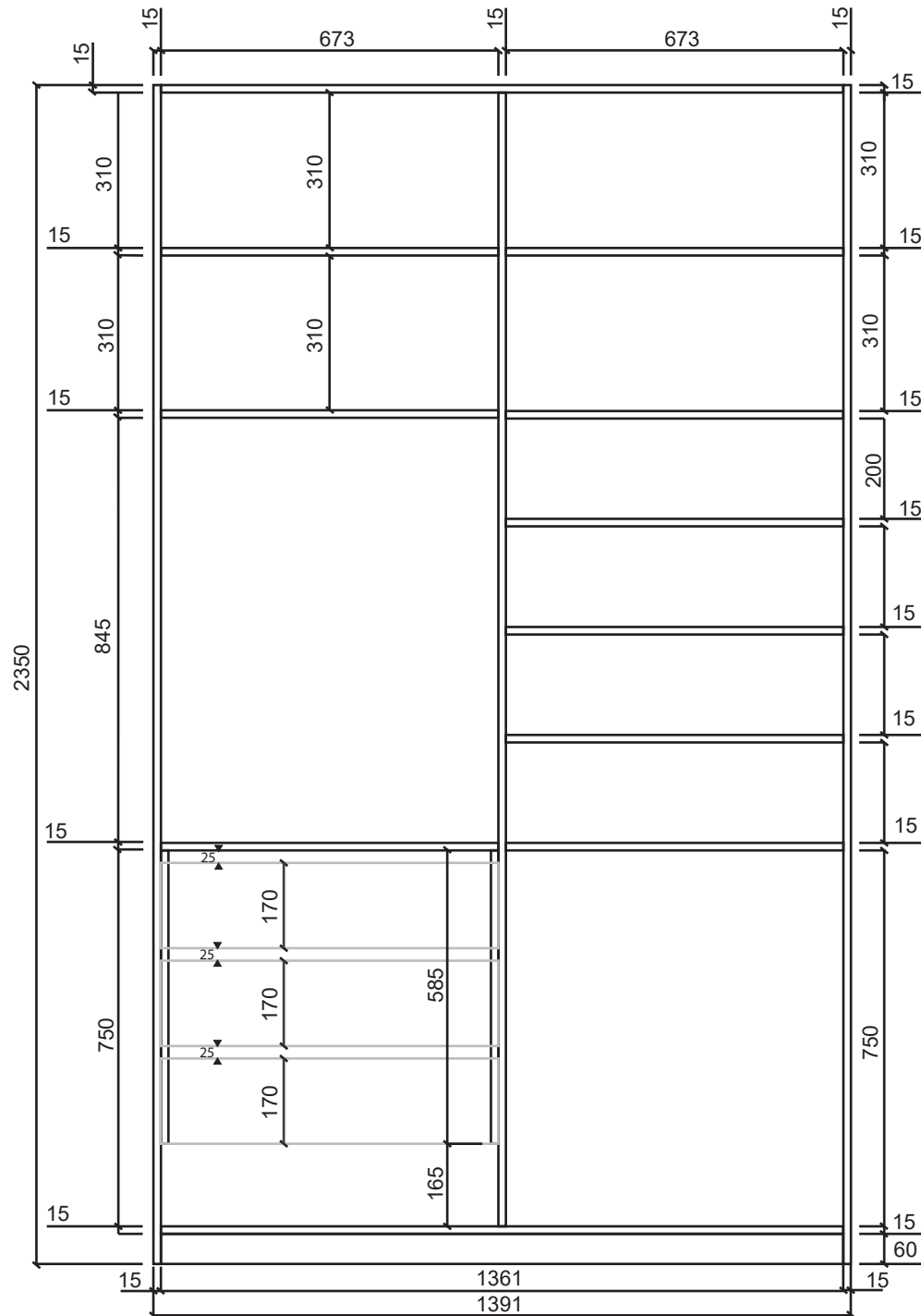

## Vista Ortogonal

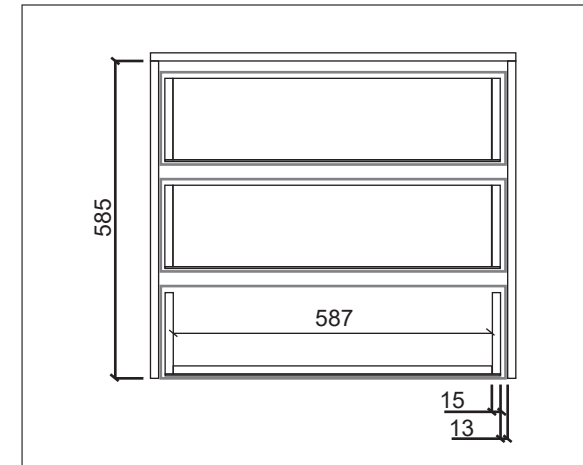

\*ATENÇÃO 13mm é a espessura da corrediça

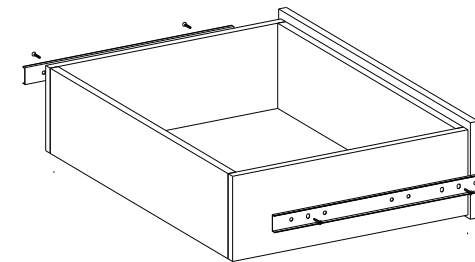



### MONTAGEM GAVETAS

