

MANUAL DE MONTAGEM / PLANO DE ARMADO / ASSEMBLY INSTRUCTIONS

Parabéns! Você comprou um produto de excelente qualidade, fabricado com chapa de madeira de MDP ou MDF, extraída de florestas renováveis. Possui alta resistência e design atual.

Felicitaciones! Usted compró a un producto de excelente calidad, fabricado con placa de madera de MDP o MDF, proveniente de florestas renovables. Tiene alta resistencia y diseño actual.

Congratulations! You have purchased a product of excellent quality, made with MDP or MDF wood veneer, extracted from renewable forests. It has high strength and current design.

Antes de montar o móvel, leia com atenção o manual de montagem!

Antes de armar el mueble, lea con atención el manual de ensamble!

Before assembling the furniture, carefully read the assembly manual!



ATENÇÃO:
ATENCIÓN:
WARNING:

- 1) Verifique todas as peças antes de começar a montagem.**
Verifique todas las partes antes de empezar el armado.
Check all parts before starting assembly.
- 2) Ao começar a montagem, não apoie as peças na parede.**
Al empezar el armado, no apoyes las partes en la pared.
When starting the assembly, do not support the parts against the wall.
- 3) Ao colocar as peças e ferragens de lado, cuidado para não perde-las.**
Al poner las piezas y herrajes a parte, cuidado para no dañarlas.
When putting parts and hardware aside, be careful not to lose them.
- 4) O móvel deve ser montado no chão, para isso, use a própria caixa para proteger e não danificar o piso.**
El mueble suele ser armado al piso, para eso, use la propia caja para protegerlo y no dañar al piso.
The furniture must be mounted on the floor, for this, use the box itself to protect and not damage the floor.
- 5) Comece a montagem seguindo as instruções passo a passo.**
Comience el armado siguiendo la instrucciones paso a paso.
Begin assembly by following the step-by-step instructions.
- 6) É de responsabilidade do montador seguir as intruções desse manual, que são fundamentais para a estrutura do móvel.**
Es de responsabilidad del armador seguir las instrucciones de este manual, que son fundamentales para la estructura del mueble.
It is the responsibility of the assembler to follow the instructions in this manual, which are fundamental for the structure of the furniture.

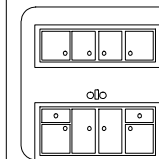

- 1) A conservação e limpeza deve ser feita com um pano levemente umedecido com água.**
La conservación y limpieza debe ser hecha con un trapo levemente humedecido en agua.
Maintenance and cleaning should be done with a cloth slightly dampened with water.
- 2) Não use produtos abrasivos, como saponáceo, detergentes e esponja de aço.**
No use productos abrasivos, como saponáceo, detergentes y esponja de acero.
Do not use abrasive products such as soap, detergents and steel sponge.

CUIDADOS:
CUIDADOS:
CAUTIONS:

- 3) Não use cera ou óleo para dar brilho ao móvel.**
No use cera o aceites para darle brillo al mueble.
Do not use wax or oil to shine the furniture.
- 4) Não expor o móvel a interpéries e nem ao calor excessivo.**
No exponer el mueble a interperies ni al calor excesivo.
Do not expose the furniture to weather or excessive heat.
- 5) Ao terminar a montagem, limpe o ambiente e o móvel.**
Al terminar el armado, limpie al ambiente y al mueble.
When finishing the assembly, clean the environment and the furniture.

FERRAMENTAS:
HERRAMIENTAS:
TOOLS:



Martelo de borracha
Martillo Goma
Rubber hammer



Martelo
Martillo
Hammer



Chave Phillips
Llave Phillips
Phillips screwdriver



Trena
Cinta métrica
Tape measure



Parafusadeira
Destornillador Eléctrico
Drill/Elétric Screwdriver

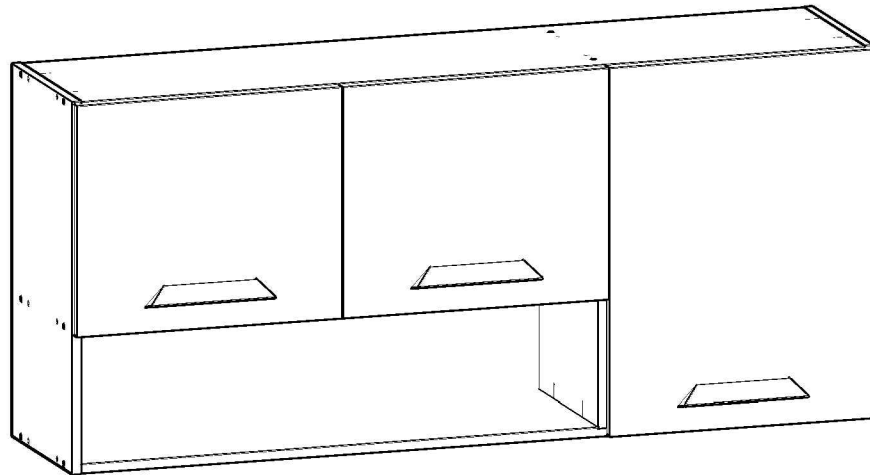

Ref.: 1020

Antes de começar a montagem certifique-se que as caixas estão em perfeitas condições.
Antes de empezar el armado asegúrese que las cajas estén en perfectas condiciones.

Before starting assembly, make sure the boxes are in perfect condition.

LISTA DE PEÇAS / LISTA DE PIEZAS / LIST OF PIECES

Nº	Descrição / Descripción / Description	Qtd. Cant.
1	Lateral direita / Lateral derecha / Right side	1
2	Lateral esquerda / Lateral izquierda / Left side	1
3	Base / Base / Bottom	1
4	Tampo / Tope / Top	1
5	Divisória / Divisoria / Division	1
6	Prateleira / Repisa / Shelf	1
7	Porta direita / Puerta derecha / Right door	1
8	Porta esquerda / Puerta izquierda / Left door	2
9	Costa direita / Trasero derecho / Right back	1
10	Costa esq. sup / Trasero izq. sup / Upper left back	1
11	Costa esq. inf / Trasero izq inf / Lower left back	1

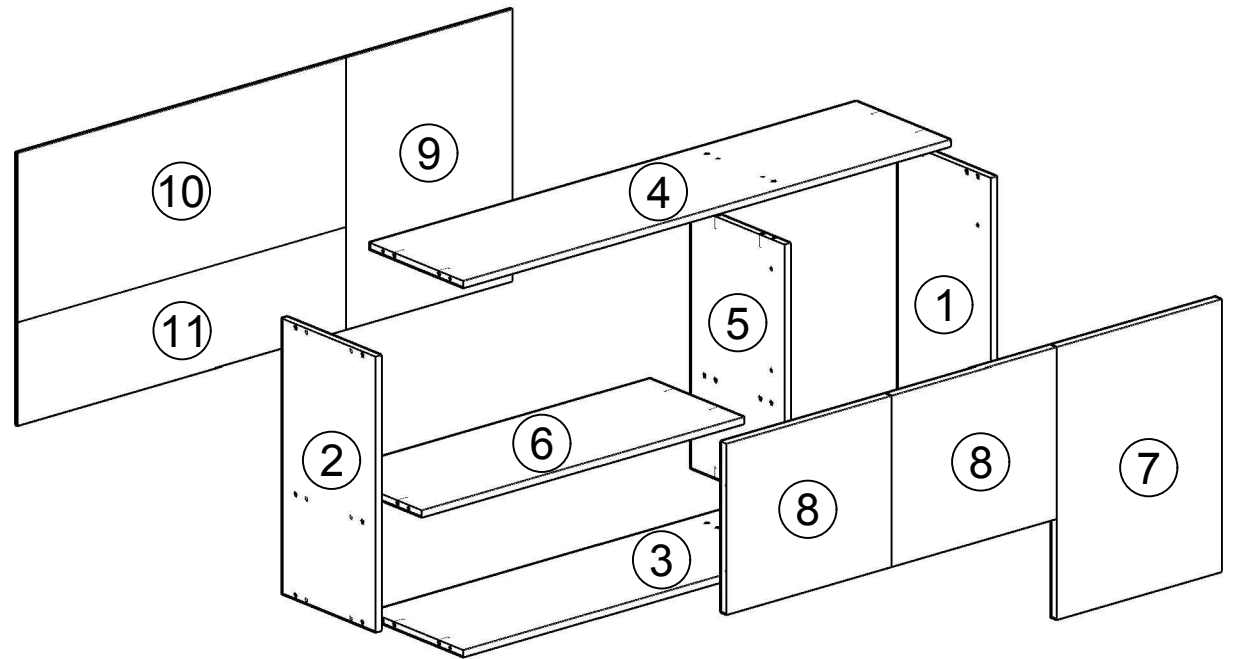

LISTA DE FERRAGENS / LISTA DE HERRAJES / HARDWARE LIST		
ITEM / ITEM	DESCRIÇÃO / DESCRIPCIÓN / DESCRIPTION	QTD. / CANT.
C2	CAVILHA 6X30 / TARUGO 6X30 / WOODEN DOWEL 6X30	16
P2	PARAFUSO 4X22 / TORNILLO 4X22 / SCREW 4X22	2
P6	PARAFUSO 3,5X40 / TORNILLO 3,5X40 / SCREW 3,5X40	16
P7	PARAFUSO 4X12 / TORNILLO 4X12 / SCREW 4X12	28
P25	PARAFUSO 3,5X25 / TORNILLO 3,5X25 / SCREW 3,5X25	6
P39	PARAFUSO 5X50 / TORNILLO 5X50 / SCREW 5X50	2
D1	CALÇO DE DOBRADIÇA / CALZO DE BISAGRA / HINGE SHIM	6
D2	DOBRADIÇA / BISAGRA / HINGE	6
PX	PUXADOR / TIRADOR / HANDLE	3
R1	PREGO 10X10 / CLAVO 10X10 / NAIL 10X10	36
GR	GARRA METÁLICA / GRAB METÁLICA / METALLIC CLAW	8
SF	SUPOORTE DE FIXAÇÃO / SOPORTE DE FIJACIÓN / MOUNTING BRACKET	2
BU	BUCHA / BUJE / BUSH	2
CS	CAPA PARA SUPORTE / CUBIERTA PARA SOPORTE / SUPPORT COVER	2

USE A RÉGUA PARA IDENTIFICAR OS PARAFUSOS
 UTILICE LA REGLA PARA IDENTIFICAR LOS TORNILLOS
 USE THE RULER TO IDENTIFY THE SCREWS

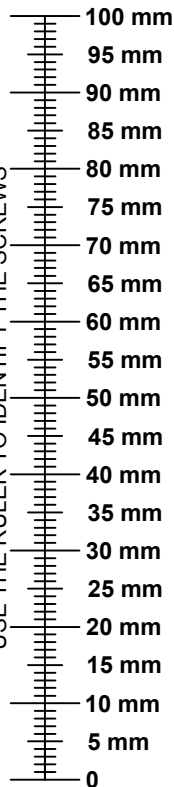

1

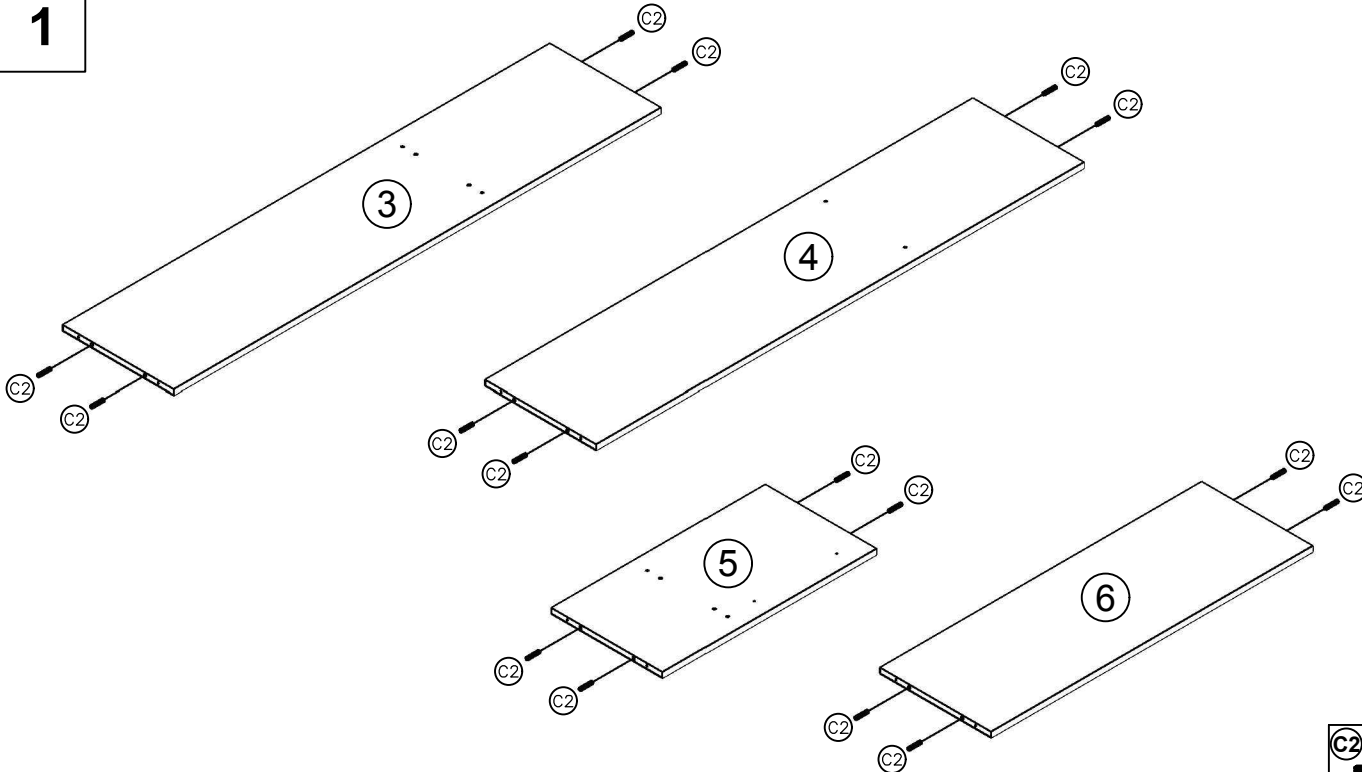

C2
16X

2

MONTE A ESTRUTURA DO MÓVEL
 ARME LA ESTRUCTURA DEL MUEBLE
 ASSEMBLE THE FURNITURE STRUCTURE

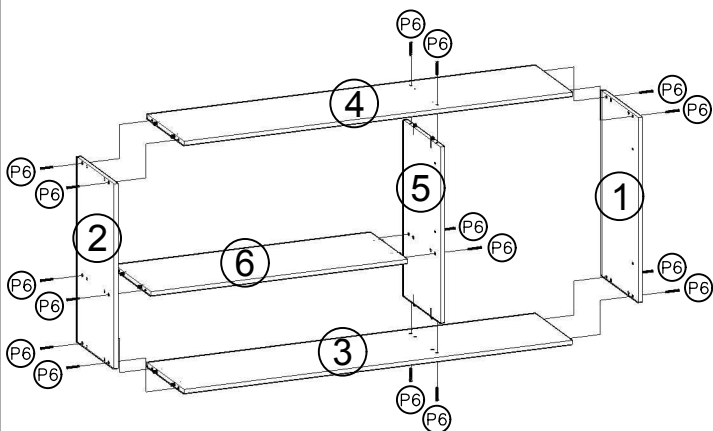

P6
16X

3

FIXE OS SUPORTES DE FIXAÇÃO
 NAS LATERAIS (1 E 2)
 FIJE LOS SOPORTES DE FIJACIÓN
 EN LAS LATERALES (1 Y 2)
 FIX THE FIXING BRACKETS ON THE SIDE
 (1 AND 2)

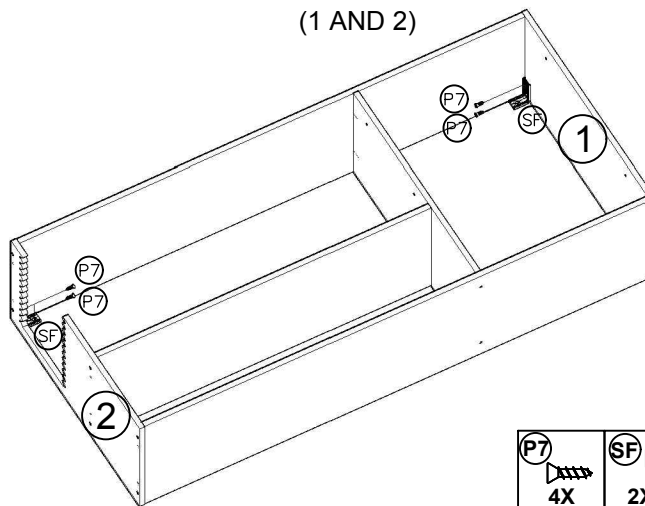

P7 4X
SF 2X

4

COLOQUE AS COSTAS (9, 10 E 11)
 PONGA LOS TRASEROS (9, 10 Y 11)
 INSTALL BACK (9, 10 AND 11)

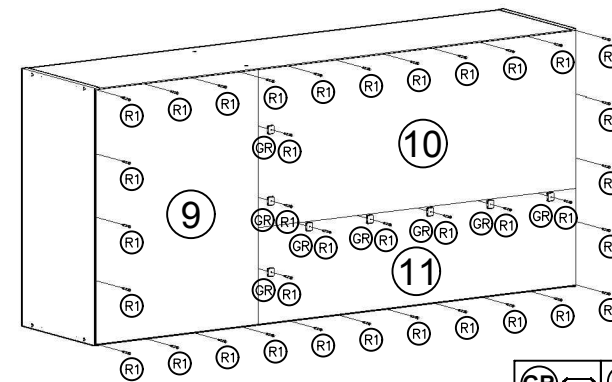

GR 8X
R1 36X

5

ATRAVÉS DOS SUPORTES DE FIXAÇÃO "SF", BUCHAS "BU" E PARAFUSOS "P39" FIXE O MÓVEL NA PAREDE. A FIXAÇÃO DEVE SER REALIZADA NA PARTE SUPERIOR DO MÓVEL
ATRÁVÉS DE LOS SOPORTES DE FIJACIÓN "SF", TACOS "BU" Y TORNILLOS "P39" REALIZAR LA FIJACIÓN DEL MUEBLE EN LA PARED. LA FIJACIÓN SE DEBE REALIZAR EN LA PARTE SUPERIOR DEL MUEBLE.
THROUGH THE FIXING SUPPORTS "SF", BUSHINGS "BU" AND SCREWS "P39" FIX THE FURNITURE TO THE WALL. FIXING MUST BE PERFORMED ON THE TOP OF THE FURNITURE

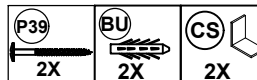
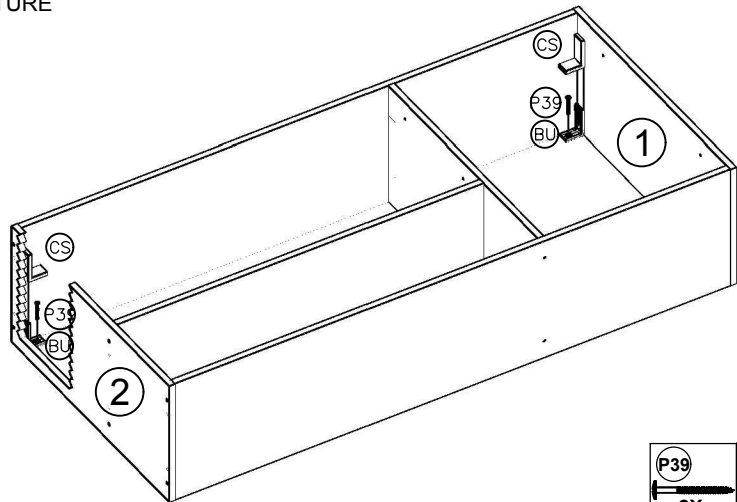

6

MONTAGEM DAS PORTAS (7 E 8)
MONTAJE DE LAS PUERTAS (7 Y 8)
ASSEMBLY OF THE DOORS (7 AND 8)

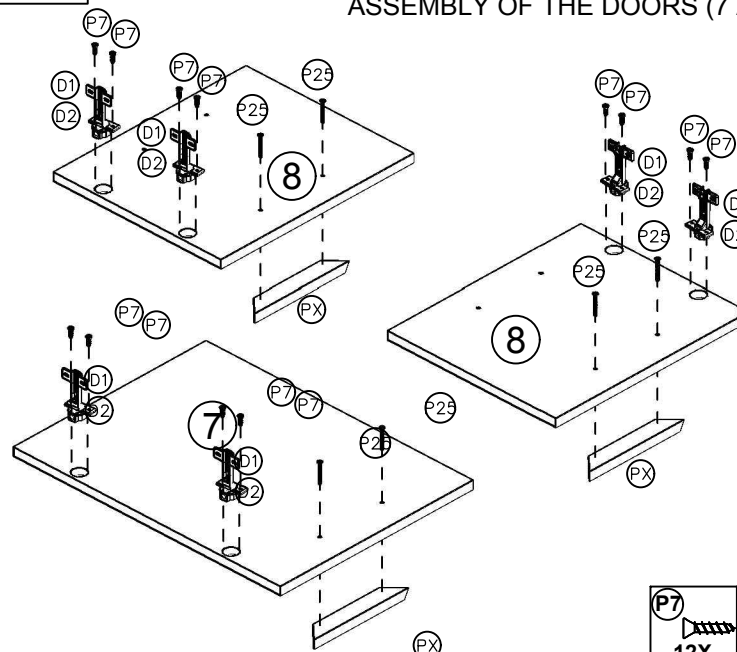

FIXAÇÃO DA PEÇA "D2" NA PEÇA "D1", PARA DEPOIS FIXAR O CONJUNTO DE DOBRADIÇAS NAS PORTAS (10 E 11)
FIJACIÓN DE LA PIEZA "D2" EN LA PIEZA "D1", PARA DESPUÉS FIJAR EL CONJUNTO DE LAS BISAGRAS EN LAS PUERTAS (10 Y 11)
FIXING THE PART "D2" TO THE PART "D1", THEN FIX THE HINGES SET ON THE DOORS (10 AND 11)

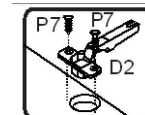
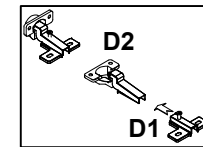

Fijación en las puertas

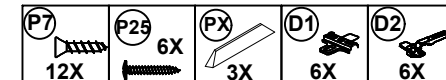

7

COLOQUE AS PORTAS (7 E 8)
PONGA LAS PUERTAS (7 Y 8)
INSTALL THE DOORS (7 AND 8)

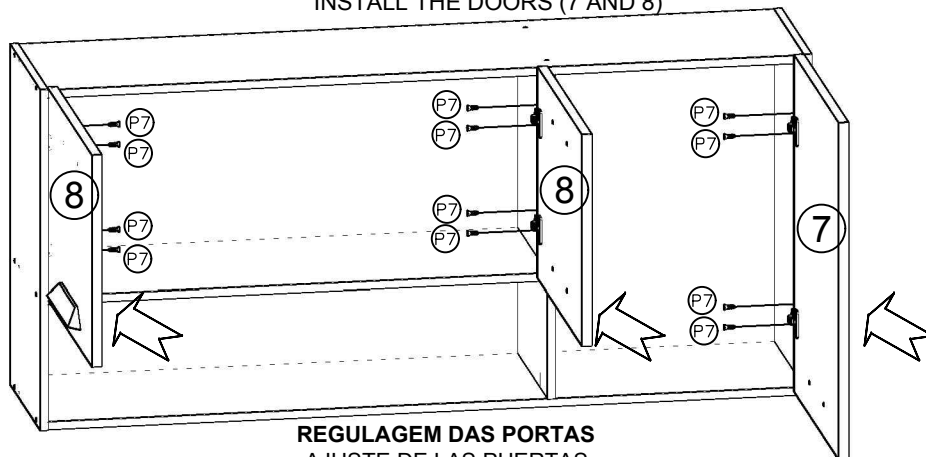

REGULAGEM DAS PORTAS
AJUSTE DE LAS PUERTAS
ADJUSTMENT OF THE DOORS

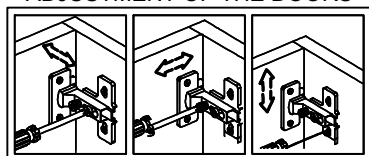

8

PARA REALIZAR A UNIÃO ENTRE DIFERENTES MÓDULOS, FAZER USO DO PARAFUSO "P2"

PARA HACER LA UNIÓN ENTRE LOS DIFERENTES MÓDULOS, UTILICE LOS TORNILLOS "P2"
TO JOIN DIFFERENT MODULES, USE OF THE SCREW "P2"

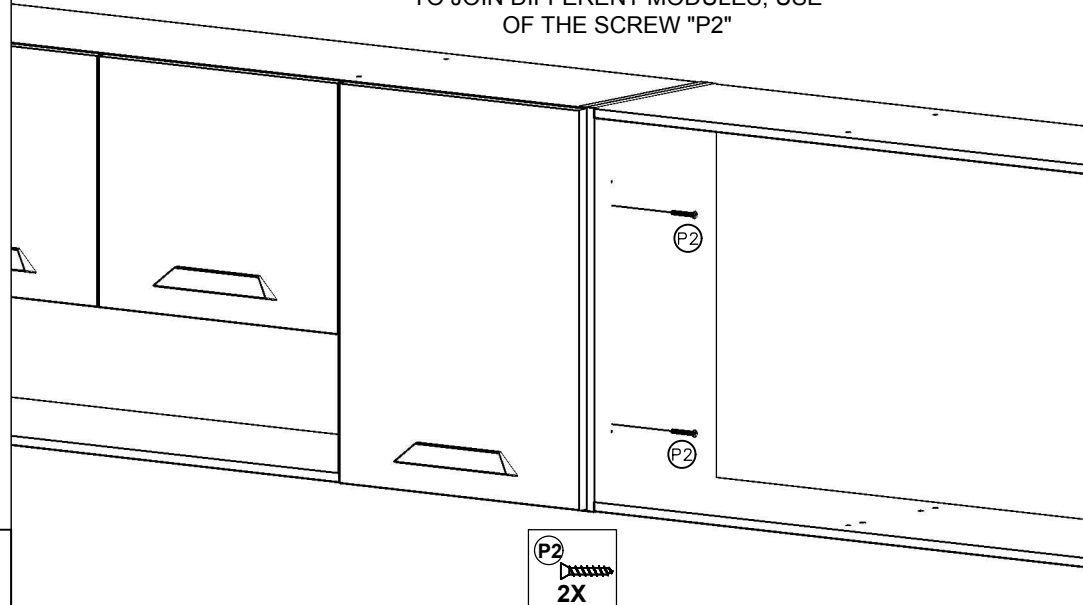

MANUAL DE MONTAGEM / PLANO DE ARMADO / ASSEMBLY INSTRUCTIONS

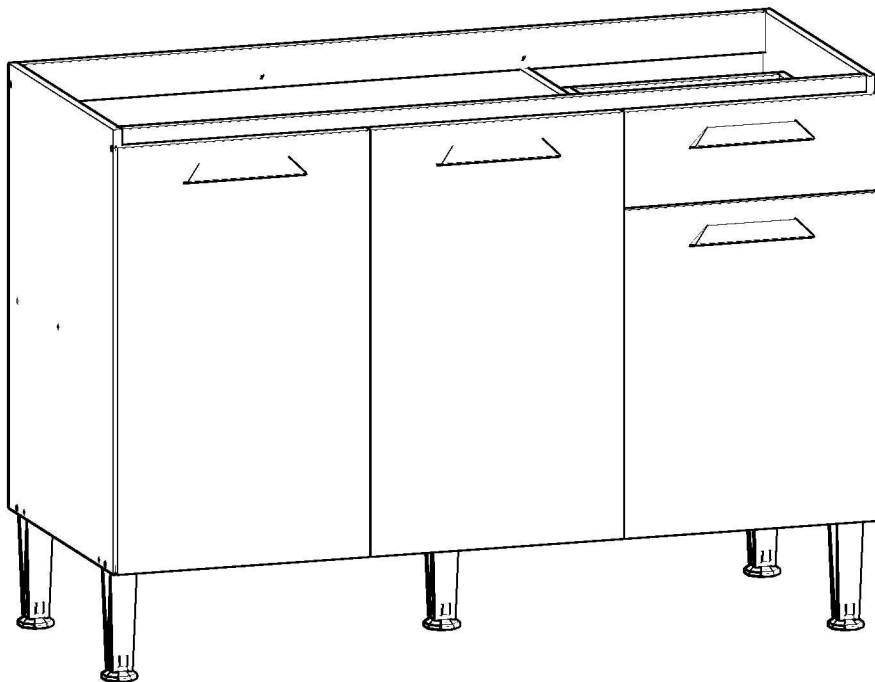

Ref.: 1012

Antes de começar a montagem certifique-se que as caixas estão em perfeitas condições.
Antes de empezar el armado asegúrese que las cajas estén en perfectas condiciones.

Before starting assembly, make sure the boxes are in perfect condition.

Parabéns! Você comprou um produto de excelente qualidade, fabricado com chapa de madeira de MDP ou MDF, extraída de florestas renováveis. Possui alta resistência e design atual.

Felicitaciones! Usted compró a un producto de excelente calidad, fabricado con placa de madera de MDP o MDF, proveniente de florestas renovables. Tiene alta resistencia y diseño actual.

Congratulations! You have purchased a product of excellent quality, made with MDP or MDF wood veneer, extracted from renewable forests. It has high strength and current design.

Antes de montar o móvel, leia com atenção o manual de montagem!

Antes de armar el mueble, lea con atención el manual de ensamble!

Before assembling the furniture, carefully read the assembly manual!



ATENÇÃO:
ATENCIÓN:
WARNING:

- 1) Verifique todas as peças antes de começar a montagem.**
Verifique todas las partes antes de empezar el armado.
Check all parts before starting assembly.
- 2) Ao começar a montagem, não apoie as peças na parede.**
Al empezar el armado, no apoyes las partes en la pared.
When starting the assembly, do not support the parts against the wall.
- 3) Ao colocar as peças e ferragens de lado, cuidado para não perde-las.**
Al poner las piezas y herrajes a parte, cuidado para no dañarlas.
When putting parts and hardware aside, be careful not to lose them.
- 4) O móvel deve ser montado no chão, para isso, use a própria caixa para proteger e não danificar o piso.**
El mueble suele ser armado al piso, para eso, use la propia caja para protegerlo y no dañar al piso.
The furniture must be mounted on the floor, for this, use the box itself to protect and not damage the floor.
- 5) Comece a montagem seguindo as instruções passo a passo.**
Comience el armado siguiendo la instrucciones paso a paso.
Begin assembly by following the step-by-step instructions.
- 6) É de responsabilidade do montador seguir as intrucões desse manual, que são fundamentais para a estrutura do móvel.**
Es de responsabilidad del armador seguir las instrucciones de este manual, que son fundamentales para la estructura del mueble.
It is the responsibility of the assembler to follow the instructions in this manual, which are fundamental for the structure of the furniture.

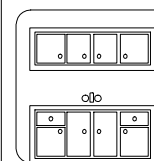

CUIDADOS:
CUIDADOS:
CAUTIONS:

- 1) A conservação e limpeza deve ser feita com um pano levemente umedecido com água.**
La conservación y limpieza debe ser hecha con un trapo levemente humedecido en agua.
Maintenance and cleaning should be done with a cloth slightly dampened with water.
- 2) Não use produtos abrasivos, como saponáceo, detergentes e esponja de aço.**
No use productos abrasivos, como saponáceo, detergentes y esponja de acero.
Do not use abrasive products such as soap, detergents and steel sponge.
- 3) Não use cera ou óleo para dar brilho ao móvel.**
No use cera o aceites para darle brillo al mueble.
Do not use wax or oil to shine the furniture.
- 4) Não expor o móvel a interperies e nem ao calor excessivo.**
No exponer el mueble a interperies ni al calor excesivo.
Do not expose the furniture to weather or excessive heat.
- 5) Ao terminar a montagem, limpe o ambiente e o móvel.**
Al terminar el armado, limpie al ambiente y al mueble.
When finishing the assembly, clean the environment and the furniture.

FERRAMENTAS:
HERRAMIENTAS:
TOOLS:

Martelo de borracha
Martillo Goma
Rubber hammer

Martelo
Martillo
Hammer



Chave Phillips
Llave Phillips
Phillips screwdriver

Trena
Cinta métrica
Tape measure

Parafusadeira
Destornillador Eléctrico
Drill/Elétric Screwdriver

LISTA DE PEÇAS / LISTA DE PIEZAS

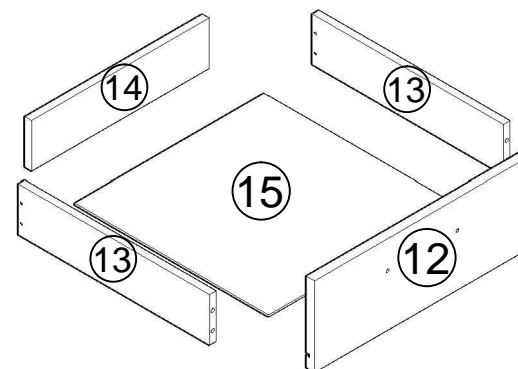
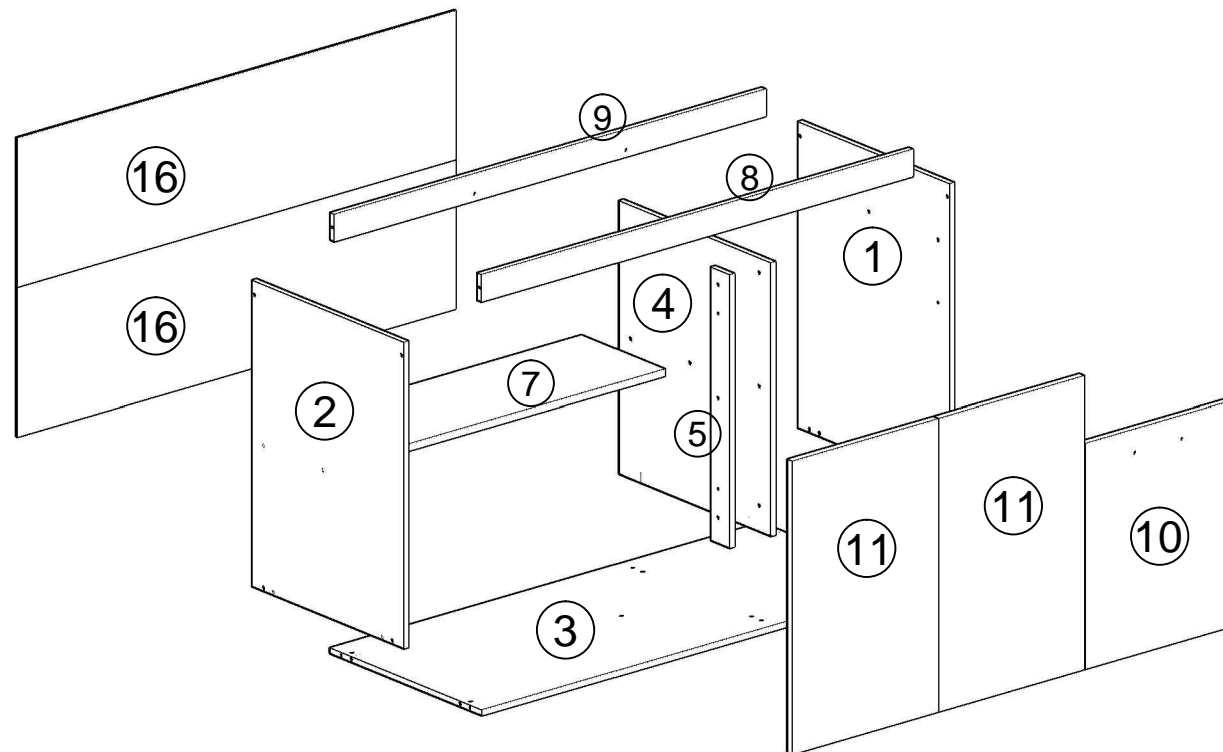
Nº	Descrição / Descripción	Qtd. Cant.
1	Lateral direita / Lateral derecha / Right side	1
2	Lateral esquerda / Lateral izquierda / Left side	1
3	Base / Base / Bottom	1
4	Divisória / Divisoria / Division	1
5	Pilastra / Pilastra / Pillar	1
7	Prateleira / Repisa / Plate panel	1
8	Travessa frontal / Travesaño frontal / Frontal plate	1
9	Travessa traseira / Travesaño trasero / Back plate	1
10	Porta direita / Puerta derecha / Right door	1
11	Porta esquerda / Puerta izquierda / Left door	2
12	Frente de gaveta / Frente del cajón / Drawer front	1
13	Lateral de gaveta / Lateral del cajón / Drawer side	2
14	Costa de gaveta / Trasero del cajón / Drawer back	1
15	Fundo de gaveta / Fondo del cajón / Drawer bottom	1
16	Costa / Trasero / Back	2



LISTA DE FERRAGENS / LISTA DE HERRAJES / HARDWARE LIST		
ITEM	DESCRICOÃO / DESCRIPCION / DESCRIPTION	QTD. CANT.
C2	CAVILHA 6X30 / TARUGO 6X30 WOODEN DOWEL 6X30	10
P2	PARAFUSO 3,5X20 / TORNILLO 3,5X20 SCREW 3,5X20	7
P6	PARAFUSO 3,5X40 / TORNILLO 3,5X40 SCREW 3,5X40	10
P7	PARAFUSO 4X12 / TORNILLO 4X12 SCREW 4X12	58
P25	PARAFUSO 3,5X25 / TORNILLO 3,5X25 SCREW 3,5X25	8
P39	PARAFUSO 5X50 / TORNILLO 5X50 SCREW 5X50	5
SU	SUPORTE DE PRATELEIRA / SOPORTE DE REPISA SHELF SUPPORT	4
D1	CALÇO DE DOBRADIÇA / CALZO DE BISAGRA HINGE SHIM	6
D2	DOBRADIÇA / BISAGRA HINGE	6
PX	PUXADOR / TIRADOR HANDLE	4
LZ	CANTONEIRA 2 FUROS / CANTONERA 2 AGUJEROS ANGLE 2 HOLES	2
L4	CHAPA "L" 4 FUROS / PLACA "L" 4 AGUJEROS PLATE "L" 4 HOLES	6
PE	PÉ / PIE LEG	5
R1	PREGO 10X10 / CLAVO 10X10 NAIL 10X10	50
R2	PREGO ANELADOS / CLAVO ANILLADOS RINGED NAILS	4
CR	CORREDEÇA / CORREDERA SLIDE	1
PI	PERFIL / PERFIL / PROFILE	1

USE A RÉGUA PARA IDENTIFICAR OS PARAFUSOS
UTILICE LA REGLA PARA IDENTIFICAR LOS TORNILLOS
USE THE RULER TO IDENTIFY THE SCREWS

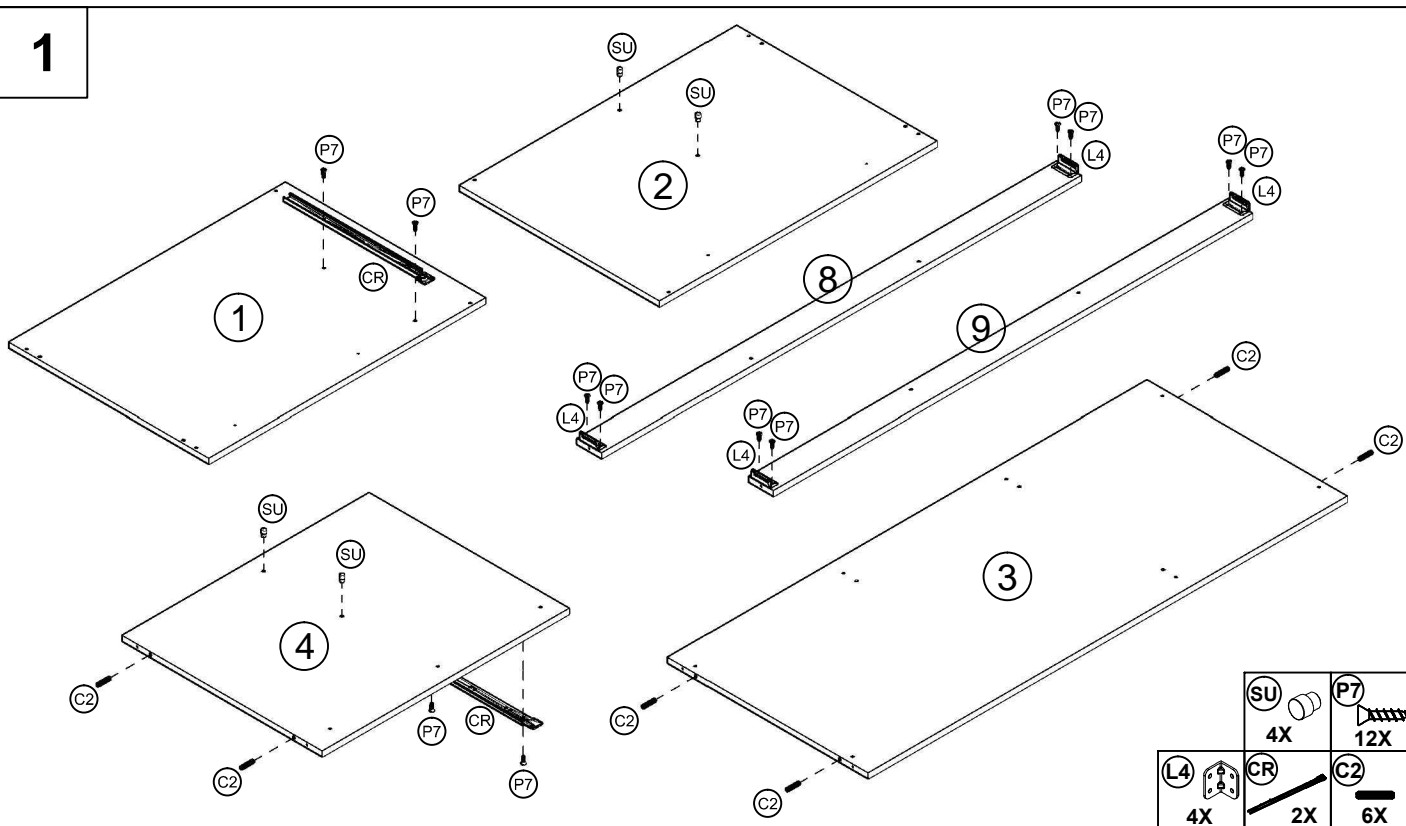
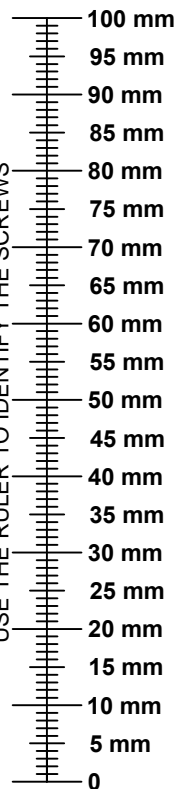

2

MONTE A ESTRUTURA DO MÓVEL
ARME LA ESTRUCTURA DEL MUEBLE
ASSEMBLE THE FURNITURE STRUCTURE

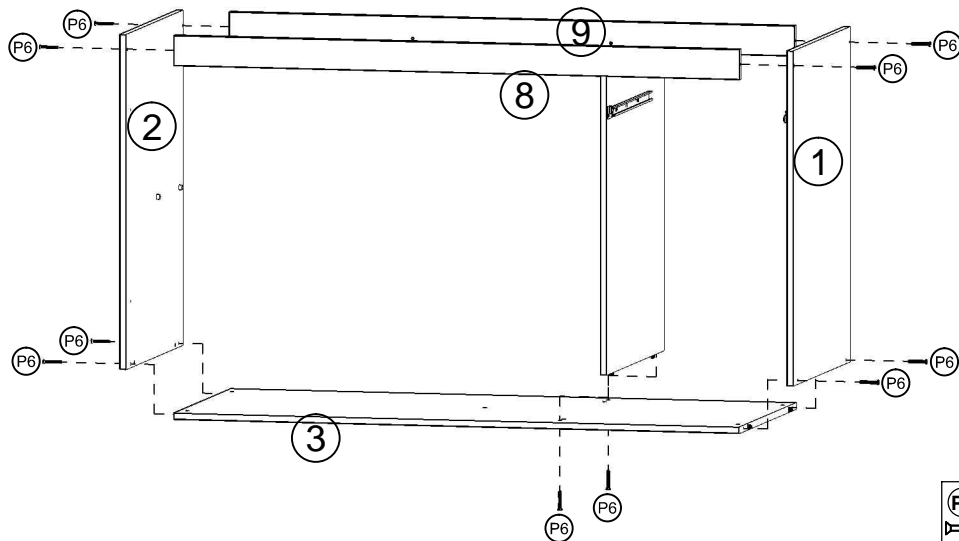

3

FIXE A PILASTRA MAIOR (5) NA DIVISÓRIA (4)
FIJE LA PILASTRA GRANDE (5) EN LA DIVISORIA (4)
FIX THE PILLAR (5) ON THE DIVISION (4)

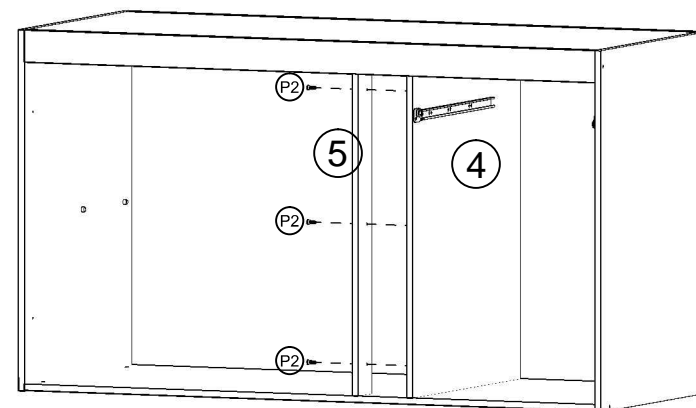

4 **FIXE AS TRAVESSAS (8 E 9) UTILIZANDO AS CHAPINHAS "L4"**
 FIJE LOS TRAVESAÑOS (8 Y 9) USANDO LAS PLACAS "L4"
 ATTACH THE PLATE PANEL (8 AND 9) USING THE "L4" PLATES

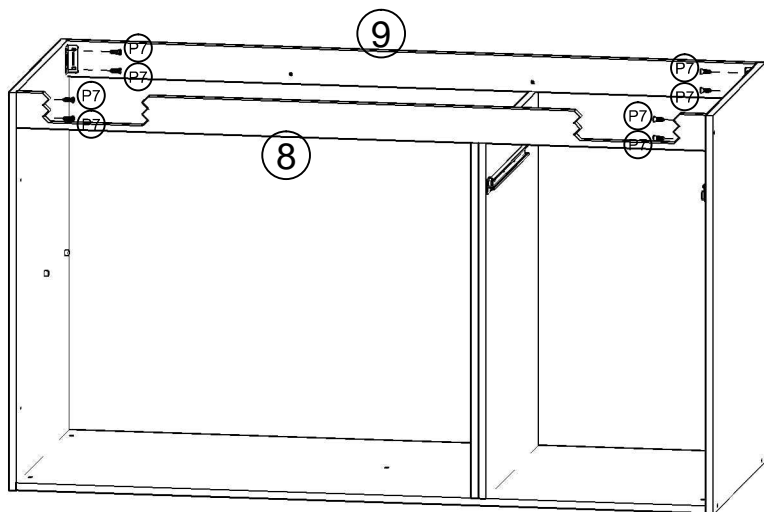

5 **FIXE AS TRAVESSAS (8 E 9) NA DIVISÓRIA (4)**
 FIJE LOS TRAVESAÑOS (8 Y 9) EN LA DIVISORIA (4)
 ATTACH THE PLATES (8 AND 9) TO THE DIVISION (4)

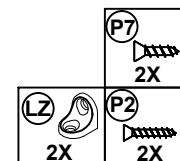
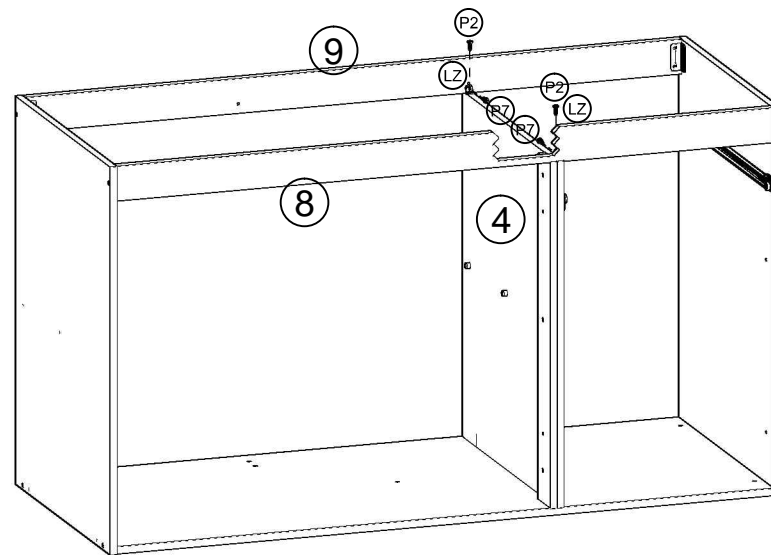

6 **Atenção! Caso sua compra for com rodapé, não efetue a instalação dos pés, siga o manual que vem com a embalagem do rodapé.**

COLOQUE OS PÉS "PE"
PONGA LAS PATAS "PE"
INSTALL THE FEET "PE"

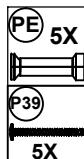
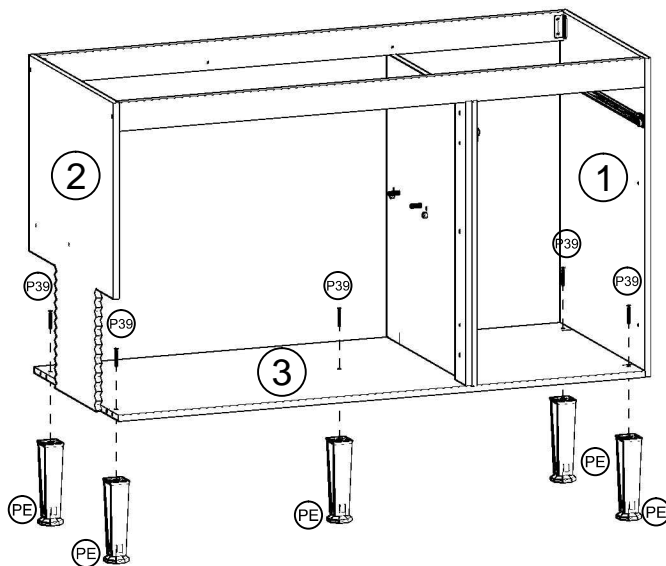

7 **COLOQUE AS COSTAS (16)**
PONGA LOS TRASEROS (16)
INSTALL BACK (16)

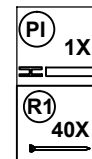
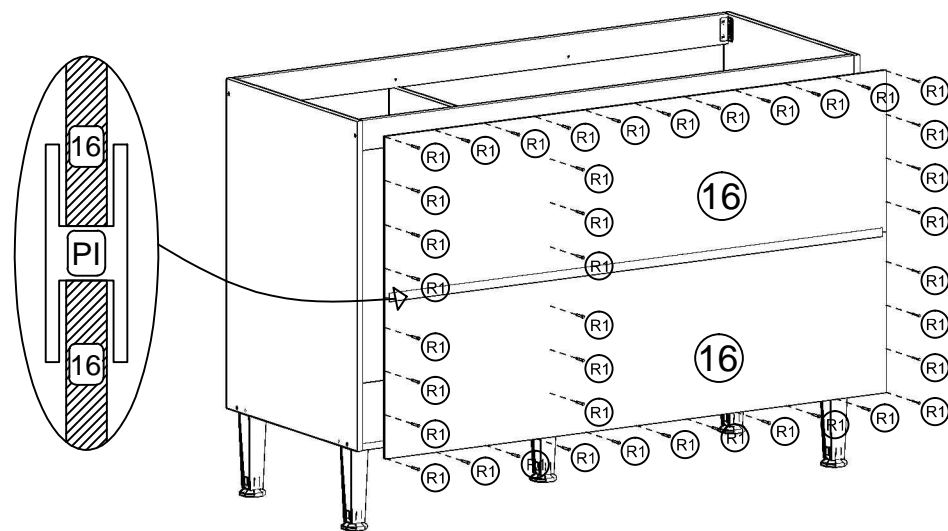

8

COLOQUE A PRATELEIRA
PONGA LA REPISA
INSTALL THE SHELF

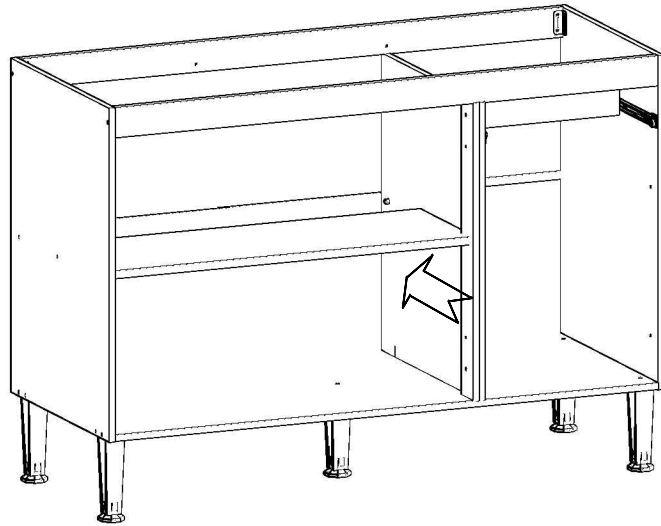

9

MONTAGEM DA GAVETA
MONTAJE DEL CAJÓN
DRAWER ASSEMBLY

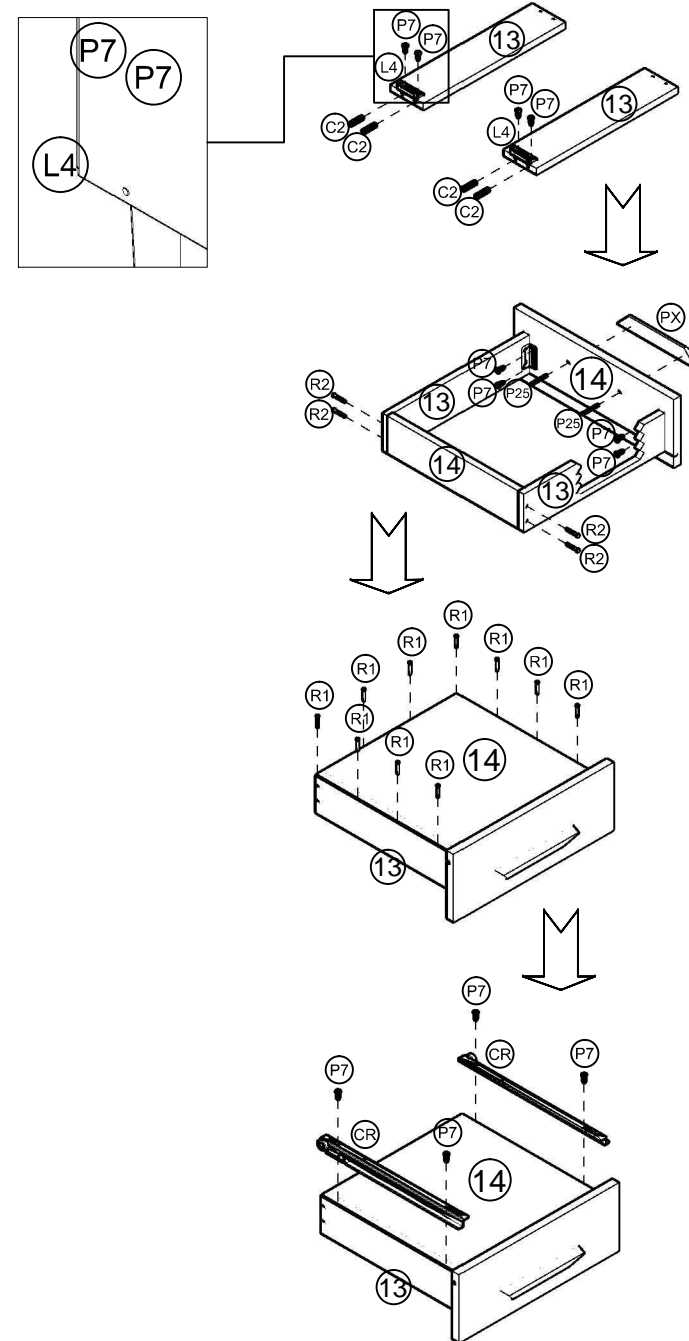

10

COLOQUE A GAVETA
PONGA EL CAJÓN
INSTALL THE DRAWER

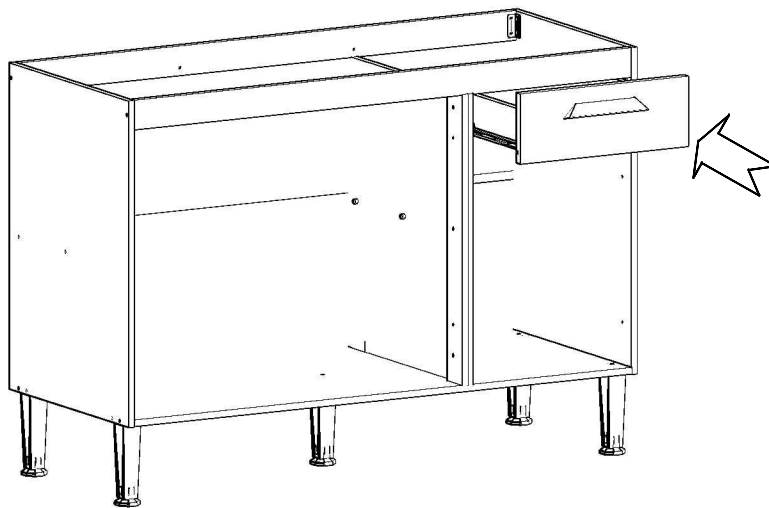

(R1)	(R2)
10X	4X
(PX)	(P25)
1X	2X
(CR)	(L4)
2X	2X
(P7)	(C2)
12X	4X

11

MONTAGEM DAS PORTAS (10 E 11)
 MONTAJE DE LAS PUERTAS (10 Y 11)
 ASSEMBLY OF THE DOORS (10 AND 11)

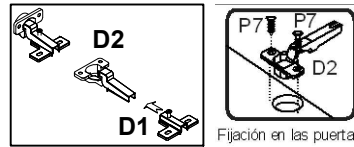
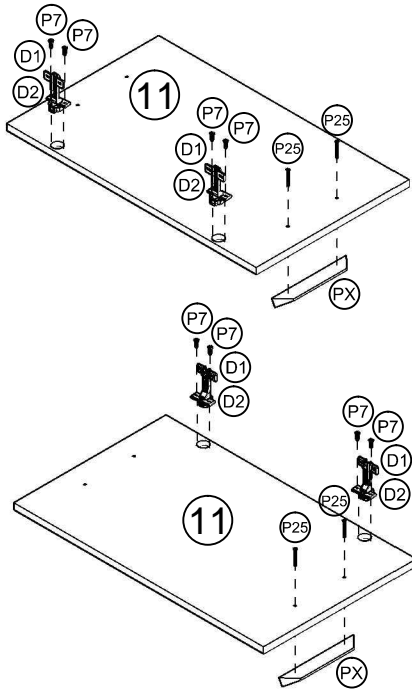

Fijación en las puertas

FIXAÇÃO DA PEÇA "D2" NA PEÇA "D1", PARA DEPOIS FIXAR O CONJUNTO DE DOBRADIÇAS NAS PORTAS (10 E 11)
 FIJACIÓN DE LA PIEZA "D2" EN LA PIEZA "D1", PARA DESPUÉS FIJAR EL CONJUNTO DE LAS BISAGRAS EN LAS PUERTAS (10 Y 11).
 FIXING THE PART "D2" TO THE PART "D1", THEN FIX THE HINGES SET ON THE DOORS (10 AND 11)

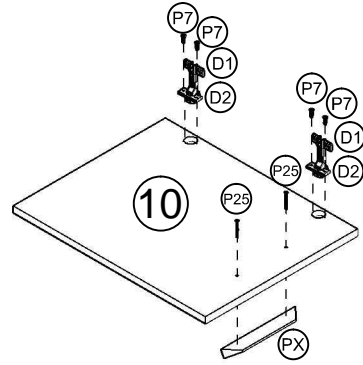

12

COLOQUE AS PORTAS (10 E 11)
 PONGA LAS PUERTAS (10 Y 11)
 INSTALL THE DOORS (10 AND 11)

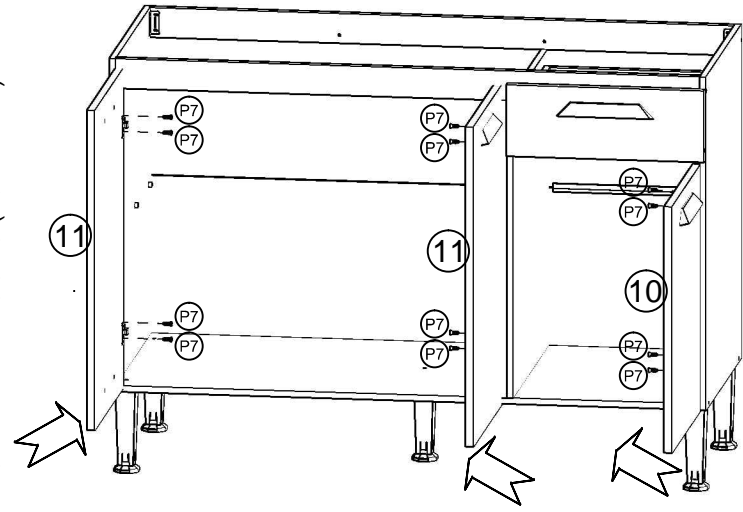

REGULAGEM DAS PORTAS
 AJUSTE DE LAS PUERTAS
 ADJUSTMENT OF THE DOORS

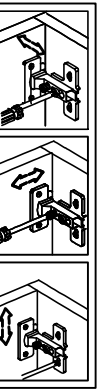

13

PRODUTO PRONTO
 PRODUCTO LISTO
 READY PRODUCT

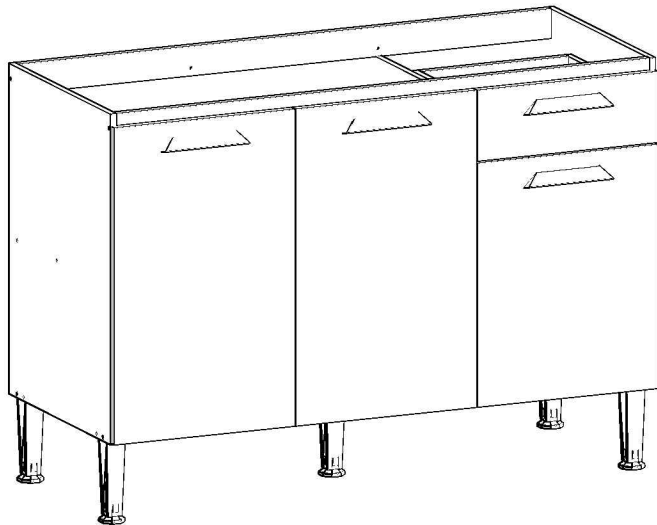

14

PARA REALIZAR A UNIÃO ENTRE DIFERENTES MÓDULOS, FAZER USO DO PARAFUSO "P2"
 PARA HACER LA UNIÓN ENTRE LOS DIFERENTES MÓDULOS, UTILICE LOS TORNILLOS "P2"
 TO JOIN DIFFERENT MODULES, USE THE "P2" SCREW

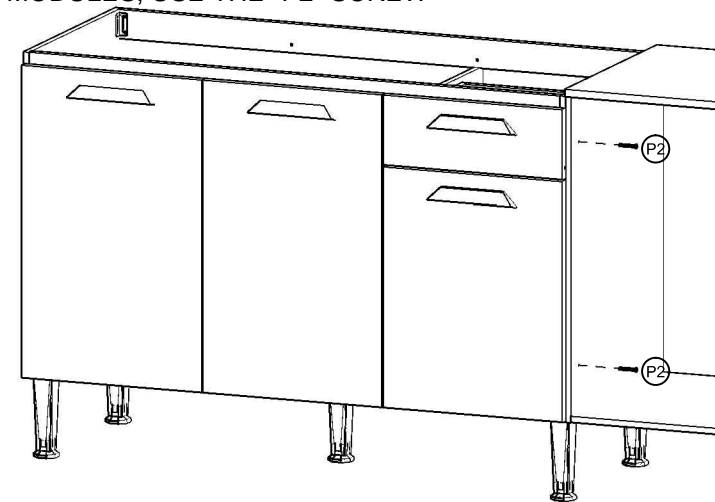

MANUAL DE MONTAGEM / PLANO DE ARMADO

Parabéns! Você comprou um produto de excelente qualidade, fabricado com chapa de madeira de MDP ou MDF, extraída de florestas renováveis. Possui alta resistência e design atual.

Felicitaciones! Usted compró a un producto de excelente calidad, fabricado con placa de madera de MDP o MDF, proveniente de florestas renovables. Tiene alta resistencia y diseño actual.

Antes de montar o móvel, leia com atenção o manual de montagem!
Antes de armar el mueble, lea con atención el manual de ensamble!



ATENÇÃO:
ATENCIÓN:

- 1) Verifique todas as peças antes de começar a montagem.**
 Verifique todas las partes antes de empezar el armado.
- 2) Ao começar a montagem, não apoie as peças na parede.**
 Al empezar el armado, no apoyes las partes en la pared.
- 3) Ao colocar as peças e ferragens de lado, cuidado para não perde-las.**
 Al poner las piezas y herrages a parte, cuidado para no dañarlas.
- 4) O móvel deve ser montado no chão, para isso, use a própria caixa para proteger e não danificar o piso.**
 El mueble suele ser armando al piso, para eso, use la propia caja para protegerlo y no dañar al piso.
- 5) Comece a montagem seguindo as instruções passo a passo.**
 Comience el armado siguiendo la instrucciones paso a paso.
- 6) É de responsabilidade do montador seguir as intruções desse manual, que são fundamentais para a estrutura do móvel.**
 Es de responsabilidad del armador seguir las instrucciones de este manual, que son fundamentales para la estructura del mueble.

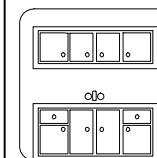

CUIDADOS:
CUIDADOS:

- 1) A conservação e limpeza deve ser feita com um pano levemente umedecido com água.**
 La conservación y limpieza debe ser hecha con un trapo levemente humedecido en agua.
- 2) Não use produtos abrasivos, como saponáceo, detergentes e esponja de aço.**
 No use productos abrasivos, como saponáceo, detergentes y esponja de acero.
- 3) Não use cera ou óleo para dar brilho ao móvel.**
 No use cera o aceites para darle brillo al mueble.
- 4) Não expor o móvel a interperies e nem ao calor excessivo.**
 No exponer el mueble a interperies ni al calor excesivo.
- 5) Ao terminar a montagem, limpe o ambiente e o móvel.**
 Al terminar el armado, limpie al ambiente y al mueble.

FERRAMENTAS:
HERRAMIENTAS:

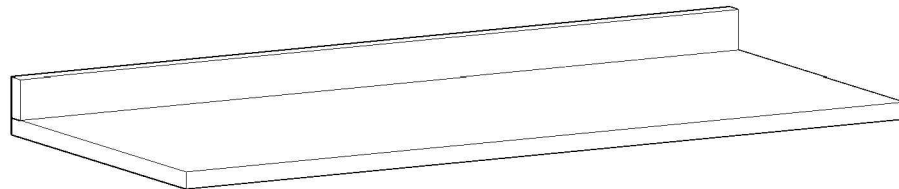

Ref.: 0298

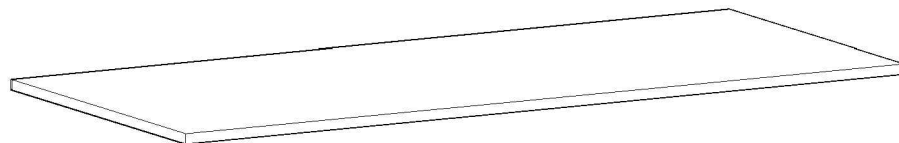

Ref.: 0299

Antes de começar a montagem certifique-se que as caixas estão em perfeitas condições.

Antes de empezar el armado asegúrese que las cajas estén en perfectas condiciones.

Ref.: 0298

LISTA DE PEÇAS / LISTA DE PIEZAS

Nº	Descrição / Descripción	Qtd. Cant.
1	Tampo / Tablero	1
2	Espelho / Espejo	1

LISTA DE FERRAGENS / LISTA DE HERRAJES

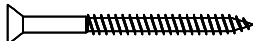
ITEM ITEM	DESCRIÇÃO / DESCRIPCIÓN	QTD. CANT.
P1	 PARAFUSO 4X14 TORNILLO 4X14	16
P16	 PARAFUSO 4X60 TORNILLO 4X60	4
S1	 CHAPA "L" 2 FUROS PLACA "L" 2 AGUJEROS	8

USE A RÉGUA PARA IDENTIFICAR OS PARAFUSOS
UTILICE LA REGLA PARA IDENTIFICAR LOS TORNILLOS

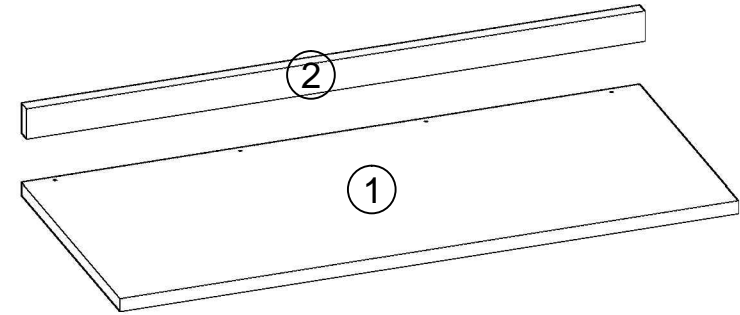
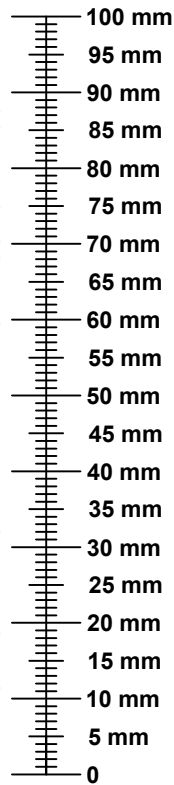

1

FIXE O ESPELHO (2) NO TAMPO (1)
FIJE EL ESPEJO (2) EN EL TABLERO (1)

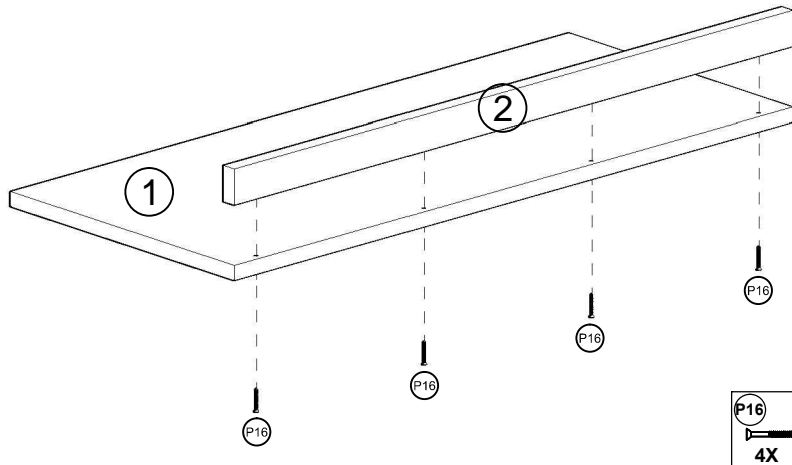

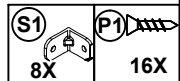
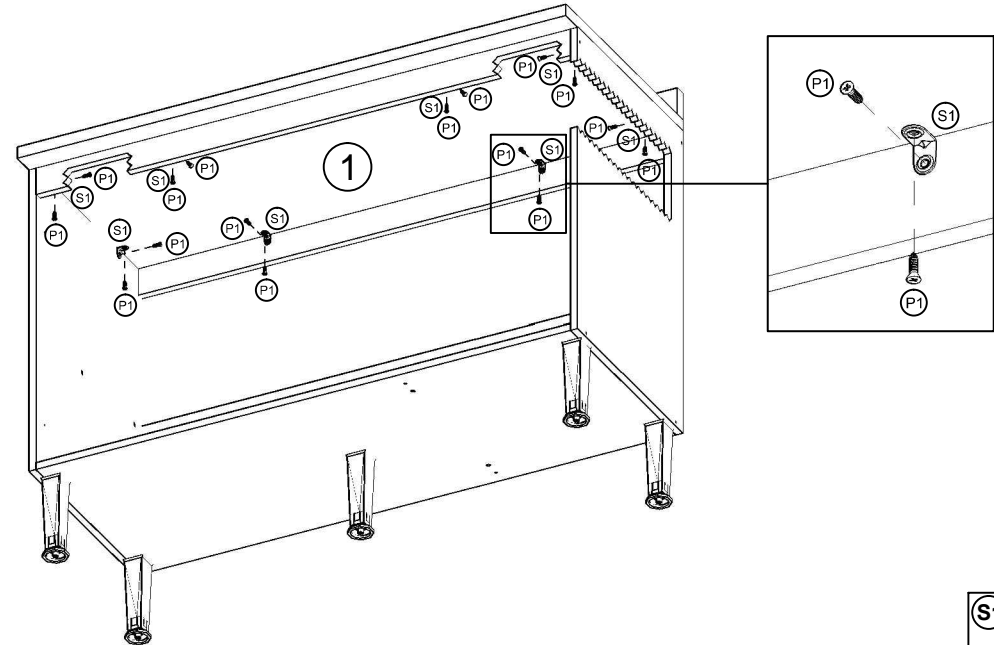

2

FIXE O TAMPO (1) NO BALCÃO
FIJE EL TABLERO (1) EN EL MUEBLE BAJO



Ref.: 0299

LISTA DE PEÇAS / LISTA DE PIEZAS		
Nº	Descrição / Descripción	Qtd. Cant.
1	Tampo / Tablero	1

LISTA DE FERRAGENS / LISTA DE HERRAGES			
ITEM ITEM	DESCRIÇÃO / DESCRIPCIÓN	QTD. CANT.	
P1	 PARAFUSO 4X14 TORNILLO 4X14	16	
S1	 CHAPA "L" 2 FUROS PLACA "L" 2 AGUJEROS	8	

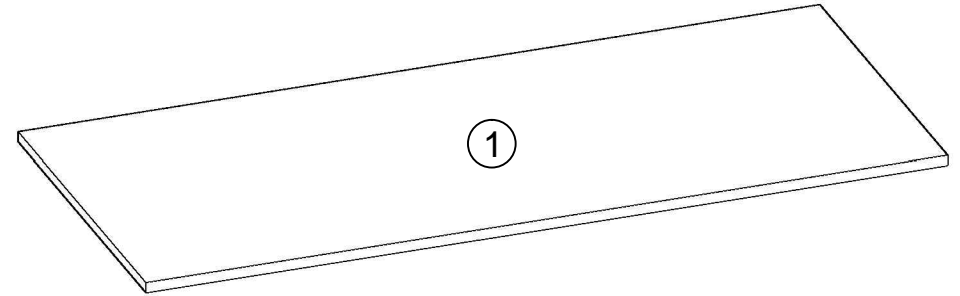
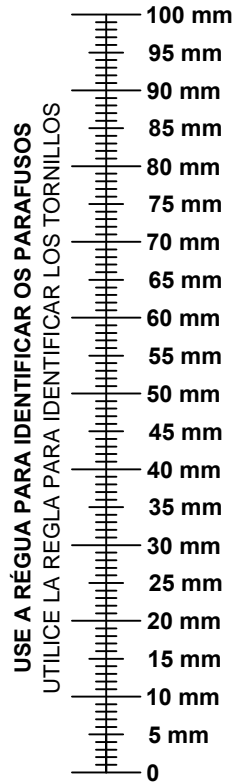

1
FIXE O TAMPO (1) NO BALCÃO
FIJE EL TABLERO (1) EN EL
MUEBLE BAJO

