

**CÓDIGO DE PEÇAS | CODE OF PIECES | CÓDIGO DE PIEZAS**

**VISTA FRONTAL | FRONT VIEW**

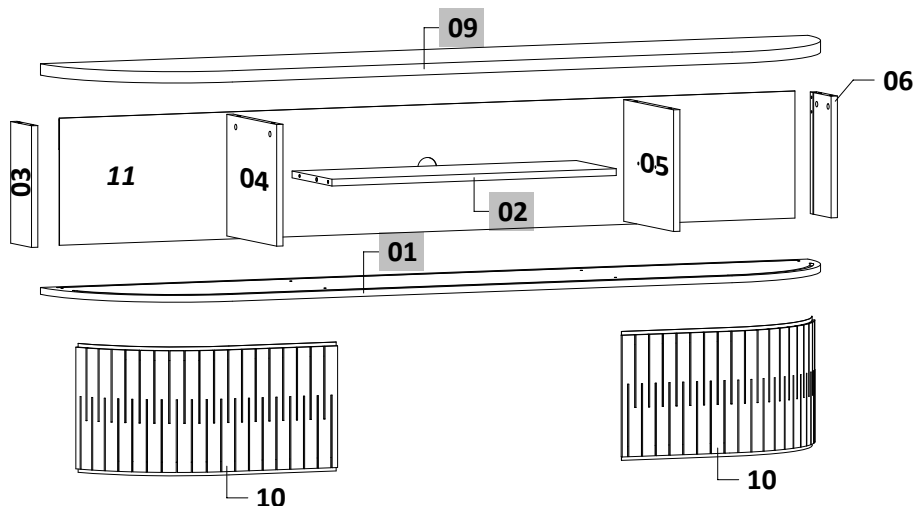

**VISTA TRASEIRA | BACK VIEW / VISTA TRASERA**

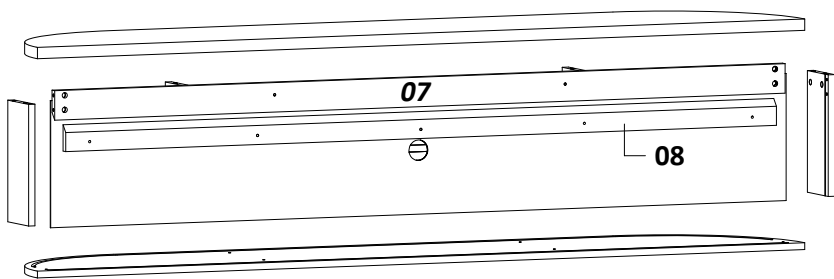

**INSTRUÇÕES DE MONTAGEM | ASSEMBLY INSTRUCTIONS | INSTRUCCIONES DE MONTAJE**

- Prepare a montagem do móvel próximo ao local que ele ficará definitivamente e evite deslocá-lo depois de montado;
  - Forre o chão com papelão ou similar e utilize a isomanta que vem entre as peças para evitar o contato entre elas durante a montagem;
  - Monte o móvel obedecendo a ordem numérica da **sequência de montagem (S.M.)**, identificando as peças pelo **código de peça (C.P.)** carimbado na mesma, de acordo com a tabela.
- Prepare the assembly of the close piece of furniture to the place that it will be definitively and avoid to move after done. Will be definitively and avoid to move after done;
  - Cover the ground with cardboard or similar and use the isomanta that it comes among the pieces to avoid the contact among them during the assembly;
  - Set up the piece of furniture obeying the numeric order of the **assembly sequence (S.M.)**, identifying the pieces by **code of piece (C.P.)** stamped in the same, in agreement with the table.
- Prepare la montaje del mobiliario proximo al lugar que estará definitivamente y evite mover después de hecho;
  - Tape la suelo con cartón o similar y use la "isomanta" que viene entre las piezas para evitar el contacto entre ellos durante la montaje;
  - Monte el mobiliario obedeciendo el orden numérico de la **sucesión de montaje (S.M.)**, identificando las piezas por el **código de piezas (C.P.)** de la misma estampado en esta, de acuerdo con la tabla.

**Ferramentas necessárias para montagem (não fornecidas)**  
Tools required for assembly (not supplied)  
Herramientas necesarias para el montaje (no suministradas)



**Pessoas necessárias para montagem**  
People needed for assembly  
Personas necesarias para el montaje

**Tempo Montagem**  
Assembly time  
Tiempo montaje

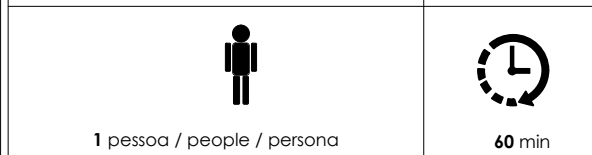

**CUIDADOS ESPECIAIS | SPECIAL CARES | CUIDADOS ESPECIALES:**

**LIMPEZA:** Pano limpo umedecido em água e sabão neutro - **BRILHO:** Flanela seca  
**CLEANING:** Clean cloth humidified in water and neutral soap - **SHINE:** Dry flannel  
**LIMPIEZA:** Tela limpia humedecida en la agua y el jabón neutro - **BRILLO:** Flanela seca

**ASPECTO FINAL | FINAL ASPECT**

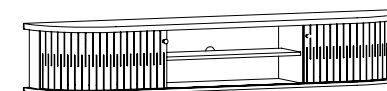

→1,830 m ↑ 0,310 m ↯ 0,330 m  
**Dimensão do Produto:**  
Product dimensions:  
Dimensiones del producto:

**PESO SUPORTADO**  
**WEIGHT SUPPORTED**  
**PESO SOPORTADO**

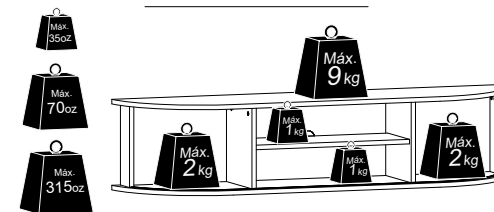

REF.:	CÓDIGO DA PEÇA   CODE PIECE   CÓDIGO DE PIEZA						DESCRIÇÃO DA PEÇA PART DESCRIPTION DESCRIPCIÓN DE PIEZA	MATÉRIA PRIMA FEEDSTOCK	DIMENSÕES DIMENSIONS DIMENSIONES	QUANT. AMOUNT CANTIDAD
	NATURALE OFF WHITE	FENDI NATURALE	IMPERIAL SÉPIA	CALACATA OFF WHITE	JADE OLIVA	CINAMOMO OFF WHITE				
01	203793.027	203793.029	203793.032	203793.033	203793.035	203793.037	Base   Base   Base	MDP	1,830 x 0,326 x 0,015	1
02	203794.027	203794.029	203794.034	203794.026	203794.036	203794.037	Prateleira   Shelf   Estante	MDP	0,678 x 0,224 x 0,015	1
03	203795.027	203795.029	203795.034	203795.026	203795.036	203795.037	Lateral esquerda   Left side   Lateral izquierdo	MDP	0,268 x 0,117 x 0,015	1
04	203796.027	203796.029	203796.034	203796.026	203796.036	203796.037	Divisão esquerda   Left split   División izquierda	MDP	0,280 x 0,268 x 0,015	1
05	203797.027	203797.029	203797.034	203797.026	203797.036	203797.037	Divisão direita   Right split   División derecha	MDP	0,280 x 0,268 x 0,015	1
06	203798.027	203798.029	203798.034	203798.026	203798.036	203798.037	Lateral direita   Right side   Lateral derecho	MDP	0,268 x 0,117 x 0,015	1
07	203799.009	203799.009	203799.009	203799.009	203799.009	203799.009	Apoio da bancada   Caucus support   Apoyo del caucus	MDP	1,742 x 0,065 x 0,015	1
08	203800.009	203800.009	203800.009	203800.009	203800.009	203800.009	Apoio da parede   Wall support   Soporte de pared	MDP	1,695 x 0,058 x 0,015	1
09	203801.027	203801.029	203801.032	203801.033	203801.035	203801.037	Tampo   Top   Tampo	MDF	1,830 x 0,326 x 0,025	1
10	203802.026	203802.027	203802.034	203802.026	203802.036	203802.026	Porta deslizante   Sliding door   Puerta deslizante	MDF	0,617 x 0,258 x 0,006	2
11	203803.027	203803.029	203803.034	203803.026	203803.036	203803.037	Fundo   Bottom   Fondo	MDF	1,754 x 0,280 x 0,003	1

### LEGENDA DAS CORES | COLOR LEGEND | LEYENDA DE COLOR

**009 - SEM PINTURA** | UNPAINTED | SIN PINTAR

**026 - OFF WHITE**

**027 - NATURALE**

**029 - FENDI**

**032 - IMPERIAL**

**033 - CALACATA**

**034 - SÉPIA**

**035 - JADE**

**036 - OLIVA**

**037 - CINAMOMO**

# ACESSÓRIOS | ACCESSORIES | ACCESORIOS

## PARAFUSOS | Screw | Tornillo



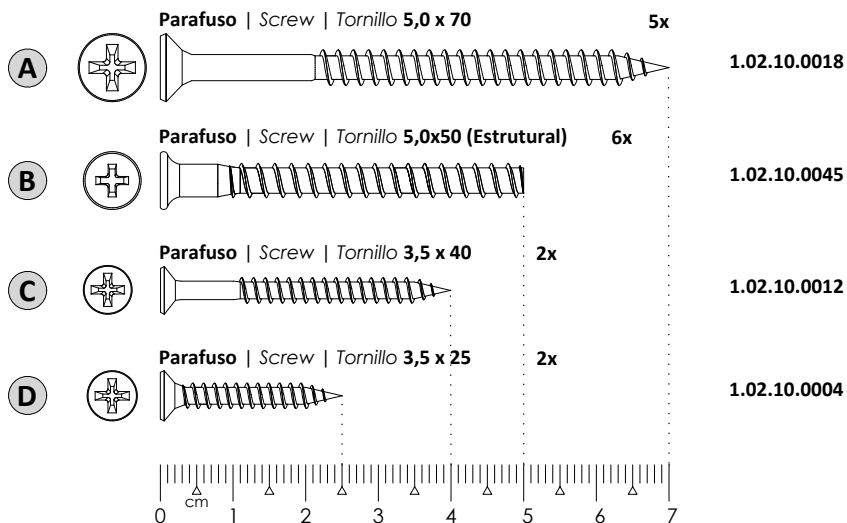

## CÓDIGO | CODE

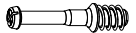

### RELAÇÃO DE COR DOS ACESSÓRIOS

Color ratio of accessories | Relación de color de los accesorios

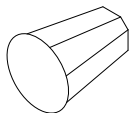
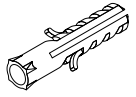
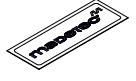
LETRA LETTER	DESCRIÇÃO DESCRIPTION DESCRIPCIÓN	MATÉRIA PRIMA FEEDSTOCK	COR COLOR	QUANT.   AMOUNT   CANTIDAD						CÓDIGO CODE
				NATURALE OFF WHITE	FENDI NATURALE	IMPERIAL SÉPIA	CALACATA OFF WHITE	JADE OLIVA	CINAMOMO OFF WHITE	
<b>N</b>	Tapa furo adesivo 18mm Adhesive hole cover 18mm Tapa agujero adhesivo 18mm	Papel Paper	Off White				6			1.02.08.0216
			Naturale	6						1.02.08.0219
			Sépia		6					1.02.08.0258
			Fendi		6					1.02.08.0245
			Oliva				6			1.02.08.0267
			Cinamomo							1.02.08.0286
<b>O</b>	Giz p/ correção Touch-up chalk Tiza correctora	Cera Wax	Calacata / Off White	1			1	1	1.02.14.0008	
			Naturale	1	1				1.02.14.0009	
			Imperial / Sépia			1			1.02.14.0018	
			Fendi		1				1.02.14.0011	
			Jade / Oliva				1		1.02.14.0021	
			Cinamomo					1	1.02.14.0023	
<b>P</b>	Trilho flexível 4/8 1915mm Flexible rail 4/8 1915 mm Carril flexible 4/8 1915mm	Plástico Plastic	Fendi		1				1.02.07.0641	
			Off White				1		1.02.07.0640	
			Naturale	1					1.02.07.0634	
			Jade / Oliva				1		1.02.07.0639	
			Imperial			1			1.02.07.0638	
			Cinamomo					1	1.02.07.0647	

LETRA LETTER	DESCRIÇÃO DESCRIPTION DESCRIPCIÓN	MATÉRIA PRIMA FEEDSTOCK	QUANTIDADE AMOUNT CANTIDAD	CÓDIGO CODE
<b>E</b>	 Pino girofix 5,0x30mm Girofix pin 5,0x30mm Pino girofix 5,0x30mm	Metal	12	1.02.05.0007
<b>F</b>	 Cavilha 6x30mm Dowel 6x30mm Clavija 6x30mm	Madeira Wood Madera	12	1.02.05.0001
<b>G</b>	 Castanha girofix 12x10mm Girofix chestnut 12x10mm Castaña girofix 12x10mm	Metal	12	1.02.05.0006
<b>H</b>	 Puxador diamante Diamond handle Tirador de diamante	Plástico Plastic	2	1.02.02.0047
<b>i</b>	 Bucha para parede 8mm Bucha for wall 8mm Buja para pared 8mm	Plástico Plastic	5	1.02.06.0079
<b>J</b>	 Etiqueta resinada Resin label Etiqueta en resina	Plástico Plastic	1	1.02.08.0013
<b>N</b>	 Sache de Silicone 10g Silicone sachet 0,42oz Bolsita de silicone 0,42oz	Silicone Silicona	1	1.02.05.0047

**1º PASSO | PASS | PASO**

PEÇAS  
PIECES  
PIEZAS

S.M.	C.P.
01	04
02	02
03	05

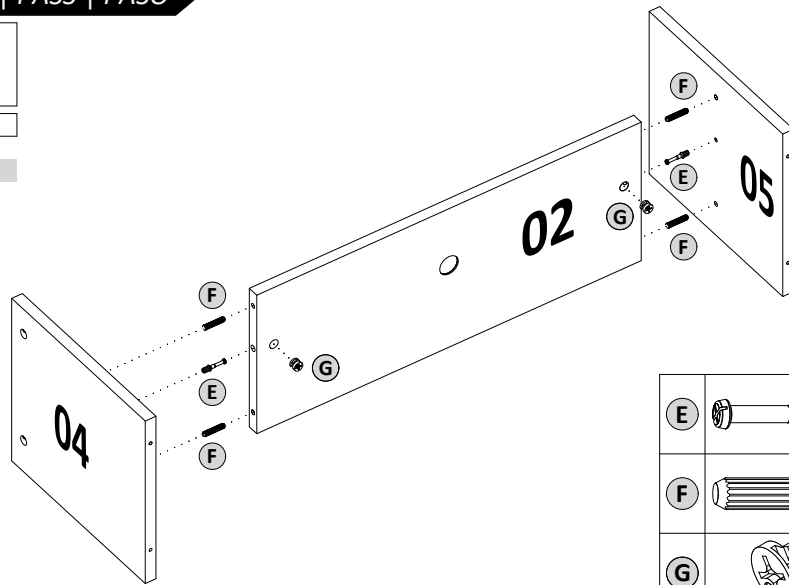

E		2
F		4
G		2

**2º PASSO | PASS | PASO**

PEÇAS  
PIECES  
PIEZAS

S.M.	C.P.
01	01

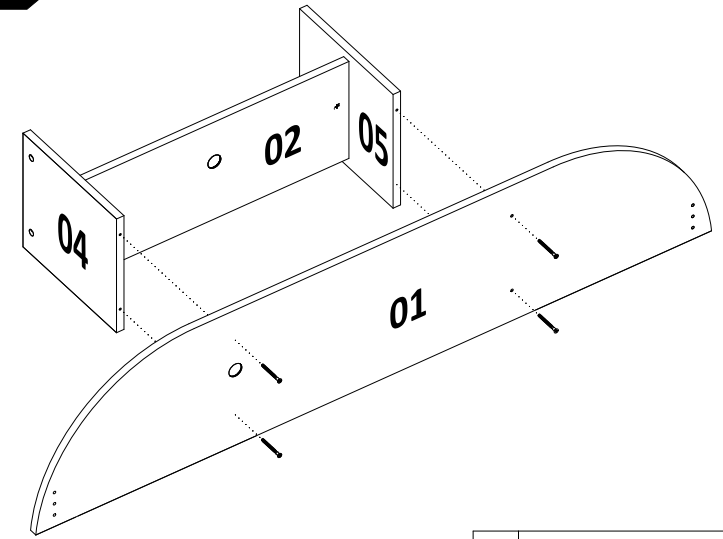

B		3
---	--	---

**3º PASSO | PASS | PASO**

PEÇAS  
PIECES  
PIEZAS

S.M.	C.P.
01	01
02	06
03	03
04	07
05	11

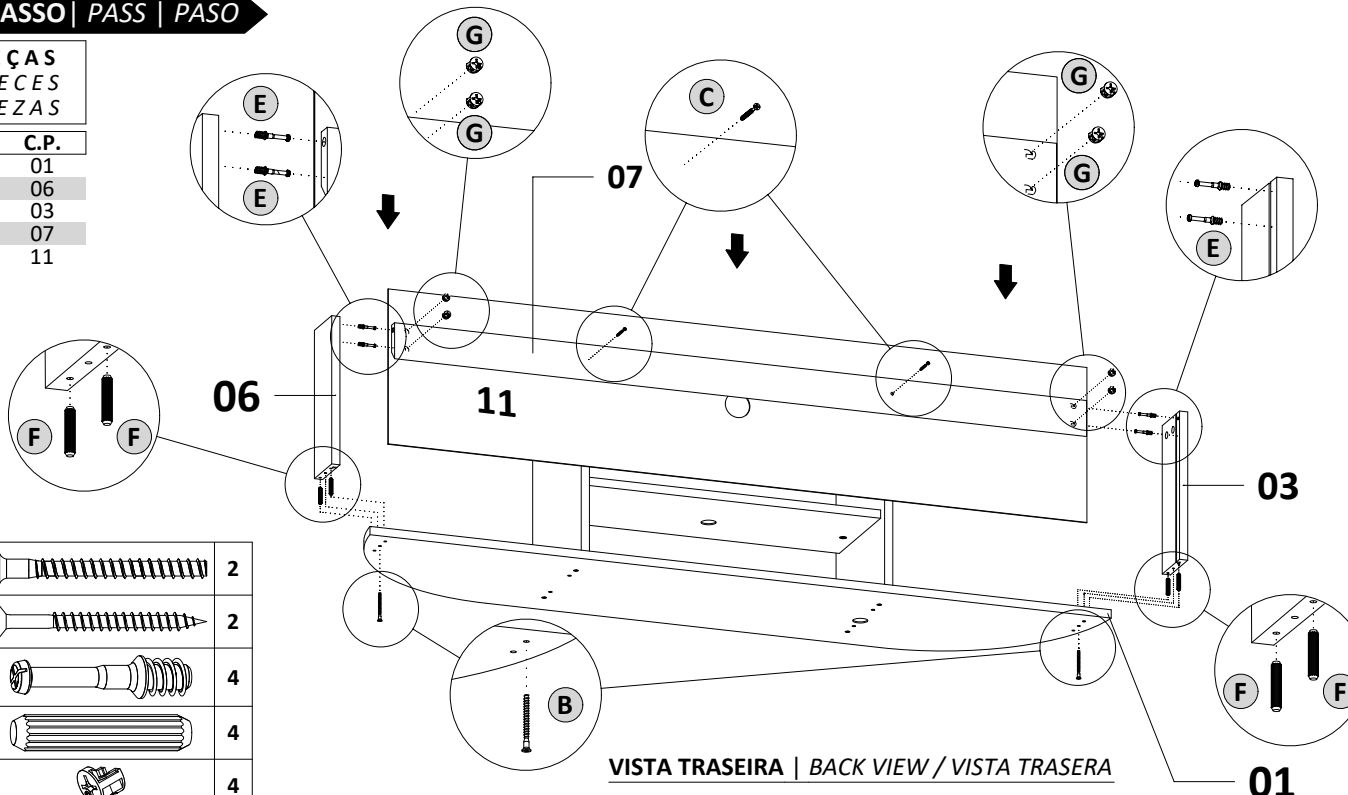

B		2
C		2
E		4
F		4
G		4

VISTA TRASEIRA | BACK VIEW / VISTA TRASERA

**4º PASSO | PASS | PASO**

PEÇAS  
PIECES  
PIEZAS

S.M.	C.P.
01	09

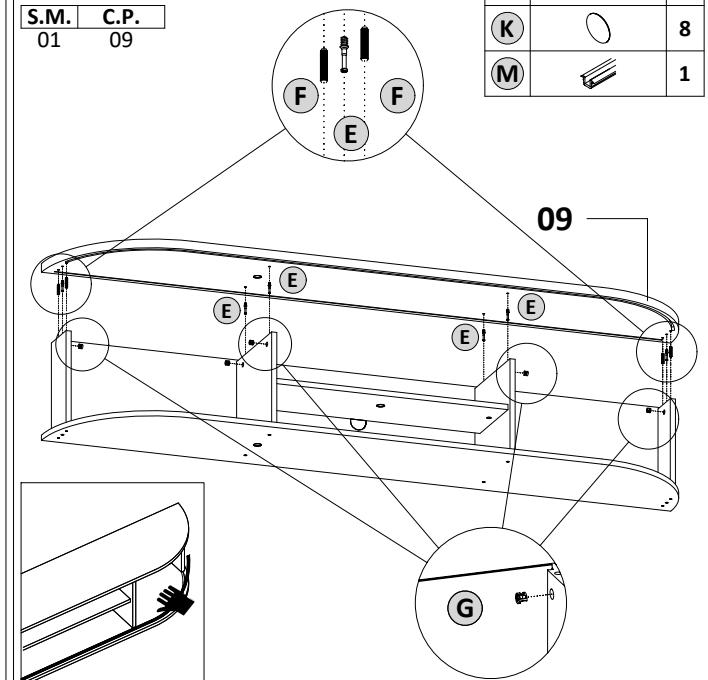



E		8
F		4
G		8
K		8
M		1

**5º PASSO | PASS | PASO**

PEÇAS  
PIECES  
PIEZAS

S.M.	C.P.
01	10
02	10

(A)		2
(M)		2

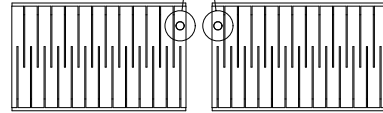
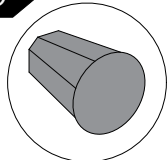

Porta esquerda  
Door left  
Puerta Izquierda

Porta direita  
Door right  
Puerta derecha

**NÃO** devem ser montado as portas conforme imagens abaixo

The doors should NOT be mounted as shown below:

Las puertas NO deben montarse como se muestra a continuación:

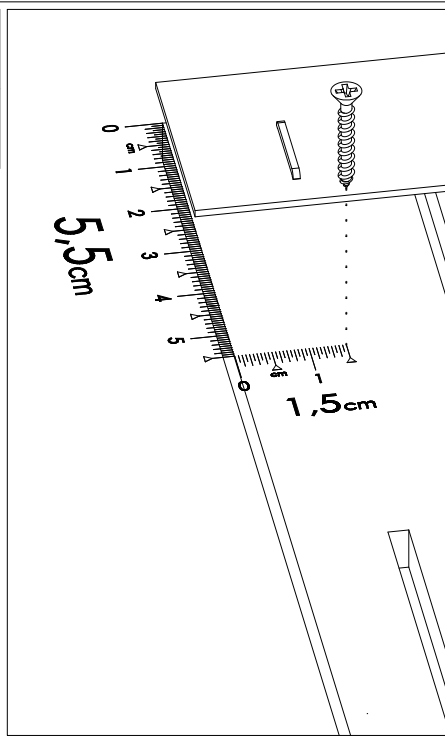
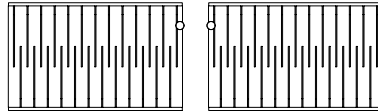

**6º PASSO | PASS | PASO**

**Encaixando a parte superior da porta no canal superior**  
Snapping the top of the port in the top channel  
Rompiendo la parte superior del puerto en el canal superior

Soltar os pinos girofix para encaixar as portas conforme imagem  
Release the girofix pins to fit the doors as shown in the image  
Suelte los pasadores girofix para que se ajusten a las puertas como se muestra en la imagen

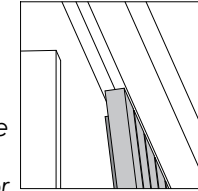

Soltar os pinos girofix para encaixar as portas conforme imagem  
Release the girofix pins to fit the doors as shown in the image  
Suelte los pasadores girofix para que se ajusten a las puertas como se muestra en la imagen

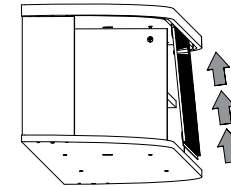

PORTA / DOOR / PUERTA

**Encaixando a parte inferior da porta no canal do trilho**  
Snapping the bottom of the door on the rail channel  
Rompiendo la parte inferior de la puerta en el canal ferroviario

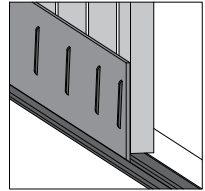
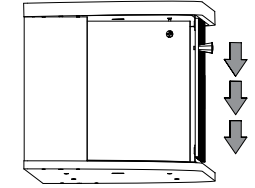



PORTA / DOOR / PUERTA

**7º PASSO | PASS | PASO**

PEÇAS  
PIECES  
PIEZAS

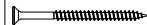
S.M.	C.P.
01	08

(A)		5
(i)		5

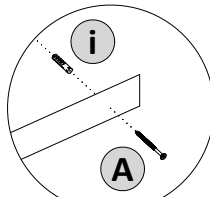

(N)	SILICONE	1
-----	----------	---

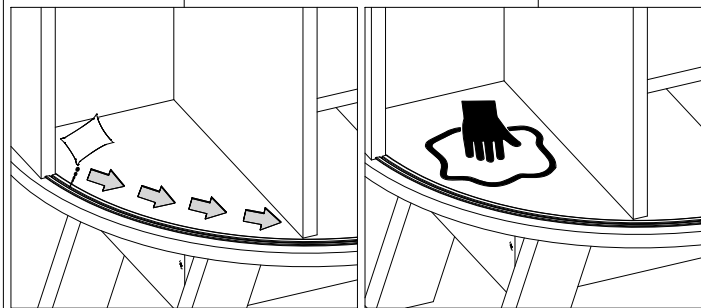
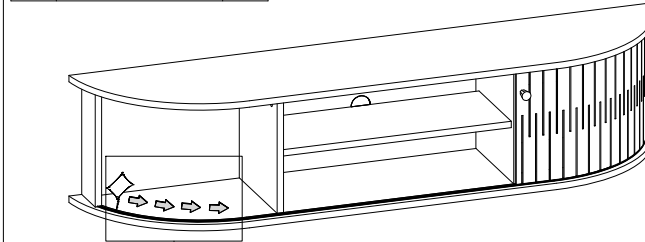

Parede | Wall | Pared

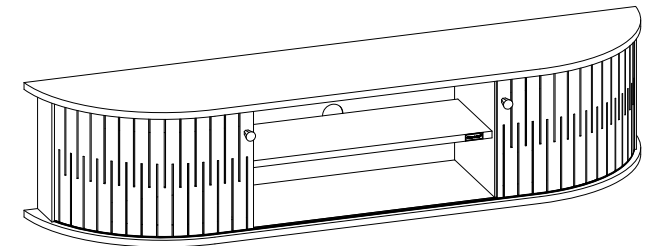

Medida do piso até o furo da parede  
Measure from floor to wall hole  
Mida desde el suelo hasta el agujero de la pared.

Parede | Wall | Pared  
08

