

Capacidade de Carga - Load Capacity - Capacidad de carga

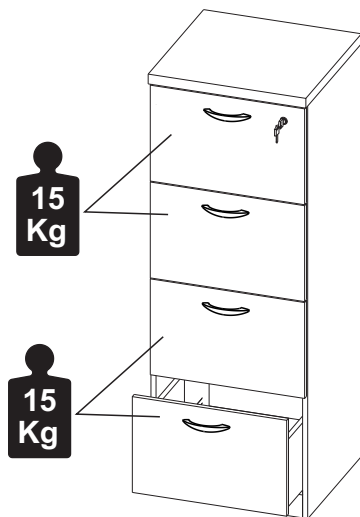

Manutenção e Limpeza

Vidros: pano levemente umedecido com álcool, seguido de pano seco.
Madeiras: pano levemente umedecido com água, seguido de pano seco.
*Nunca utilizar produtos químicos ou abrasivos.

Maintenance and Cleaning

Glasses: cloth lightly moistened with alcohol, followed by dry cloth.
Woods: cloth slightly moistened with water, followed by cloth se.
*Never use chemicals or abrasives.

Mantenimiento y Limpieza

Vidrios: legeramente humedecido con alcohol, seguido de un paño seco.
Madera: ligeramente humedecido con agua, seguido de un paño seco.
*No utilice nunca productos químicos o abrasivos.

INSTRUÇÕES DE MONTAGEM ASSEMBLY INSTRUCTIONS INSTRUCCIONES DE MONTAJE

GAVETEIRO DRAWERS CAJONERO

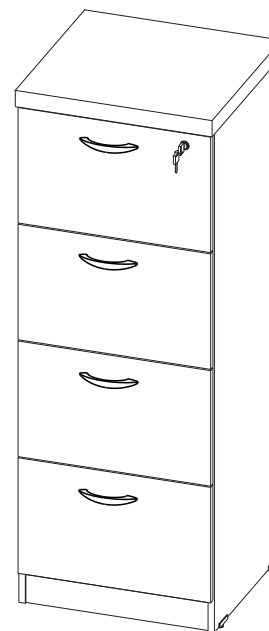

REF. # 4613



LISTA DE PEÇAS

LISTA DE PEÇAS

- 01 - Lateral Esquerda
- 02 - Lateral Direita
- 03 - Tampo
- 04 - Base
- 06 - Frente Gaveta Tranca
- 07 - Frente Gav. Maior
- 09 - Rodapé
- 11 - Fundo Gaveta
- 12 - Lateral Esq. Gav. Maior
- 13 - Lateral Dir. Gav. Maior
- 14 - Costa Gav. Maior
- 15 - Costa

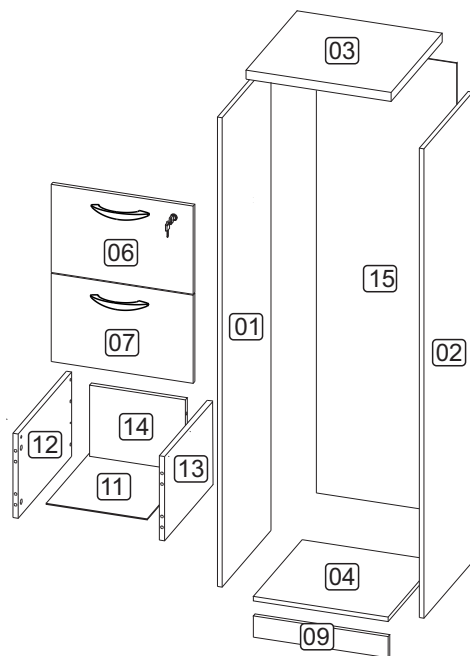

LISTA DE PIEZAS

- 01 - Lateral Izquierda
- 02 - Lateral Derecha
- 03 - Tampo
- 04 - Base
- 06 - Frente Cajón tranca
- 07 - Frente Cajón Mayor
- 09 - Pie
- 11 - Fondo Cajón
- 12 - Lateral Izquierda Cajón mayor
- 13 - Lateral Derecha Cajón Menor
- 14 - Revés Cajón Mayor
- 15 - Costa

PARTS IDENTIFICATION

- 01 - Left Side
- 02 - Right Side
- 03 - Cover
- 04 - Base
- 06 - Front Drawer Locks
- 07 - Large Front Drawer
- 09 - Footer
- 11 - Bottom Drawer
- 12 - Large Left Side Drawer
- 13 - Large Right Side Drawer
- 14 - Large Back Drawer
- 15 - Coast

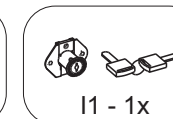
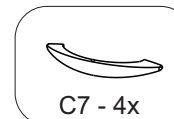
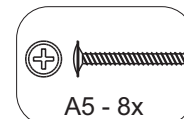
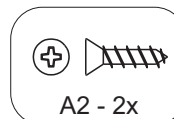
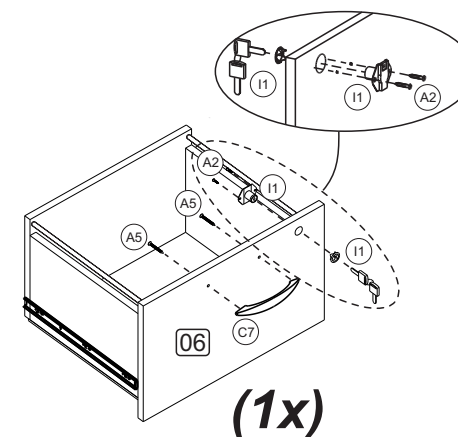
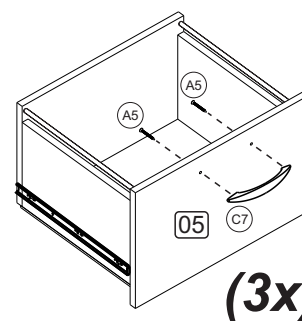
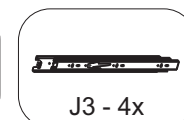
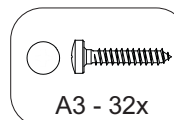
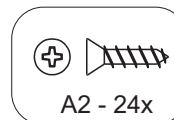
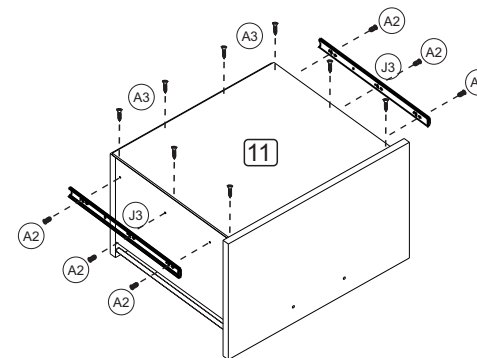

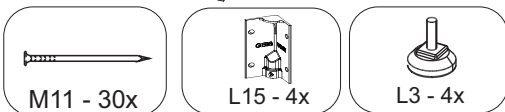
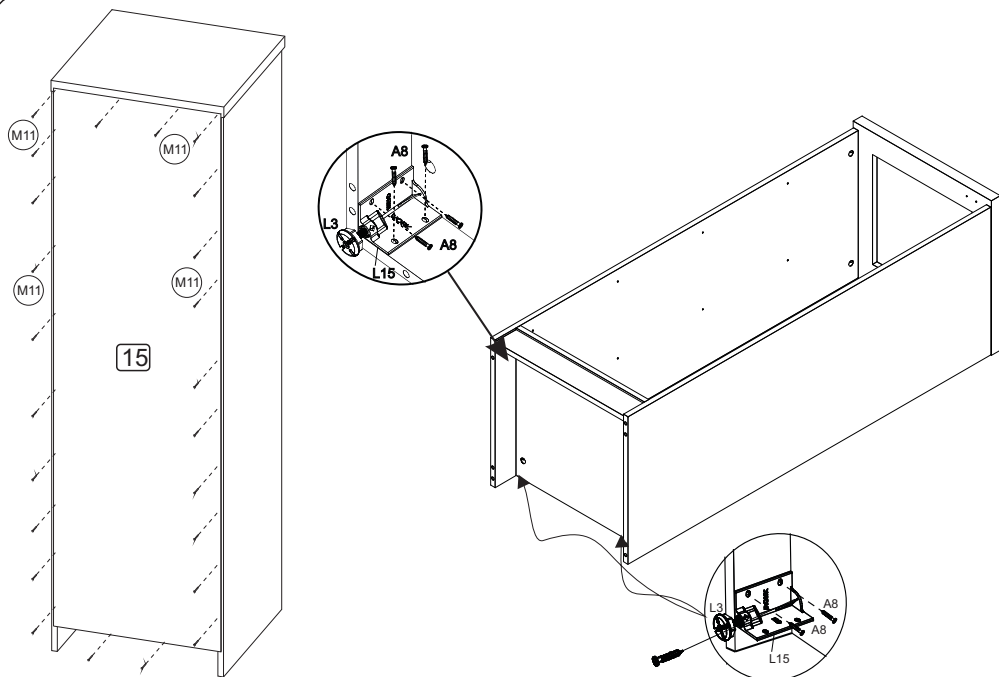

Fixe o parafuso A8 na parte superior da cantoneira L15.

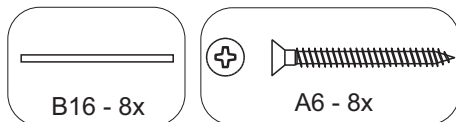
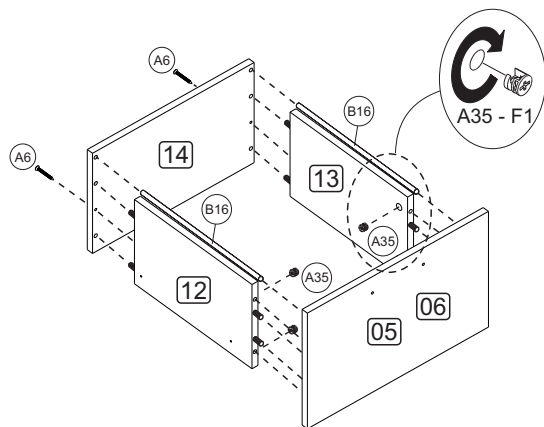

ACESSÓRIOS ACCESSORIES ACCESORIOS

A2 - PARAF. 3,5x14 CC
52x



A3 - PARAF. 3,5x20 CP
32x



A5 - PARAF. 3,5x25 CF
8x



A6 - PARAF. 3,5x40 CC
8x



A32 - PARAF. MINIFIX
24x

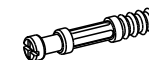

A35 - TAMBOR MINIFIX
24x



B16 - HASTE MET.
353mm **8x**



C7 - PUXADOR
4x



D1 - CAVILHA 8x30
44x

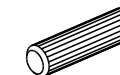

F1 - TAPA FURO \varnothing 18
16x



I1 - FECHADURA P/GAV.
1x



J3 - TRILHO TELESC.
350mm **4x**



L3 - SAPATA PLAST.1/4
4x



L15 - CANTONEIRA P/
SAPATA 70X40X40 **4x**







M2 - CHAPA L 2 FUROS
OBL 42x17x0,9mm ZB **1x**

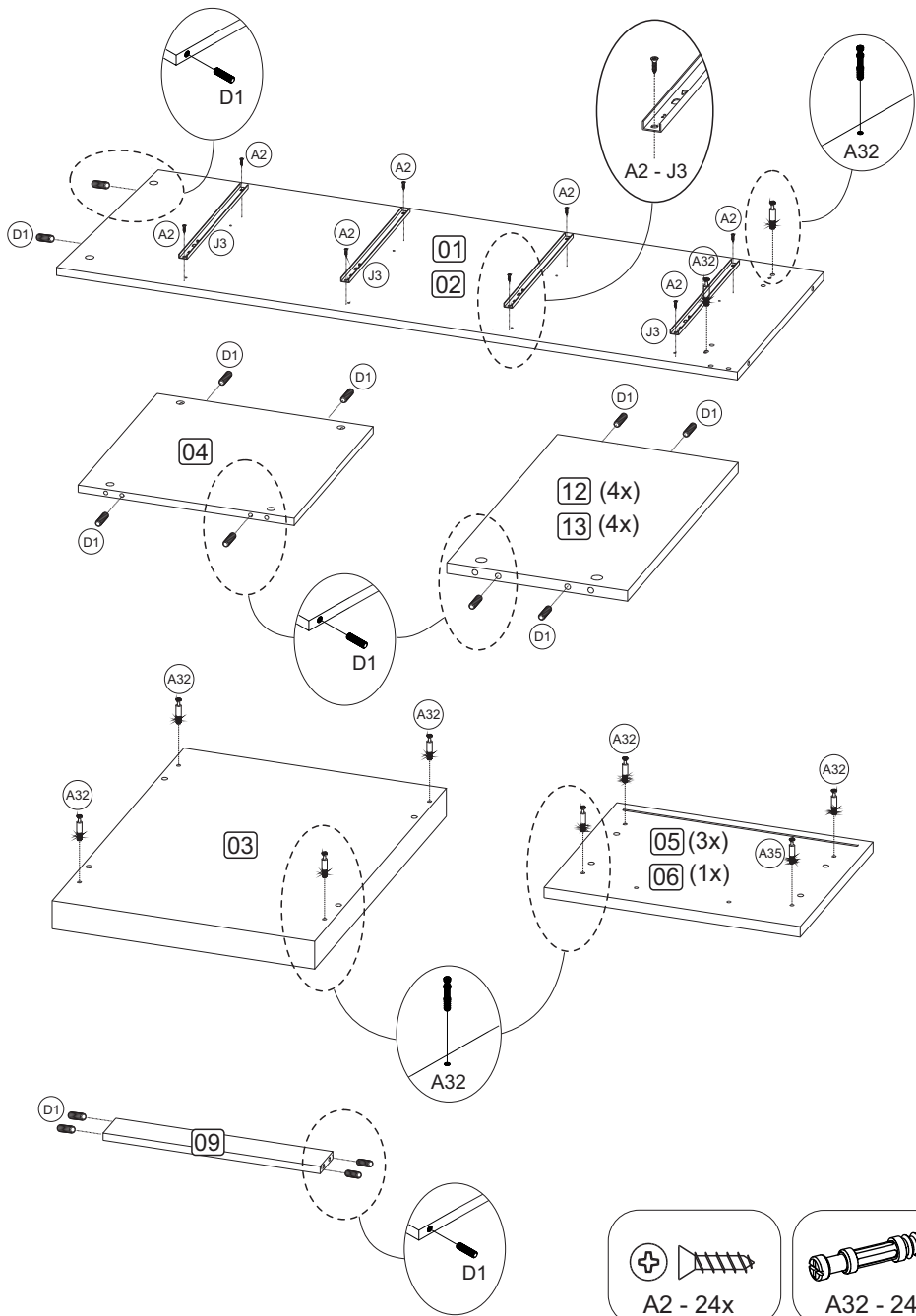

M11 - PREGO 10x10
30x



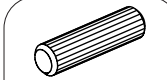



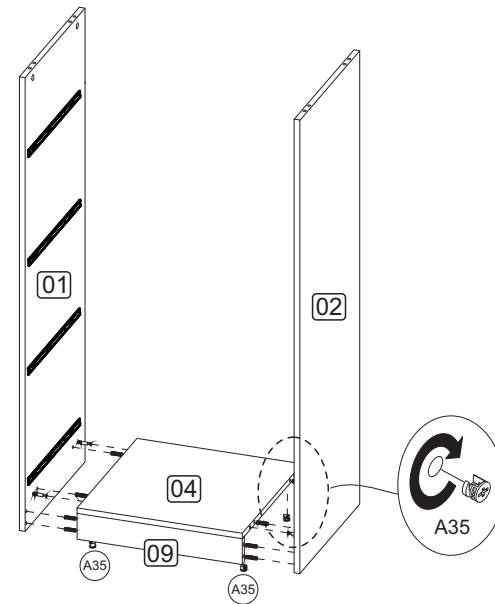

-  A2 - 24x
-  A32 - 24x
-  D1 - 44x
-  J3 - 4x

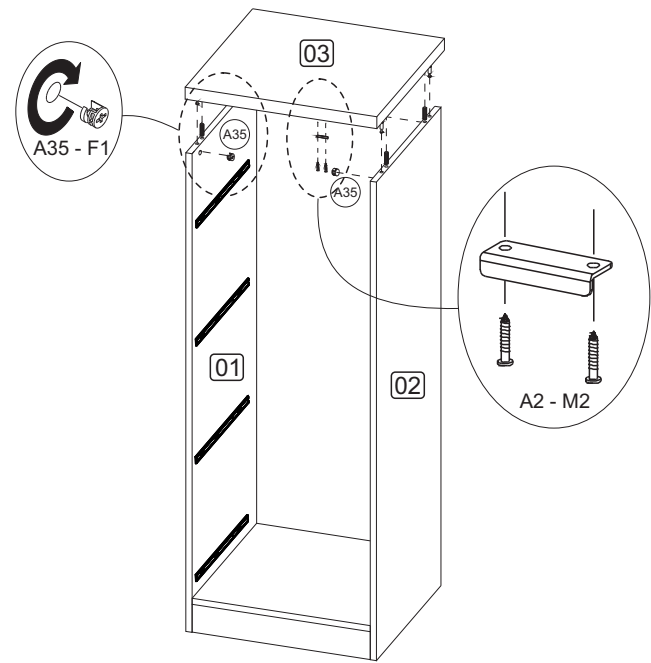

-  A35 - 4x

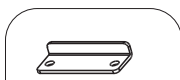

-  A2 - 2x
-  A35 - 4x
-  F1 - 4x
-  M2 - 1x