

Item	Caixa Caja Box	Qtd Ctd Qty	Descrição   Descripción   Description	Medidas (mm)   Dimensions (mm)   Size (measurements) (mm)
01	2/3	01	Rodapé frontal   Rodapié frontal   Front footboards	2136x120x12
02	1/3	03	Travessa Rodapé   Rodapié Bandeja   Footboard Platter	415x120x12
03	2/3	01	Rodapé traseiro   Rodapié trasero   Rear footboard	2136x120x12
04	2/3	01	Lateral esquerda   Lateral izquierda   Left side	2100x445x12
05	2/3	01	Base   Base   Base	2136x445x12
06	1/3	01	Divisão esquerda   División izquierda   Left division	1880x445x12
07=13	1/3	01	Prateleira   Estante   Shelf	525x350x12
08	1/3	01	Divisão das Gavetas   División de cajones   Division of Drawers	720x445x12
09	1/3	01	Tampo das gavetas   Tapa del cajón   Drawer top	1062x445x12
10	2/3	01	Pilastra   Pilastra   Pillar	1148x95x12
11	1/3	02	Prateleira Maior   Estante Más Grande   Larger Shelf	1062x350x12
12	1/3	01	Divisão direita   División derecha   Right division	1880x445x12
13=07	1/3	01	Prateleira   Estante   Shelf	525x350x12
14	2/3	01	Tampo Superior   Cubierta Superior   Top Cover	2136x445x12
15	2/3	01	Lateral direita   Lateral derecha   Right side	2100x445x12
16	2/3	04	Fundo   Fondo   Raw	1904x537x3
17	2/3	01	Chapéu   Sombrero   Hat	2158x80x15
18	3/3	08	Porta   Puerta   Central	1889x265x15
19	1/3	04	Frente de Gaveta   Frente del Cajón   Drawer Front	467x190x12
20	1/3	08	Lado de gaveta   Lado del cajón   Drawer side	350x100x12
21	1/3	04	Ripa de trás   Listón trasero   Rear batten	450x100x12
22	2/3	04	Fundo de Gaveta Recortado   Fondo de cajón recortado   Cropped Drawer Background	449x367x3



Ind. e Com. de Móveis Henn  
Mondai - SC - Brasil

+55 49 3674.3500

@moveishenn  
www.henn.com.br

INSTRUÇÕES DE MONTAGEM

INSTRUCCIONES DE MONTAJE  
ASSEMBLY INSTRUCTIONS

Roupeiro 08 Portas / Armario de 08 Puertas / 08 Door Wardrobe

- B51-127 Nature/Off White
- B51-130 Castanho HP II

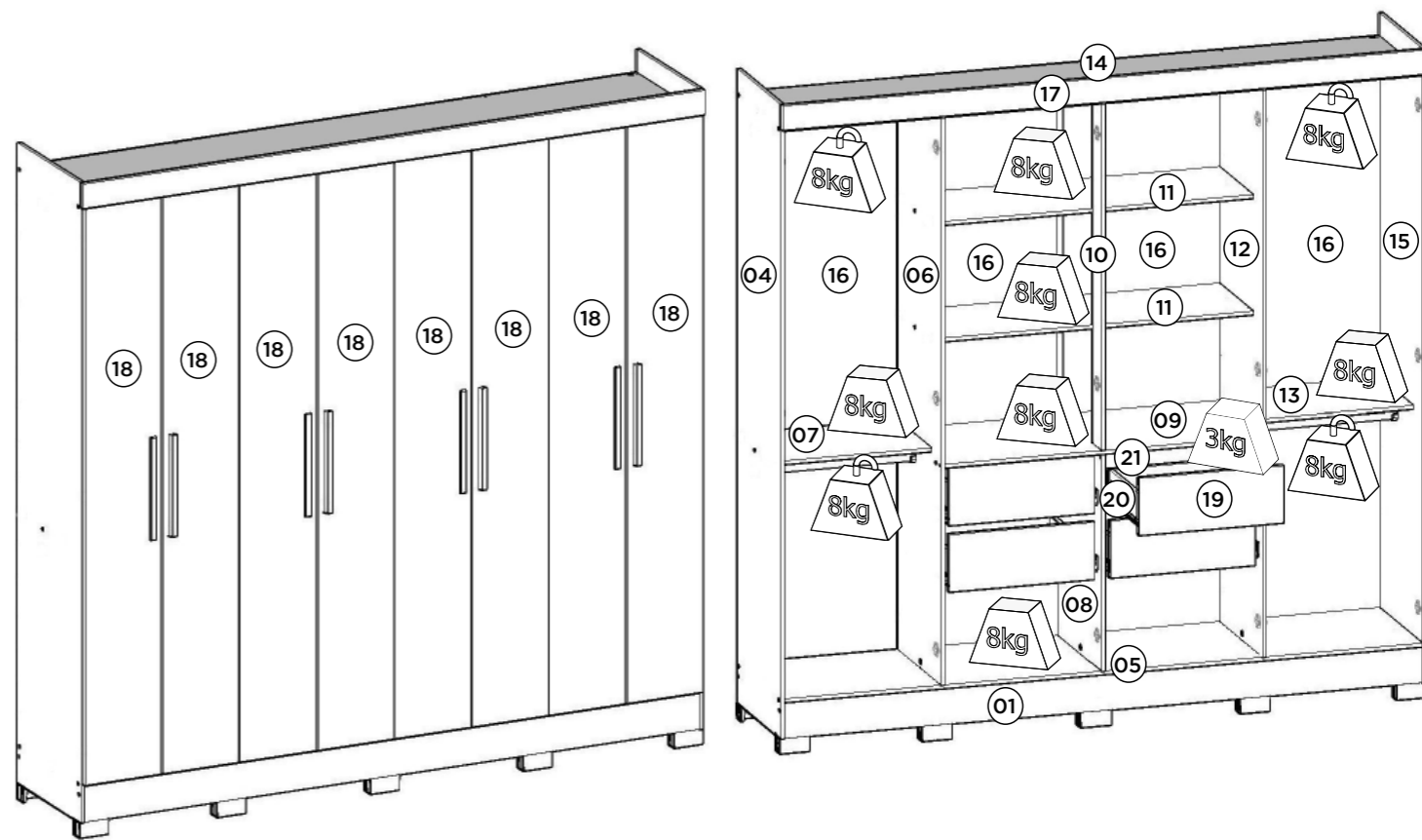

FERRAGENS | HERRAJES | HARDWARE

<b>A</b> 12x  Parafuso 4,5x50mm CHT. Tornillo 4,5x50mm CHT. Screw 4,5x50mm CHT.	<b>B</b> 18x  Parafuso 4,0x22mm MET. FLA. Tornillo 4,0x22mm MET.FLA. Screw 4,0x22mm MET.FLA.	<b>C</b> 17x  Parafuso 3,5x40mm CHT. Tornillo 3,5x40mm CHT. Screw 3,5x40mm CHT.	<b>D</b> 16x  Parafuso 3,5x25mm FLA. Tornillo 3,5x25mm FLA. Screw 3,5x25mm FLA.	<b>E</b> 01x  Etiqueta resinada Briz Etiqueta resinada Briz Briz resin label
<b>F</b> 174x  Parafuso 3,5x12mm CHT. Tornillo 3,5x12mm CHT. Screw 3,5x12mm CHT.	<b>G</b> 32x  Parafuso 3,0x16mm CHT. Tornillo 3,0x16mm CHT. Screw 3,0x16mm CHT.	<b>H</b> 03x  Parafuso Minifix. Tornillo Minifix. Screw Minifix.	<b>I</b> 86x  Cavilha 5x25mm Cinta 5x25mm Dowel 5x25mm	<b>J</b> 34x  Fixador de fundos Fijador de fondos Bottom fixer
<b>K</b> 130x  Prego 10x10mm Clavo 10x10mm Nail 10x10mm	<b>L</b> 08x  Prego 12x12mm Anelado Clavo 12x12mm Anillado Ringed Nails 12x12mm	<b>M</b> 08x  Suporte cabideiro Soporte de percha Coat hanger support	<b>N</b> 04x  Cabideiro Madeira 519mm Cabezal Madera 519mm 519mm wooden hanger	<b>O</b> 24x  Calço metal 5mm Calzado metálico 5mm 5mm metal shim
<b>P</b> 24x  Dobradiça metal 26 mm Bisagra de metal 26 mm 26 mm metal hinge	<b>Q</b> 16x  Distanciador de corrediça Distanciador de deslizamiento Sliding spacer	<b>R</b> 04x  Corrediça metal 350mm Corredera metal 350mm Sliding metal 350mm	<b>S</b> 18x  Porca sextavada Tuerca hexagonal Hexagon nuts	<b>T</b> 26x  Cantoneira plástica Cantonera plástica Plastic angle brackets
<b>U</b> 10x  Pé "U" 50x40x100mm Pie "U" 50x40x100mm 50x40x100mm "U" feet	<b>V</b> 12x  Porca cilíndrica Tuerca cilíndrica Cylindrical nut	<b>W</b> 08x  Perfil Puxador Revestido MDF 330mm Perfil Tirador Revestido MDF 330mm Profile MDF 330mm Coated Handle	<b>X</b> 01x  Perfil "I" 1154mm Perfil "I" 1154mm Profile "I" 1154mm	<b>Y</b> 03x  Tambor Minifix. Tambor Minifix. Minifix Drum.
<b>Z</b> 02x  Sachê de cola Bolsa de pegamento Glue bag	<b>AA</b> 06x  Adesivo tapa parafuso 17mm Adhesivo tapón de tornillo 17mm Bolt cover adhesive 17mm	<b>AB</b> 24x  Adesivo tapa parafuso 10mm Adhesivo tapón de tornillo 10mm Bolt cover adhesive 10mm		

Requisitos para montagem  
Requisitor para la montaje  
Assembly Requirements

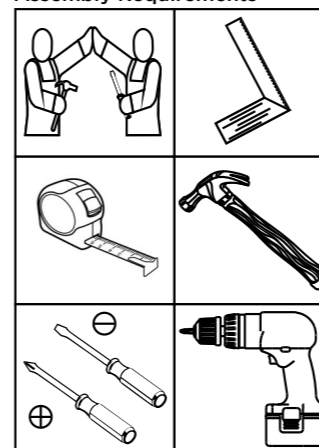

Imagens meramente ilustrativas  
Imágenes meramente ilustrativas  
Images for illustration only

Pesos máximos recomendados com carga distribuída  
Peso máximo recomendado con la carga distribuida  
Recommended maximum weights with evenly distributed.

AVISO

Para limpeza de seu móvel, use uma flanela seca ou umedecida, e não utilize produtos químicos que possam danificar seu produto.

SISTEMA DE MONTAGEM

O sistema de montagem dos produtos, funciona de acordo com a ordem crescente dos números indicados no desenho. Ex: 01, 02, 03, 04... até a conclusão da montagem.

ADVERTENCIA

Para limpieza de su móvil, use una flanela seca o húmeda, y no utilice productos químicos que puedan dañar su producto.

SISTEMA DE MONTAJE

El sistema de montaje de los productos funciona de acuerdo con el orden creciente de los números indicados en el dibujo. Ej.: 01, 02, 03, 04... hasta la conclusión del montaje.

NOTICE

To clean your furniture, use a dry or wet cloth, and do not use chemicals that may damage your product.

ASSEMBLY SYSTEM

The products' assembly system works according to the increasing order of the indicated numbers. For example: 01, 02, 03, 04 ... to the end of the assembly.



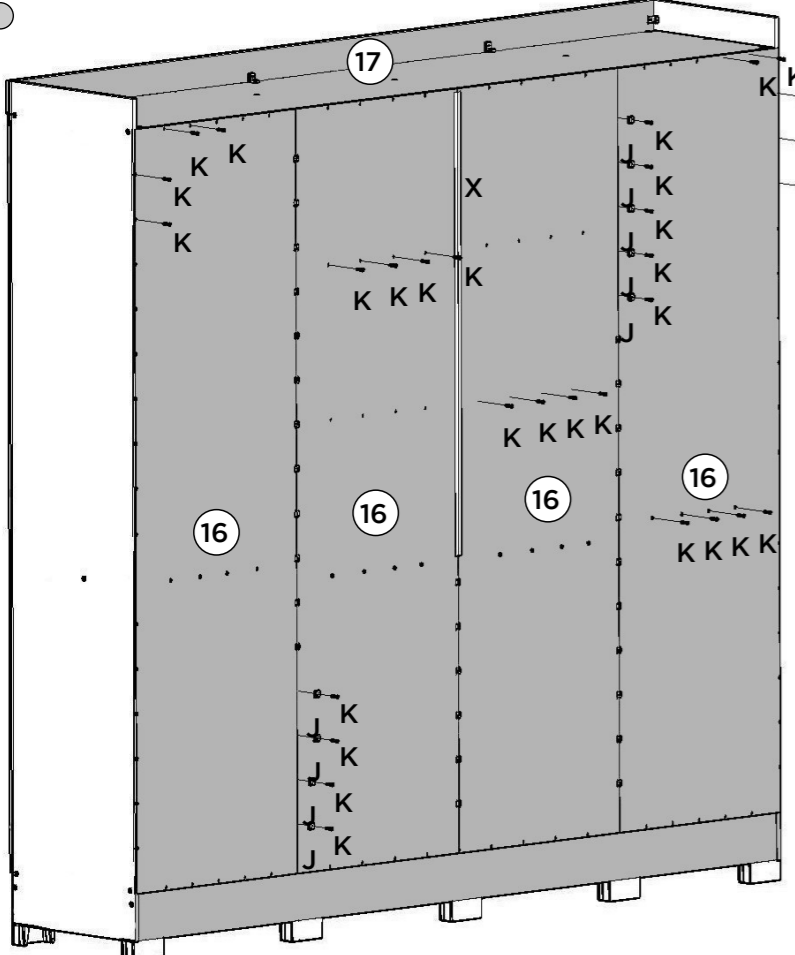

Fixar os pregos a uma distância de 120mm de um para outro.

Fijar las uñas a un distancia de 120 mm uno a otro.

Fix the nails at a distance of 120mm from one to the other

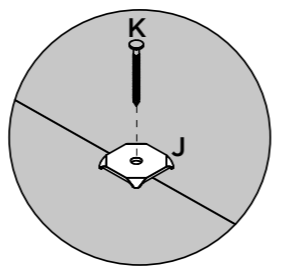
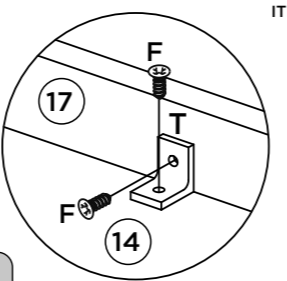

Vídeo: Instalar e regular Dobradiças

Video: Instale y ajuste las bisagras

Video: Install and adjust hinges

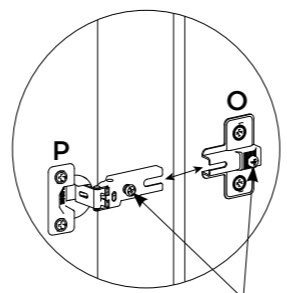

Parafusos indicados na imagem, devem ser inseridos, caso venham soltos no pacote.

Los tornillos indicados en la imagen deben ser insertados, si se sueltan en el paquete.

Screws indicated in the image must be inserted if they are loose in the package.

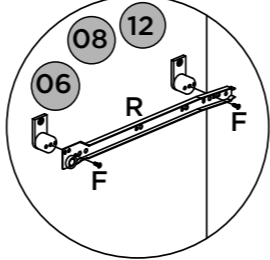
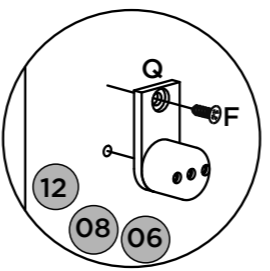
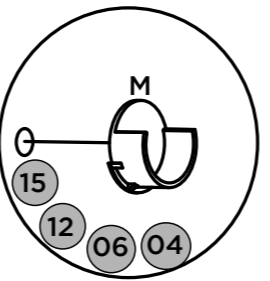
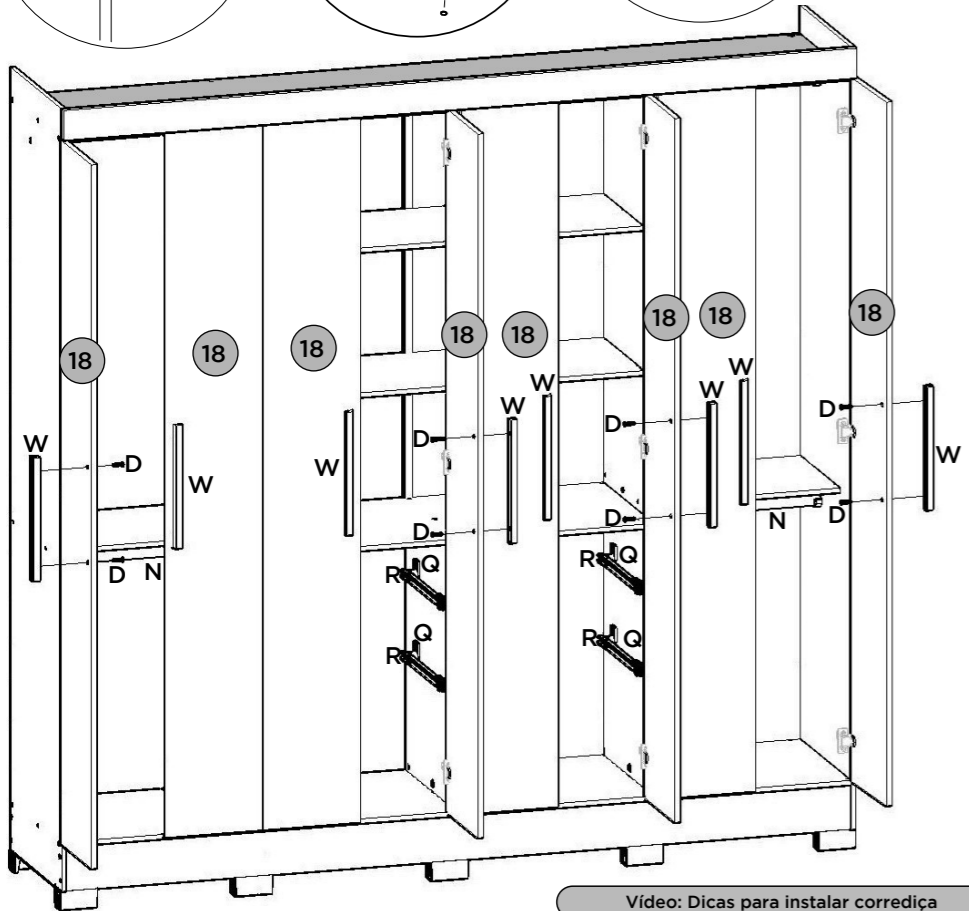
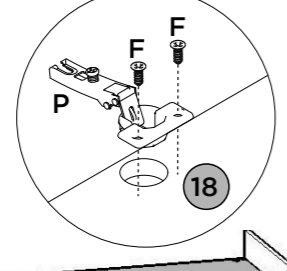
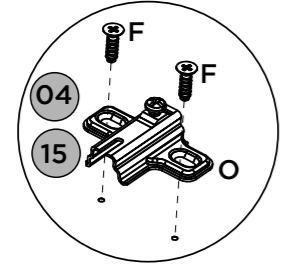
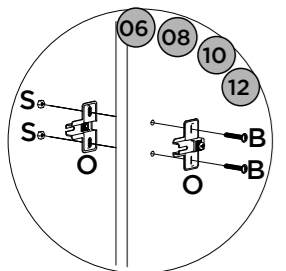

Vídeo: Dicas para instalar corredeira

Video: consejos para instalar la diapositiva

Video: Tips for installing slide

