

GARANTIA E INSTRUÇÕES DE LIMPEZA E CONSERVAÇÃO

GARANTÍA E INSTRUCCIONES DE LIMPIEZA Y MANTENIMIENTO | WARRANTY AND CLEANING AND CARE INSTRUCTIONS

Nosso produtos são garantidos por 90 dias contra defeitos de fabricação. Ao constatar um problema coberto pela garantia, entre em contato com a loja onde o produto foi comprado. Ela estará capacitada para atendê-lo da melhor forma diante de cada caso. Reclamações de garantia somente poderão ser atendidas se o termo de garantia for apresentado no ato de reivindicação, acompanhado de sua nota fiscal de compra.

Nuestros productos están garantidos contra defectos de fabricación por 90 días, a partir de la compra. Ao constatar un problema protegido por la garantía, póngase en contacto con la tienda donde se adquirió el producto. Ella estará capacitada para atenderlo de la mayor manera de acuerdo con cada caso.

Our products are guaranteed against manufacturing defects for 90 days from the date of purchase. When you find a problem covered by the warranty, please contact the store where the product was purchased. The store is able to serve you in the best way in each case.

Exclusões:
Desgaste natural ou danos causados por água, maresia, ferrugem, incêndio, calor, cupins e pragas em geral. Montagem, manutenção e uso inadequado. Não cumprimento das recomendações técnicas do esquema. Montagens e desmontagens após a primeira instalação. Instalações elétricas e outras afins.

Importante
A Linea Brasil não autoriza nenhuma pessoa, loja ou entidade assumir em seu nome qualquer outra garantia que não conste no certificado. A fabricante reserva-se o direito de efetuar nos produtos eventuais modificações que considerar necessárias, sem prejudicar as características essenciais. Os produtos terão peças de assistência para reposição no período de 1 ano a contar de sua retirada do mercado, desde que haja matéria-prima equivalente, observando o dispositivo no Art.32 da Lei 8.078/90 (Cód. Defesa do Consumidor). O atendimento para produtos fora de linha é feito por programação especial, através da loja revendedora sob aprovação de consulta prévia ao fabricante.

Exclusões:
Desgaste natural o daños causados por agua, niebla salina, óxido, fuego, calor, termitas y plagas en general. Mantenimiento y uso inadecuado. Incumplimiento de las recomendaciones técnicas del esquema. Montaje y desmontaje tras la primera instalación. Instalaciones eléctricas y otras similares.

Importante
Linea Brasil no autoriza a ninguna persona, tienda o entidad a asumir en su nombre cualquier otra garantía que no figure en el certificado. El fabricante se reserva el derecho de efectuar en los productos eventuales modificaciones que considere necesarias, sin perjudicar las características esenciales. Los productos tendrán piezas de asistencia para reposición en el período de 1 año a partir de su retirada del mercado. La atención para productos fuera de línea es hecha por programación especial, a través de la tienda revendedora bajo aprobación de consulta previa al fabricante.

Exclusões:
Natural wear and tear or damage caused by water, sea spray, rust, fire, heat, termites and pests in general. Improper assembly, maintenance and use. Failure to comply with the technical recommendations of the scheme. Assembly and disassembly after the first installation. Electrical and other related installations.

Importante
Linea Brasil does not authorize any person, store or entity to assume on its behalf any other warranty that does not appear on the certificate. The manufacturer reserves the right to make in the products any modifications that it considers necessary without prejudice to the essential characteristics. The products will have replacement parts within one year of being withdrawn from the market. The service for off-line products is done by special programming, through the store reseller under prior consultation with the manufacturer.

Para retirar o pó, utilize um pano seco, espanador ou aspirador. Se necessário, para uma limpeza mais efetiva, utilize um pano levemente umedecido com água. Finalize com uma flanela limpa e seca. Evite materiais abrasivos, umidade e calor.

Para quitar el polvo, utilice un paño seco, un plumero o una aspiradora. Si es necesario, para una limpieza más eficaz, utilice un paño ligeramente humedecido con agua. Termine con una flanela limpia y seca. Evite materiales abrasivos, humedad y calor.

To remove dust, use a dry cloth, duster or vacuum cleaner. If necessary, for more effective cleaning, use a cloth slightly dampened with water. Finish with a clean, dry flannel. Avoid abrasive materials, humidity and heat.

VOLUME	ITEM	PEÇA	DESCRIÇÃO	DIMENSÕES (mm)	QUANTIDADE
Box	Item	Part	Description	Dimension	Amount
1	1	510546001	BASE ESQUERDA BASE IZQUIERDA LEFT BASE	634 318 12	1
1	2	510546002	BASE CENTRAL BASE CENTRAL CENTRAL BASE	578 302 12	1
2	3	510546003	BASE DIREITA BASE DERECHA RIGHT BASE	634 318 12	1
2	4	510546004	DIVISAO DIVISION DIVISION	302 215 12	2
1	5	510546005	APOIO TAMPO SOPORTE SUPERIOR TOP SUPPORT	578 30 25	1
1	6	510546006	LATERAL ESQUERDA LADO IZQUIERDO LEFT SIDE	316 215 12	1
1	7	510546007	FUNDO TRASERO BACK	1644 215 15	1
1	8	510546008	LATERAL DIREITA LADO DERECHO RIGHT SIDE	316 215 12	1
1	9	510546009	TAMPO SUPERIOR TOP	1746 318 12	1
1	10	510546010	ENGROSSO FRONTAL TRASERO ENGRASAMIENTO FRONTAL PANEL TRASERO FRONT THICKENING REAR PANEL	1683 60 12	2
1	11	510546011	ENGROSSO LATERAL ENGRASAMIENTO LATERAL SIDE THICKENING	131 60 12	2
1	12	510546012	ENGROSSO CENTRAL ENGRASAMIENTO CENTRAL CENTRAL THICKENING	131 60 12	3
1	13	510546013	VISTA FRONTAL VISTA FRONTAL FRONT VIEW	568 31 15	2
1	14	510546014	MOLDURA LATERAL MARCO LATERAL SIDE FRAME	245 114 25	4
2	15	510546015	MOLDURA CURVA NICHU MARCO CURVO NICHU CURVED FRAME NICHE	245 81 30	4
1	16	510546016	TAMPO SUPERIOR SUPERIOR SUPERIOR TOP TOP	1800 356 9	1
1	17	510546017	TRAVESSA PAINEL NICHU NICHU DE LA BARRA TRANSVERSAL DEL PANEL PANEL CROSSBAR NICHE	678 70 18	2
1	18	510546018	TRAVESSA PAREDE NICHU NICHU DE LA BARRA TRANSVERSAL DE LA PARED WALL CROSSBAR NICHE	678 70 18	2
2	19	510546019	PORTA PUERTA DOOR	538 245 15	2
2	20	510546020	PAINEL DIREITA PANEL DERECHO RIGHT PANEL	1350 555 15	1
2	21	510546021	PAINEL CENTRAL PANEL CENTRAL CENTRAL PANEL	1350 555 15	1
2	22	510546022	PAINEL ESQUERDO PANEL IZQUIERDO LEFT PANEL	1350 555 15	1
1	23	510546023	FUNDO UNIAO JUNTA TRASERA BACK JOINT	1348 23 2.8	2
2	24	510546024	APOIO SUPERIOR INFERIOR SOPORTE SUPERIOR SOPORTE INFERIOR UPPER SUPPORT LOWER SUPPORT	1350 70 15	2
1	25	510546025	APOIO TRASERO CENTRAL SOPORTE TRASERO CENTRAL CENTRAL REAR SUPPORT	723 60 15	2
1	26	510546026	APOIO PAINEL TRASERO SOPORTE DEL PANEL TRASERO REAR PANEL SUPPORT	160 60 15	5
1	27	510546027	PRATELEIRA SUPERIOR ESTANTE SUPERIOR UPPER SHELF	1670 145 25	1
1	28	510546028	TRAVESSA SUPERIOR TRANSVERSAL SUPERIOR UPPER CROSSBAR	1360 100 15	1
1	29	510546029	PAINEL TRASERO PANEL TRASERO REAR PANEL	1679 142 15	1
2	30	510546030	MOLDURA CURVA PAINEL MARCO DEL PANEL CURVO CURVED PANEL FRAME	1350 81 30	2
2	31	510546031	TRAVESSA PAINEL TRANSVERSAL DEL PANEL PANEL CROSSBAR	1350 70 15	1
2	32	510546032	TRAVESSA PAREDE TRANSVERSAL DE LA PARED WALL CROSSBAR	1350 70 15	1

TABELA DE ACESSÓRIOS | TABLA DE ACCESORIOS | ACCESSORIES TABLE

Código Code	Descrição Description Description	Quantidade Amount
A 160001001	COLA PARA MONTAGEM COLA PARA MONTAJE ASSEMBLY GLUE	2
B 160001003	CAVILHAS 8X20MM ESPIGAS 8X20MM DOWELS 8X20MM	10
C 160001005	CAVILHA 8X55 ESPIGA 8X55 DOWEL 8X55	2
D 160001009	ARRUELA ARANDELA WASHER	13
E 160001011	SUPORTE ANGULAR CENTRAL MARRON SOPORTE ANGULAR CENTRAL MARRÓN BROWN CENTRAL ANGLE BRACKET	6
F 160001023	CAVILHA 6X30MM ESPIGA 6X30MM DOWEL 6X30MM	24
G 160001024	PINO GIROFIX PASADOR GIROFIX GIROFIX PIN	44
H 160001025	CASTANHA DO MINI-GIROFIX TUERCA DEL MINI-GIROFIX MINI-GIROFIX NUT	44
I 160001034	CHAPA JUNCAD PLACA DE UNIÓN JOINING PLATE	29
J 160002002	TAMPA ADESIVA 18MM TAPA ADHESIVA 18MM ADHESIVE COVER 18MM	12
K 160002005	GUÍA CABO GUÍA DE CABLE CABLE GUIDE	2
L 160002006	BUCHA 8MM (PAREDE) TACO 8MM (PARED) WALL PLUG 8MM (WALL)	13
M 160002012	GIZ DE CORRECAO TIZA DE CORRECCION CORRECTION CHALK	2
N 160002014	DISTANCIADOR DE PAINEL DISTANCIADOR DE PANEL PANEL SPACER	6
O 160003013	BATENTE SILICONE TOPE DE SILICONA SILICONE BUMPER	4
P 160003002	DOBRADICA CANECA 26MM BISAGRA DE CAZOLETA 26MM 26MM CUP HINGE	4
Q 160003017	PISTAO A GAS INVERTIDO PISTÓN A GAS INVERTIDA INVERTED GAS PISTON	2
R 160004001	SUPORTE PRATELEIRA U SOPORTE DE ESTANTE U U SHELF SUPPORT	4
S 160005088	PUXADOR LIVORNO TIRADOR LIVORNO LIVORNO HANDLE	2
T 160006001	PARAFUSO 3,5X12 CABECA CHATA TORNILLO 3,5X12 CABEZA PLANA SCREW 3.5X12 FLAT HEAD	8
U 160006006	PARAFUSO 3,5X40 CABECA CHATA TORNILLO 3,5X40 CABEZA PLANA SCREW 3.5X40 FLAT HEAD	25
V 160006008	PARAFUSO 4,5X25 CABECA CHATA TORNILLO 4,5X25 CABEZA PLANA SCREW 4.5X25 FLAT HEAD	43
W 160006010	PARAFUSO 4,5X50 CABECA CHATA TORNILLO 4,5X50 CABEZA PLANA SCREW 4.5X50 FLAT HEAD	19
X 160006015	PARAFUSO 6,0X75 CABECA CHATA TORNILLO 6,0X75 CABEZA PLANA SCREW 6.0X75 FLAT HEAD	13
Y 160006016	PARAFUSO 3,5X12 CABECA FLANGEADA TORNILLO 3,5X12 CABEZA BRIDADA SCREW 3.5X12 FLANGED HEAD	90
Z 160006018	PARAFUSO 4,5X22 CABECA CHATA TORNILLO 4,5X22 CABEZA PLANA SCREW 4.5X22 FLAT HEAD	28
AA 160006019	PARAFUSO M4 10MM CHATA TORNILLO M4 10MM PLANA SCREW M4 10MM FLAT HEAD	8
AB 160006020	PINO UNIAO M4 12MM CHATA PASADOR DE UNION M4 12MM PLANA UNION PIN M4 12MM FLAT HEAD	8
AC 160006042	PARAFUSO 3,5X30 CABECA FLANGEADA TORNILLO 3,5X30 CABEZA BRIDADA SCREW 3.5X30 FLANGED HEAD	30
AD 160006053	PARAFUSO ESTRUTURAL 7X40 CABECA CHATA TORNILLO ESTRUCTURAL 7X40 CABEZA PLANA STRUCTURAL SCREW 7X40 FLAT HEAD	2
AE 160010044	KIT FITA LED LUZ BRANCA KIT CINTA LED LUZ BLANCA WHITE LIGHT LED STRIP KIT	1
AF 160011085	ACABAMENTO LENTE PARA LED ACABADO LENTE PARA LED LED LENS FINISH	1
AG 180001097	VIDRO INCOLOR VIDRIO INCOLORO CLEAR GLASS	1
AH 180001004	CAVILHAS 8X30MM ESPIGAS 8X30MM DOWELS 8X30MM	9
AI 180001055	FITA DUPLA FACE CINTA DE DOBLE CARA DOUBLE-SIDED TAPE	6

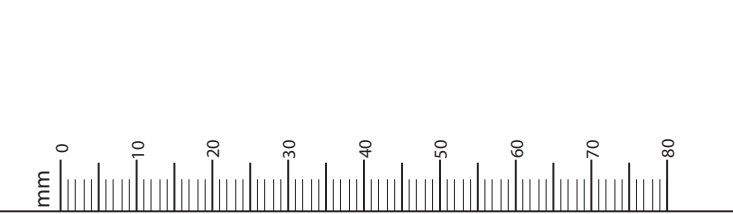

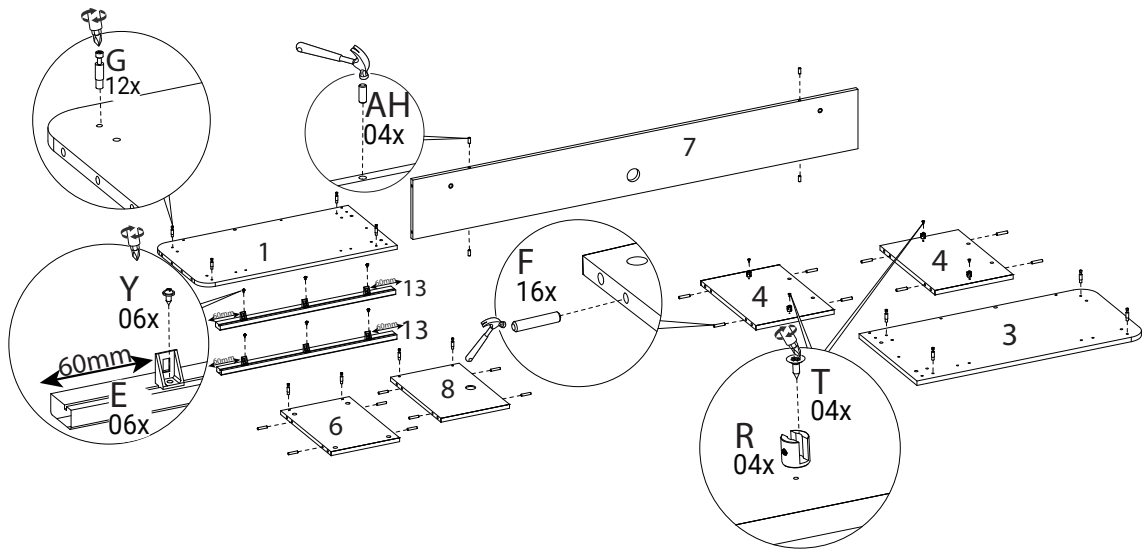
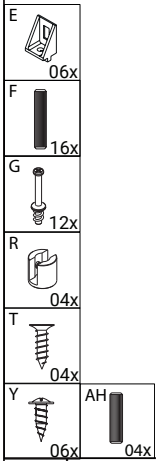
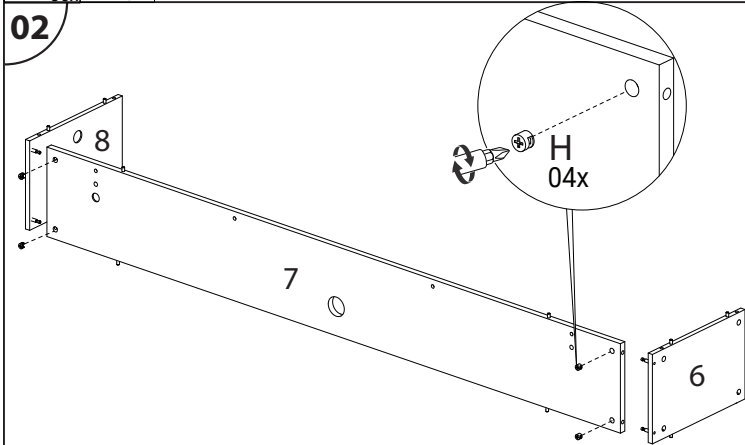
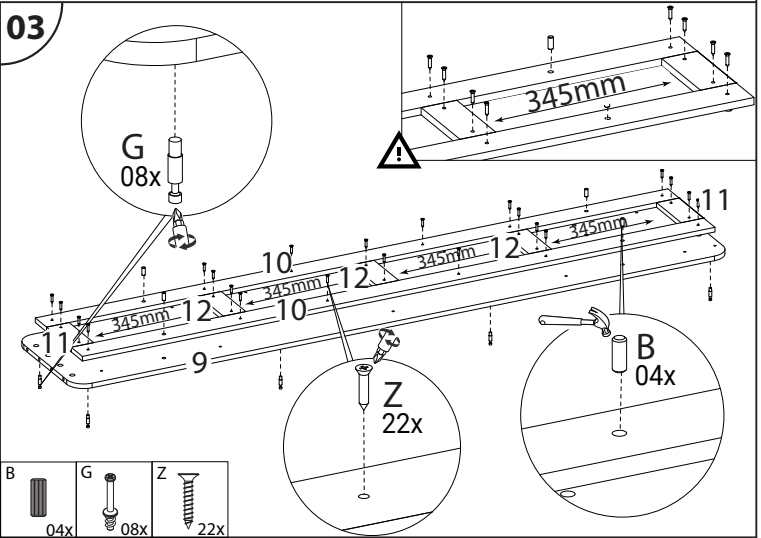
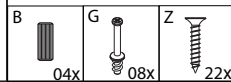
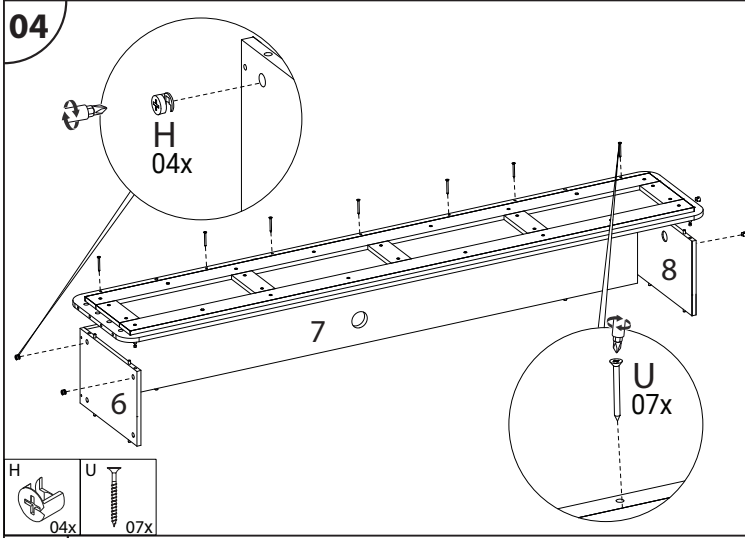
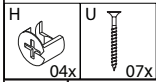
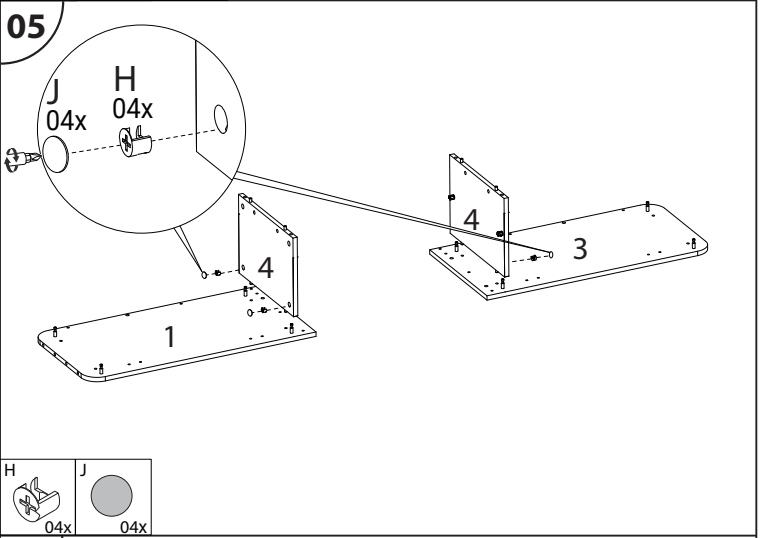
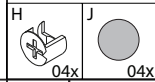
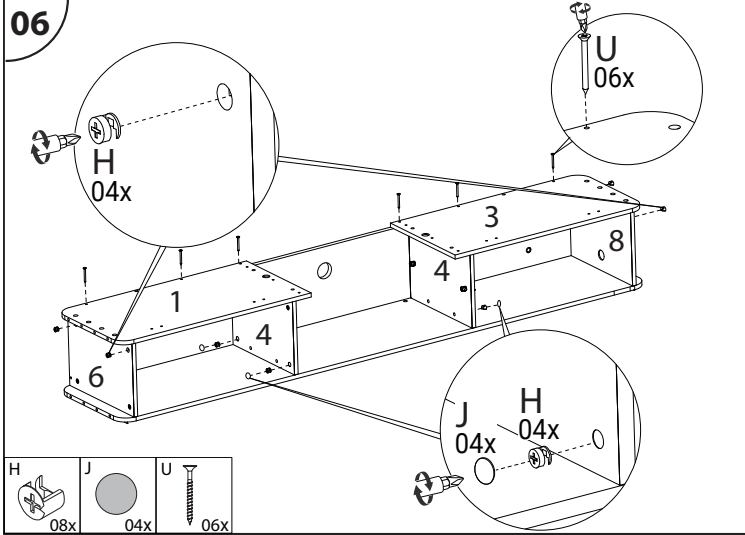
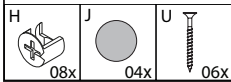
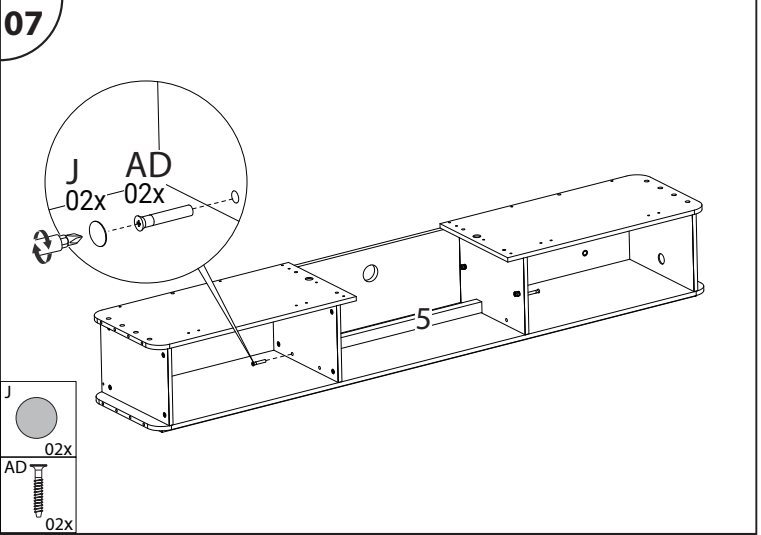
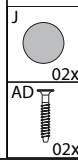
01**02****03****04****05****06****07**

08

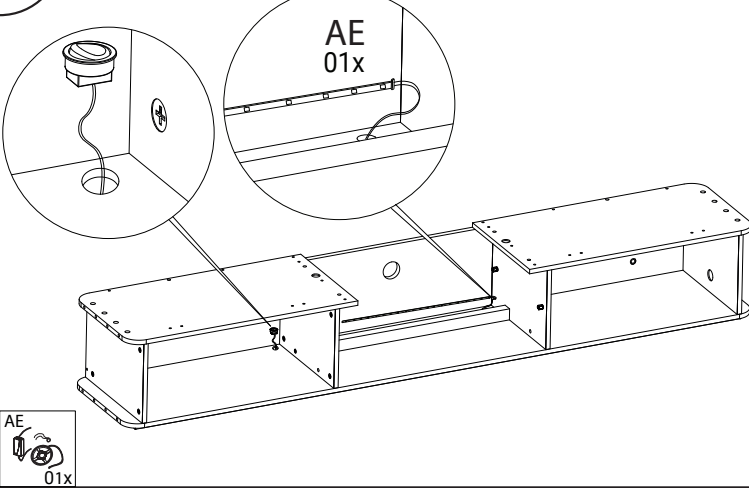

09

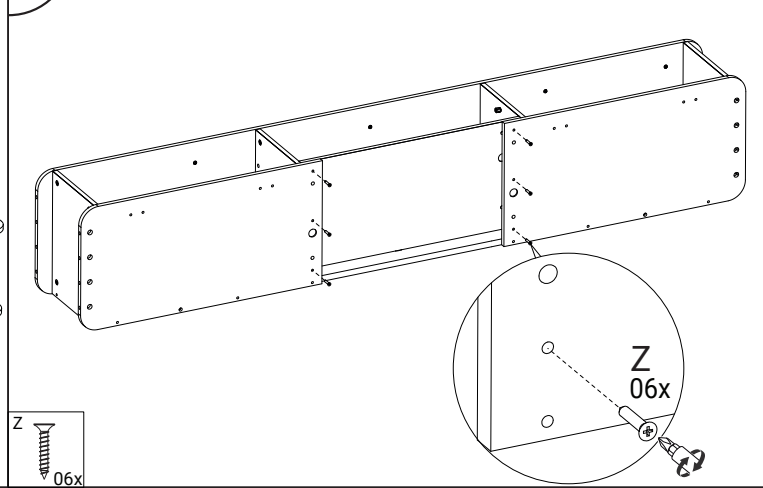

10

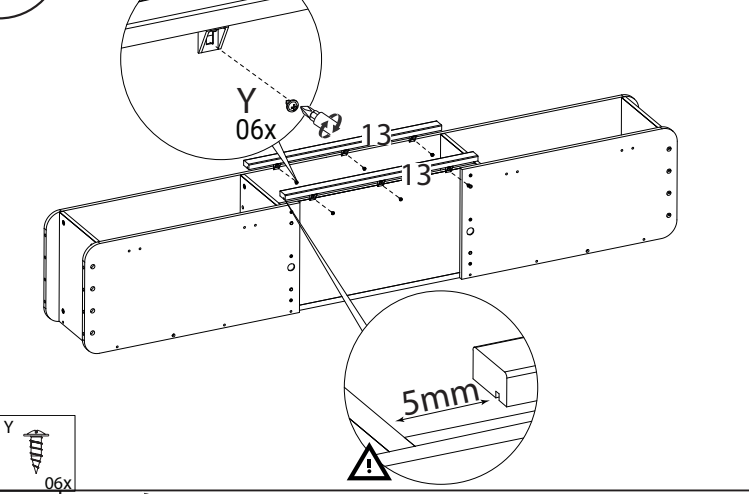

11

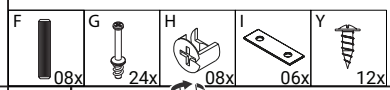
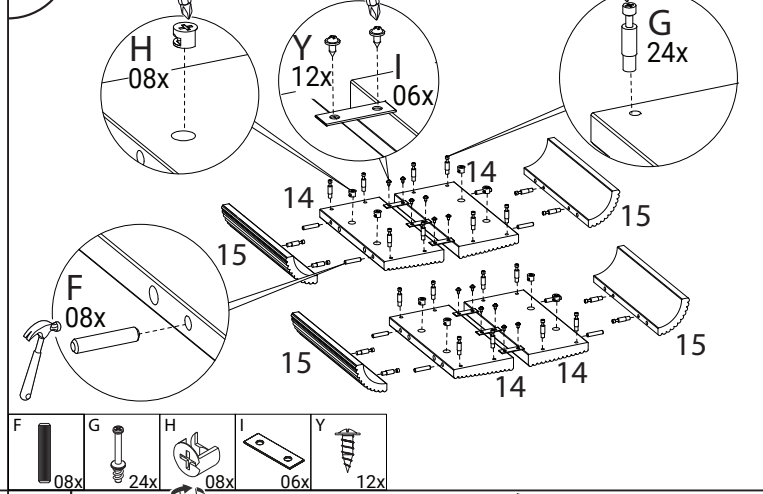

12

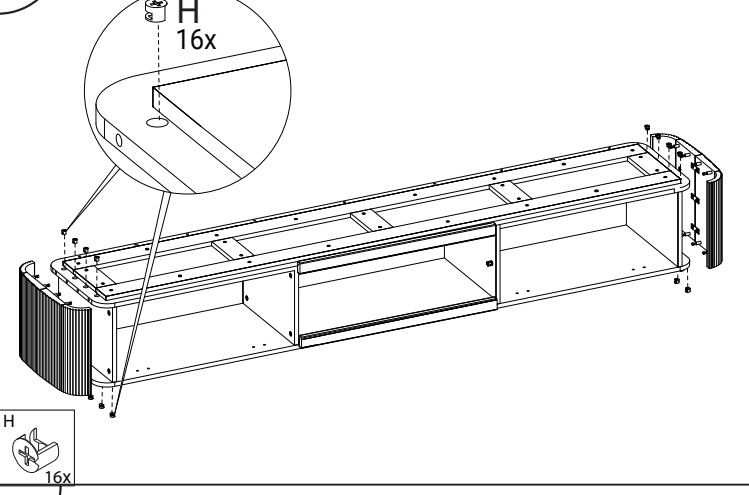

13

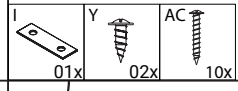
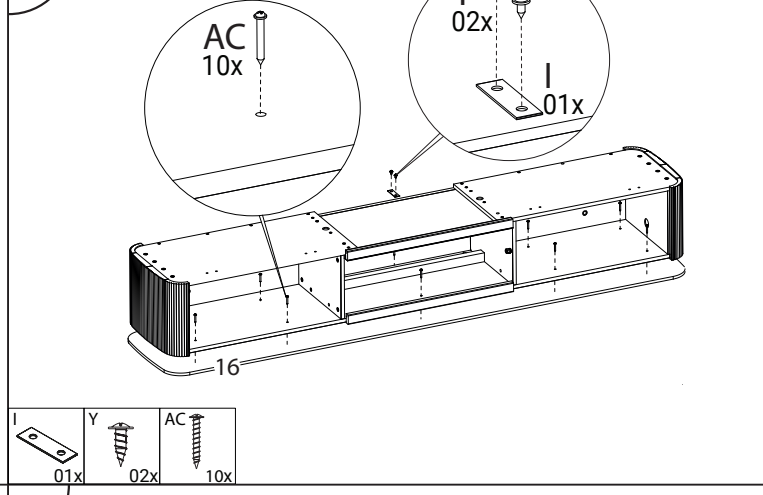

14

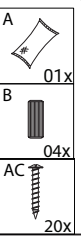
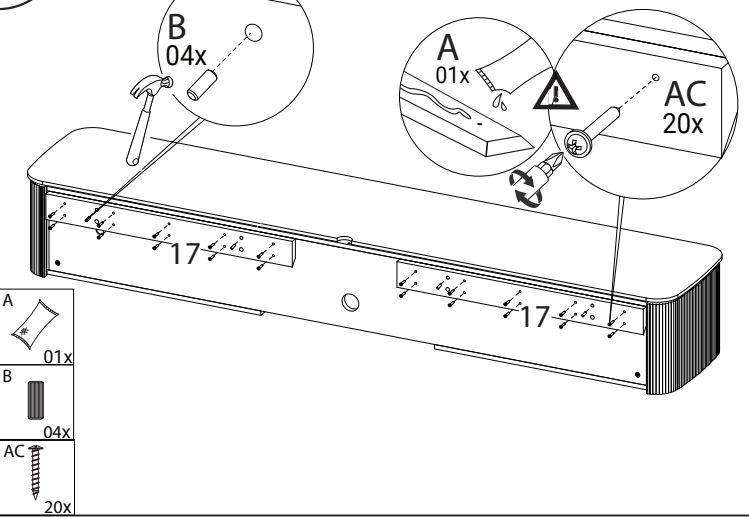

15

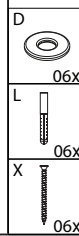
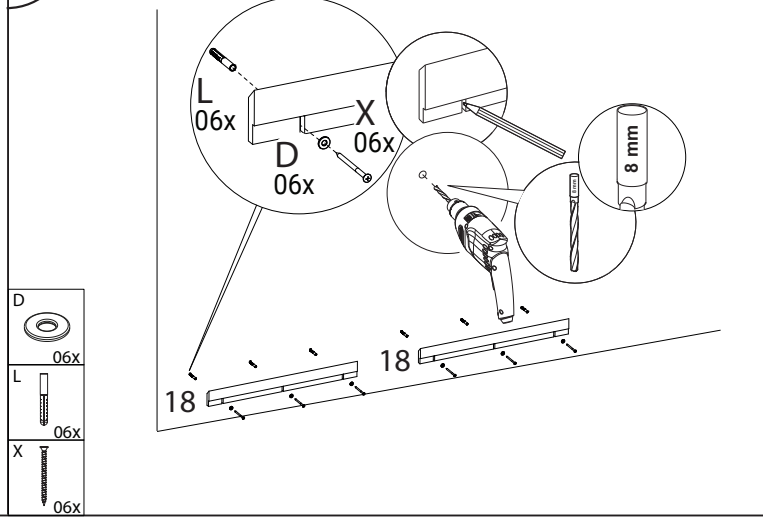

16

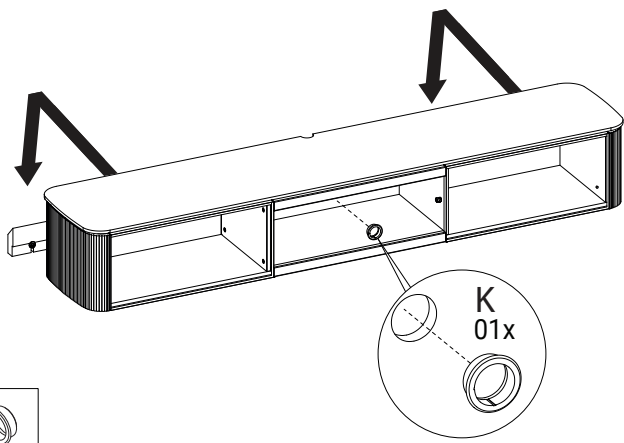

17

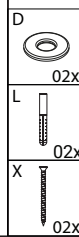
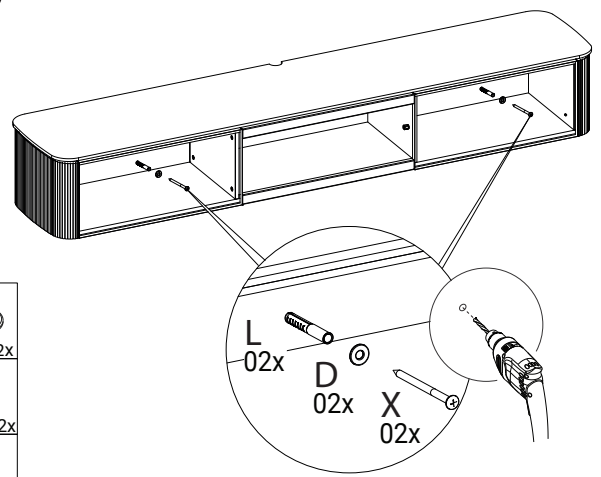

18

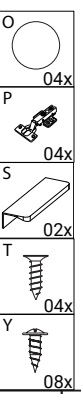
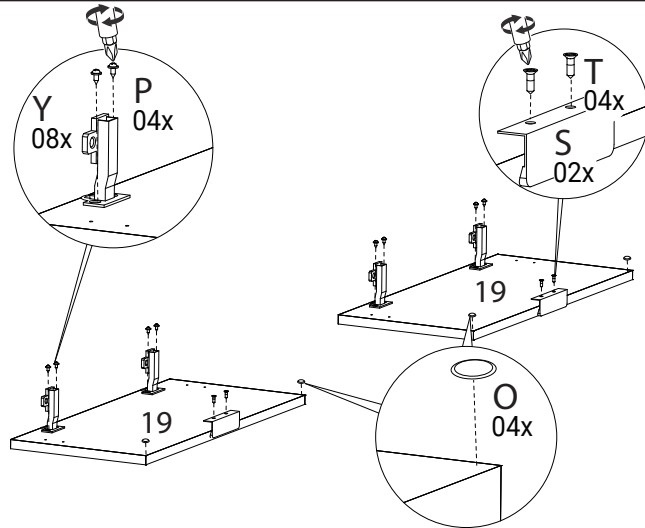

19

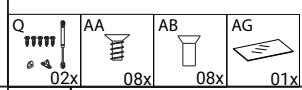
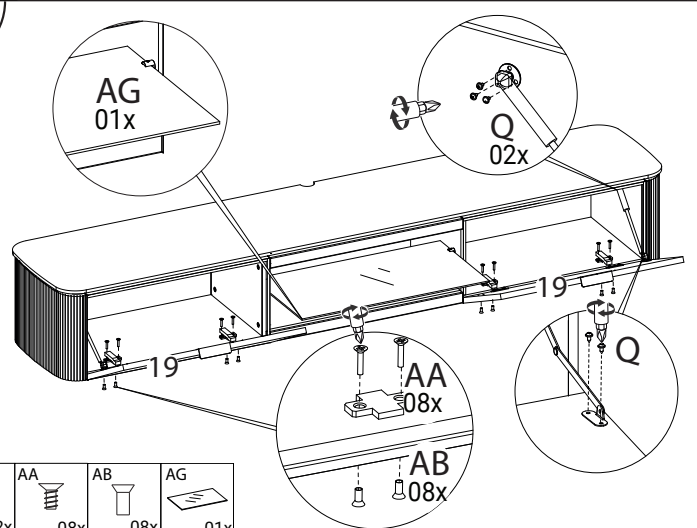

20

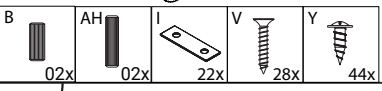
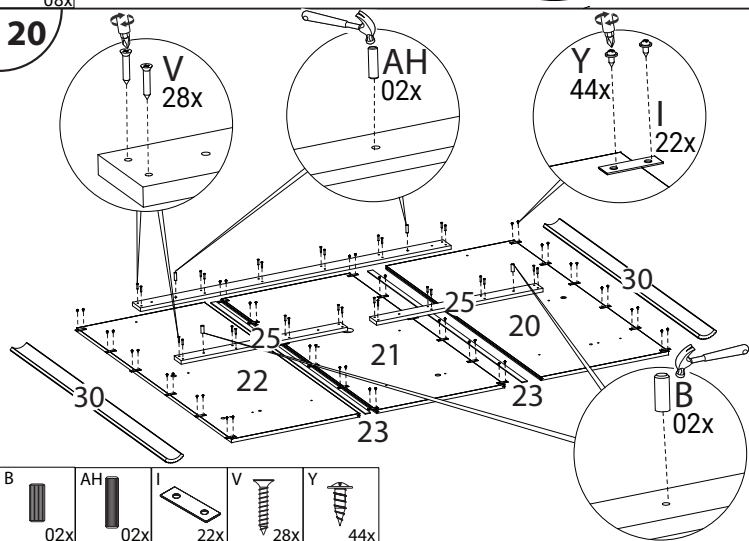

21

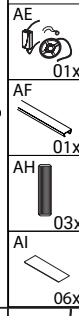
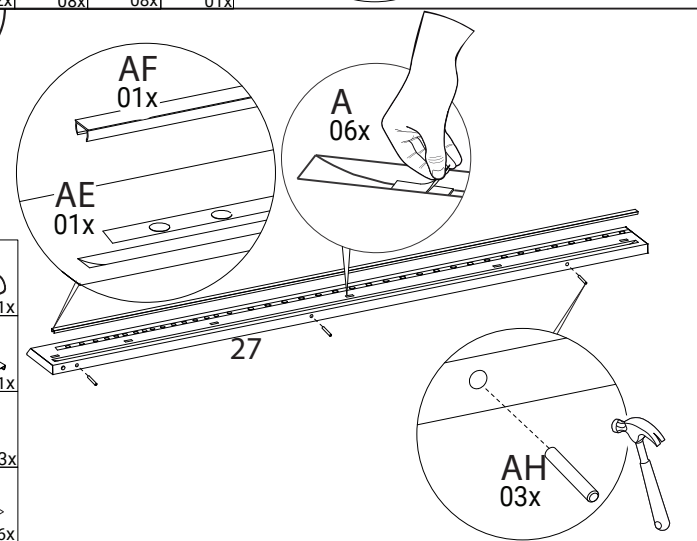

22

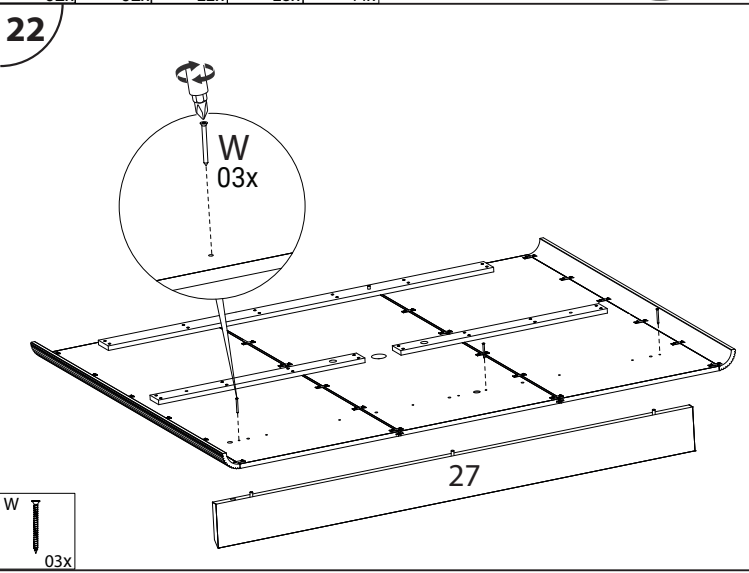

23

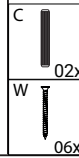
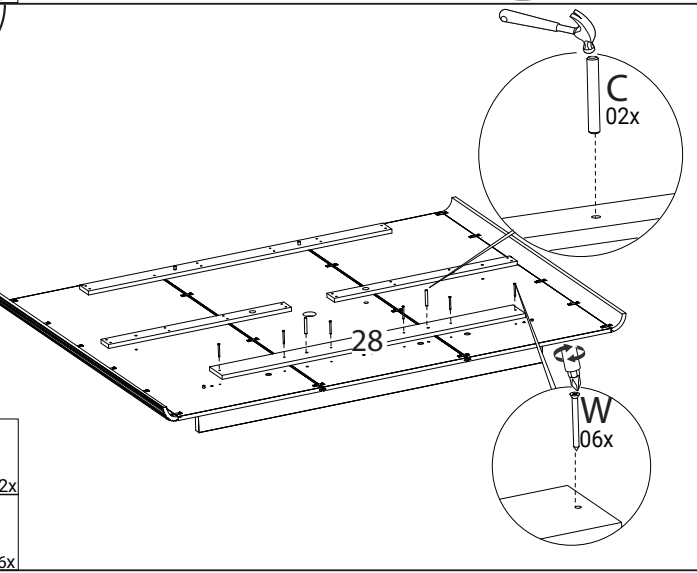

24

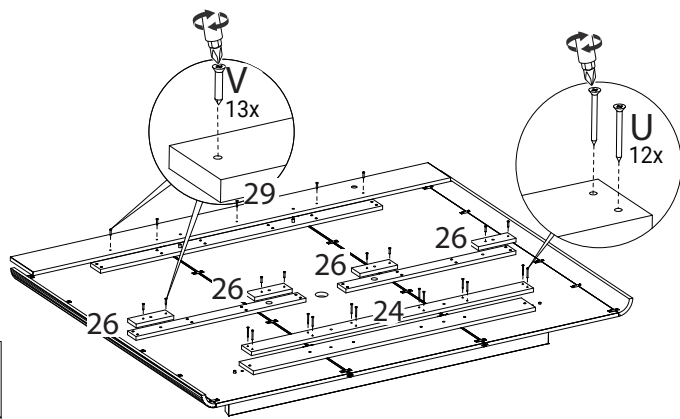

- U 12x
- V 13x

25

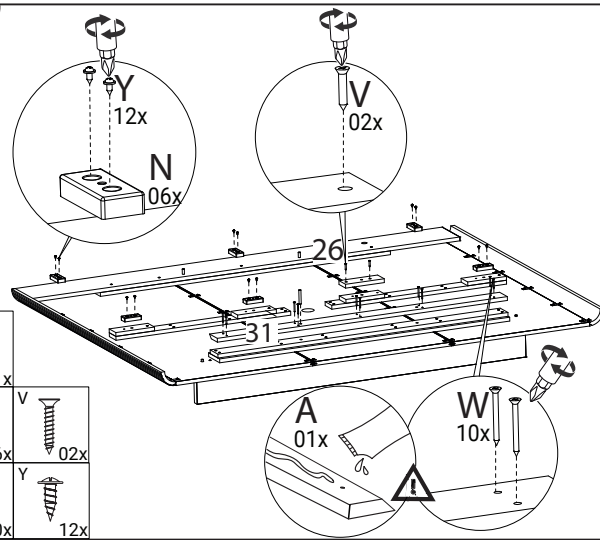

- A 01x
- N 06x
- V 02x
- W 10x
- Y 12x

26

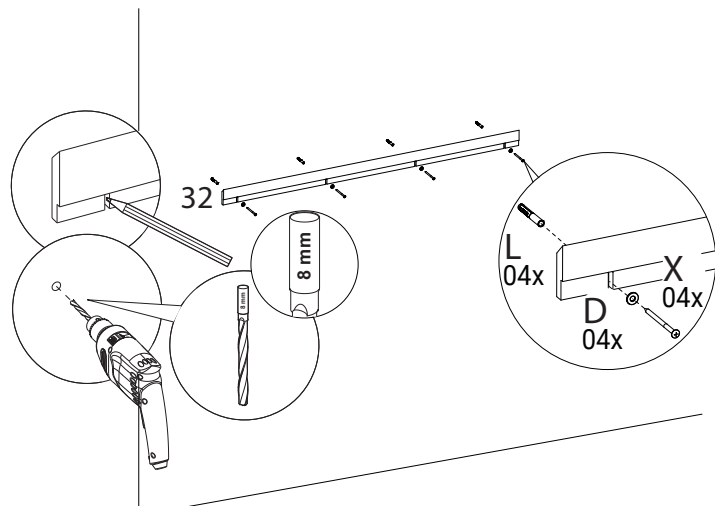

- D 04x
- L 04x
- X 04x

27

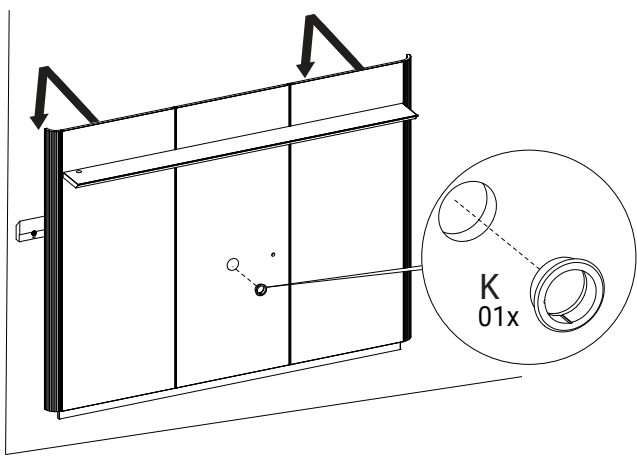

- K 01x

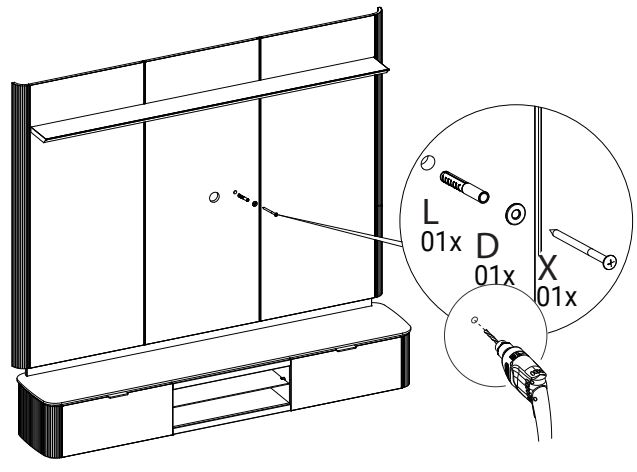

- D 01x
- L 01x
- X 01x

28

