

# ASSEMBLY INSTRUCTIONS

Ref.: 200709 - ELB0071.01 | Review 01

INSTRUCTIONS DE MONTAGE | MANUAL DE ARMADO | ESQUEMA DE MONTAGEM

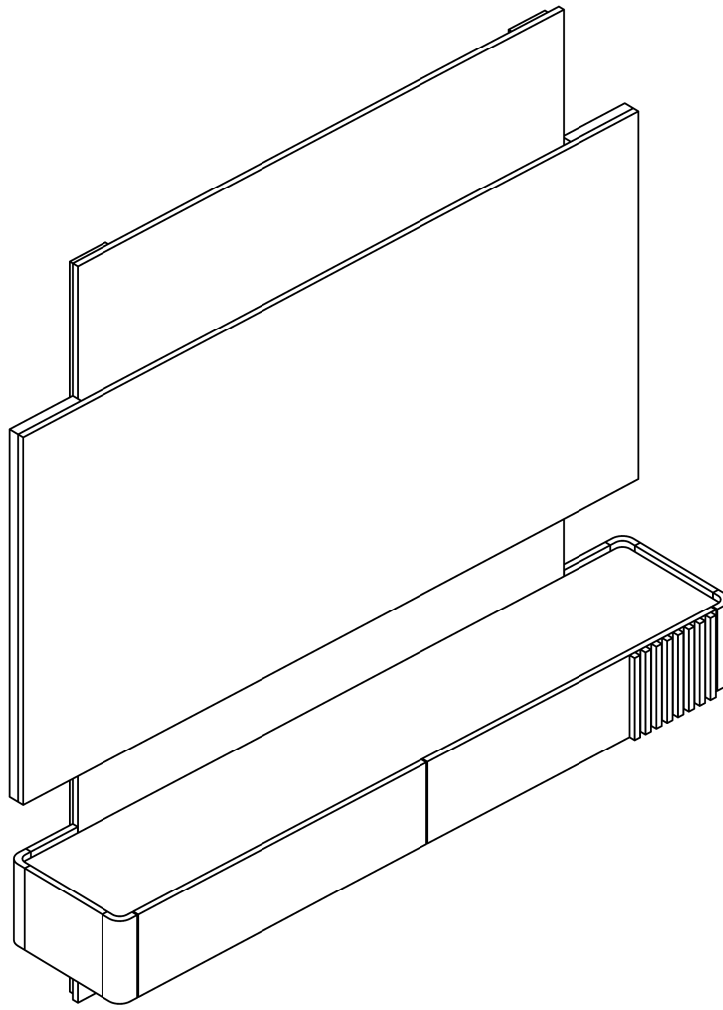

## YOU WILL NEED

TU AURAS BESOIN DE | NECESITARÁ | VOCÊ VAI PRECISAR

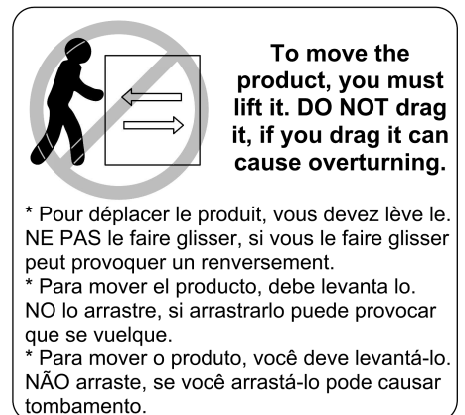
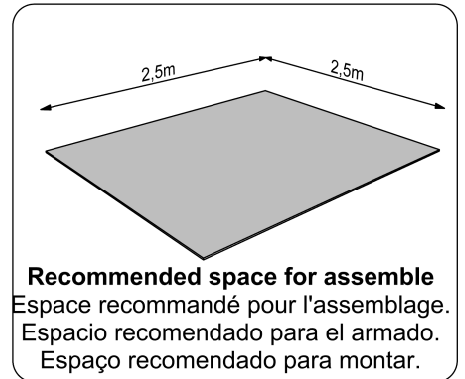
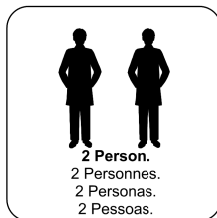
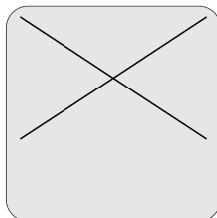
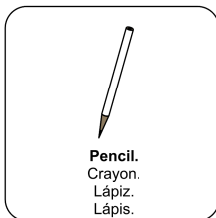
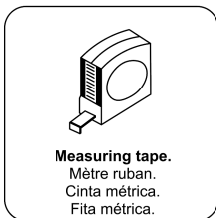
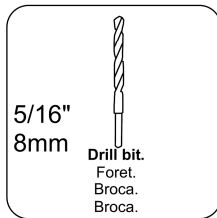
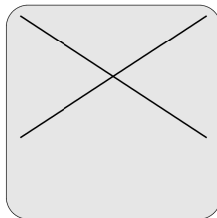
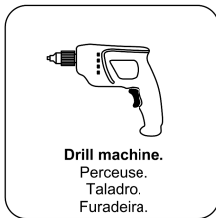
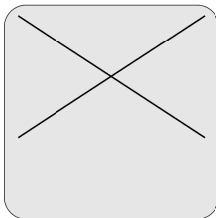
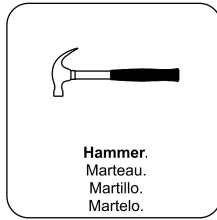
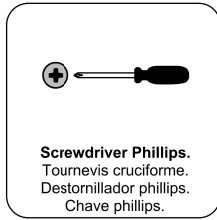
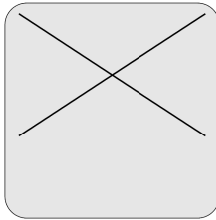
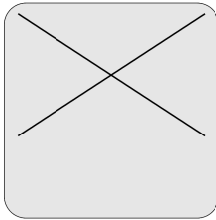







## Tools not included

Outils non inclus | Herramientas no incluidas | Ferramentas não inclusas

# ACCESSORIES IDENTIFICATION

IDENTIFICATION DES ACCESSOIRES | IDENTIFICACIÓN DE ACCESORIOS  
IDENTIFICAÇÃO DOS ACESSÓRIOS

<b>A</b>		Qty./Qtd. <b>14</b>
Wooden dowel / Chevilles en bois / Taquete / Cavilha		
<b>AL</b>		Qty./Qtd. <b>8</b>
Flanged head screw / Vis à tête bride / Tornillo de cabeza flangeada / Parafuso Flangeado		
<b>C</b>		Qty./Qtd. <b>1</b>
Structural screw / Vis à tête structurelle / Tornillo estructural / Parafuso Estrutural		
<b>CI</b>		Qty./Qtd. <b>18</b>
Pan head screw / Vis à tête bombée / Tornillo de pan / Parafuso Panela		
<b>E</b>		Qty./Qtd. <b>2</b>
Metallic bracket / Support métallique / Suporte de meta		
<b>G</b>		Qty./Qtd. <b>21</b>
Simple minifix screw / Vis minifix simple / Tornillo minifix simple / Haste Minifix Simples		
<b>H</b>		Qty./Qtd. <b>21</b>
Drum lock / Verrouillage du tambour / Tambor minifix / Tambor de Minifix		
<b>N</b>		Qty./Qtd. <b>20</b>
Pan head screw / Vis à tête bombée / Tornillo de pan / Parafuso Panela		
<b>O</b>		Qty./Qtd. <b>11</b>
Pan head screw / Vis à tête bombée / Tornillo de pan / Parafuso Panela		
<b>P</b>		Qty./Qtd. <b>18</b>
Wooden dowel / Chevilles en bois / Taquete / Cavilha		
<b>Q</b>		Qty./Qtd. <b>4</b>
Metal hinge straight / Charnière métallique droite / Bisagra recta / Dobradiça Reta		
<b>S</b>		Qty./Qtd. <b>4</b>
Bushing / Douille expansive / Tapón / Bucha Plástica		
<b>T</b>		Qty./Qtd. <b>4</b>
Flanged head screw / Vis à tête bride / Tornillo de cabeza flangeada/ Parafuso flangeado		

# PARTS IDENTIFICATION

IDENTIFICATION DES PIÈCES | IDENTIFICACIÓN DE PIEZAS | IDENTIFICAÇÃO DAS PEÇAS

<b>01</b>	Top Plan de Travail Tapa Tampo	Qty./Qtd. <b>01</b>	<b>15</b>	Top Tray Plateau Supérieure Traviesa Superior Travessa Superior	Qty./Qtd. <b>01</b>
<b>02</b>	Base Base Base Base	Qty./Qtd. <b>01</b>	<b>16</b>	Bottom holder Support Inférieur Titular Inferior Suporte Inferior	Qty./Qtd. <b>01</b>
<b>03</b>	Top Panel Panneau Supérieure Panel Superior Painel Superior	Qty./Qtd. <b>01</b>	<b>17</b>	Center Tray Plateau Centrale Traviesa Central Travessa Central	Qty./Qtd. <b>01</b>
<b>04</b>	Bottom Panel Panneau Inférieur Panel Inferior Painel Inferior	Qty./Qtd. <b>01</b>	<b>18</b>	Top Tray Plateau Supérieure Traviesa Superior Travessa Superior	Qty./Qtd. <b>02</b>
<b>05</b>	Panel Panneau Panel Painel	Qty./Qtd. <b>01</b>	<b>20</b>	Bottom Tray Plateau Inférieure Traviesa Inferior Travessa Inferior	Qty./Qtd. <b>02</b>
<b>06</b>	Frame Cadre Marco Moldura	Qty./Qtd. <b>02</b>			
<b>07</b>	Side Côté Lateral Lateral	Qty./Qtd. <b>02</b>			
<b>09</b>	Center Panel Panneau Centrale Panel Central Painel Central	Qty./Qtd. <b>02</b>			
<b>10</b>	Tray Plateau Traviesa Travessa	Qty./Qtd. <b>01</b>			
<b>11</b>	Door Porte Puerta Porta	Qty./Qtd. <b>01</b>			
<b>14</b>	Right Door Porte Droite Porta Derecho Porta Direita	Qty./Qtd. <b>01</b>			

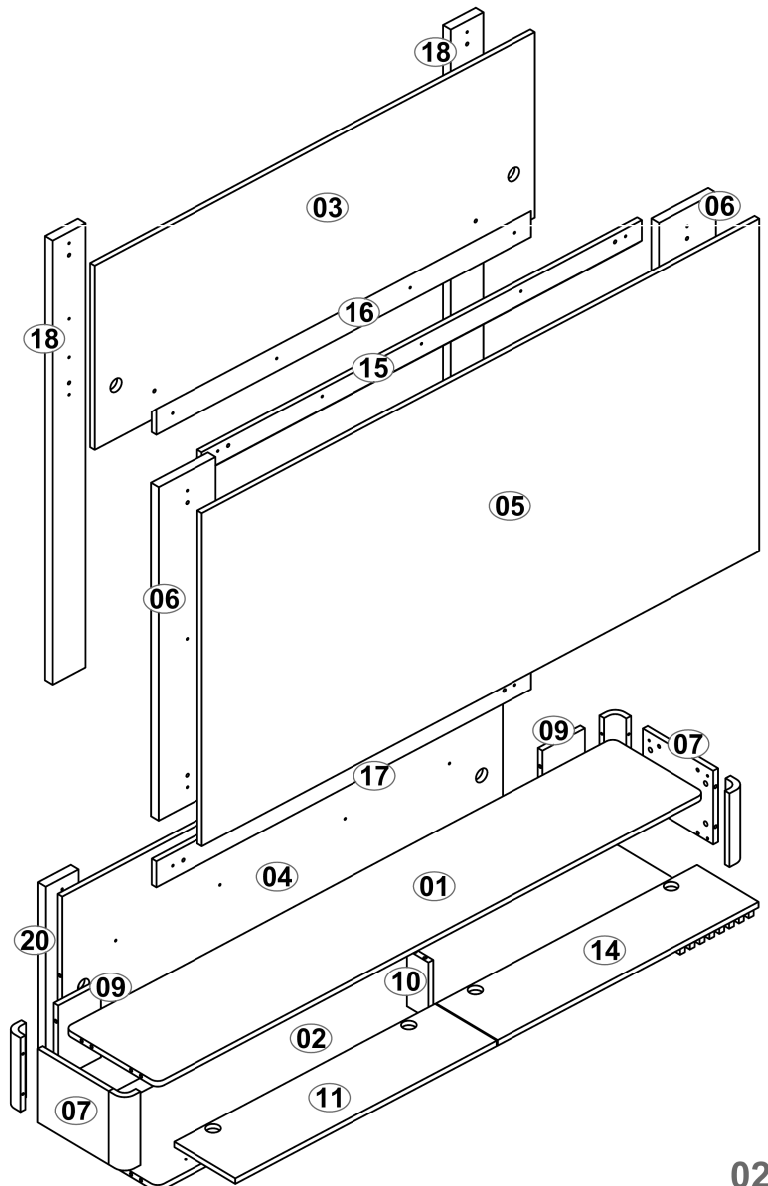

PRE-ASSEMBLY - PRÉ-ASSEMBLAGE - PRE-ARMADO  
PRÉ-MONTAGEM

01 -

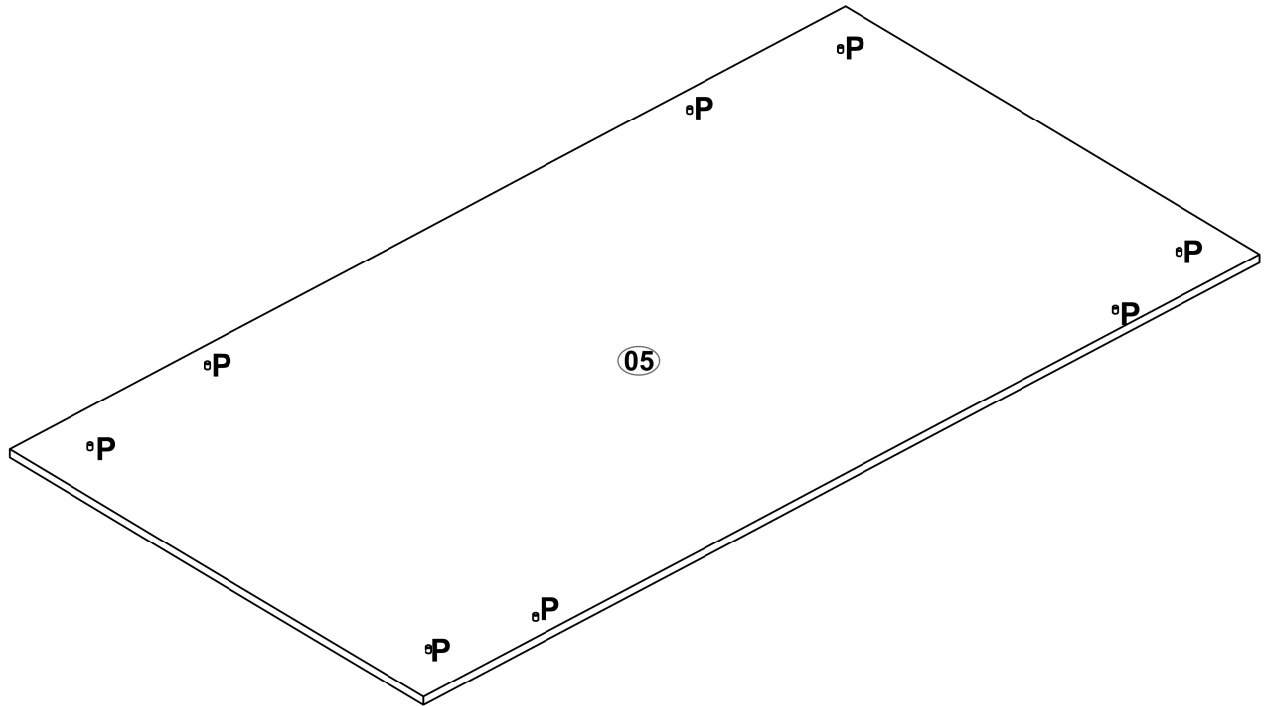

02 -

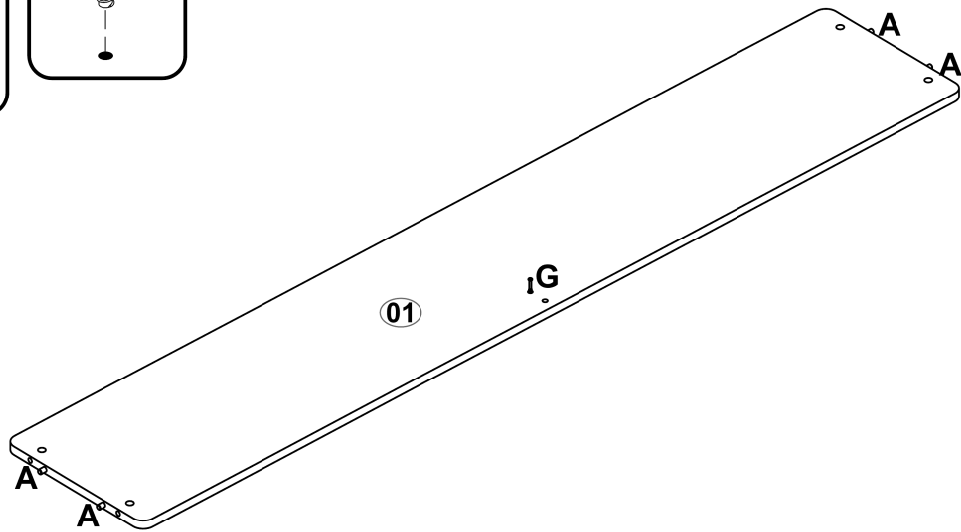
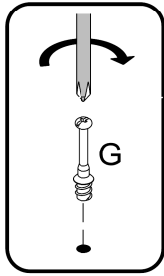
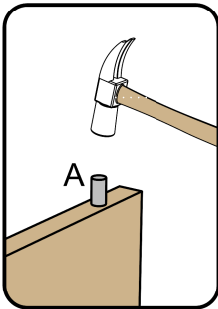

03 -

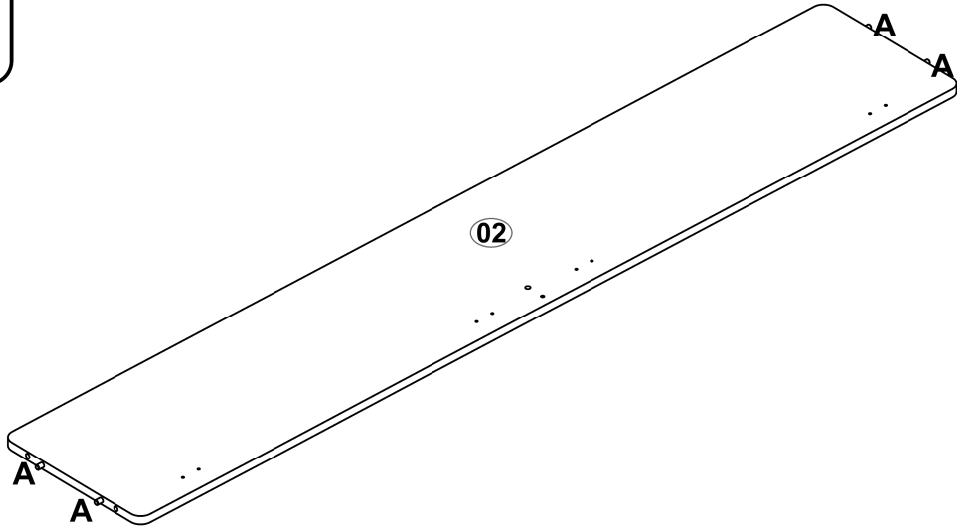
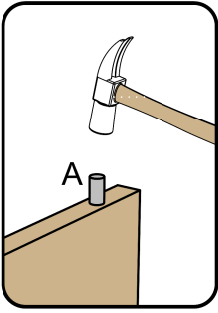

04 -

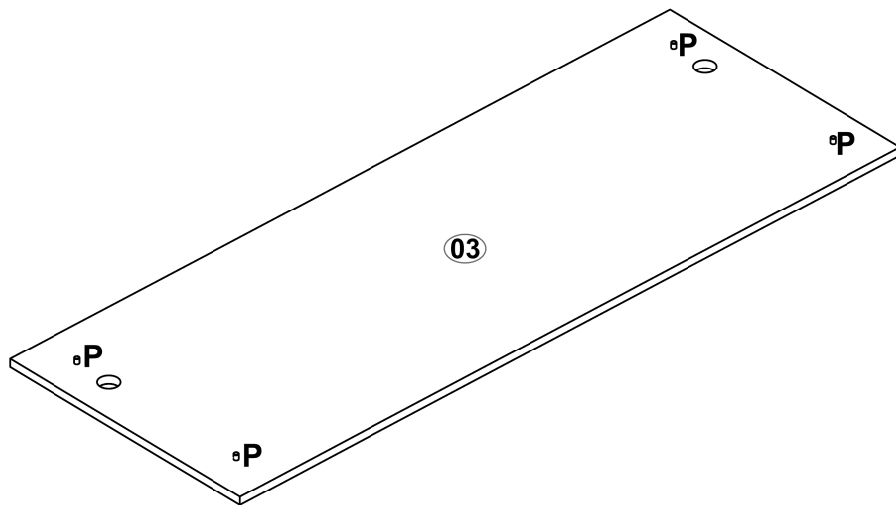

05 -

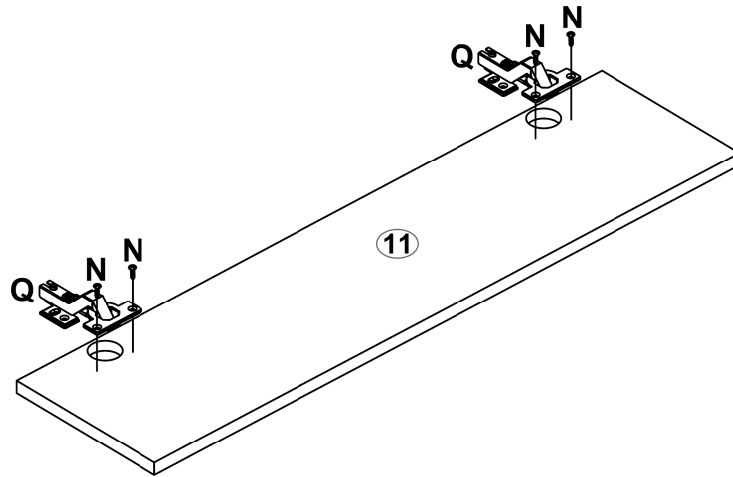

06 -

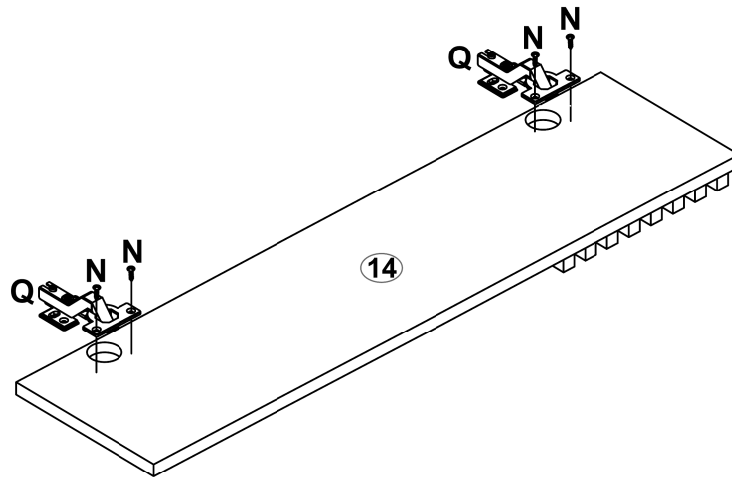

07 -

2x

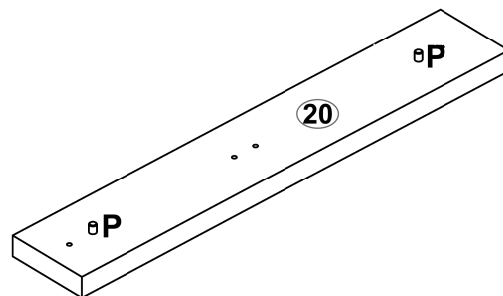

08 -

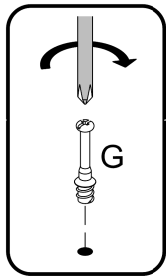

4x

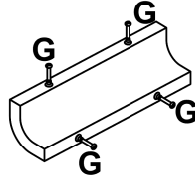

09 -

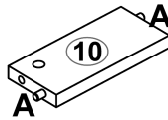
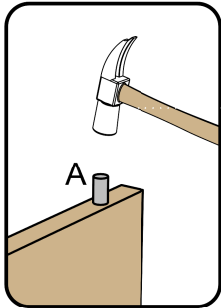

10 -

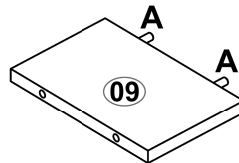
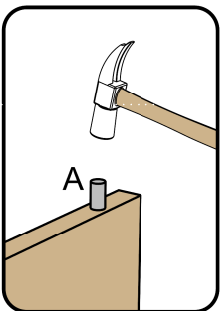

11 -

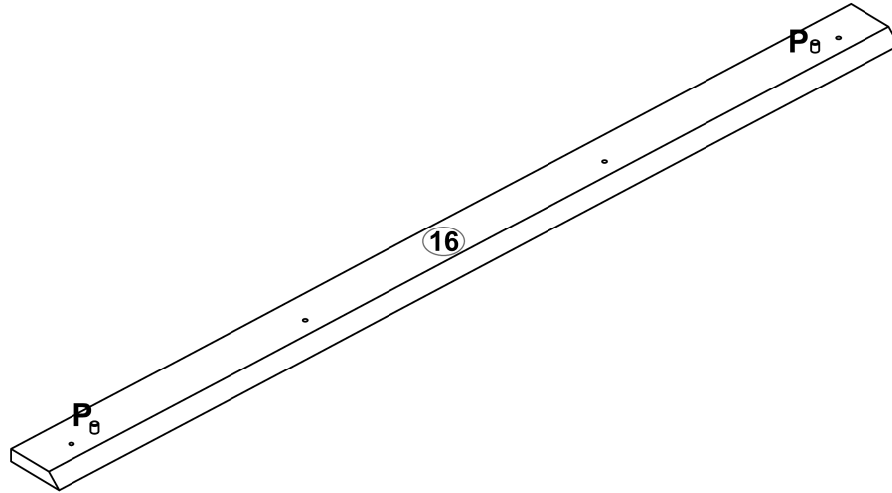

12 -

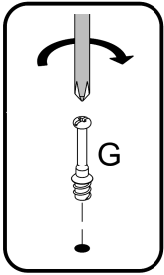

2x

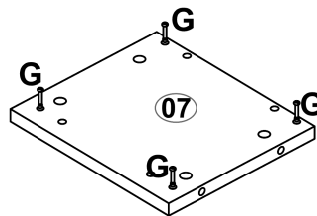

ASSEMBLY - MONTAGE - ARMADO - MONTAGEM

13 -

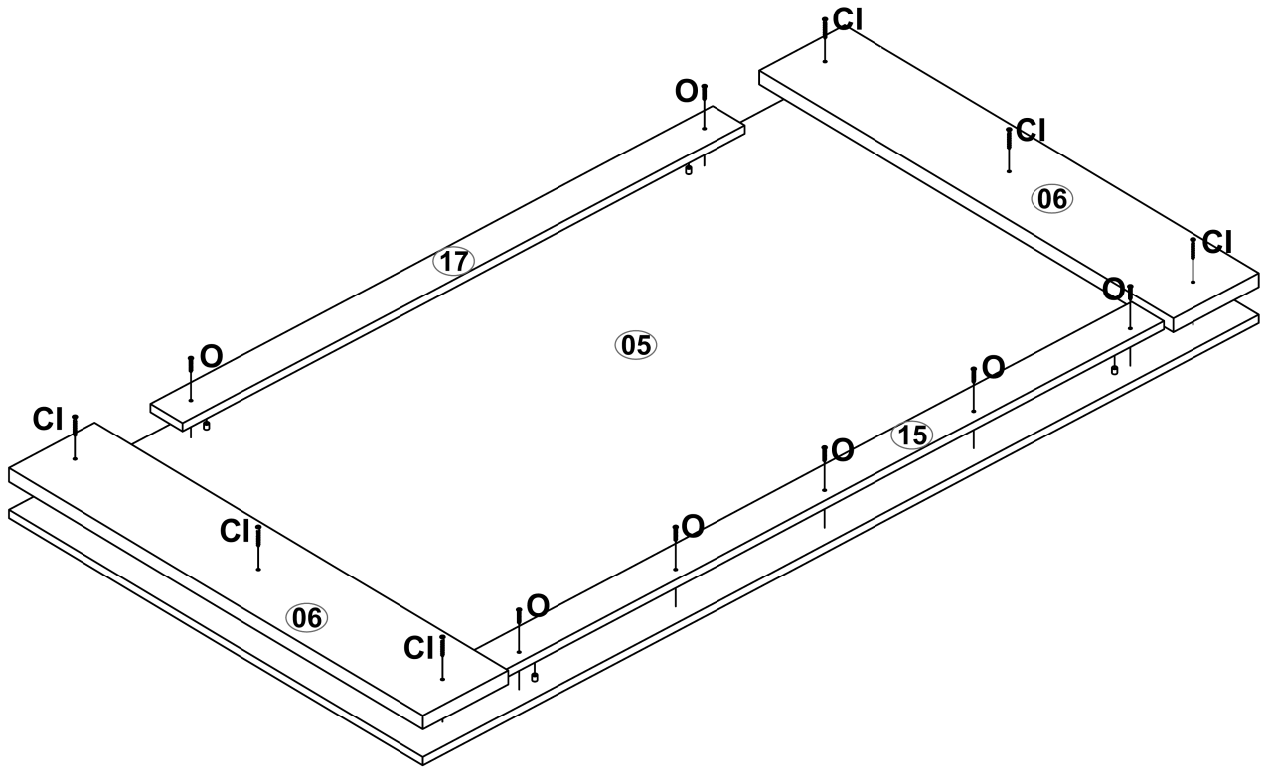

14 -

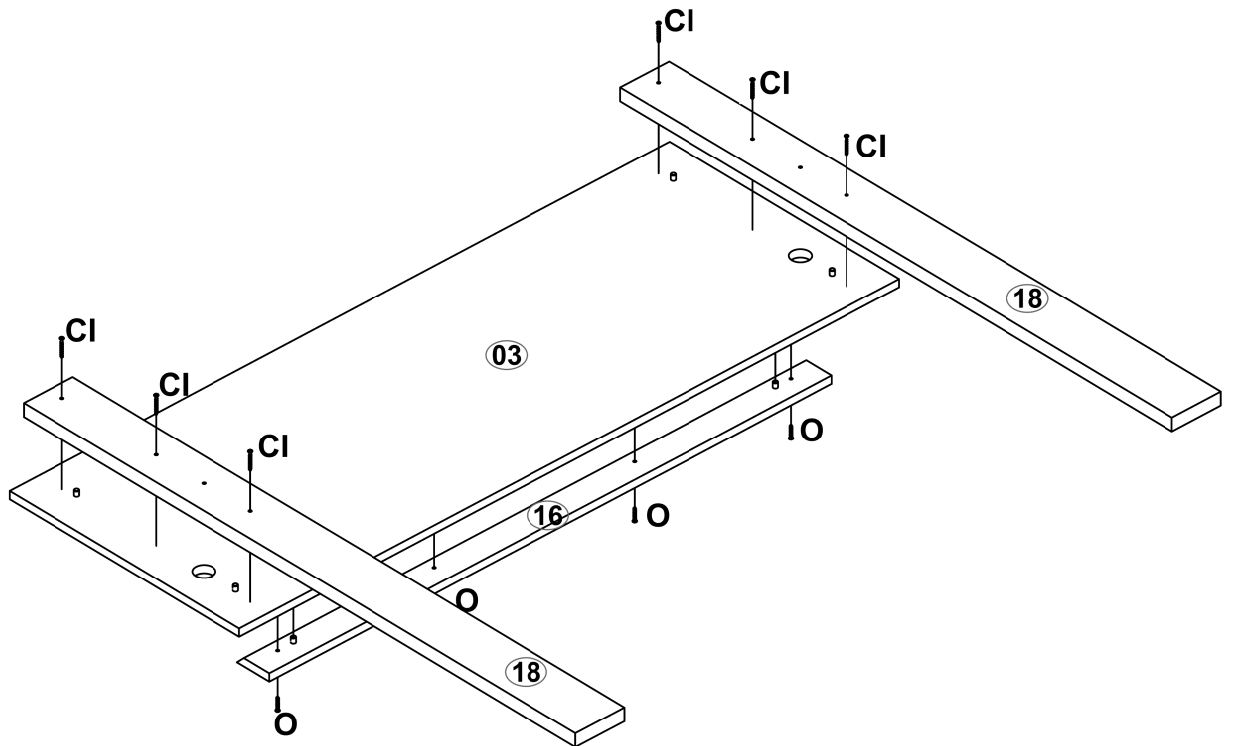



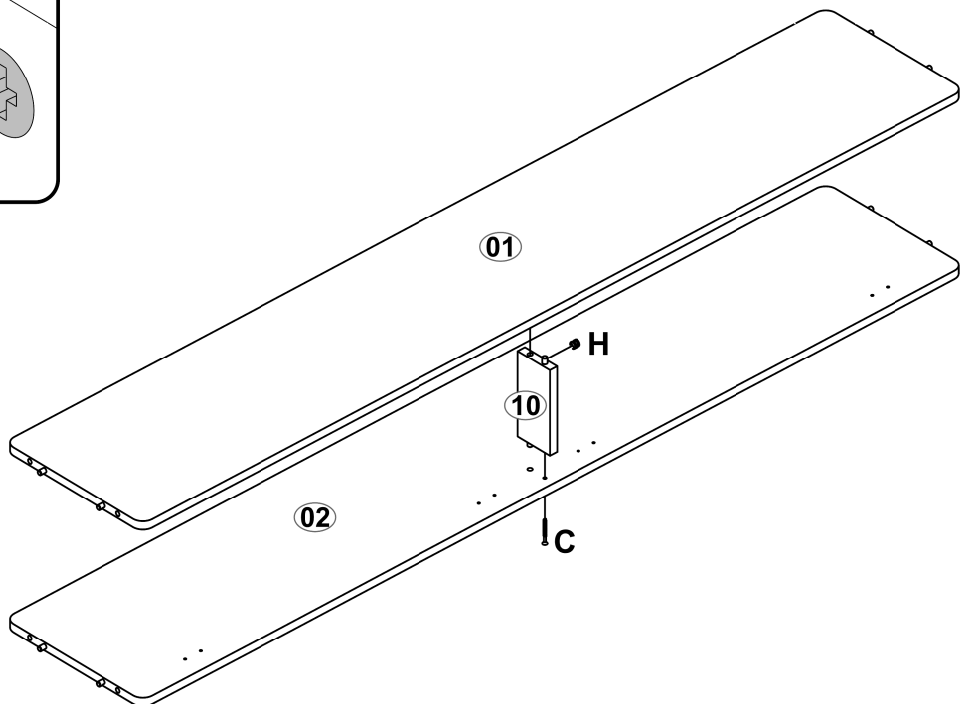
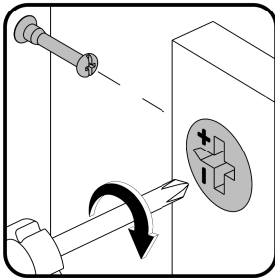
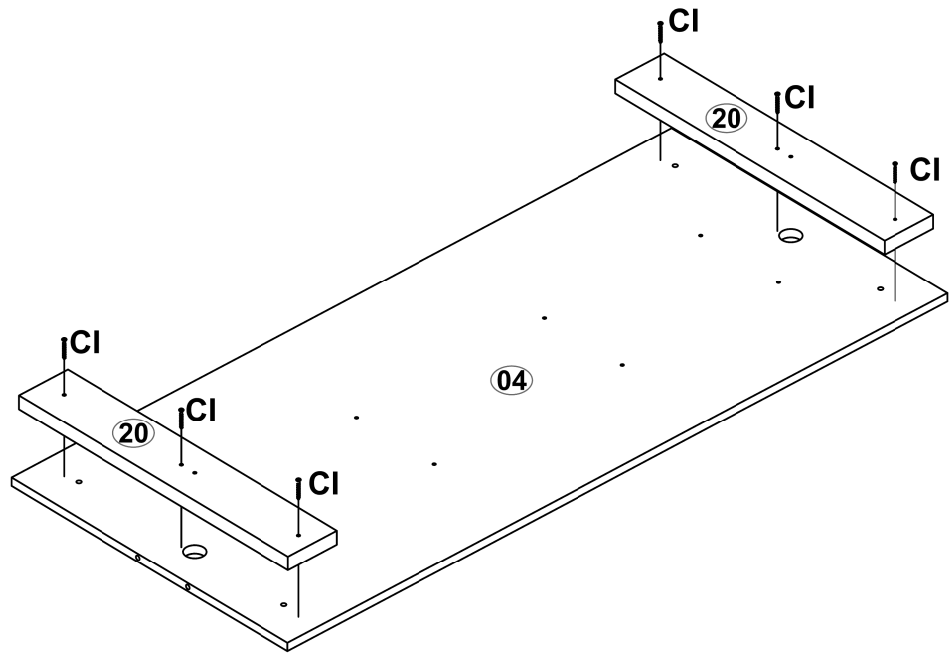

17 -

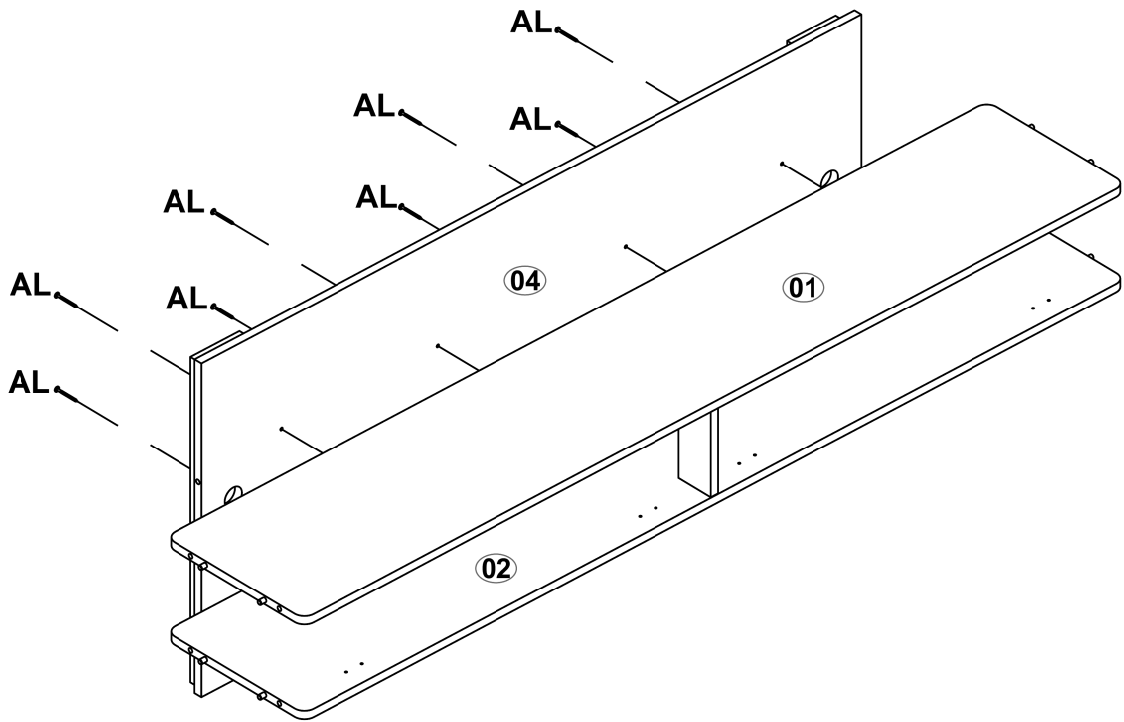

18 -

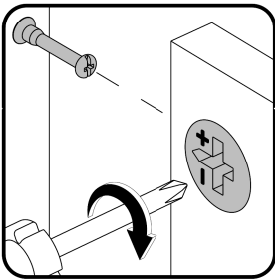

2x

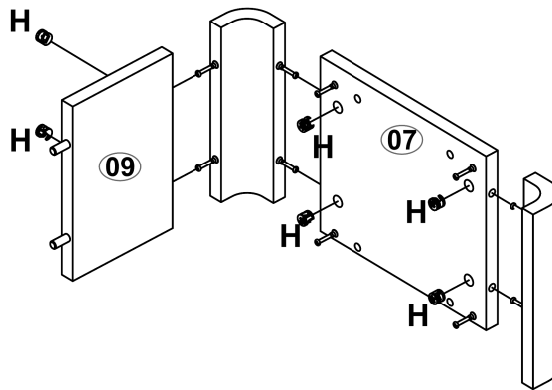

19 -

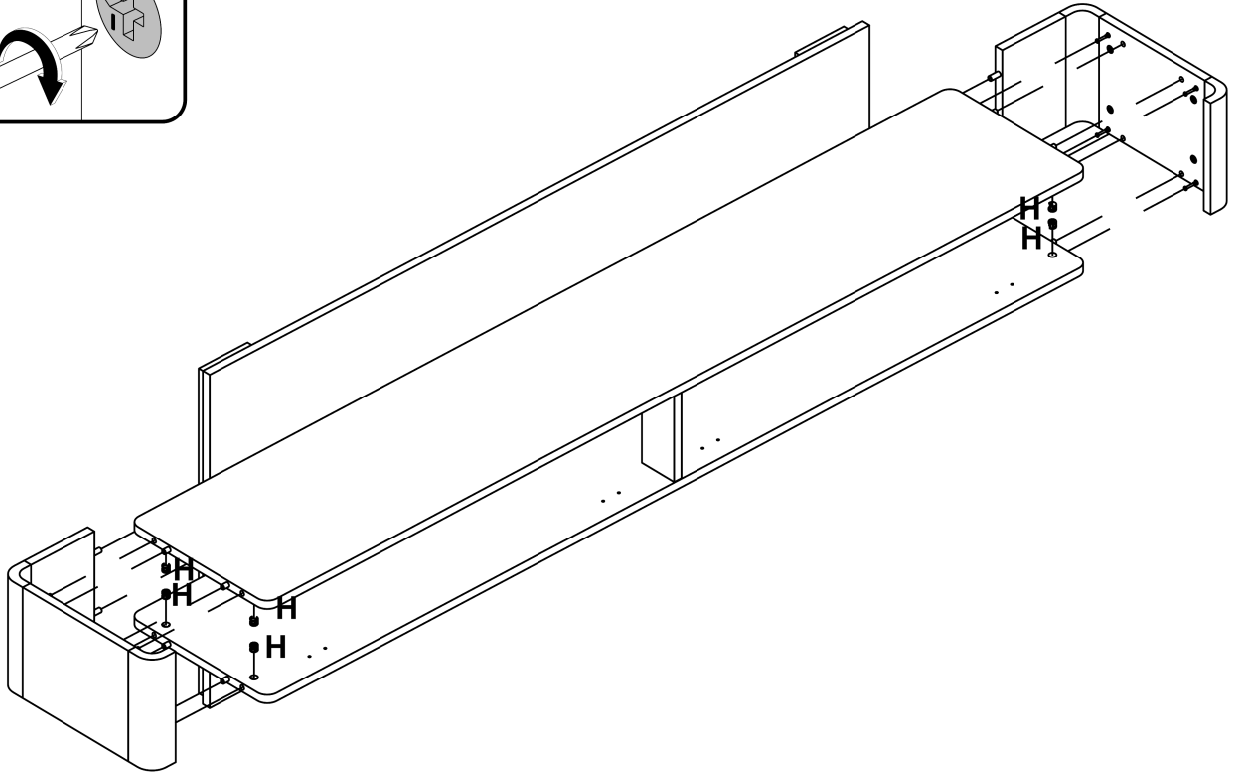
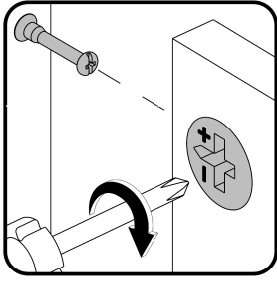

20 -

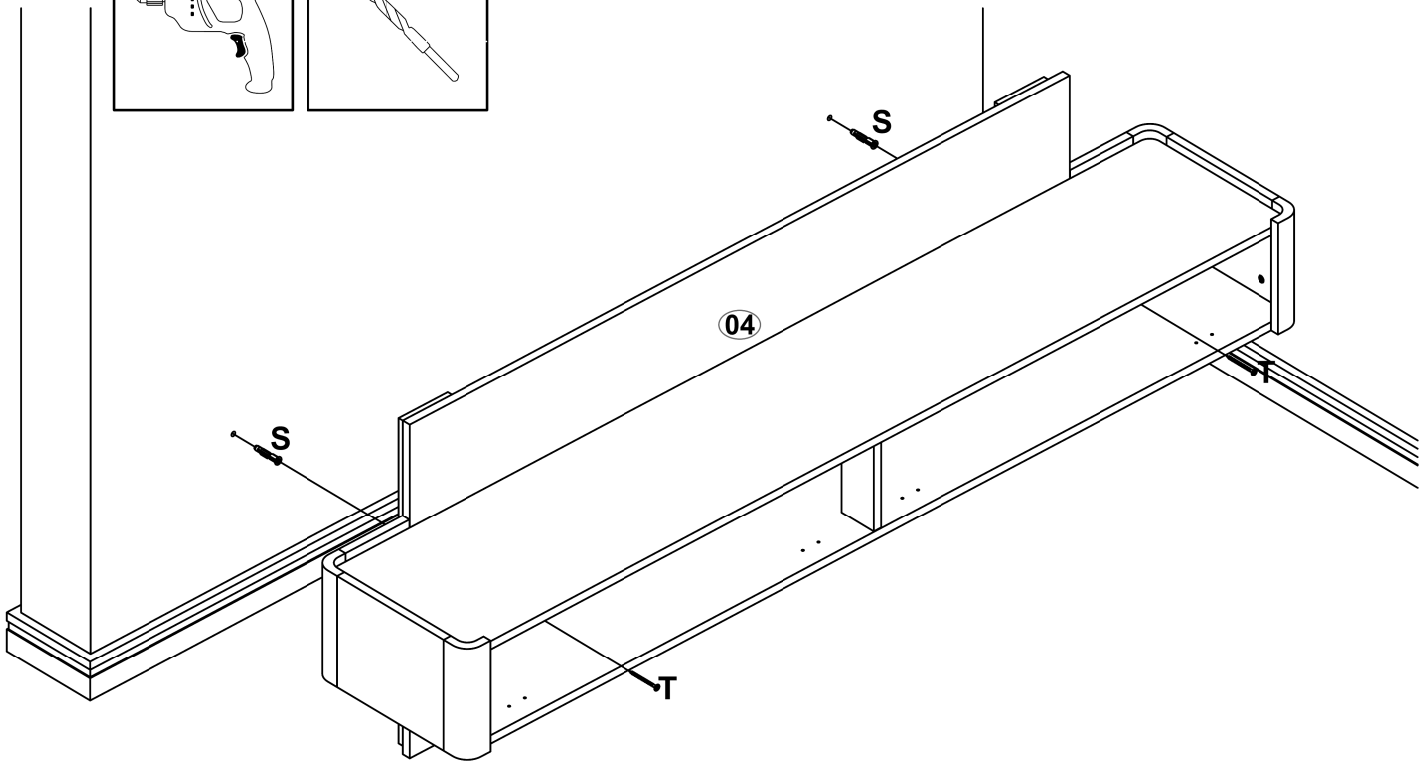
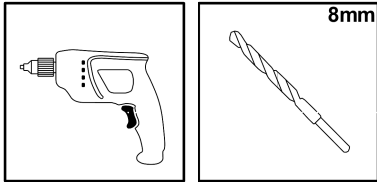

21 -

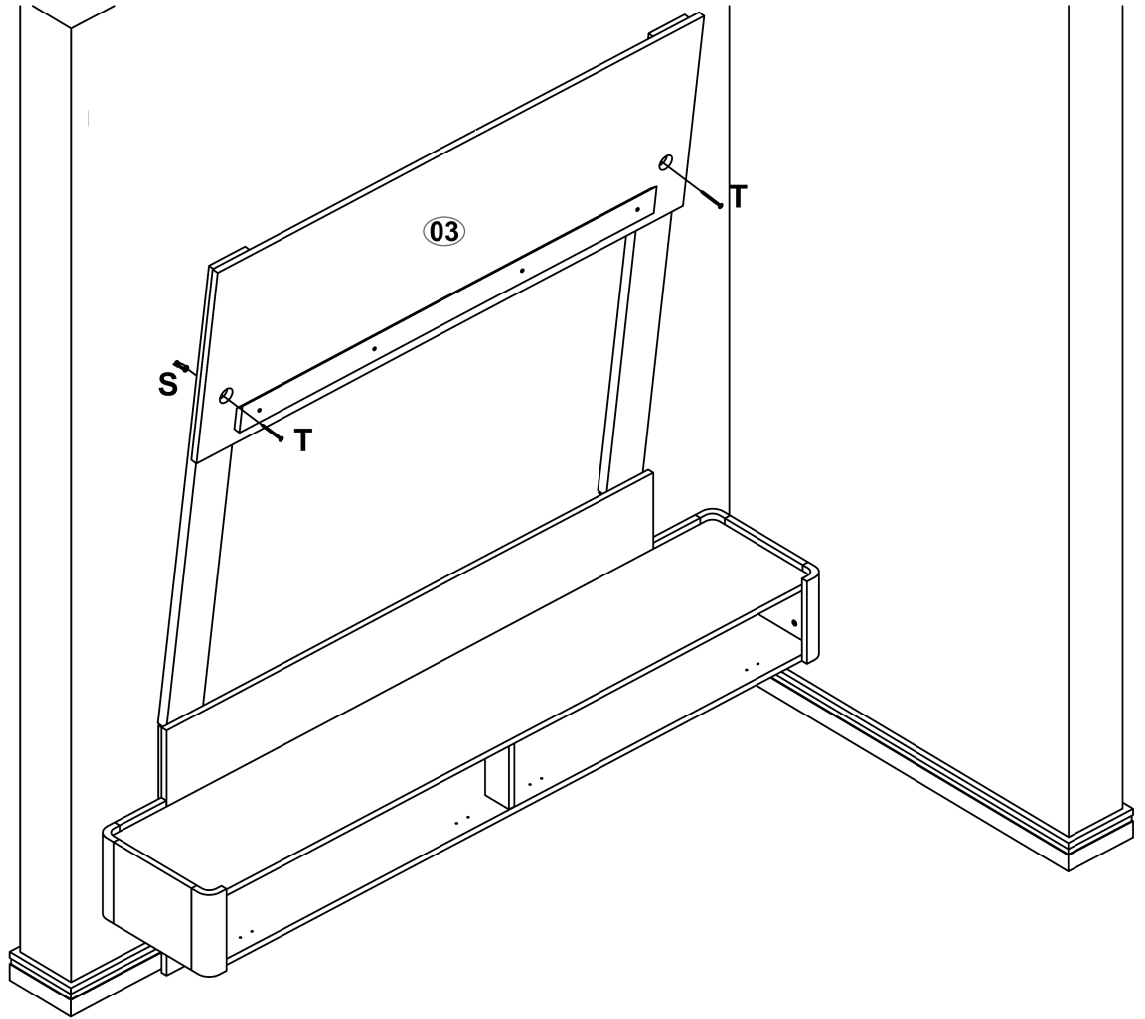
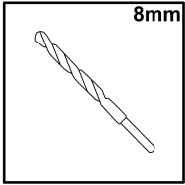
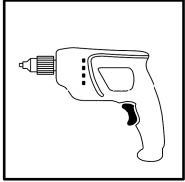

22 -

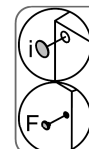
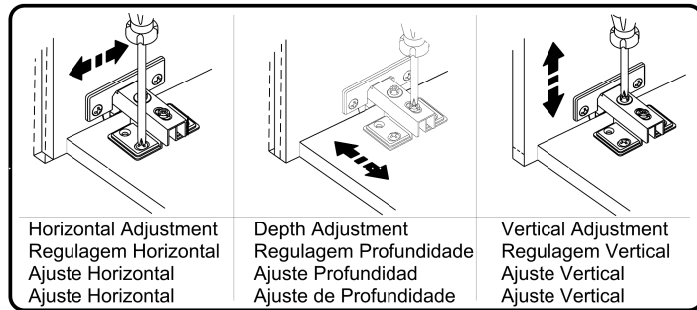
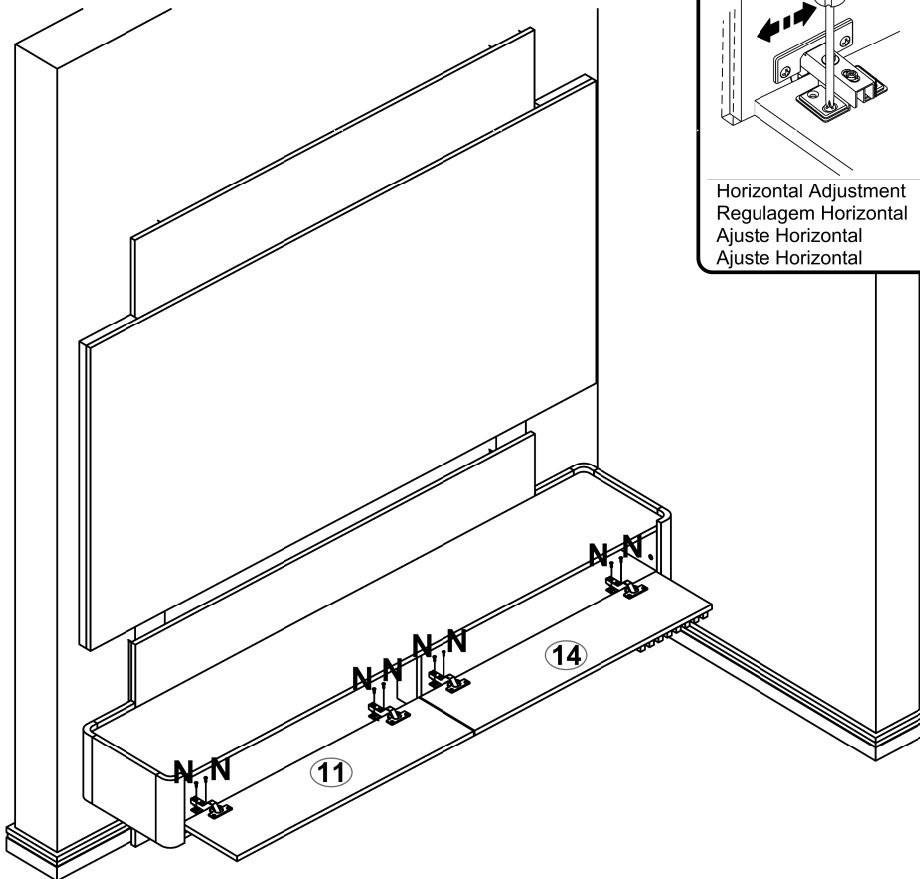

**\*Note:** Use the stickers and caps to finish.  
**\*Remarque:** Utiliser les autocollants et les capuchons pour terminer la finition.  
**\*Nota:** Utilice los adhesivos y tapas para finalizar el acabado.  
**\*Nota:** Utilize os adesivos e tampas para finalizar o acabamento.