

MANUAL DE MONTAGEM

ASSEMBLY INSTRUCTIONS

INSTRUCCIONES DE MONTAJE

NOTICE DE MONTAGE

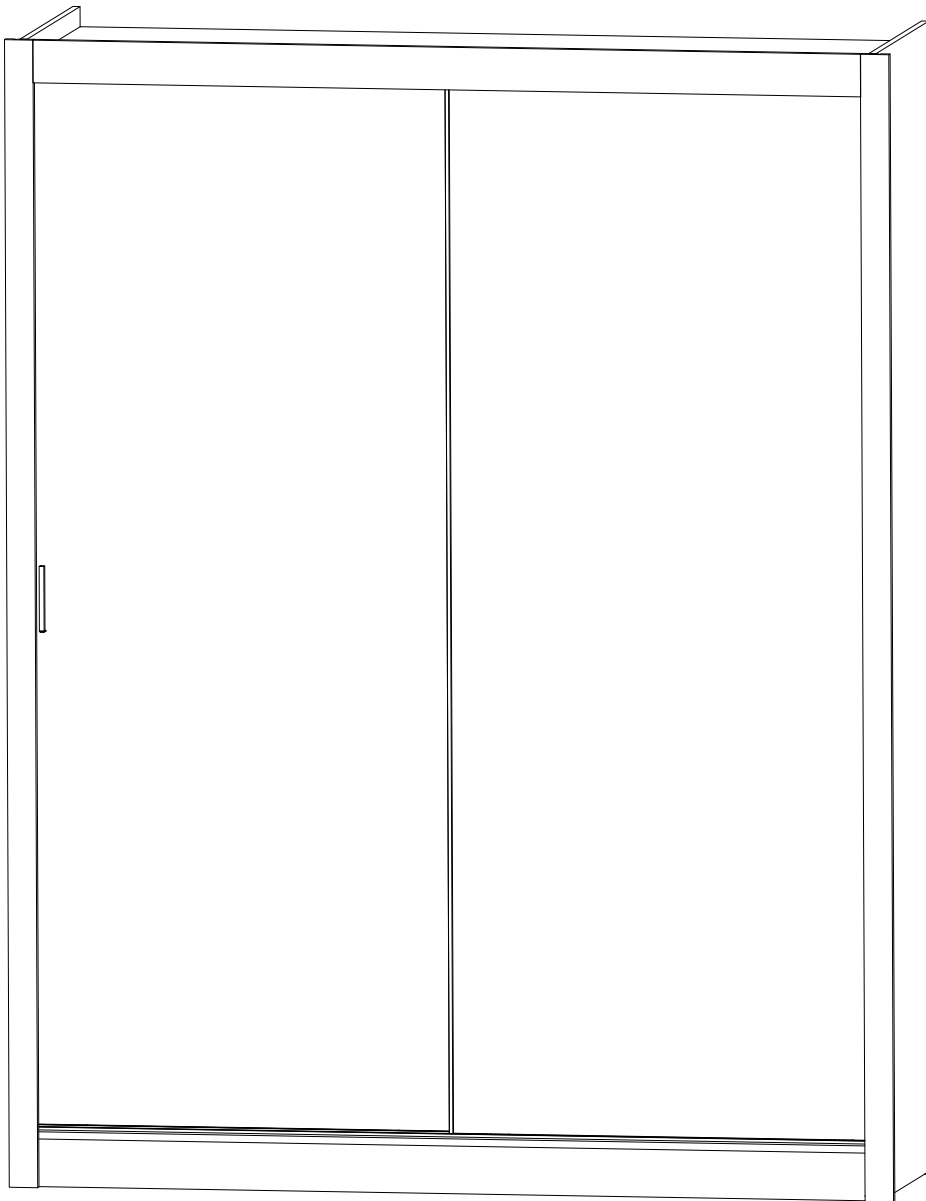

COD: 3000700

REV. 01 - 15/08/24

OBSERVAÇÕES IMPORTANTES IMPORTANT REMARKS OBSERVACIONES IMPORTANTES REMARQUES IMPORTANTES



Nunca escale ou se apoie sobre o móvel. Você pode sofrer graves acidentes.

Never climb or lean on the furniture. You may suffer serious accidents.

Nunca escale o apoie sobre el mobiliario. Usted puede sufrir graves accidentes.

Ne montez jamais sur le meuble. Vous pourriez subir un grave accident.

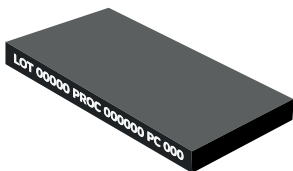

Observe os números impressos nas bordas para identificar as peças.

Identify the parts by observing the number printed on their edges.

Identifique las piezas observando el numero impreso en sus bordes.

Notez les numéros imprimés sur les bords pour identifier les pièces.



Movimente o móvel com cuidado, sem arrastar. Peça ajuda a outra pessoa para fazê-lo.

Move the piece carefully, don't drag it. Ask for someone else's help to do so.

Mover la unidad con cuidado, sin arrastar. Pedir ayuda da otra persona para moverlo.

Déplacez les meubles avec précaution sans le faire glisser. Demandez a quelqu'un de vous aider à le faire.

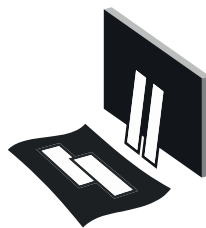

Utilize a embalagem para forrar a área de montagem e separar todas as peças.

Use the packaging to cover the assembly area and separate all parts.

Utilice el embalaje para cubrir la area de montaje y separe las piezas.

Couvrez la zone d'assemblage avec l'emballage pour séparer le pièces.



Limpe com um pano limpo e umedecido em água e sabão neutro. Não utilizar produtos químicos e abrasivos.

Wipe clean using a damp cloth and a mild cleaner. Don't use abrasive and chemical products.

Limpie con un paño limpiohumedecido con agua y jabón neutro. No utilice productos químicos y abrasivos.

Nettoyez avec un chiffon propre imbibé avec d'eau et de savon doux. N'utilisez pas de produits chimiques et abrasifs.



Não colocar objetos em alta temperatura diretamente sobre superfícies de vidro.

Do not place high-temperature objects directly on glass surfaces.

No coloque objetos de alta temperatura directamente sobre superficies de vidro.

Ne placez pas d'objets à haute température directment sur les surfaces en verre.

ACESSÓRIOS HARDWARE HERRAJES ACCESSOIRES

Identifique e separe os acessórios utilizados. Em cada embalagem, uma etiqueta identifica as peças e onde utilizá-las.

Identify and separate the hardware used in the assembly. There's a label on each package identifying the parts and where to use them.

Identifique y separe los accesorios utilizados en el montaje. Observe la etiqueta en cada paquete para saber donde montar.



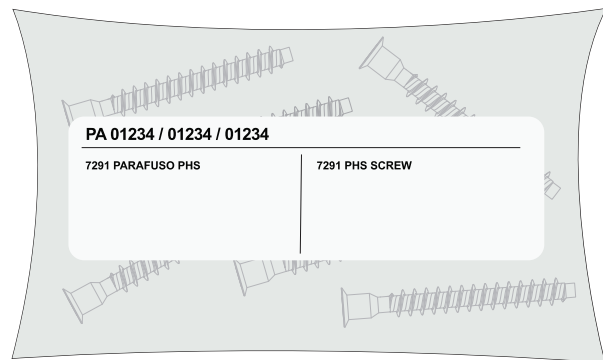





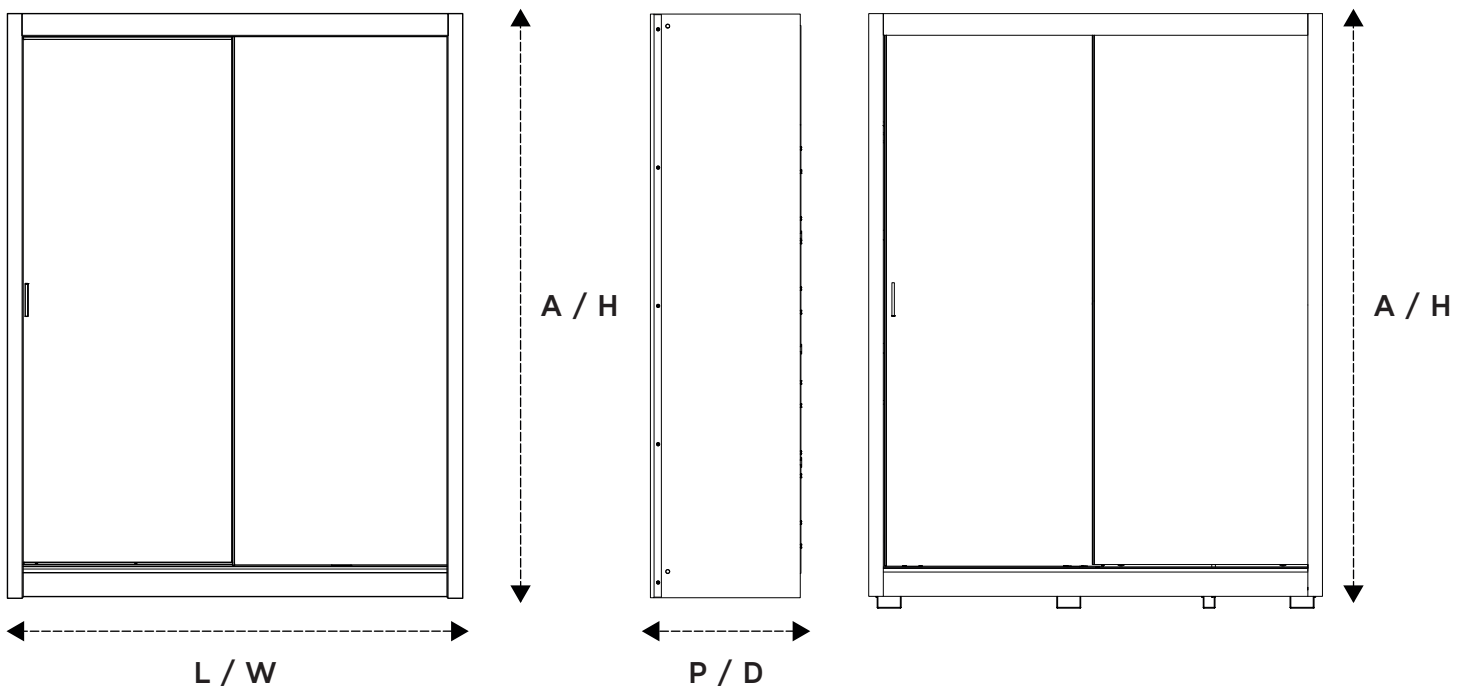

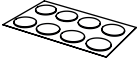



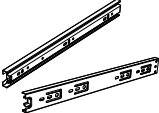





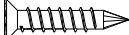
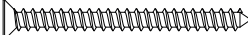
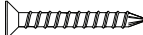
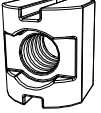
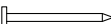

Identifiez et séparez les accessoires à être utilisés. Dans chaque emballage il y a une étiquette pour identifier les pièces et où les utiliser.

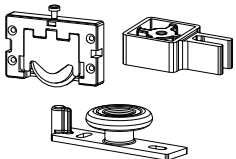

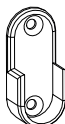
L:1865mm A:2395mm P:618mm
W:73.43in H:94.30in D:24.34in

A:2443mm
H:96.19in

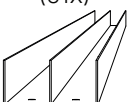

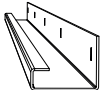
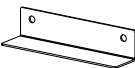
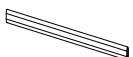
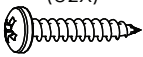
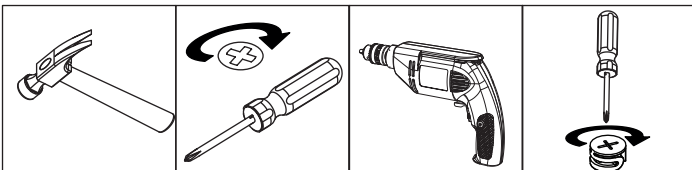
<p>A ADESIVO STICKER ADHESIVO AUTOCOLLANT (50X)</p> 	<p>B PÉ DE PLÁSTICO PLASTIC FOOT PIE DE PLÁSTICO PIED EN PLASTIQUE (07X)</p> 	<p>C COD. 10063 (42X)</p> 	<p>D COD. 1668 6.0 x 30 (94X)</p> 	<p>E COD. 0342 (44X)</p> 
<p>F COD. 4067 (04X)</p> 	<p>G COD. 0714 (06X)</p> 	<p>H COD. 0599 (42X)</p> 	<p>I COD. 16981 1/4 x 2.1/2" (04X)</p> 	<p>J COD. 1533 4.0 x 14 (68X)</p> 
<p>K COD. 3557 4.0 X 14 (70X)</p> 	<p>L COD. 16949 4.0 X 20 (20X)</p> 	<p>M COD. 0715 4.5 x 50 (16X)</p> 	<p>N COD. 0716 5.0 x 25 (10X)</p> 	<p>O COD. 15811 12 x 12 (04X)</p> 
<p>P COD. 0357 10 x 10 (170X)</p> 	<p>Q PUXADOR DOOR HANDLE MANIJA POIGNÉE (01X)</p> 	<p>R COD. 9509 (02X)</p> 	<p>S COD. 0136 (08X)</p> 	<p>T1 / T2 / T3 COD. 17057 (02X)</p> 
<p>U COD. 0602 (05X)</p> 	<p>V COD. 0394 (06X)</p> 	<p>W COD. 0397 (04X)</p> 	<p>X COD. 17032 (01X)</p> 	<p>Y COD. 17022 (01X)</p> 
<p>Z COD. 16905 1774MM (01X)</p> 	<p>AA COD. 16907 1774MM (01X)</p> 	<p>AB COD. CP21718 2193MM (04X)</p> 	<p>AC COD. CP21719 (01X)</p> 	<p>AD COD. 17023 (01X)</p> 
<p>AE COD. 1861 3.5 X 19 (02X)</p> 				

DESCRIÇÃO/ DESCRIPTION/ DESCRIPCIÓN/ DESCRIPTION

COD: 3000700

PEÇA PART PIEZA PIÈCE	QUANTIDADE QUANTITY CANTIDAD QUANTITÉ	DESCRIÇÃO	DESCRIPTION	DESCRIPCIÓN	DESCRIPTION	CAIXA BOX CAJA BOÎTE
01	01	BASE	BASE	BASE	BASE	3
02	01	CHAPÉU	TOP PANEL	PANEL SUPERIOR	PLATEAU	3
03	01	LATERAL ESQUERDA	LEFT SIDE	LATERAL IZQUIERDA	CÔTÉ GAUCHE	2
54	01	LATERAL DIREITA	RIGHT SIDE	LATERAL DERECHA	CÔTÉ DROITE	2
05	01	DIVISÓRIA CENTRAL	CENTER DIVIDER	DIVISION CENTRAL	DIVISEUR CENTRALE	4
81	01	DIVISÓRIA DIREITA	RIGHT DIVIDER	DIVISION DERECHA	DIVISEUR DROITE	4
08	01	PRATELEIRA SUPERIOR	UPPER SHELF	ESTANTE SUPERIOR	ÉTAGÈRE SUPÉRIEURES	3
09	01	TRAVESSA BASE FRONTAL	FRONT BASE CROSSPIECE	TRAVESAÑO BASE FRONTAL	BARREAU BASE	2
11	02	PRATELEIRA CENTRAL SUP.	TOP CENTER SHELF	ESTANTE CENTRAL SUP.	ÉTAGÈRE CENTRALE SUP.	4
12	01	PRATELEIRA CENTRAL INF.	LOWER CENTER SHELF	ESTANTE CENTRAL INF.	ÉTAGÈRE CENTRALE INF.	2
13	01	DIVISÓRIA SUPERIOR	UPPER DIVISION	DIVISOR SUPERIOR	DIVISEUR SUPÉRIEUR	2
14	02	PORTA LATERAL	SIDE DOOR	PUERTA LATERAL	PORTE CÔTÉ	1
16	04	FUNDO ESQUERDA	LEFT BACKPLATE	FONDO IZQUIERDA	FOND GAUCHE	1
18	01	FUNDO SUPERIOR	UPPER BACKPLATE	FONDO SUPERIOR	FOND SUPÉRIEURES	4
19	01	TRAVESSA BASE TRASEIRA	BACK BASE CROSSPIECE	TRAVESAÑO BASE TRASERA	BARREAU BASE	2
20	01	TRAVESSA SUPERIOR	UPPER CROSSPIECE	TRAVESAÑO SUPERIOR	BARREAU INFÉRIEURES	2
21	01	DISTANCIADOR FRONTAL	DISTANCER	DISTANCIADOR	DISTANCEUR	2
23	01	DISTANCIADOR TRASEIRO	DISTANCER	DISTANCIADOR	DISTANCEUR	2
25	02	SARRAFO LATERAL	SIDE BATTEN	SARRAFO LATERAL	LATTE LATÉRALE	2
26	02	SARRAFO REFORÇO	BATTEN	SARRAFO	LATTE	2
27	04	TRAVESSA BASE	BASE CROSSPIECE	TRAVESAÑO BASE	BARREAU BASE	2
28	01	PORTA CENTRAL	CENTER DOOR	PUERTA CENTRAL	PORTE CENTRALE	1
32	03	PERFIL H ESQUERDA	LEFT H-PROFILE	PERFIL EN H IZQUIERDA	PROFILÉ EN H GAUCHE	2
33	01	PRATELEIRA ESQUERDA	LEFT TOP SHELF	ESTANTE IZQUIERDA	ÉTAGÈRE GAUCHE	5
35	04	FUNDO DIREITA	RIGHT BACKPLATE	FONDO DERECHA	FOND DROITE	1
36	03	PERFIL H DIREITA	RIGHT H-PROFILE	PERFIL EN H DERECHA	PROFILÉ EN H DROITE	2
37	01	PRATELEIRA DIREITA	RIGHT TOP SHELF	ESTANTE DERECHA	ÉTAGÈRE DROITE	4
60	04	FRENTE GAVETA	DRAWER FRONT	FRENTE DEL CAJÓN	FAÇADE DE TIROIR	5
61	04	LATERAL GAVETA ESQ.	LEFT DRAWER SIDE	CAJÓN LATERAL IZQ.	CÔTÉ DE TIROIR	2
62	04	LATERAL GAVETA DIR.	RIGHT DRAWER SIDE	CAJÓN LATERAL DER.	CÔTÉ DE TIROIR	2
63	04	CONTRA FUNDO	DRAWER BACK PANEL	CAJÓN INFERIOR	DERRIÈRE	5
64	04	FUNDO GAVETA	DRAWER BOTTOM	FONDO DEL CAJÓN	FOND DE TIROIR	5
65	04	TRAVESSA GAVETA	DRAWER CROSSPIECE	TRAVESAÑO CAJÓN	BARREAU	2

MONTAGEM NECESSITA 2 PESSOAS
ASSEMBLY REQUIRES 2 PEOPLE
EL MONTAJE NECESITA 2 PERSONAS
MONTAGE A 2 PERSONNES



O PRODUTO ESPELHO **AF - 04X (PA5100300)** É OPCIONAL. *VENDIDO SEPARADAMENTE
THIS IS ADD-ON ITEM MIRROR **AF - 04X (PA5100300)**. *SOLD SEPARATELY.
EL ACCESORIO ESPEJO **AF - 04X (PA5100300)** ES OPCIONAL. *SE VENDE EN SEPARADO.
LE PRODUIT MIROIR **AF - 04X (PA5100300)** EST OPTIONNEL. *VENDU SÉPAREMENT.

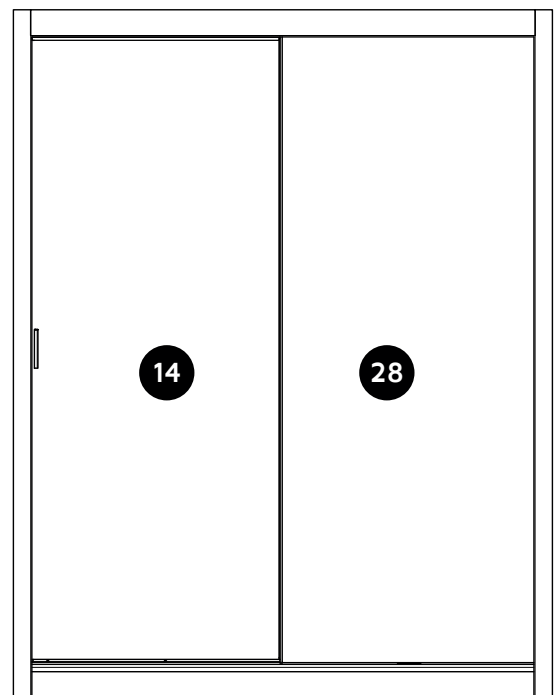
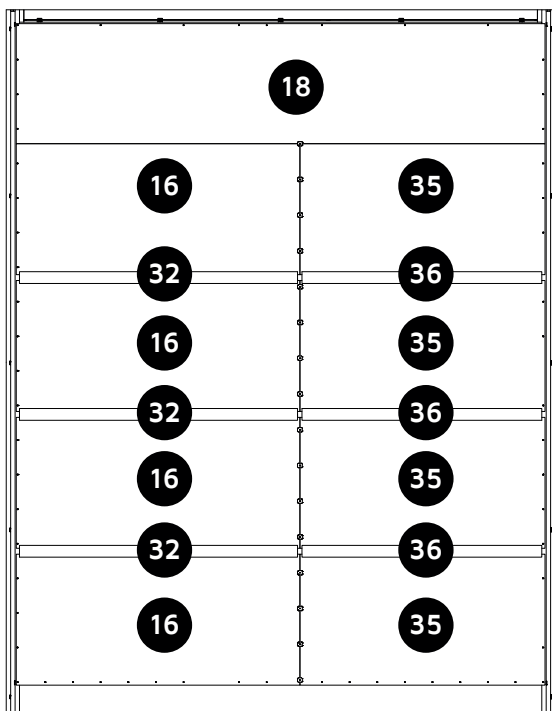

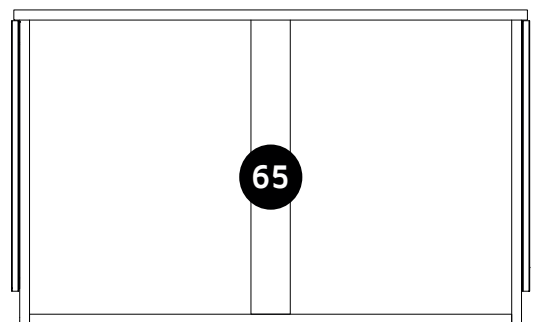
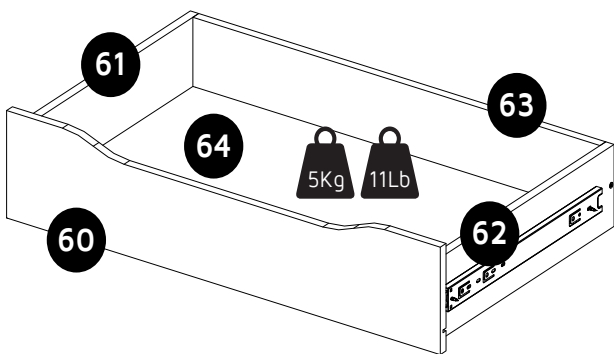
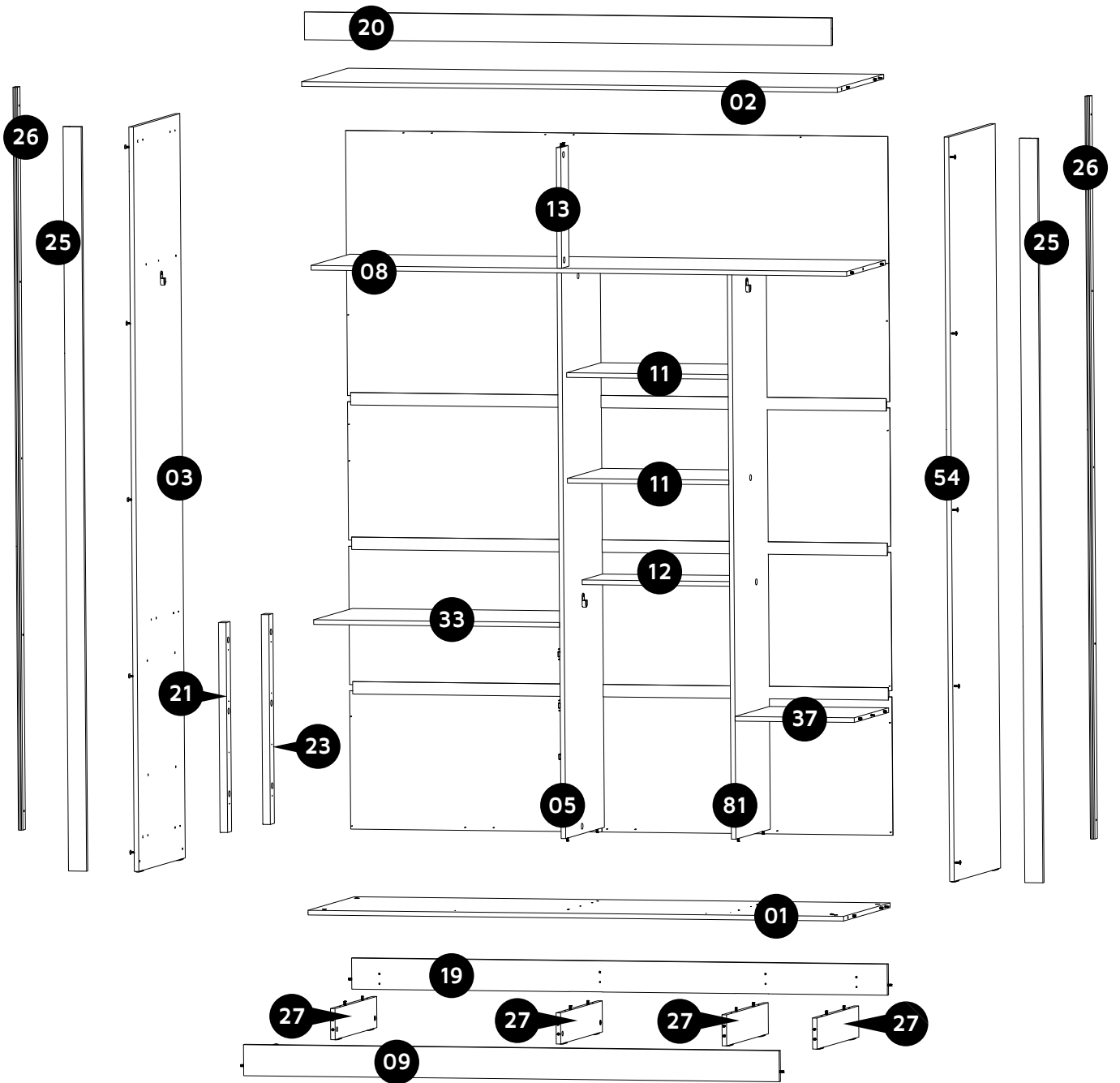

01

A 	C COD. 10063 	D COD. 1668 	H COD. 0599 	J COD. 1533 	M COD. 0715 	V COD. 0394 
---	---	--	---	--	--	--

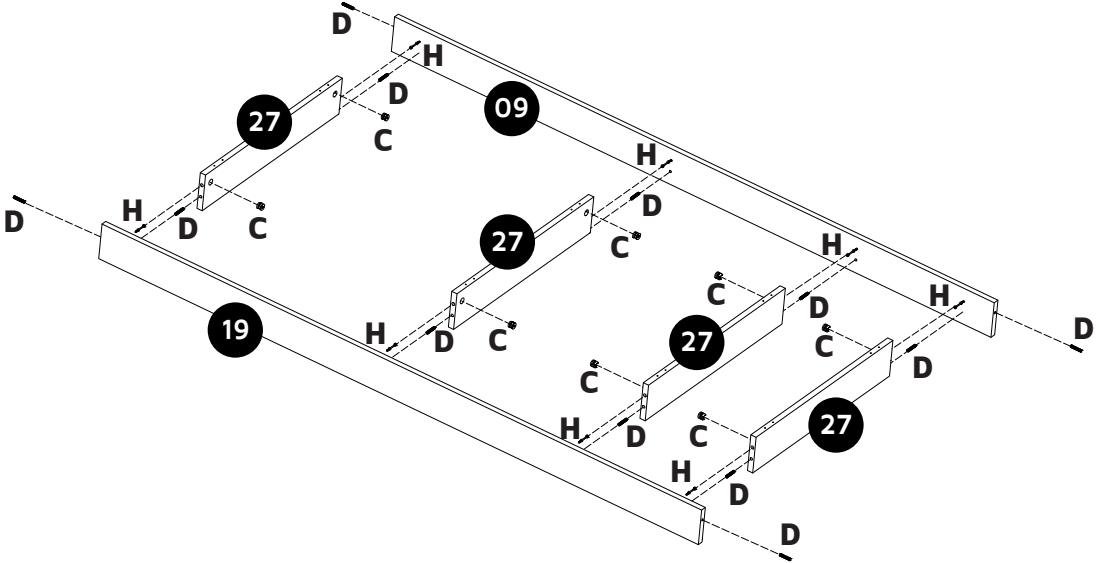



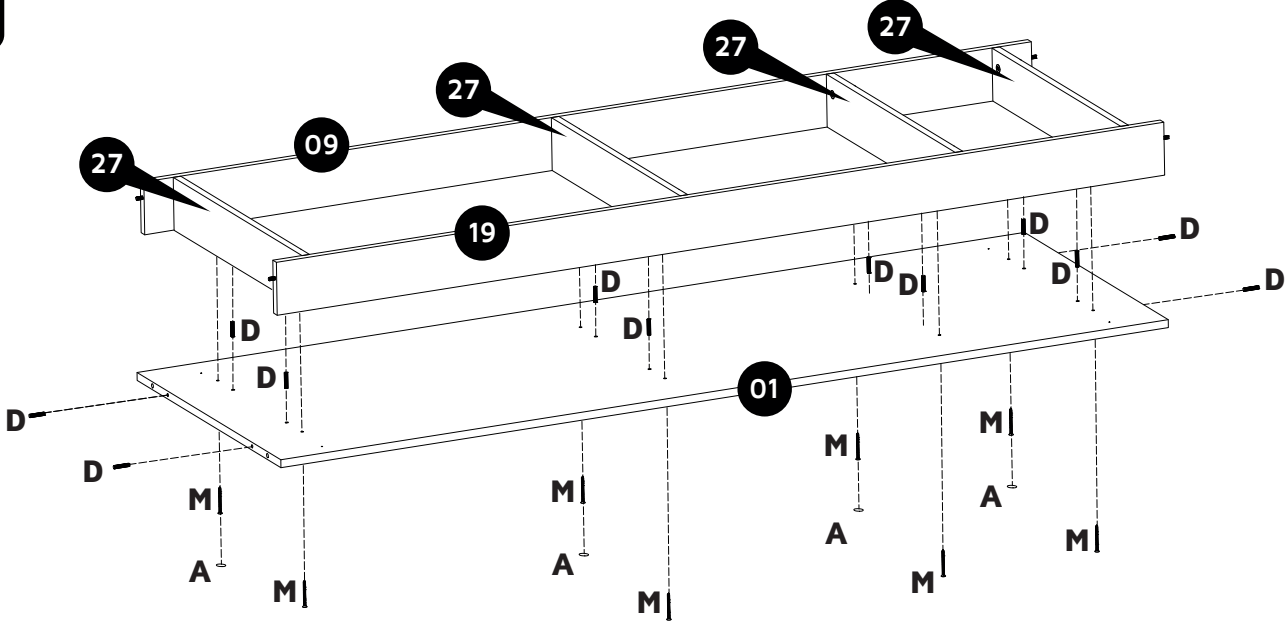

02

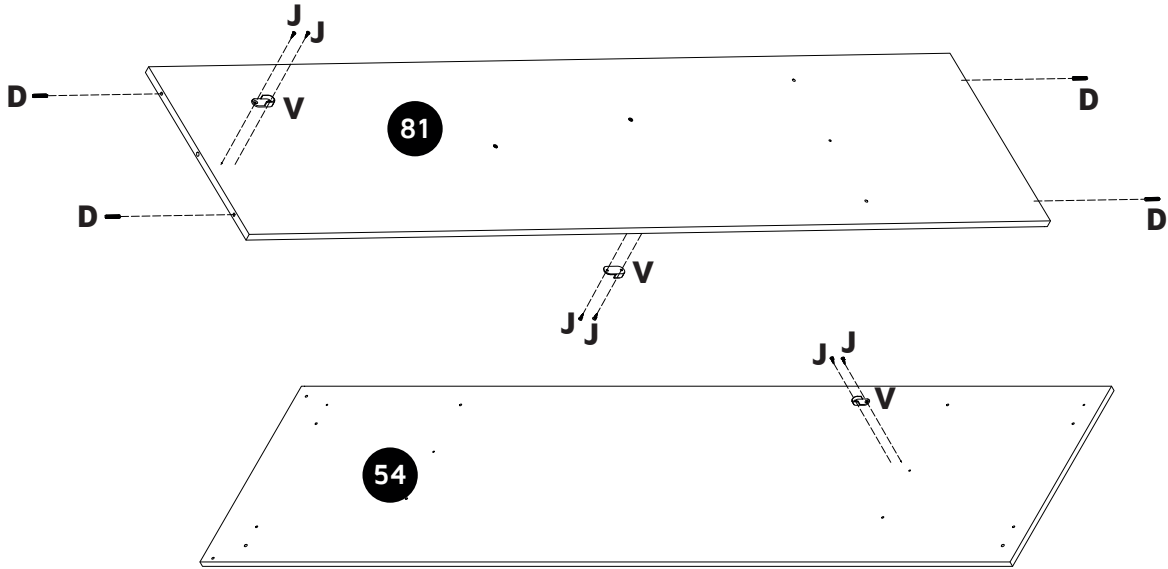

03



04

B 	J COD. 1533 	K COD. 3557 	S COD. 0136 
---	--	--	--

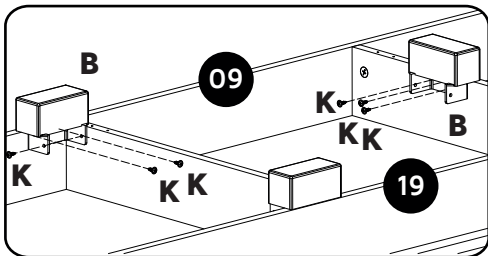

O PÉ (B - MP17122) É OPCIONAL. SE UTILIZAR O MESMO, PULE AS ETAPAS 05 e 06.
 THE FOOT (B - MP17122) IS OPTIONAL. IF YOU USE THE SAME, SKIP STEPS 05 and 06.
 EL PIE (B - MP17122) ES OPCIONAL. SI UTILIZA EL MISMO, SALTE LOS PASOS 05 y 06.
 LE PIED (B - MP17122) EST OPTIONNEL. SI VOUS UTILISEZ, SAUTEZ LES ÉTAPES 05 et 06.

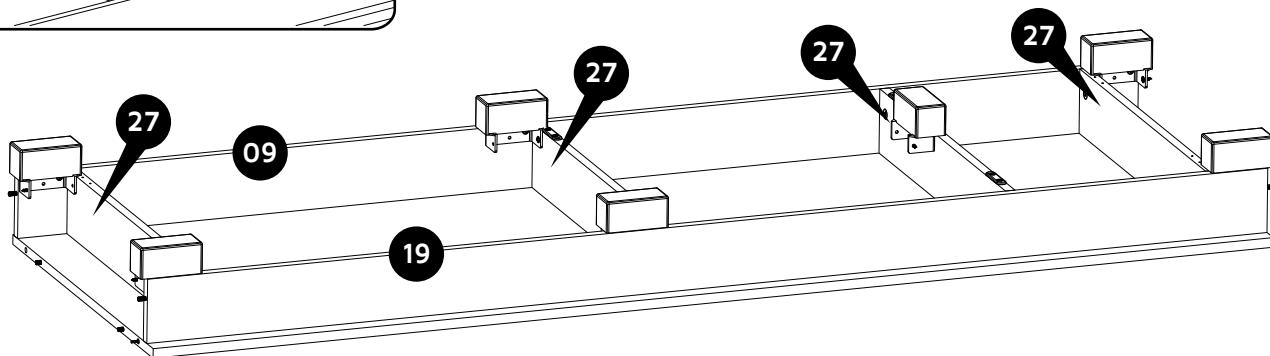

05





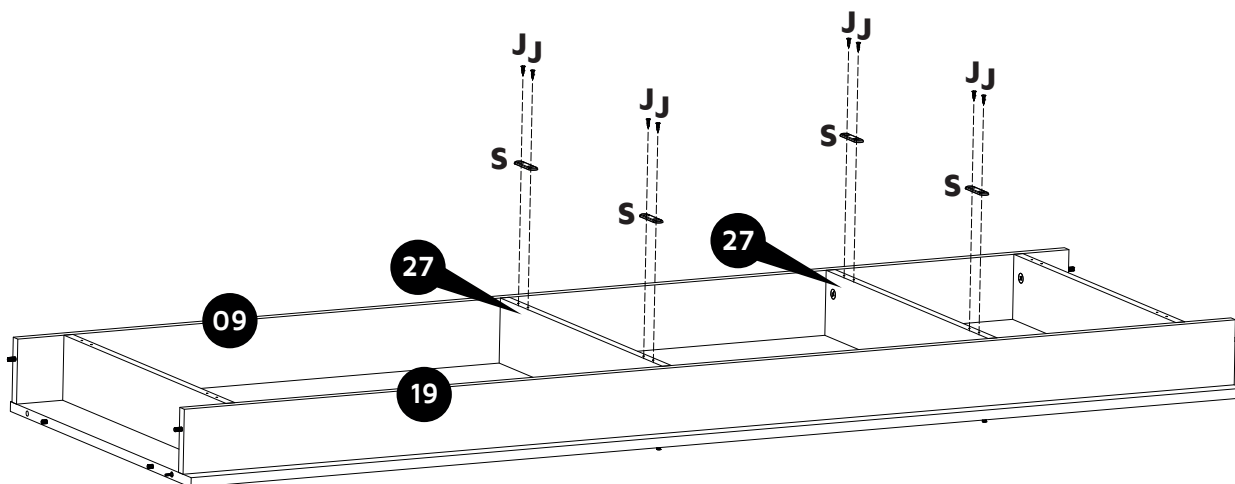



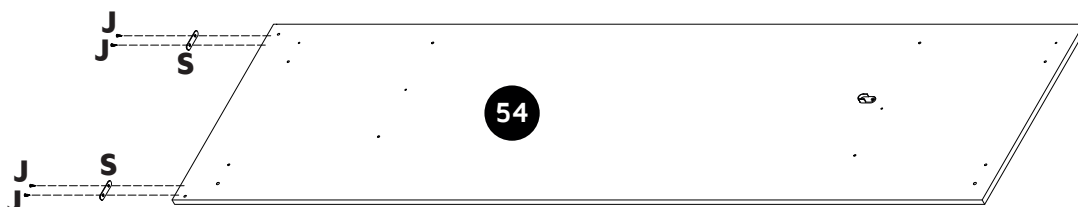
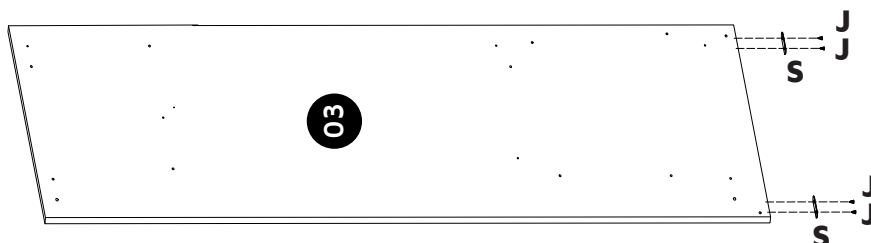

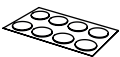

SE NÃO UTILIZAR O PÉ (B - MP17122), PULE A ETAPA 04. SIGA AS ETAPAS 05 e 06.
 IF YOU DO NOT USE THE FOOT (B - MP17122), SKIP STEP 04. FOLLOW STEPS 05 and 06.
 SI NO UTILIZA EL PIE (B - MP17122), SALTE EL PASO 04. SIGA LOS PASOS 05 y 06.
 SI VOUS N'UTILISEZ PAS LE PIED (B - MP17122), SAUTEZ LE ÉTAPE 04. SUIVEZ LES ÉTAPES 05 et 06.



06



07

A 	C COD. 10063 	D COD. 1668 	F COD. 4067 	G COD. 0714 	H COD. 0599 	I COD. 16981 	J COD. 1533 	V COD. 0394 	W COD. 0397 
---	---	--	--	--	--	--	--	--	--



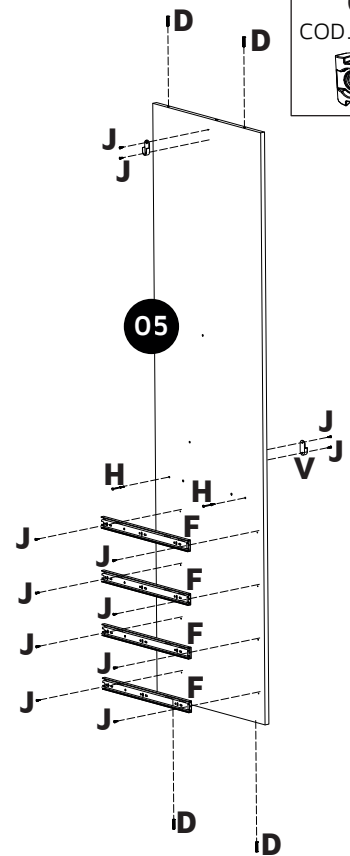
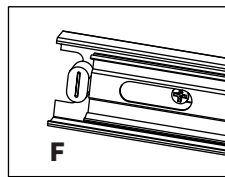
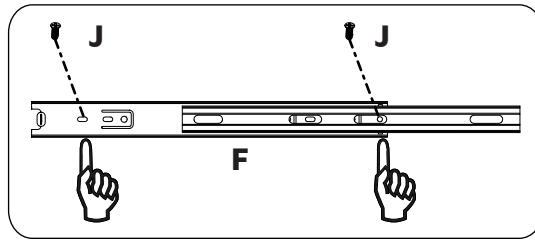
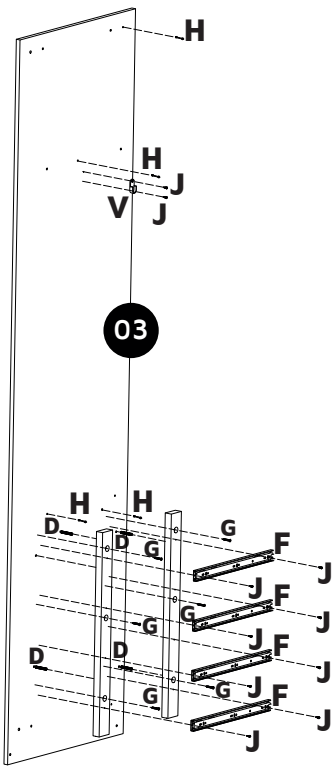

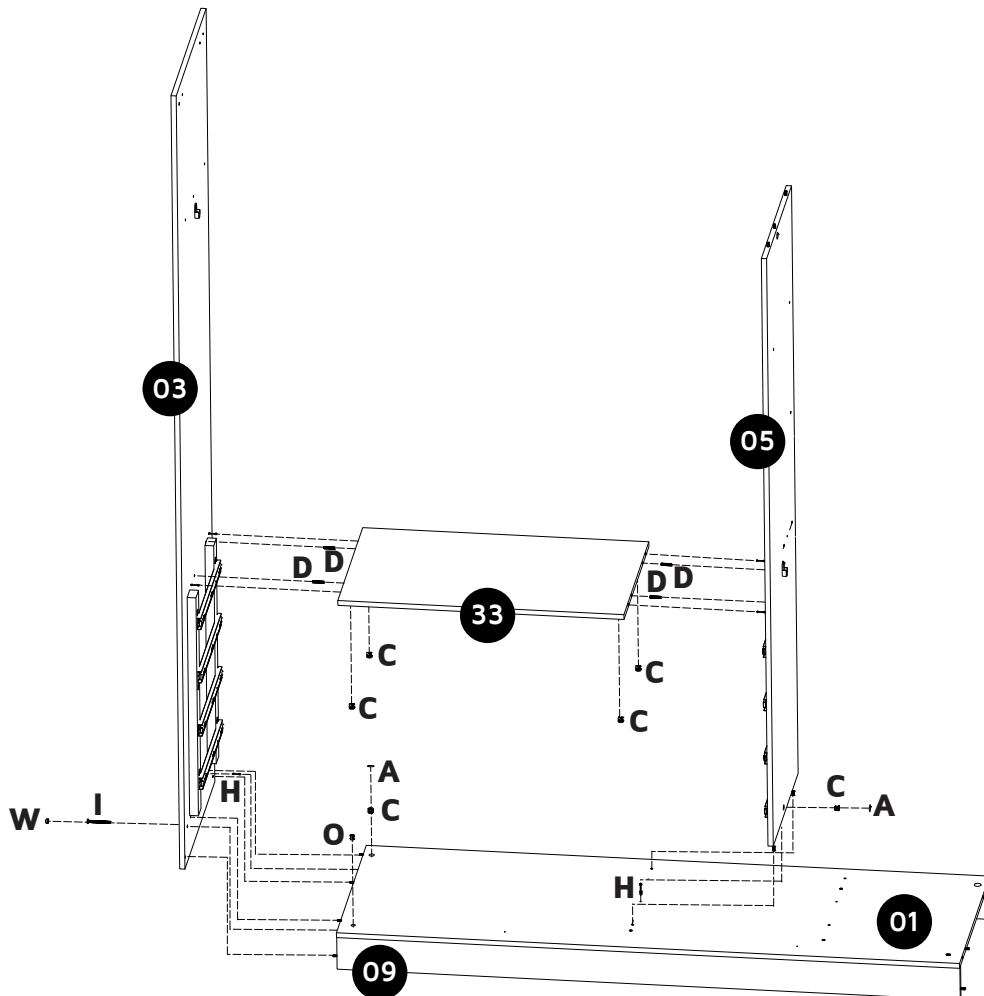

O
COD. 15811



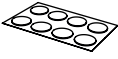

08

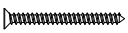

09

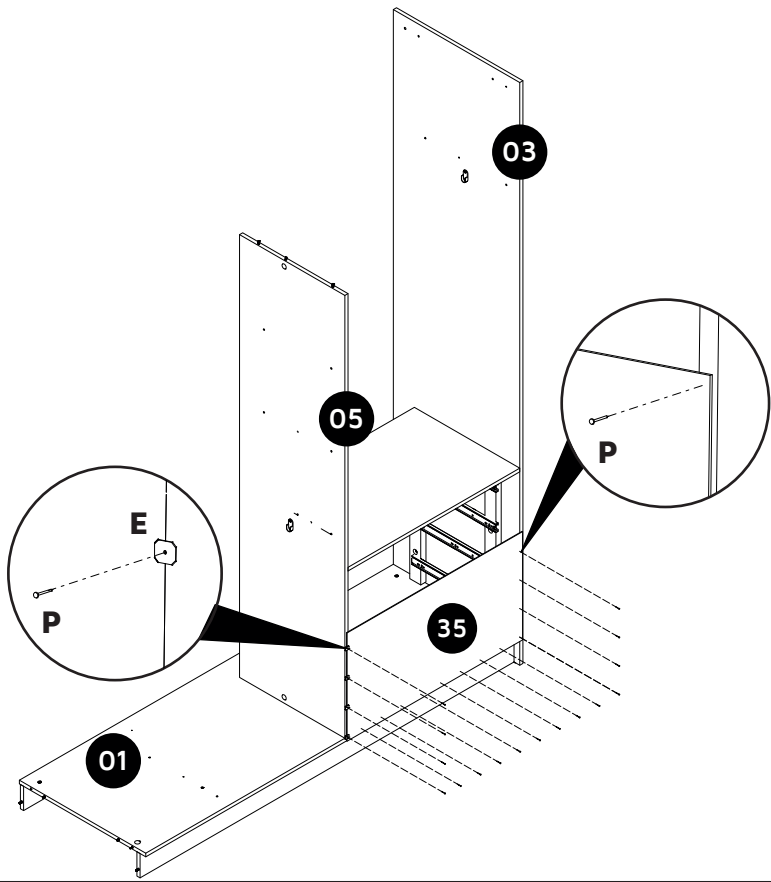
A 	C COD. 10063 	D COD. 1668 	E COD. 0342 	H COD. 0599 	M COD. 0715 	P COD. 0357 
---	---	--	--	--	--	--



10

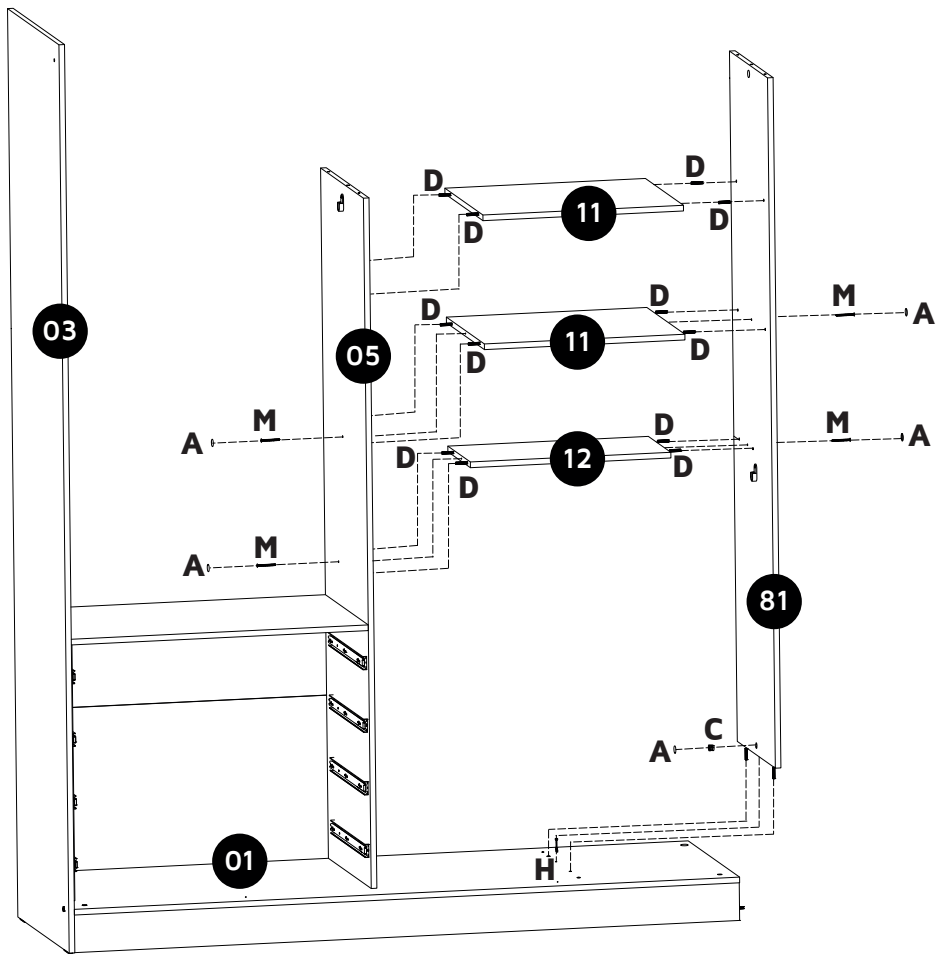

11



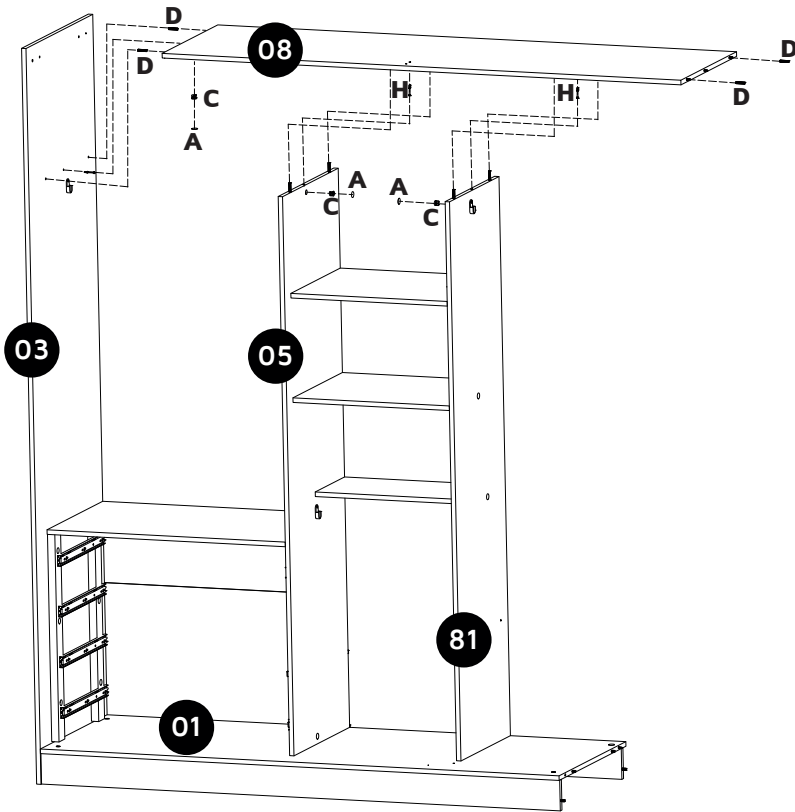



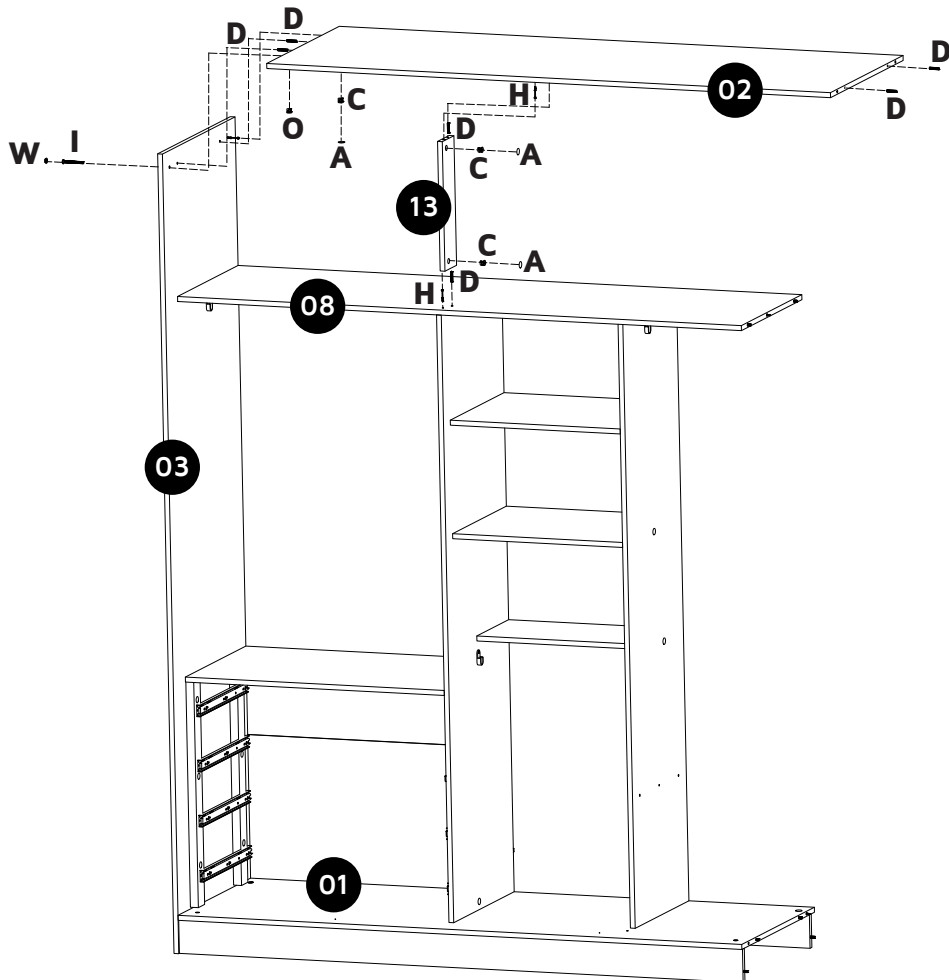

A 	C COD. 10063 	D COD. 1668 	H COD. 0599 	M COD. 0715 	O COD. 15811 	W COD. 0397
--------------	----------------------------	---------------------------	---------------------------	---------------------------	----------------------------	---------------------------

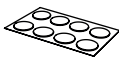

12



13

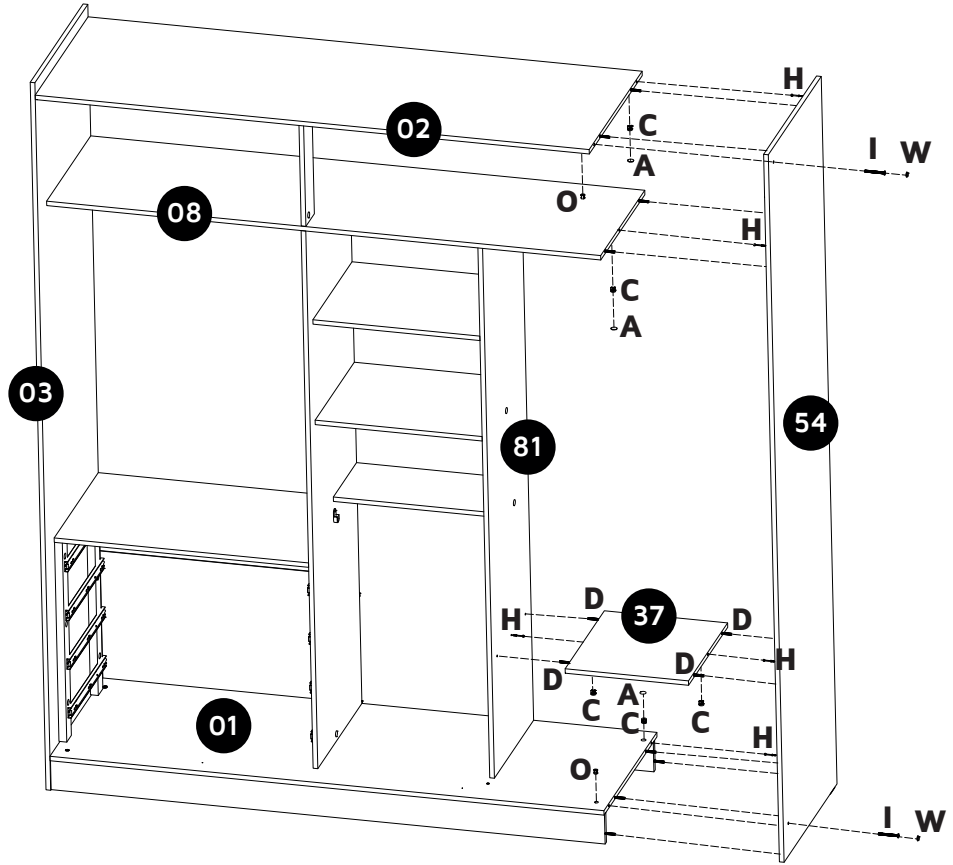

A 	C COD. 10063 	D COD. 1668 	E COD. 0342 	H COD. 0599 	I COD. 16981 	O COD. 15811 	P COD. 0357 	W COD. 0397 
---	---	--	--	--	--	---	--	--

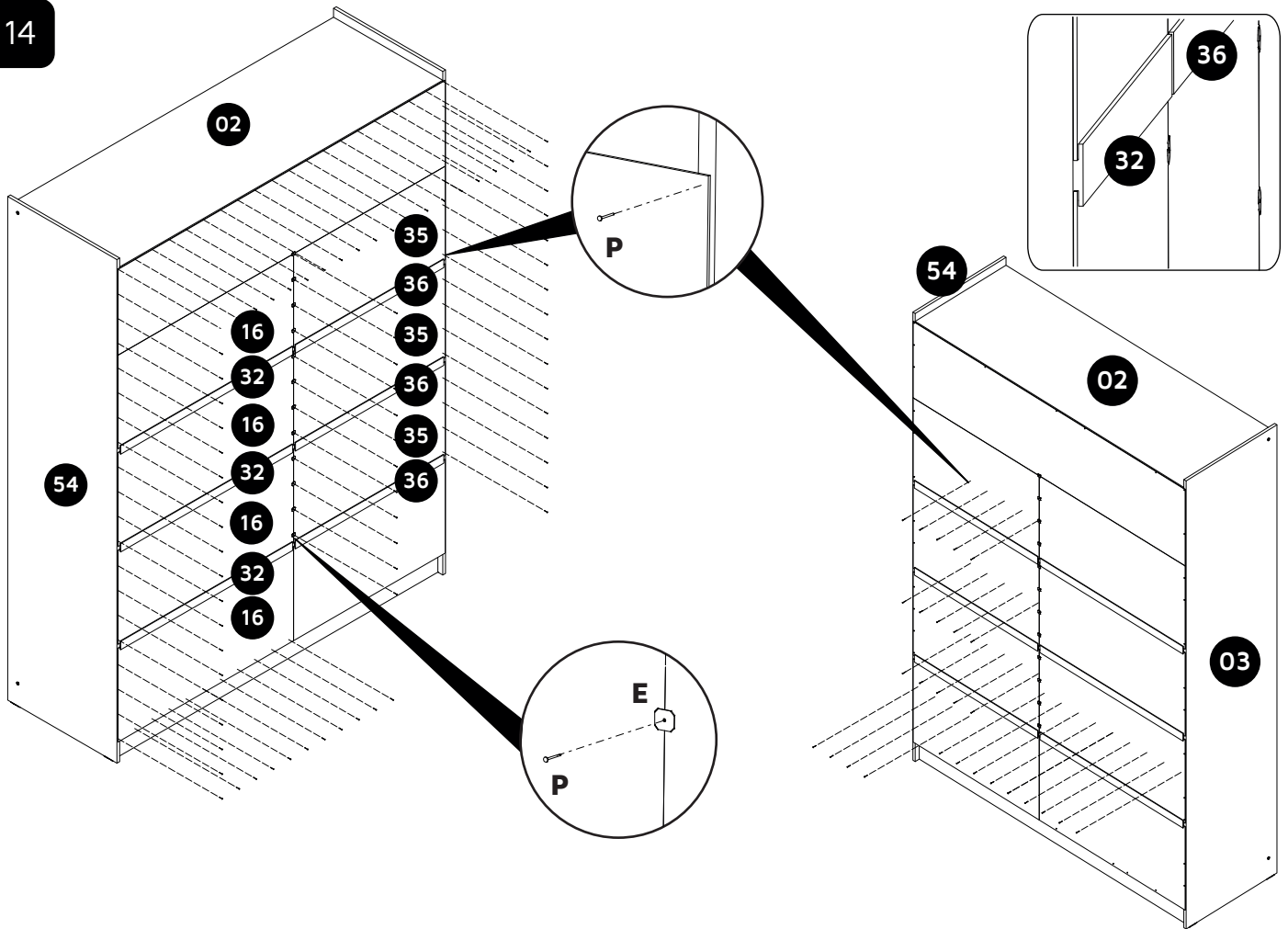

14

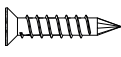

15

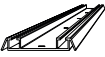
K COD. 3557	L COD. 16949	T1/T2/T3 COD. 17057	Z COD. 17017	AA COD. 17018
				

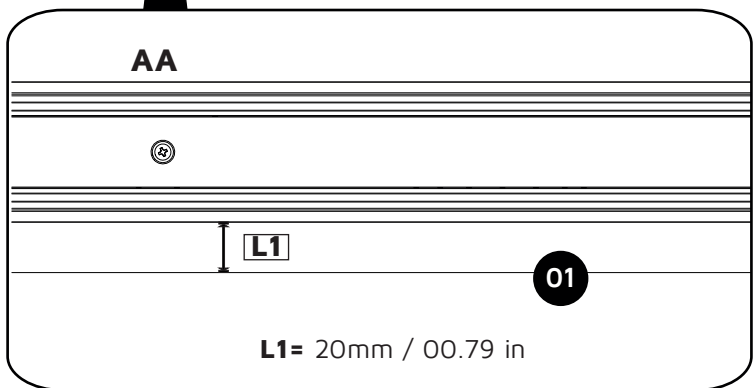
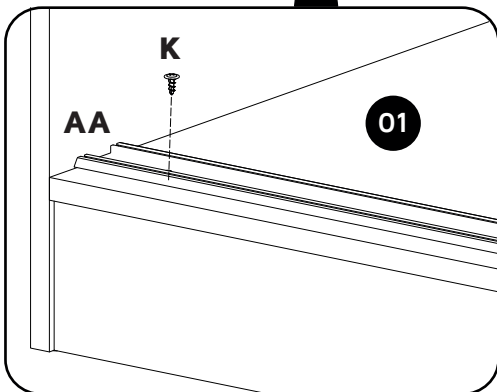
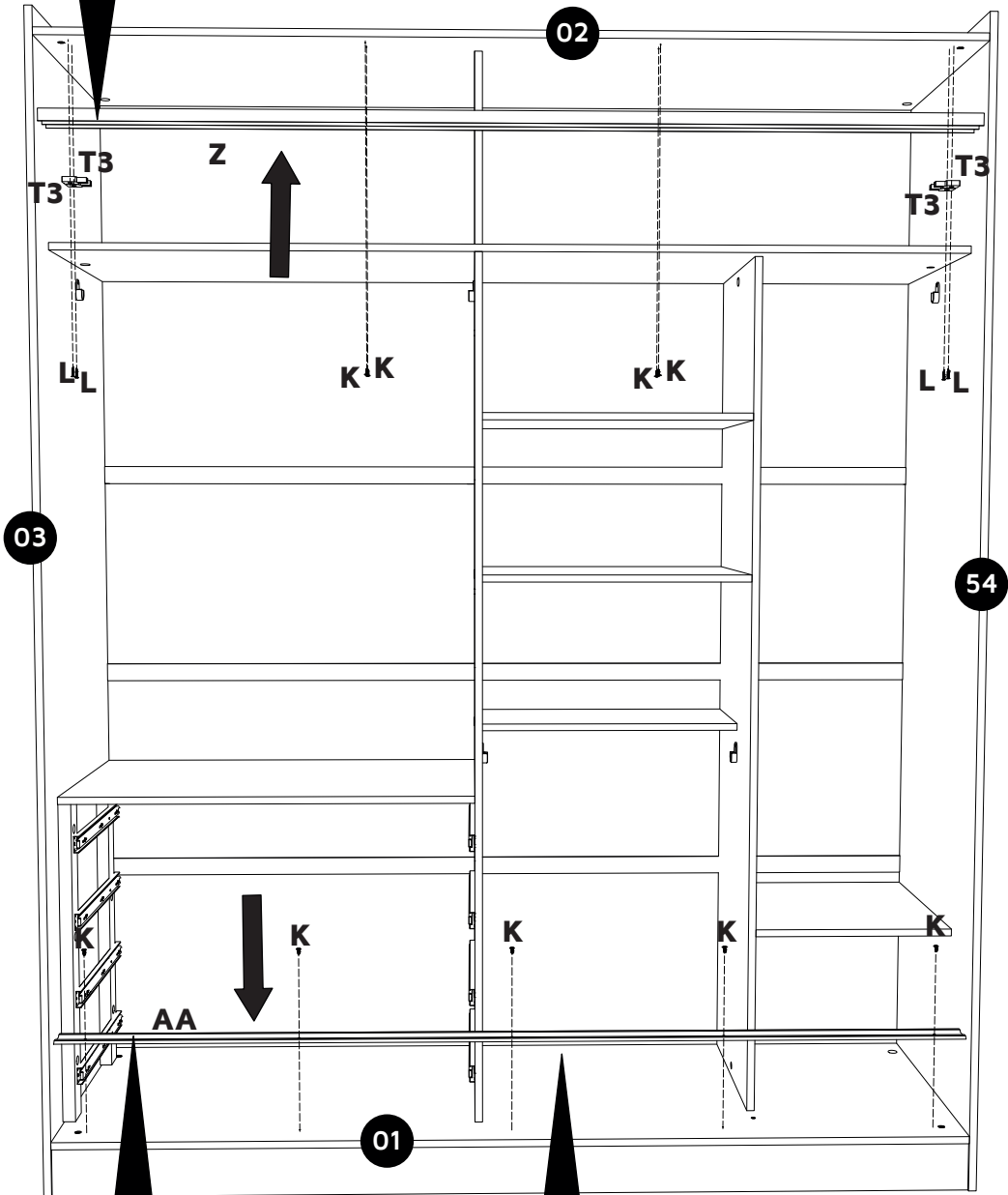
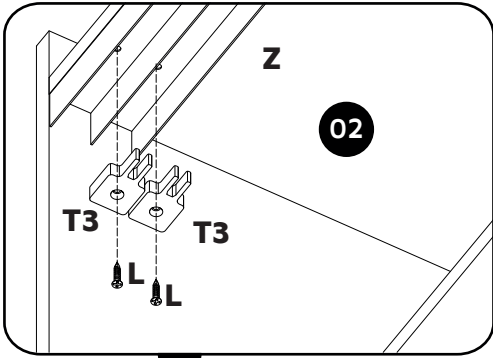

16

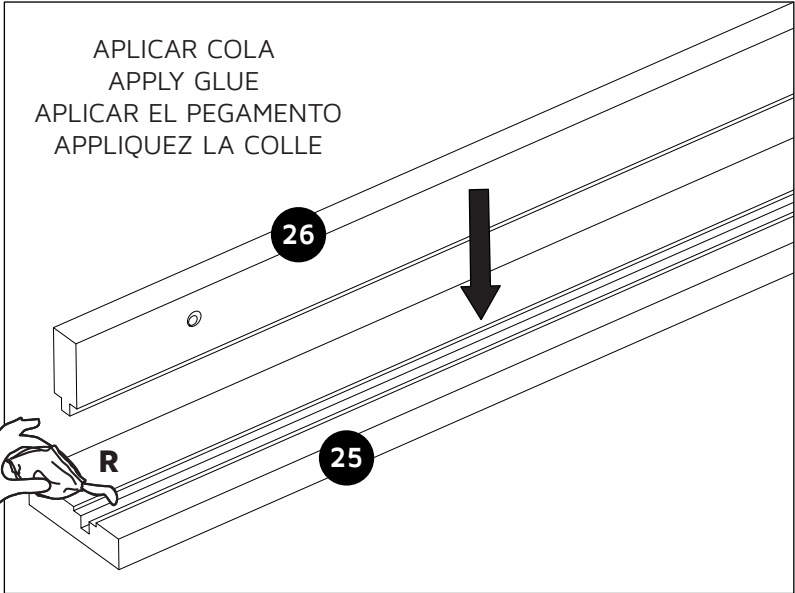

A 	N COD. 0716 	R COD. 9509
--------------	---------------------------	---------------------------

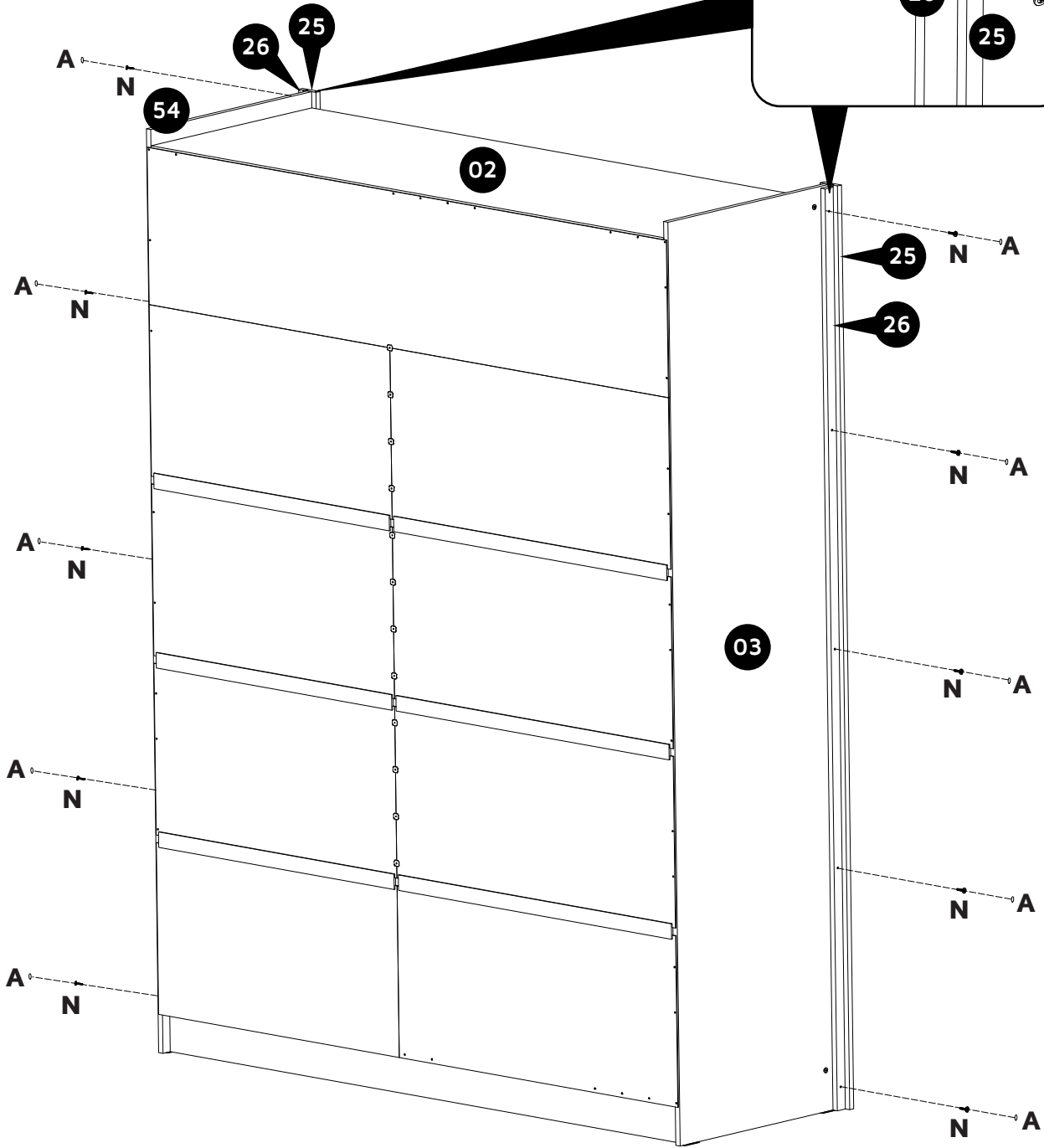
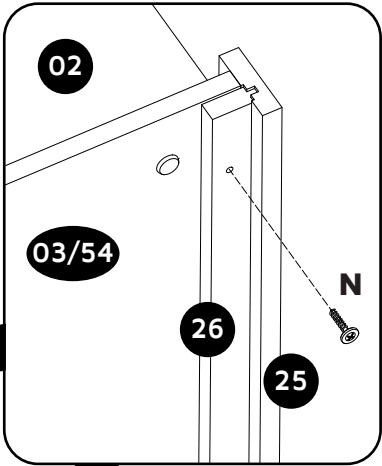

17

D COD. 1668	F COD. 4067	J COD. 1533	K COD. 3557	M COD. 0715	U COD. 0602

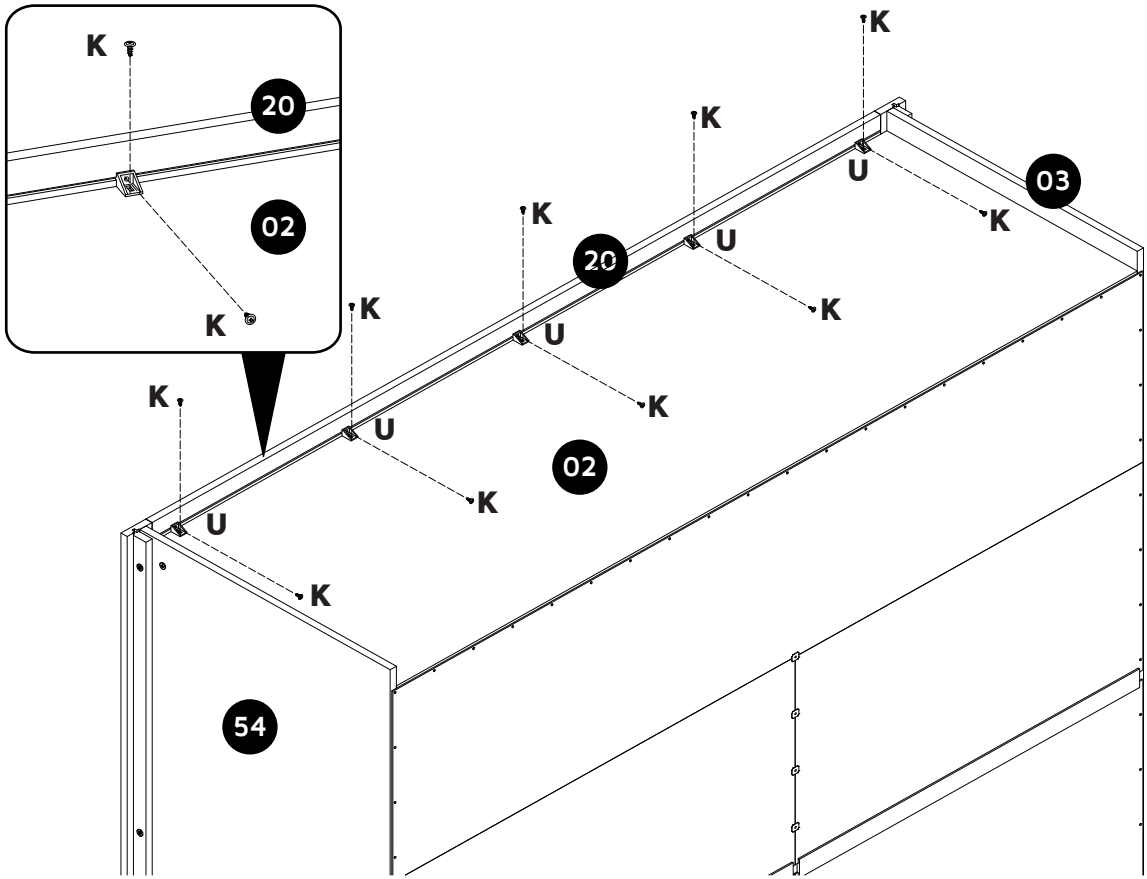



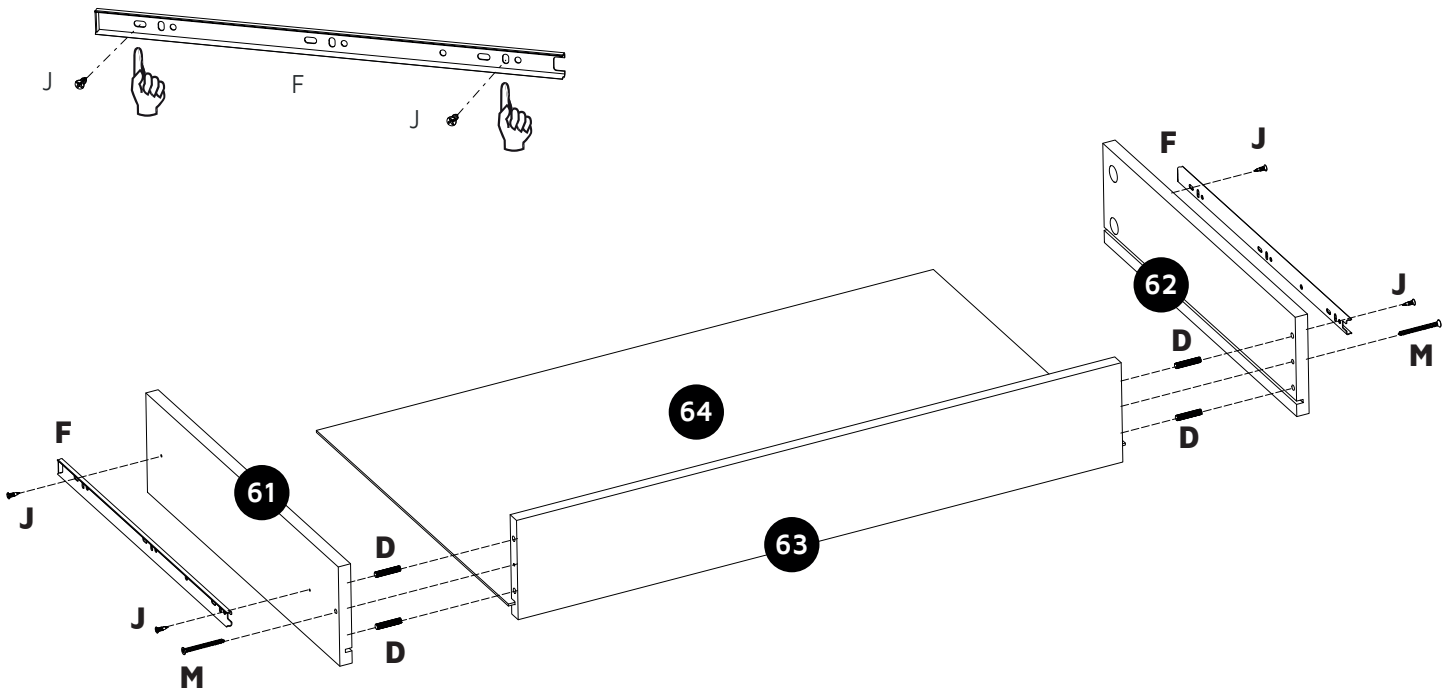

18

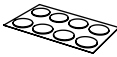

(4x)

19

A 	C COD. 10063 	D COD. 1668 	H COD. 0599 
--	---	--	--

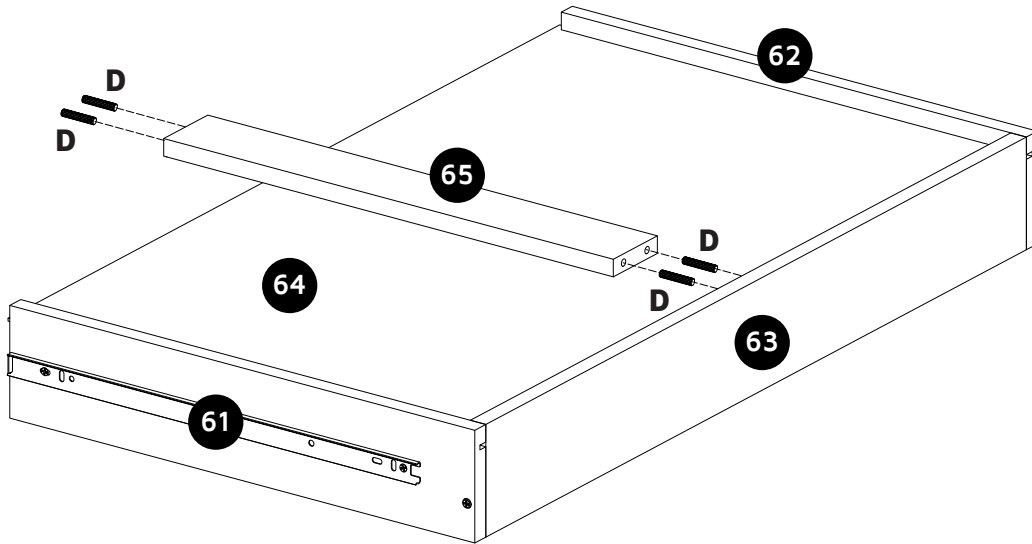





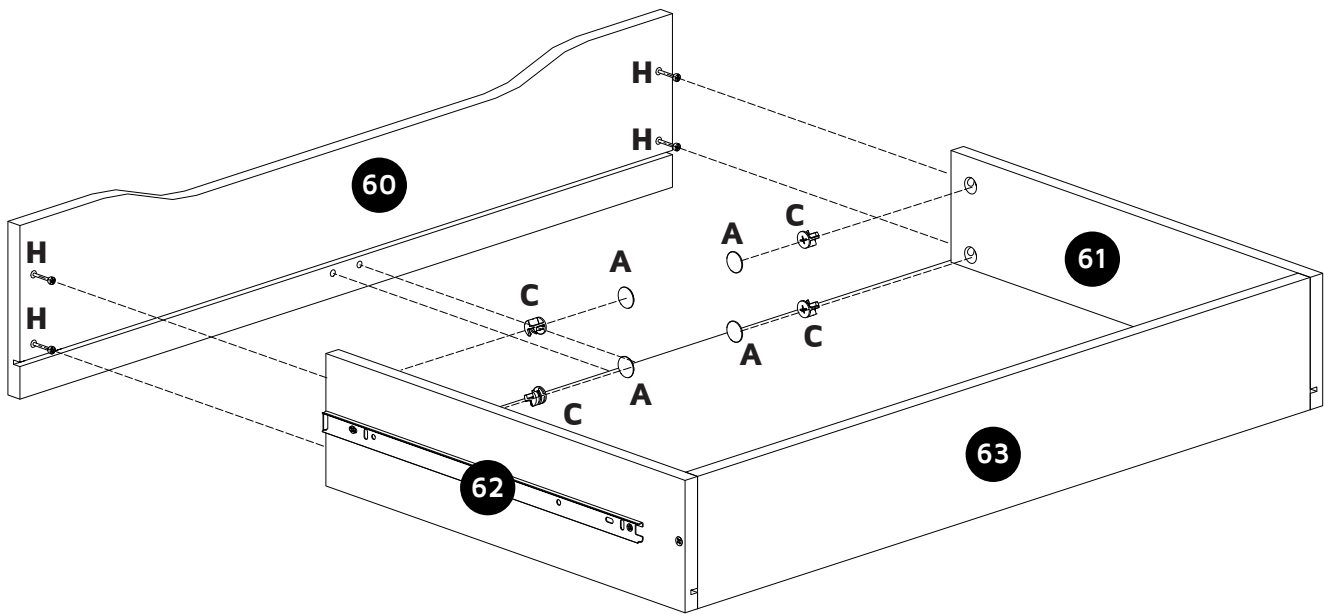

(4x)

20

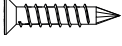

(4x)

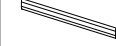
21

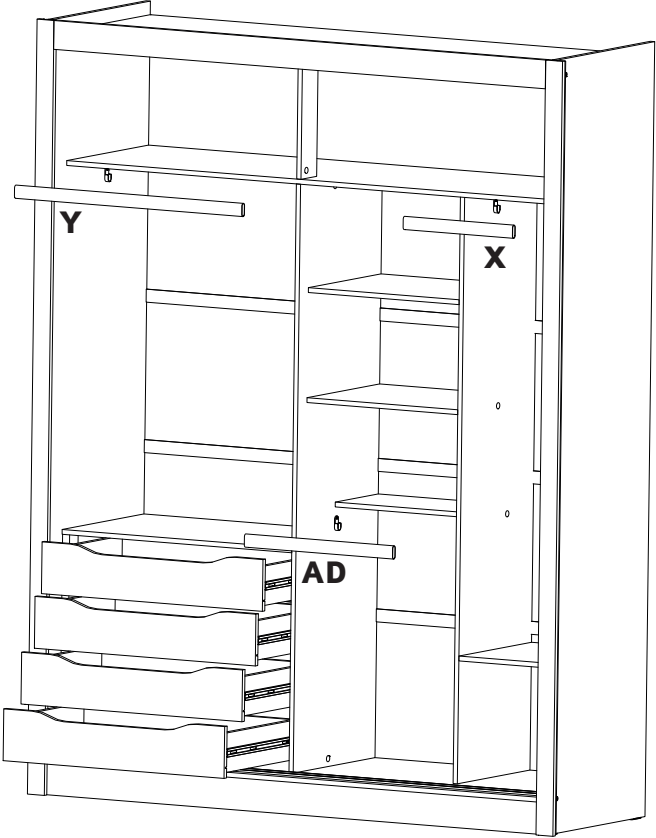
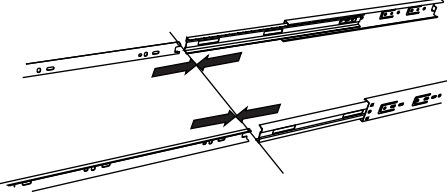

L COD. 16949	Q	X COD. 17032	Y COD. 17022	AD COD. 17023	AE COD. 1861
					

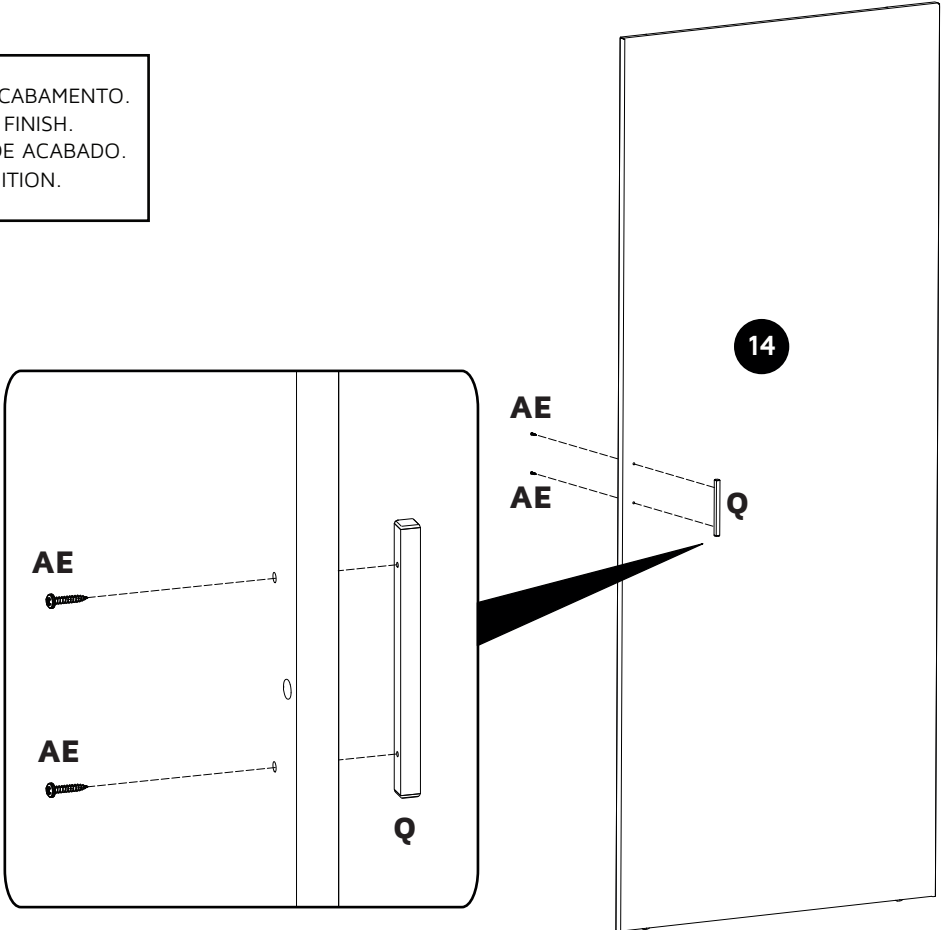

22

 A PORTA TEM 2 TIPOS DE ACABAMENTO.
THE DOOR HAS 2 TYPES OF FINISH.
LA PUERTA TIENE 2 TIPOS DE ACABADO.
LA PORTE A 2 TIYPES DE FINITION.

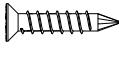
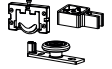

K COD. 3557	L COD. 16949	T1/T2/T3 COD. 17057	AB CP21718
			

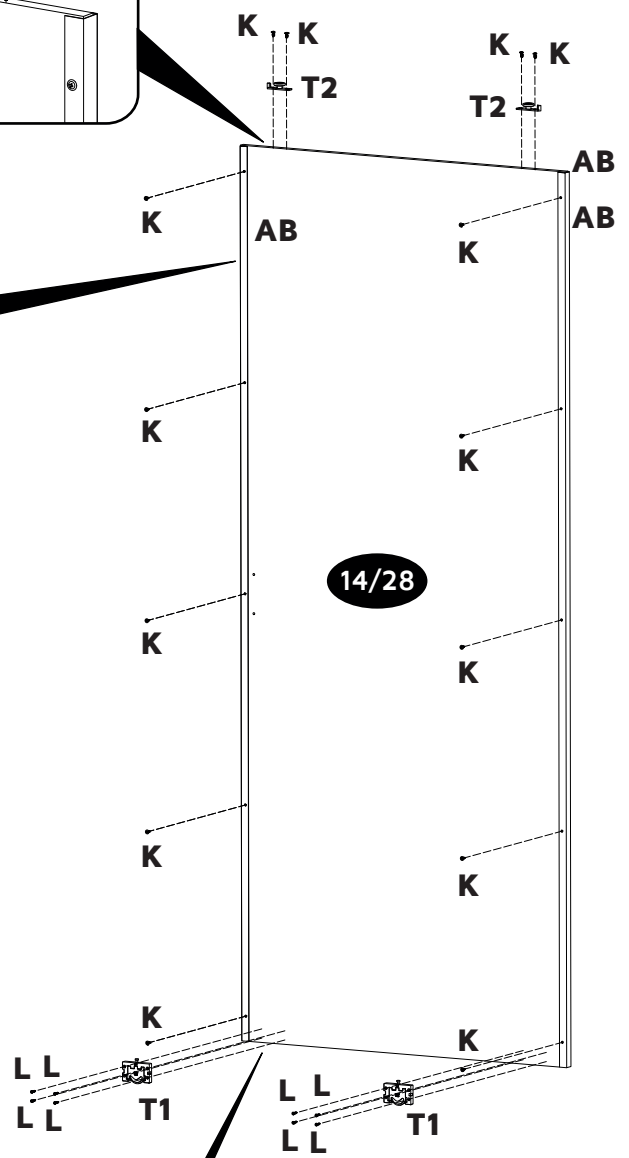
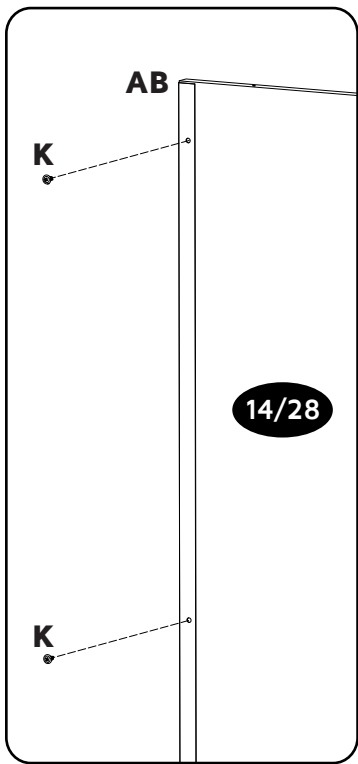
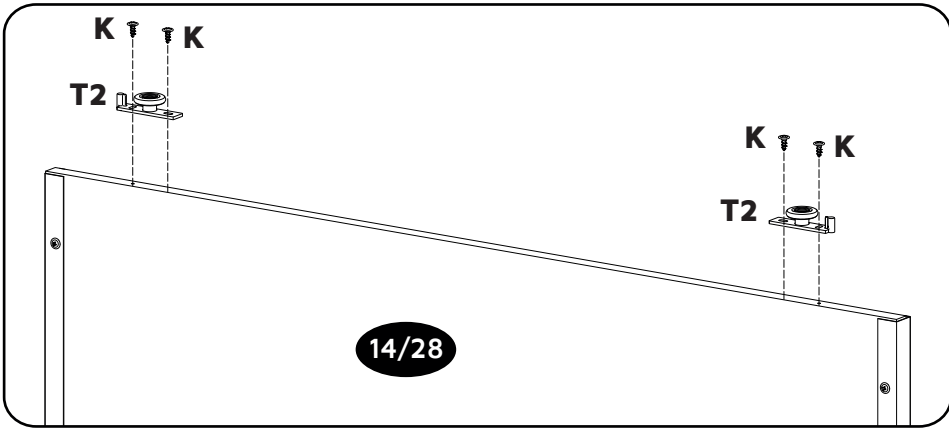

! A PORTA TEM 2 TIPOS DE ACABAMENTO.
THE DOOR HAS 2 TYPES OF FINISH.
LA PUERTA TIENE 2 TIPOS DE ACABADO.
LA PORTE A 2 TYPES DE FINITION.

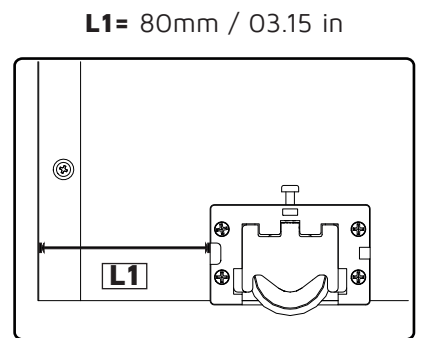
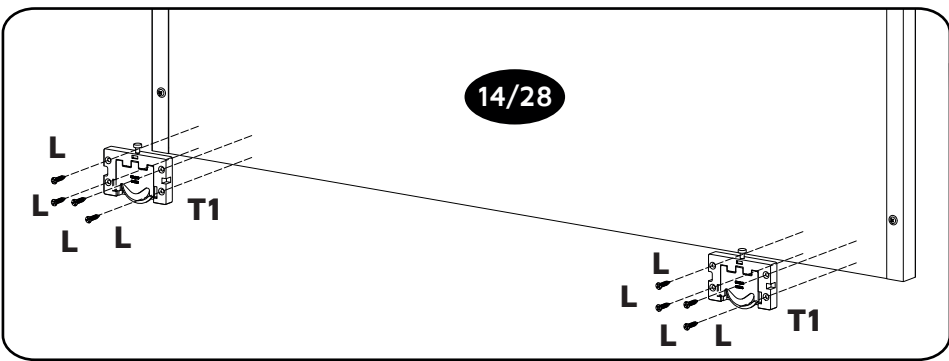

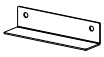
K COD. 3557 	AC CP21719 	AF ESPELHO MIRROR ESPEJO MIROIR
--	---	--



O PRODUTO ESPELHO (**PA5100300**) É OPCIONAL. *VENDIDO SEPARADAMENTE
THIS IS ADD-ON ITEM MIRROR (**PA5100300**). *SOLD SEPARATELY.
EL ACCESORIO ESPEJO (**PA5100300**) ES OPCIONAL. *SE VENDE EN SEPARADO.
LE PRODUIT MIROIR (**PA5100300**) EST OPTIONNEL. *VENDU SÉPAREMENT.



EM CASO DE COMPRA DO ESPELHO (**PA5100300**), SEGUIR OS PRÓXIMOS PASSOS.
IF YOU PURCHASE THE MIRROR (**PA5100300**), FOLLOW THE NEXT STEPS.
SI COMPRAS EL ESPEJO (**PA5100300**), SIGUE LOS SIGUIENTES PASOS.
SI VOUS ACHETEZ LE MIROIR (**PA5100300**), SUIVEZ LES ÉTAPES SUIVANTES.

L1= 2mm / 00.079 in

L2= 3mm / 00.118 in

L3= 1mm / 00.039 in

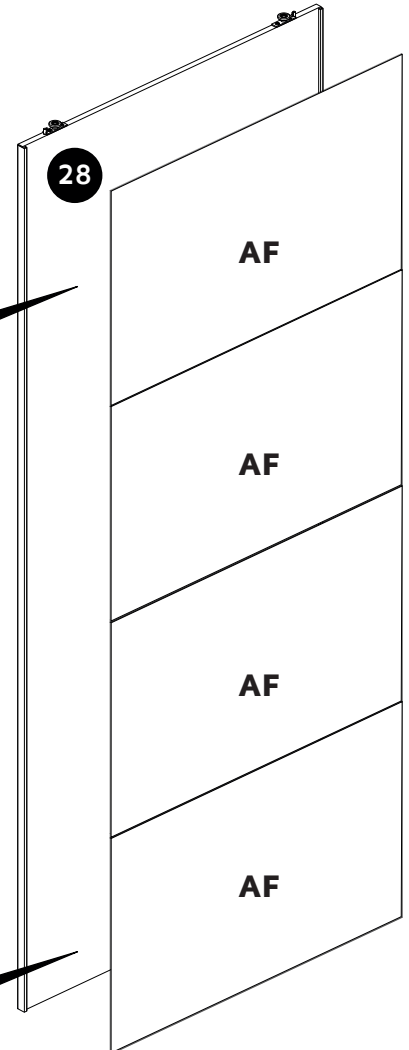
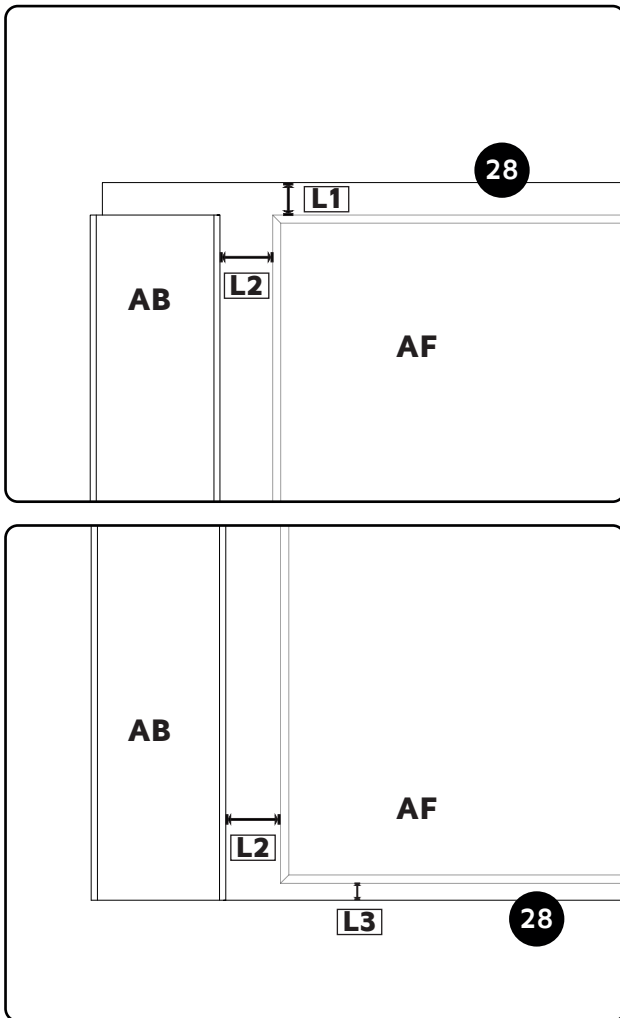

FIXAR O ITEM "AC" (**CP21719**) SOMENTE EM CASO DE COMPRA DO ESPELHO (**PA51000300**)
FIX THE ITEM "AC" (**CP21719**) ONLY IF YOU PURCHASE THE MIRROR (**PA51000300**)
ARREGLE EL ARTÍCULO "AC" (**CP21719**) SÓLO SI COMPRAS EL ESPEJO (**PA51000300**)
RÉPARER L'ARTICLE "AC" (**CP21719**) SEULEMENT SI VOUS ACHETEZ LE MIROIR (**PA51000300**)

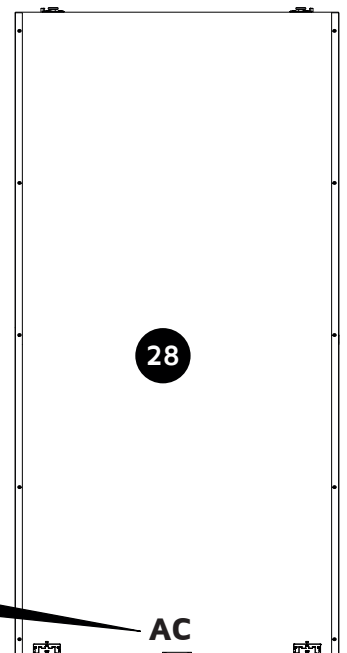
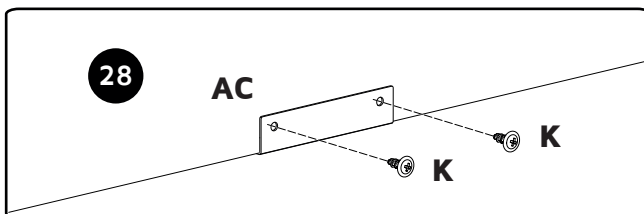

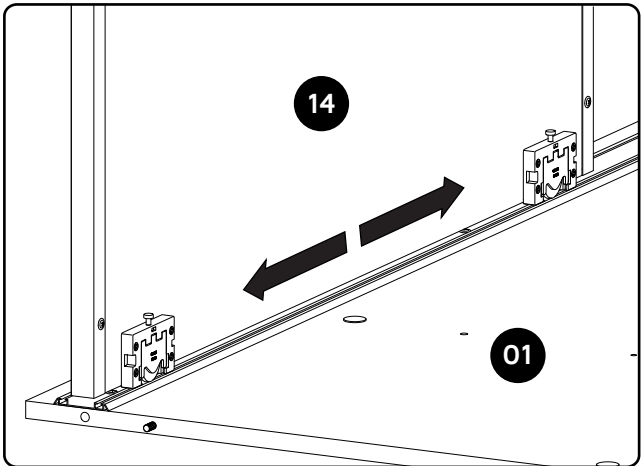
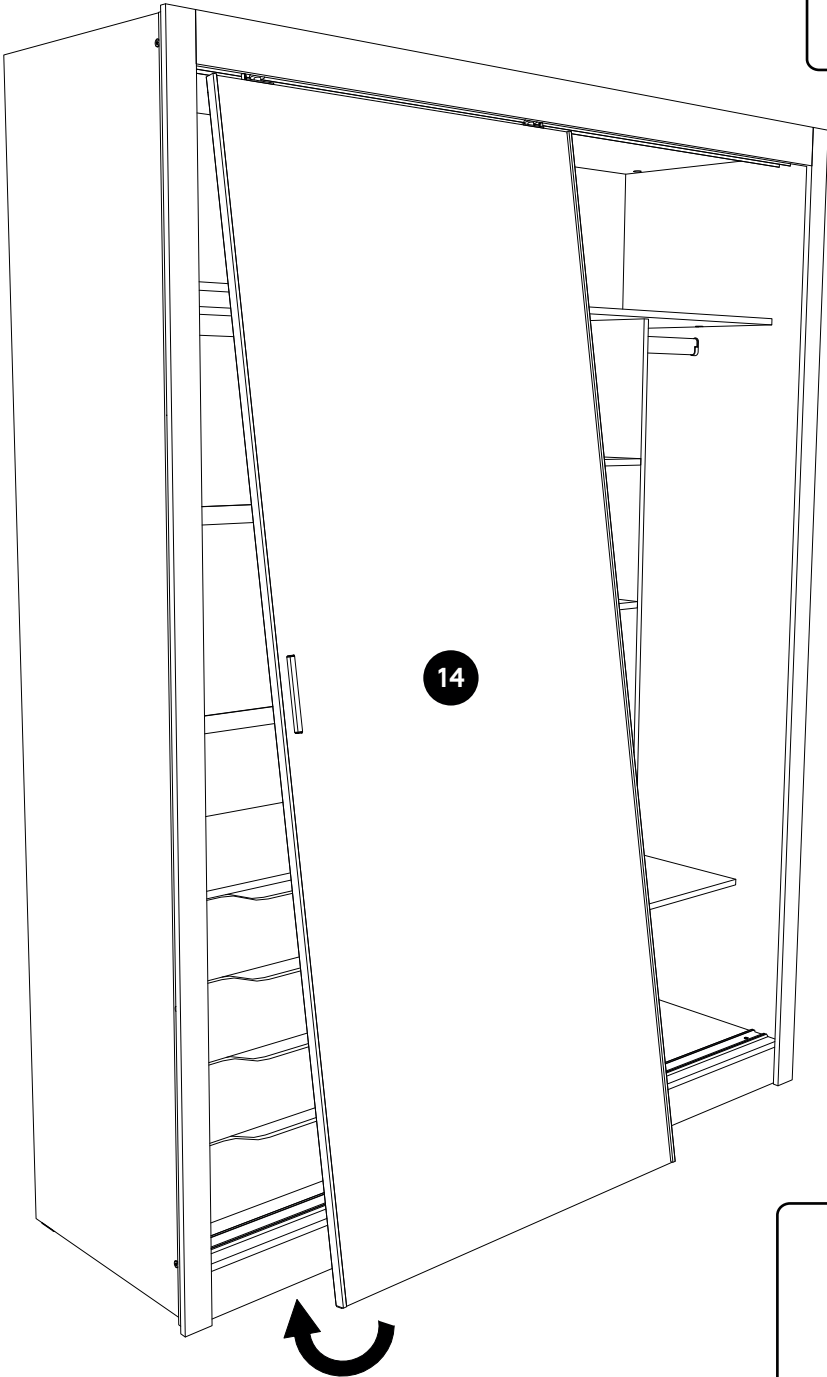
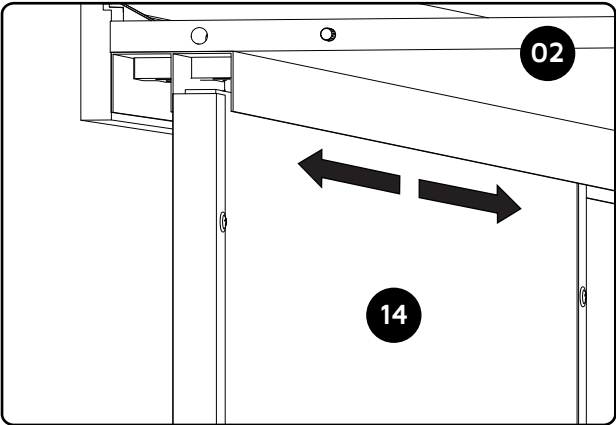

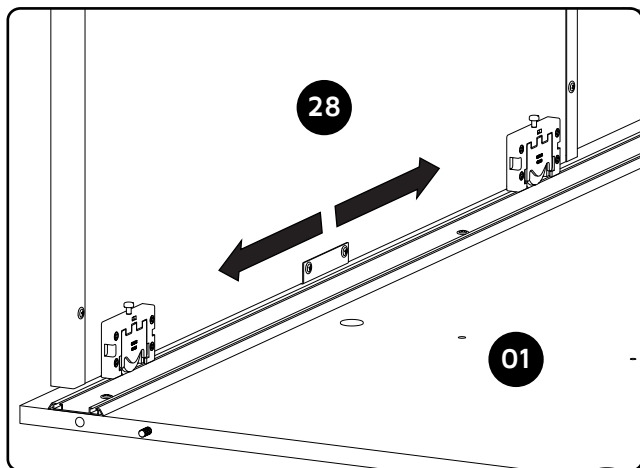
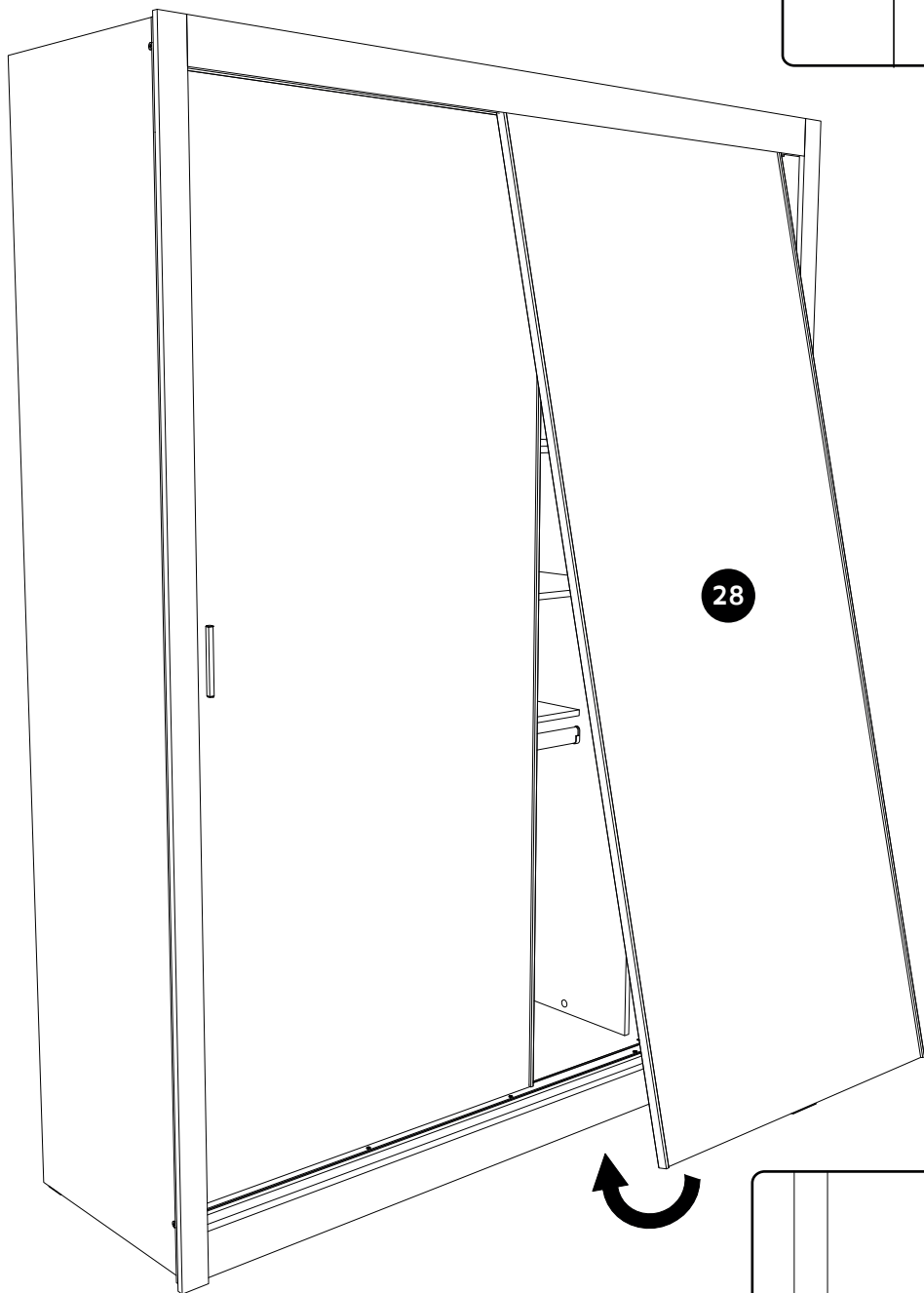
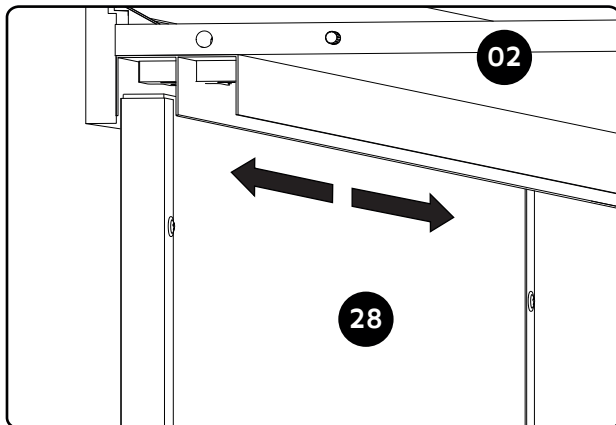

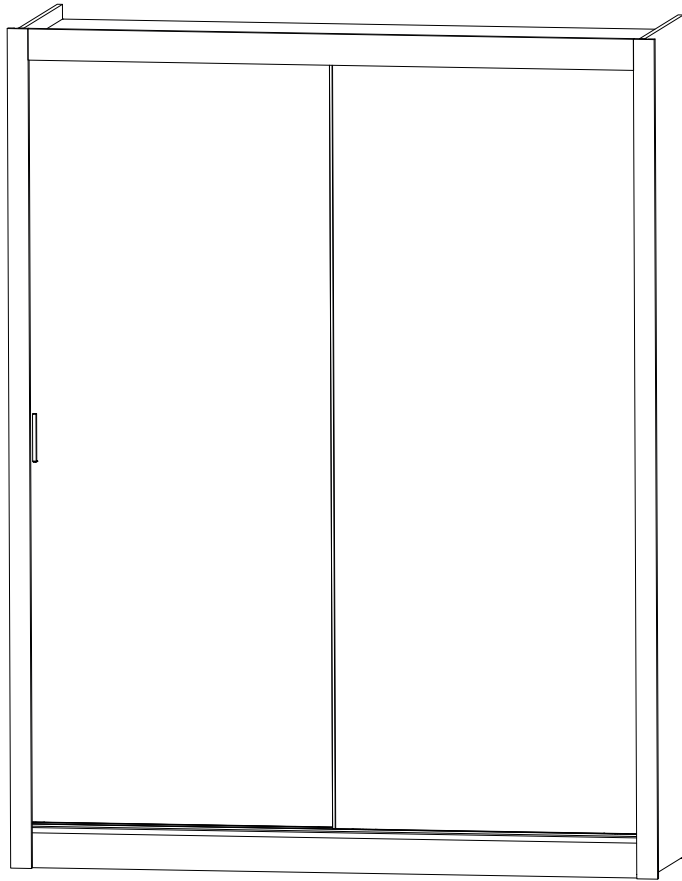

OU
OR ELSE
SI NO
OU BIEN

