



### Fone (32) 3539-7600

Rod. Ubá - Rodeiro, Km 03 - Galpão 1  
C. P 050 - CEP 36500-000 - Ubá - MG  
E-mail: mavaular@mavaular.com.br - Site: www.mavaular.com.br

## Instruções de Montagem Rack Arezzo 1800

*Rack Arezzo 1800 Assembly Instructions*  
*Instrucciones de montaje del Rack Arezzo 1800*  
CÓDIGO: 10425

✓ Atualizado em:  
30/08/2022

### CUIDE BEM DO SEU MÓVEL

Dicas de limpeza e conservação:

- Para limpar corretamente seu produto, use sempre um pano liso e **levemente** umedecido com água;
- Não se esqueça de enxugar o seu móvel! Ele não deve permanecer úmido, pois a água pode prejudicar o acabamento ou causar mofo na madeira;
- Não se recomenda o uso de produtos à base de amoníaco.
- Não utilize esponja de aço ou qualquer material que possa arranhar a superfície do produto durante a limpeza.
- Não utilize plásticos ou papéis coloridos para forrar seu móvel.
- Evite arrastar objetos em cima do móvel. Eles podem riscar e prejudicar o acabamento de seu móvel de
- O material dos seus móveis tem um tratamento contra fungos e cupins, mesmo assim, em ambientes infestados recomenda-se a dedetização antes de instalar a seu móvel;
- Tente evitar a exposição direta ao sol. Sugere-se utilização de cortinas para proteger seu móvel;

### TAKING GOOD CARE OF YOUR FURNITURE

Cleaning and caring instructions:

- Wipe the wood furniture down with a moist cloth to properly clean the furniture.
- Do not forget to dry your furniture out. Humidity can damage the finish or create mould.
- Chemical products are not recommended;
- Never clean the furniture with scouring powders, steel scrubber pads or any other product which can scratch its surface.
- Furniture surfaces should not be covered with colored plastic or paper sheets.
- Avoid dragging objects on top of the furniture. They might scratch the finishing.
- Wood furniture are made of mould and termites resistant materials, however, it is recommended to use termiticides in infested places before installing the furniture.
- Avoid furniture exposure to direct Sun light. Drapers suggested.

### CUIDE BIEN DE SU MUEBLE

Indicaciones de limpieza y conservación

- Para limpiar correctamente su muebles de madera, siempre use un paño húmedo.
- No se olvide de secar su muebles! No debe permanecer húmedo, pues el agua puede perjudicar el acabado o causar moho en la madera.
- No es recomendable utilizar productos con amoníaco.
- No utilizar esponjas de acero o cualquier material que dañe la superficie de los muebles.
- No utilizar plásticos o papeles coloridos para forrar los muebles.
- Evite arrastrar objetos encima de los muebles. Ellos pueden riscar o dañar el acabado de su mueble de cocina.
- El material de los muebles tiene un tratamiento contra los hongos y las polillas, aun así, en ambientes infectados, se recomienda desinfectar antes de instalar su mueble.
- Evite la exposición directa al sol. Se sugiere la utilización de cortinas para proteger sus muebles.

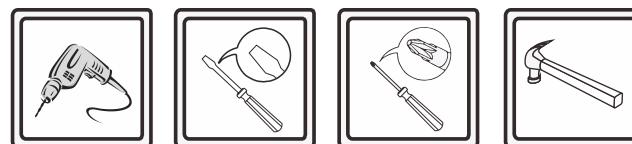
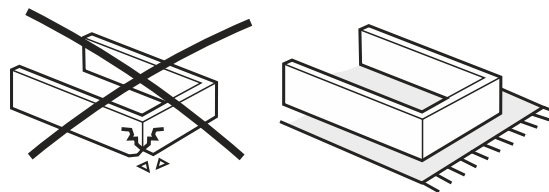
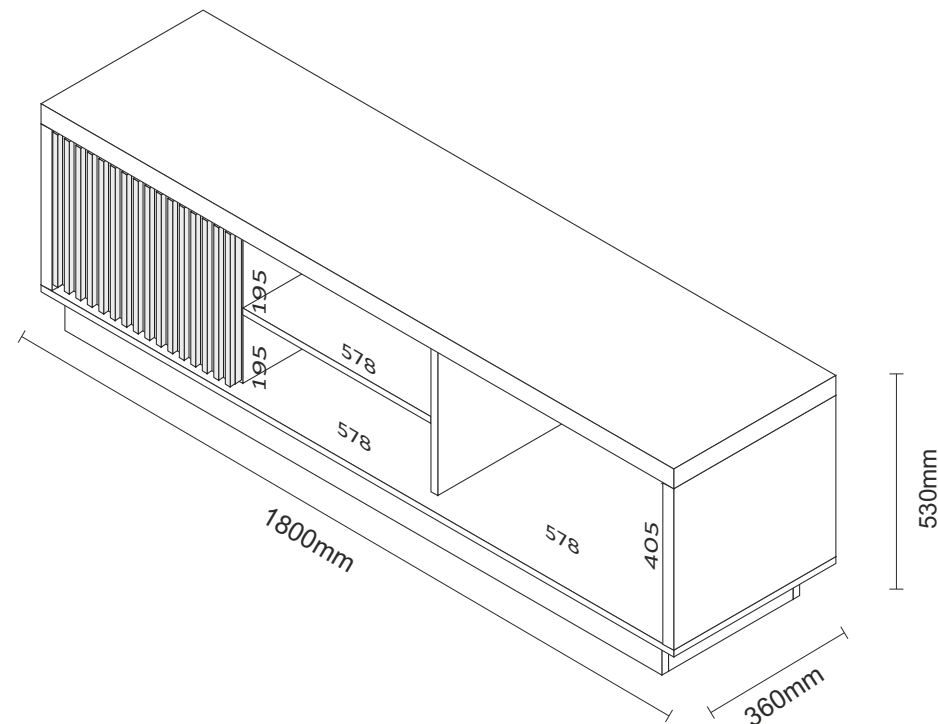

As ferramentas necessárias para montagem do produto não são fornecidas.  
The necessary tools for assembly aren't supplied.  
Las herramientas necesarias para armar los productos no son fornecidas.

N°	CÓDIGO CODE CÓDIGO	DESCRIÇÃO DESCRIPTION DESCRIPCIÓN			DIMENSÃO (mm) DIMENSION (mm) DIMENSIÓN (mm)			QUANTIDADE QUANTITY CANTIDAD
					COMP. LEN. LON.	LARG. WID. ANC.	EPS DEP ESP	
1	8864	Tampo	Cover	Cubrir	1800	355	40	1
2	10002	Lateral Direita / Esquerda	Right/Left Side	Lado derecho/izquierdo	405	350	15	2
3	10004	Divisão	Division	División	405	300	15	2
4	10005	Prateleira	Shelf	Estante	578	298	15	1
5	10006	Base	Basis	Base	1800	355	15	1
6	8859	Rodapé Lateral	Side Footer	Pie de página lateral	310	70	25	2
7	8860	Rodapé Interno	Internal footer	Pie de página interno	293	70	25	2
8	10009	Rodapé Traseiro	back footer	pie de página posterior	1700	70	15	1
9	10008	Rodapé Frontal	Front footer	Pie de página frontal	1755	70	15	1
10	10134	Costa Central	Central Coast	Costa central	590	218	2,5	2
11	10427	Costa Lateral Superior	Upper Side Coast	Costa lateral superior	590	80	2,5	2
12	10133	Costa Lateral Inferior	Lower Side Coast	Costa lateral inferior	590	350	2,5	2
13	8865	Porta	Door	Puerta	600	397	12	1

A - PARAFUSO 4X40MM  
4X40MM SCREW  
TORNILLO 4X40MM

x12

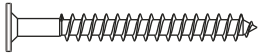

G - PREGO 10X10  
NAIL 10X10  
CLAVOS 10X10

x50



M - PARAFUSO 3,5X14MM  
3,5X14MM SCREW  
TORNILLO 3,5X14MM

x08



B - CAVILHA MADEIRA 6X30MM  
6X30MM WOODEN DOWEL  
TARUGO DE MADEIRA 6X30MM

x08



H - TAPA FURO ADESIVO  
ADHESIVE HOLE COVER  
TAPA AGUJERO ADHESIVO

x04



N - PARAFUSO 3,5X12MM  
3,5X12MM SCREW  
TORNILLO 3,5X12MM

x08



C - CONECTOR DE MONTAGEM  
MOUNTING CONNECTOR  
CONECTOR DE MONTAJE

x20



I - ROLDANA  
PULLEY  
POLEA

x02

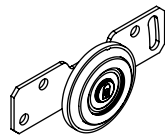

O - PERFIL H  
PROFILE H  
PERFIL H

x02

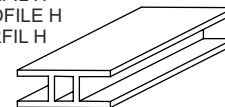

D - PARAFUSO 3,5X14MM  
3,5X14MM SCREW  
TORNILLO 3,5X14MM

x80



J - GUIA PORTA CORRER  
SLIDING DOOR GUIDE  
GUÍA PUERTA CORREDERA

x02

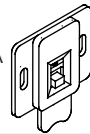

P - TRILHO  
RAIL  
CARRIL

x02

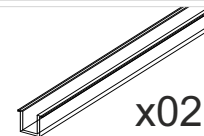

E - CAVILHA MADEIRA 8X30MM  
8X30MM WOODEN DOWEL  
TARUGO DE MADEIRA 8X30MM

x08



K - GARRA FUNDO  
DEEP CLAW  
GARRA PROFUNDA

x10

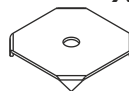

F - SAPATA REDONDA  
ROUND SHOE  
ZAPATO REDONDO

x08



L - BATENTE DE SILICONE  
SILICON STOP  
TOPE DE SILICIO

x04

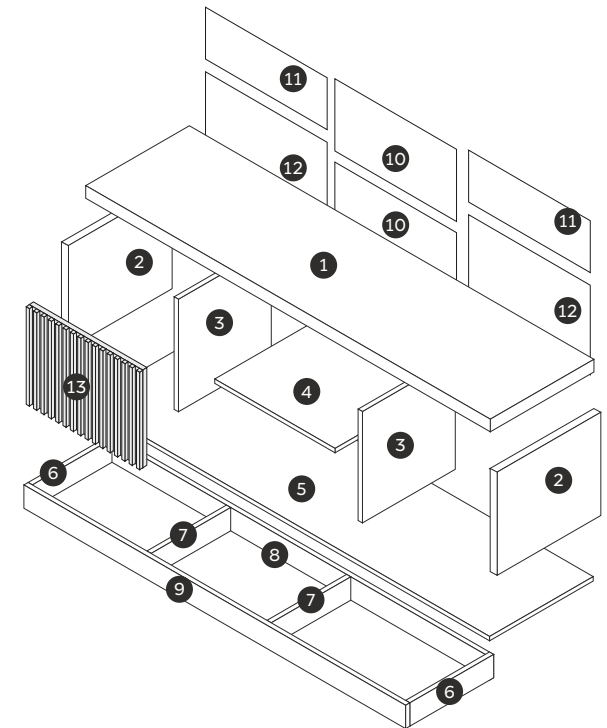

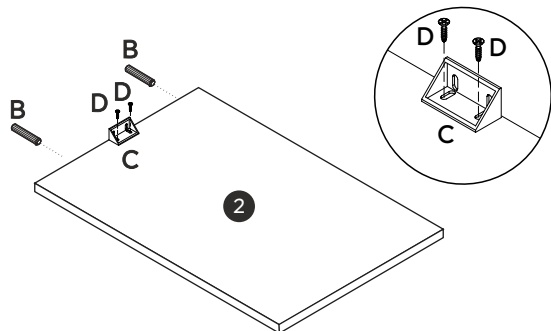
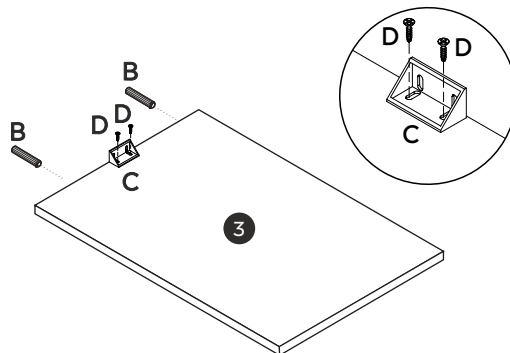
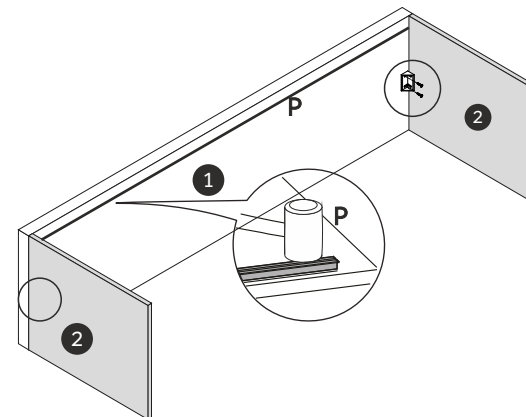
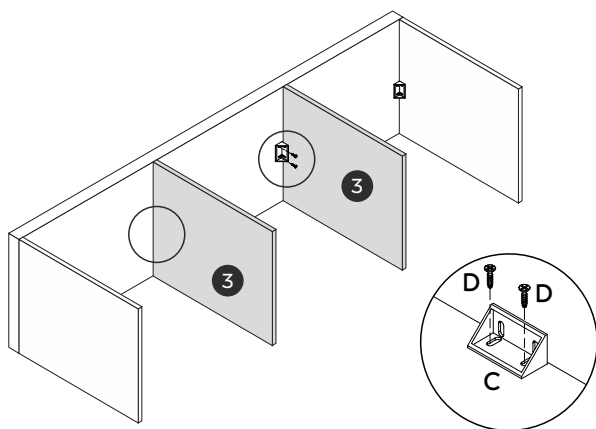
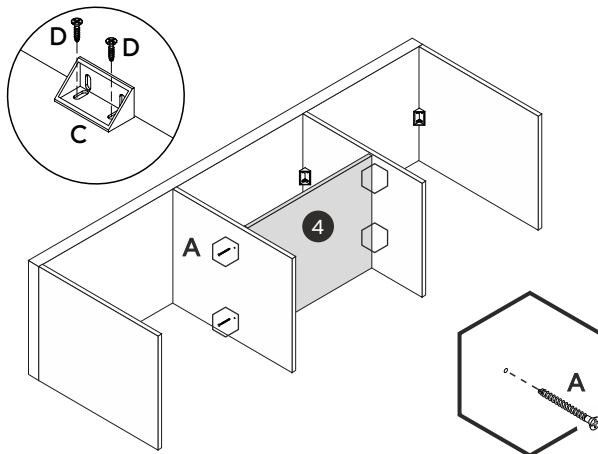
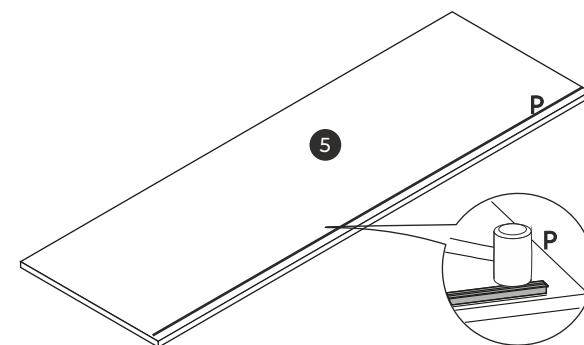
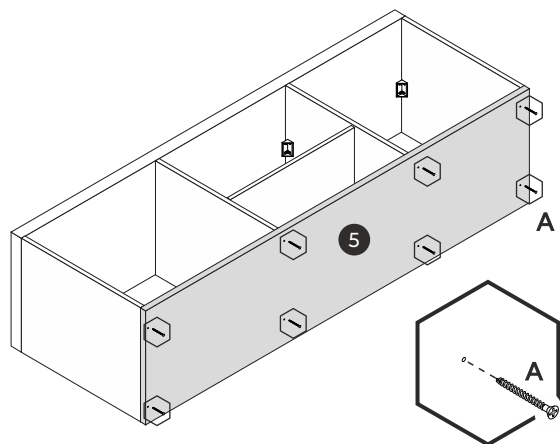
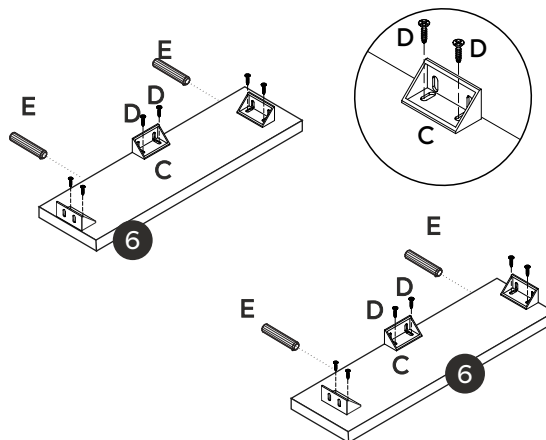
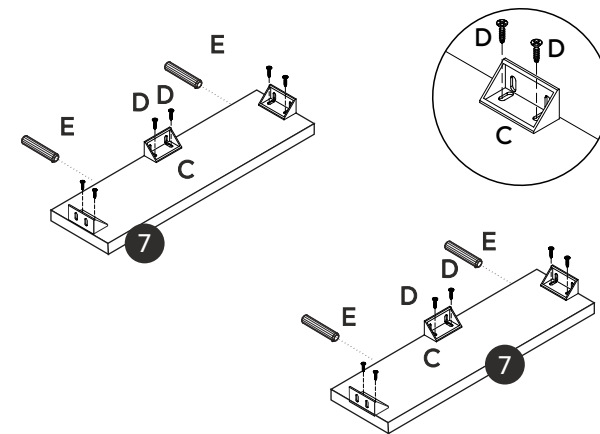
**1****2****3****4****5****6****7****8****9**

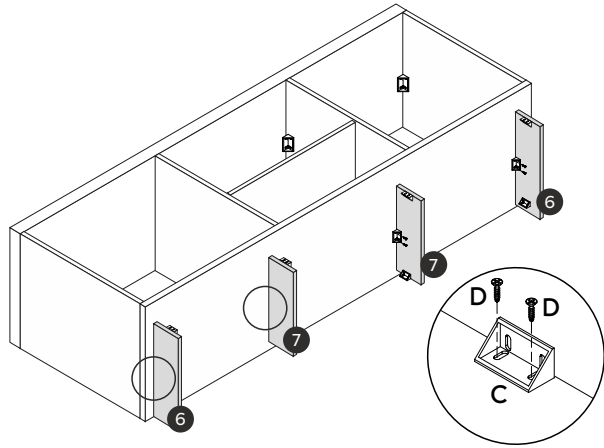
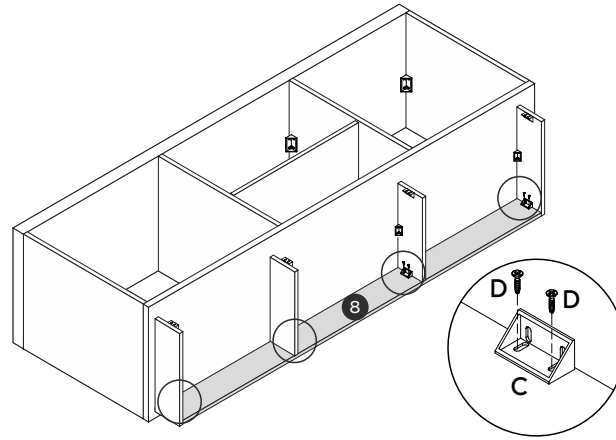
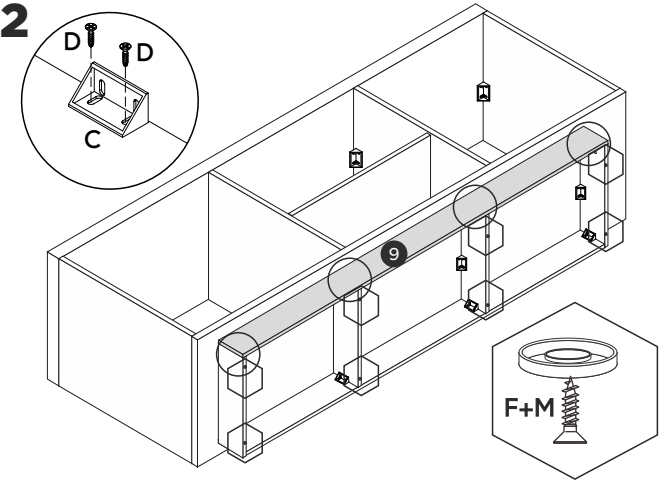
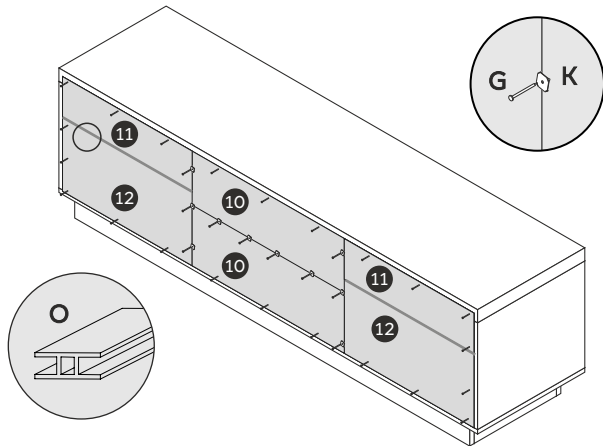
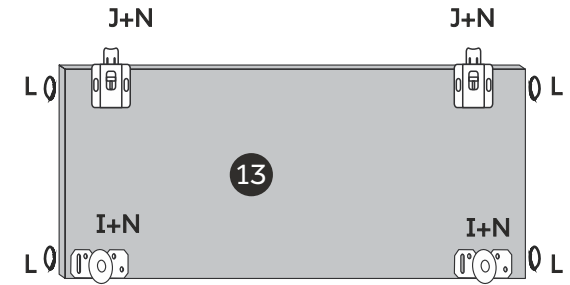
**10****11****12****13****14**

**Importante: para colar o batente da porta, remova a proteção e cole na porta**  
**Important: to glue the door frame, remove the protection and glue it to the door**  
**Importante: para pegar el marco de la puerta, quitar la protección y pegarla a la puerta**

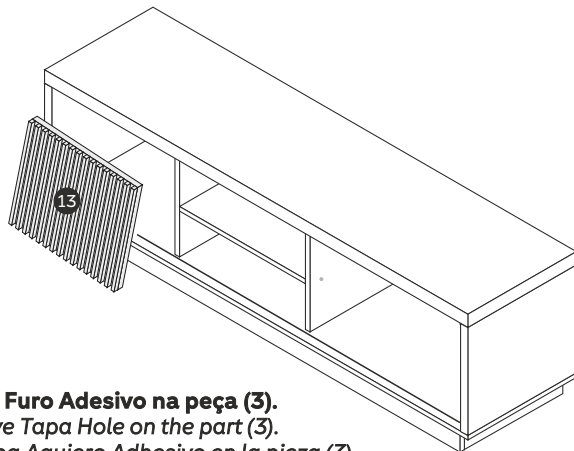
**15**

**Importante: Usa Tapa Furo Adesivo na peça (3).**  
**Important: Use Adhesive Tapa Hole on the part (3).**  
**Importante: Utilizar Tapa Agujero Adhesivo en la pieza (3).**

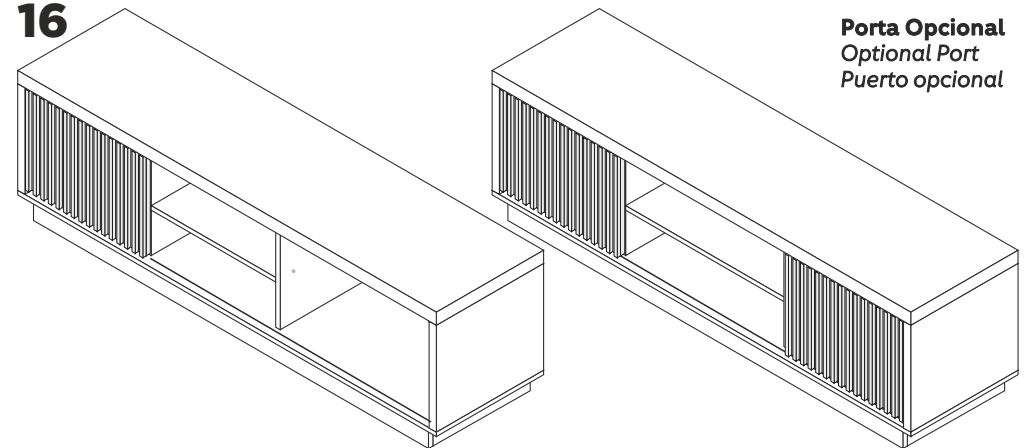
**16**

**Porta Opcional**  
**Optional Port**  
**Puerto opcional**