

MANUAL DE MONTAGEM

ASSEMBLY INSTRUCTIONS

INSTRUCCIONES DE MONTAJE

NOTICE DE MONTAGE

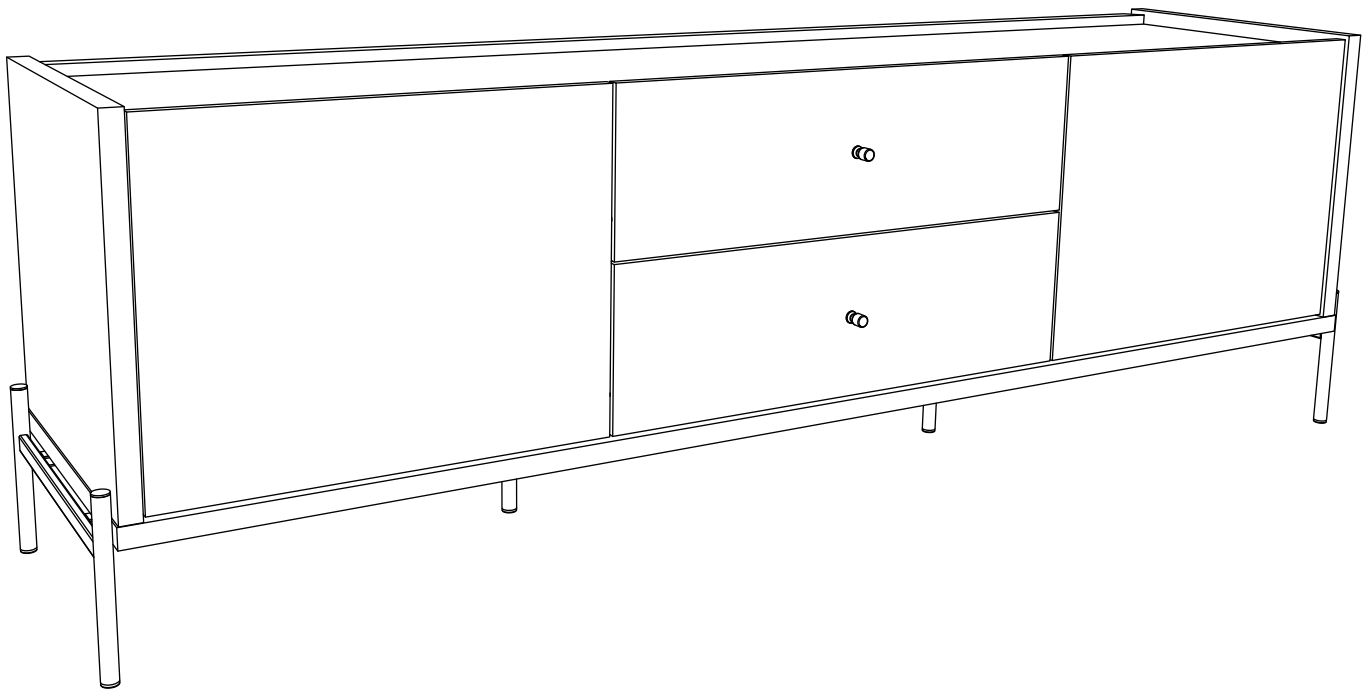

1852mm

COD: 225600

COD: 226800

2202mm

COD: 225700

COD: 226900

OBSERVAÇÕES IMPORTANTES IMPORTANT REMARKS OBSERVACIONES IMPORTANTES REMARQUES IMPORTANTES



Nunca escale ou se apoie sobre o móvel. Você pode sofrer graves acidentes.

Never climb or lean on the furniture. You may suffer serious accidents.

Nunca escale o apoie sobre el mobiliario. Usted puede sufrir graves accidentes.

Ne montez jamais sur le meuble. Vous pourriez subir un grave accident.

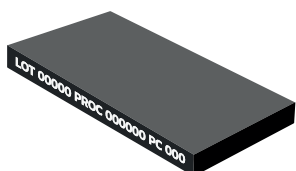

Observe os números impressos nas bordas para identificar as peças.

Identify the parts by observing the number printed on their edges.

Identifique las piezas observando el numero impreso en sus bordes.

Notez les numéros imprimés sur les bords pour identifier les pièces.



Movimente o móvel com cuidado, sem arrastar. Peça ajuda a outra pessoa para fazê-lo.

Move the piece carefully, don't drag it. Ask for someone else's help to do so.

Mover la unidad con cuidado, sin arrastar. Pedir ayuda da otra persona para moverlo.

Déplacez les meubles avec précaution sans le faire glisser. Demandez a quelqu'un de vous aider à le faire.

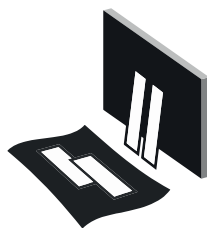

Utilize a embalagem para forrar a área de montagem e separar todas as peças.

Use the packaging to cover the assembly area and separate all parts.

Utilice el embalaje para cubrir la area de montaje y separe las piezas.

Couvrez la zone d'assemblage avec l'emballage pour séparer le pièces.



Limpe com um pano limpo e umedecido em água e sabão neutro. Não utilizar produtos químicos e abrasivos.

Wipe clean using a damp cloth and a mild cleaner. Don't use abrasive and chemical products.

Limpie con un paño limpio humedecido con agua y jabón neutro. No utilice productos químicos y abrasivos.

Nettoyez avec un chiffon propre imbibé avec d'eau et de savon doux. N'utilisez pas de produits chimiques et abrasifs.



Não colocar objetos em alta temperatura diretamente sobre superfícies de vidro.

Do not place high-temperature objects directly on glass surfaces.

No coloque objetos de alta temperatura directamente sobre superfícies de vidro.

Ne placez pas d'objets à haute température directement sur les surfaces en verre.

ACESSÓRIOS HARDWARE HERRAJES ACCESSOIRES

Identifique e separe os acessórios utilizados. Em cada embalagem, uma etiqueta identifica as peças e onde utilizá-las.

Identify and separate the hardware used in the assembly. There's a label on each package identifying the parts and where to use them.

Identifique y separete los accesorios utilizados en el montaje. Observe la etiqueta en cada paquete para saber donde montar.

Identifiez et séparez les accessoires à être utilisés. Dans chaque emballage il y a une étiquette pour identifier les pièces et où les utiliser.

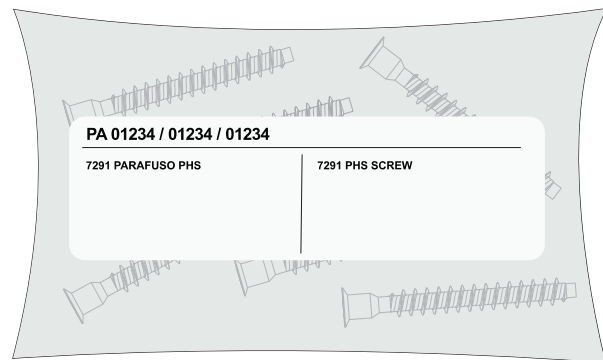









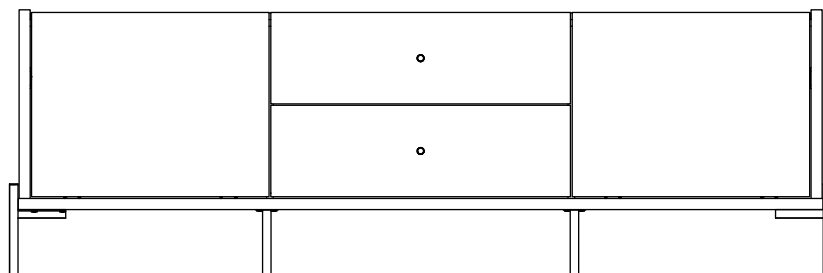

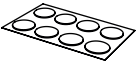

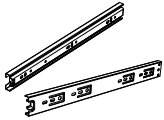
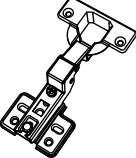

1852 mm

L:1852mm A:601mm P:443mm
W:72.92in H:23.67in D:17.45in
L:1852mm A:601mm P:443mm
L:1852mm H:601mm P:443mm

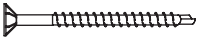
2202 mm

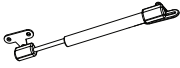
L:2202mm A:601mm P:443mm
W:86.70in H:23.67in D:17.45in
L:2202mm A:601mm P:443mm
L:2202mm H:601mm P:443mm



<p>A ADESIVO STICKER ADHESIVO AUTOCOLLANT AUFKLEBER (10X)</p> 	<p>B COD. 10063 (18X)</p> 	<p>C COD. 1668 6.0 x 30 (24X)</p> 	<p>D COD. 0342 (08X)</p> 	<p>E COD. 13579 (02X)</p> 
<p>F COD. 8903 (04X)</p> 	<p>G COD. 0599 (18X)</p> 	<p>H COD. 1533 4.0 x 14 (16X)</p> 	<p>I COD. 7519 4.5 x 16 (40X)</p> 	<p>J COD. 0715 4.5 x 50 (04X)</p> 
<p>K COD. 6533 5.0 x 25 (22X)</p> 	<p>L COD. 3187 M4 x 20 (02X)</p> 	<p>M COD. 10084 (04X)</p> 	<p>N PONTEIRA PLÁSTICA PLASTIC STOPPER ALMOHADILLA PLASTICO BOUCHON PLASTIQUE KUNSTSTOFFSTOPPER (06X)</p> 	<p>O COD. 0357 8.0 x 8.0 (44X)</p> 
<p>P PUXADOR DOOR HANDLE MANIJA POIGNÉE GRIFF (02X)</p> 				

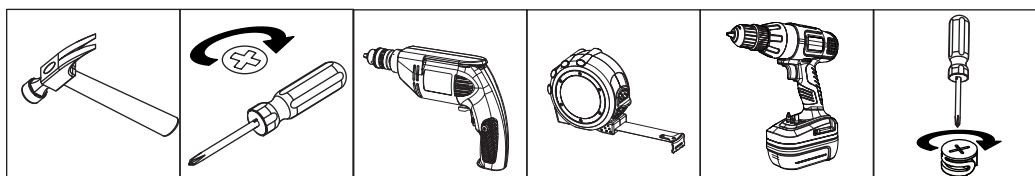

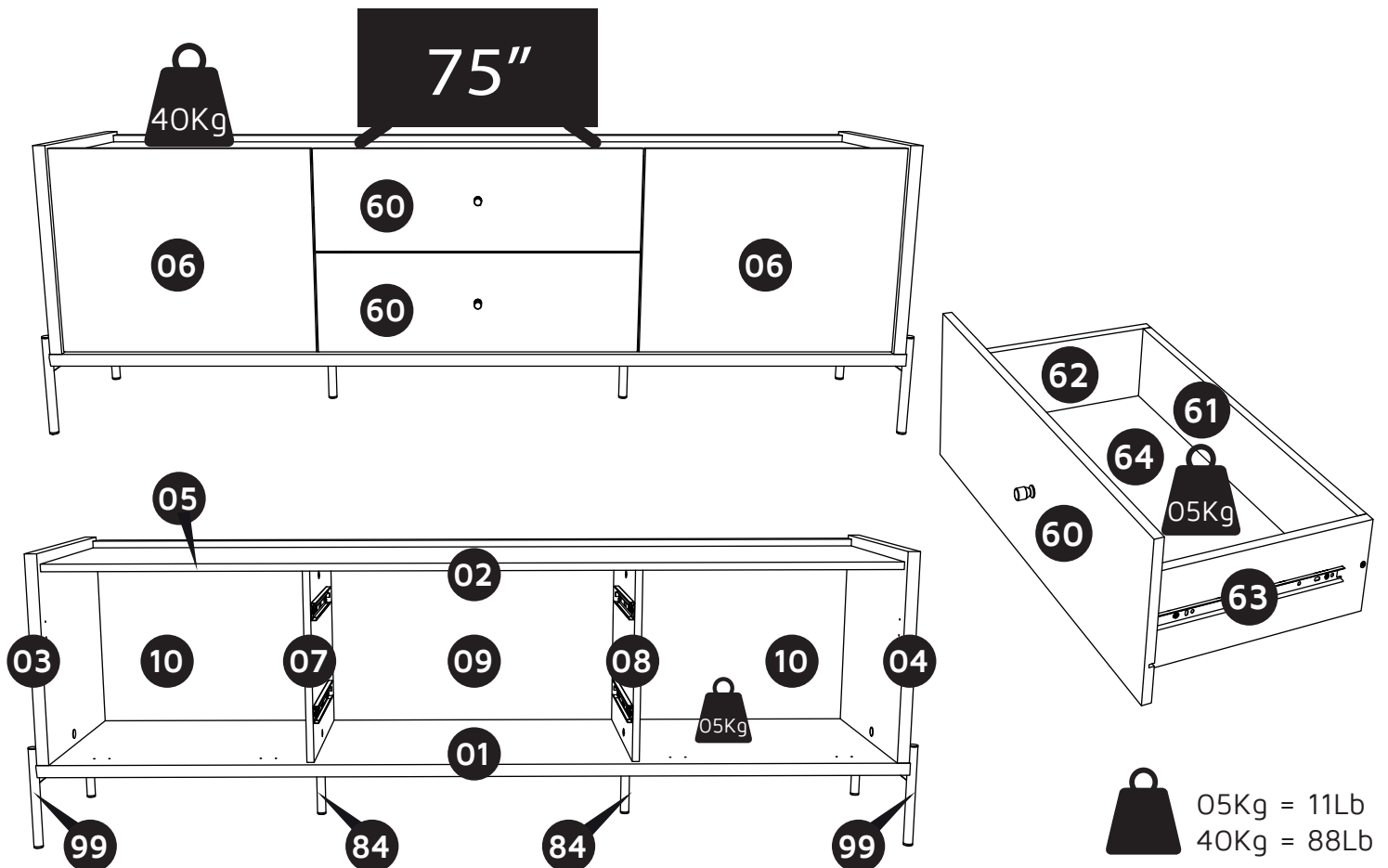

DESCRIÇÃO/ DESCRIPTION/ DESCRIPCIÓN/ DESCRIPTION

1852mm / 2202mm						
PEÇA PART PIEZA PIECE	QUANTIDADE QUANTITY CANTIDAD QUANTITÉ	DESCRIÇÃO	DESCRIPTION	DESCRIPCIÓN	DESCRIPTION	CAIXA BOX CAJA BOÎTE
01	01	BASE	BASE	BASE	BASE	01
02	01	TAMPO	TOP PANEL	PANEL SUPERIOR	PLATEAU	01
03	01	LATERAL ESQUERDA	LEFT SIDE	LATERAL IZQUIERDA	CÔTÉ GAUCHE	01
04	01	LATERAL DIREITA	RIGHT SIDE	LATERAL DERECHA	CÔTÉ DROITE	01
05	01	SARRAFO TRASEIRO	BATTEN REAR	SARRAFO TRASERO	LATTE DERRIÈRE	01
06	02	PORTA	DOOR	PUERTA	PORTE	01
07	01	DIVISÓRIA ESQ.	LEFT DIVIDER	DIVISION IZQUIERDA	DIVISEUR GAUCHE	01
08	01	DIVISÓRIA DIR.	RIGHT DIVIDER	DIVISION DERECHA	DIVISEUR FROIT	01
09	01	FUNDO CENTRAL	CENTER BACKPLATE	FONDO CENTRAL	FOND	01
10	02	FUNDO LATERAL	SIDE BACKPLATE	FONDO LATERAL	FOND	01
60	02	FRENTE GAVETA	DRAWER FRONT	FRENTE DEL CAJÓN	FAÇADE DE TIROIR	01
61	02	CONTRA FUNDO	LEFT DRAWER SIDE	CAJÓN LATERAL IZQ.	CÔTÉ DE TIROIR	01
62	02	LATERAL GAVETA ESQ.	RIGHT DRAWER SIDE	CAJÓN LATERAL DER.	CÔTÉ DE TIROIR	01
63	02	LATERAL GAVETA DIR.	DRAWER BACK PANEL	CAJÓN INFERIOR	DERRIÈRE	01
64	02	FUNDO GAVETA	DRAWER BOTTOM	FONDO DEL CAJÓN	FOND DE TIROIR	01
84	02	BASE AÇO CENTRAL	CENTER STEEL BASE	BASE ACERO CENTRAL	BASE EN ACIER	02
99	02	BASE DE AÇO	STEEL BASE	BASE DE ACERO	BASE EN ACIER	02



01

C COD. 1668	G COD. 0599
	

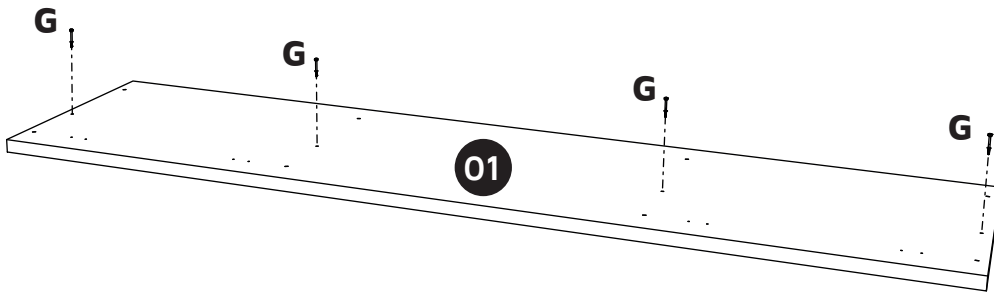

PASSO 01
Parafusar minifix 4x**0599**
na base **01**.

STEP 01
Screw minifix 4x**0599** on
base **01**.

PASO 01
Atornillar el minifix 4x**0599**
en la base **01**.

ÉTAPE 01
Vissez le minifix 4x**0599** dans
la base **01**.

02

PASSO 02
Encaixar cavilhas 4x**1668** e parafusar minifix
2x**0599** no tampo **02**.

PASO 02
Clavijas de ajuste 4x**1668** y atornillar el minifix
2x**0599** en el panel superior **02**.

STEP 02
Insert dowels 4x**1668** and screw minifix
2x**0599** on top panel **02**.

ÉTAPE 02
Insérez les chevilles 4x**1668** et vissez le minifix
2x**0599** sur les plateu **02**.

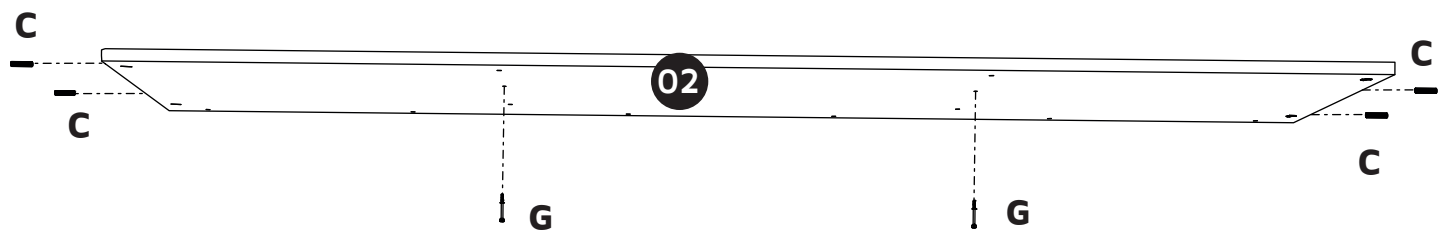

03

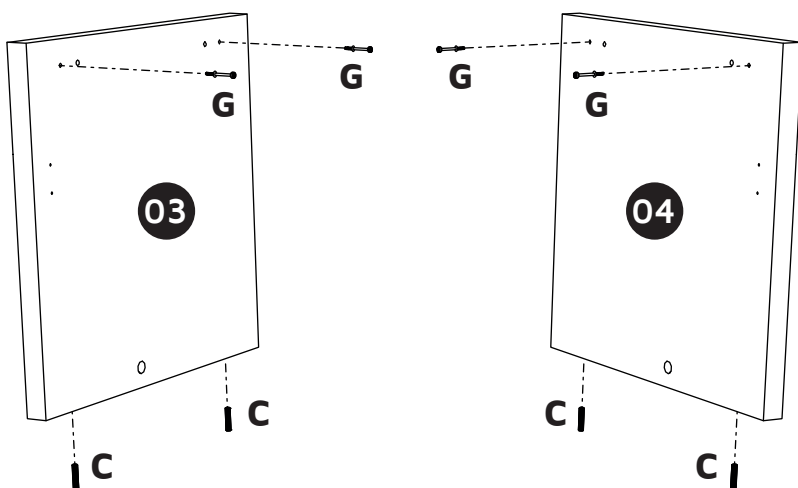

PASSO 03
Encaixar cavilhas 2x**1668** e parafusar
minifix 2x**0599** nas laterais **03/04**.

STEP 03
Insert dowels 2x**1668** and screw minifix
2x**0599** on the sides **03/04**.

PASO 03
Clavijas de ajuste 2x**1668** y atornillar
el minifix 2x**0599** en las laterales **03/04**.

ÉTAPE 03
Insérez les chevilles 2x**1668** et vissez
le minifix 2x**0599** sur les côtés **03/04**.

04

A	B	C	E	H
	COD. 10063 	COD. 1668 	COD. 2661 	COD. 1533

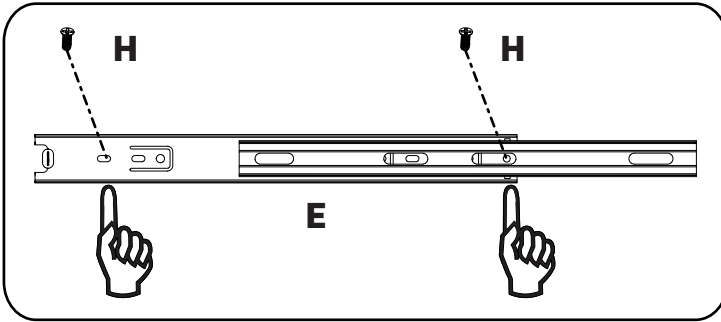

PASSO 04

Parafusar 4x**1533** as corredeiras 2x**2661** nas divisórias **07/08**.

STEP 04

Screw 4x**1533** the slides 2x**2661** on dividers **07/08**.

PASO 04

Atornillar 4x**1533** las correderas 2x**2661** en las divisiones **07/08**.

ÉTAPE 04

Vissez 4x**1533** les curseurs 2x**2661** sur les diviseurs **07/08**.

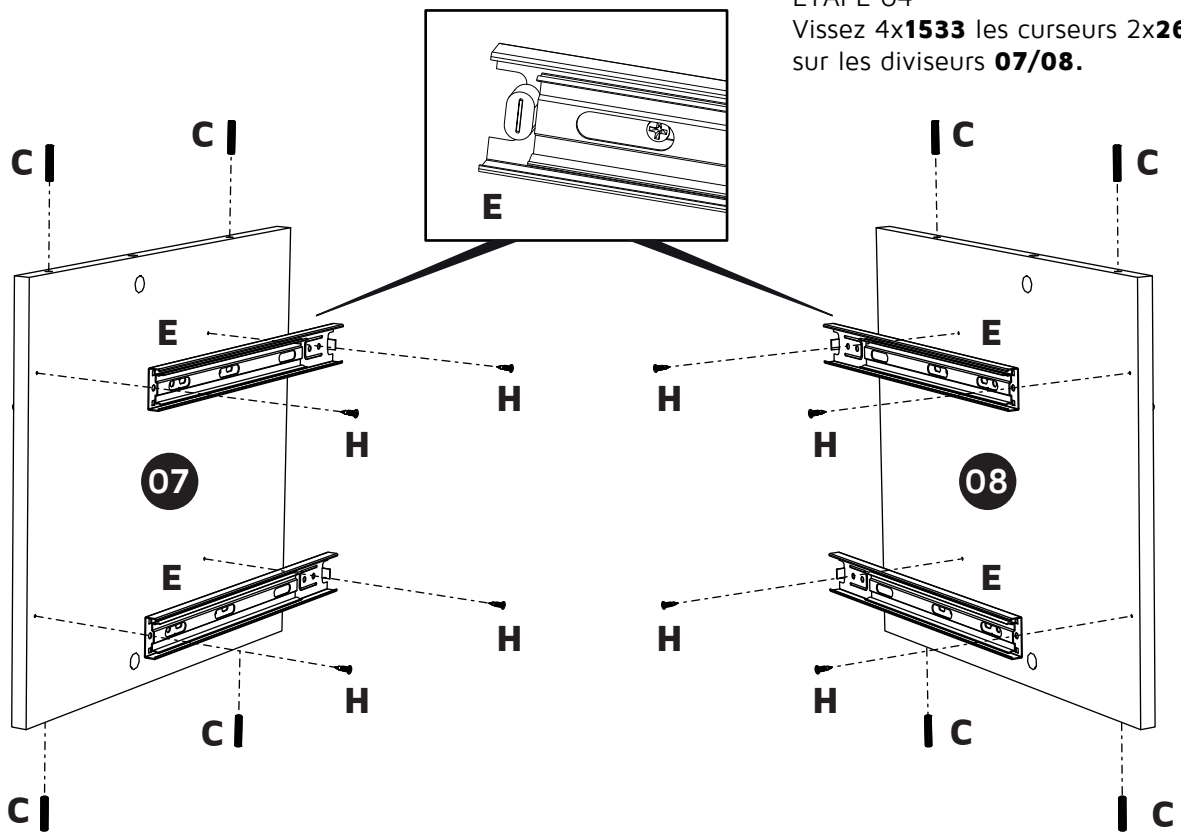

05

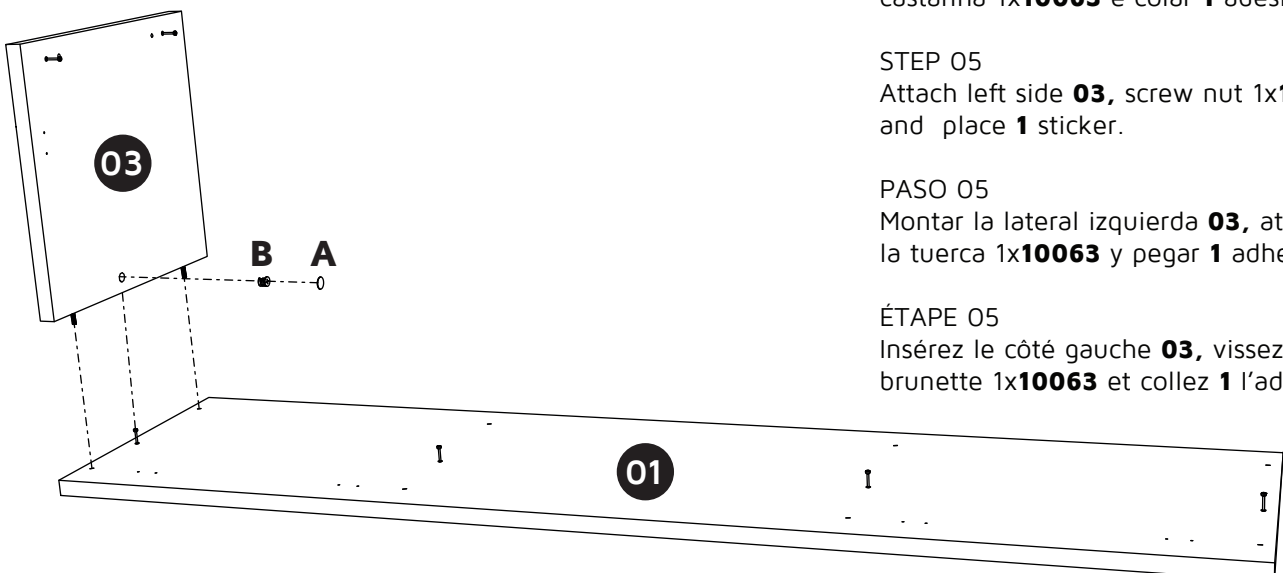

PASSO 05

Encaixar lateral esquerda **03**, parafusar castanha 1x**10063** e colar **1** adesivo.

STEP 05

Attach left side **03**, screw nut 1x**10063** and place **1** sticker.

PASO 05

Montar la lateral izquierda **03**, atornillar la tuerca 1x**10063** y pegar **1** adhesivo.

ÉTAPE 05

Insérez le côté gauche **03**, vissez le brunette 1x**10063** et collez **1** l'adhésif.

PASSO 06
Encaixar divisórias **07/08** e parafusar castanhas 2x**10063**.

PASO 06
Montar las divisiones **07/08** y atornillar las tuercas 2x**10063**.

STEP 06
Attach dividers **07/08** and screw nuts 2x**10063**.

ÉTAPE 06
Insérez les diviseurs **07/08** et vissez le brunette 3x**10063**.

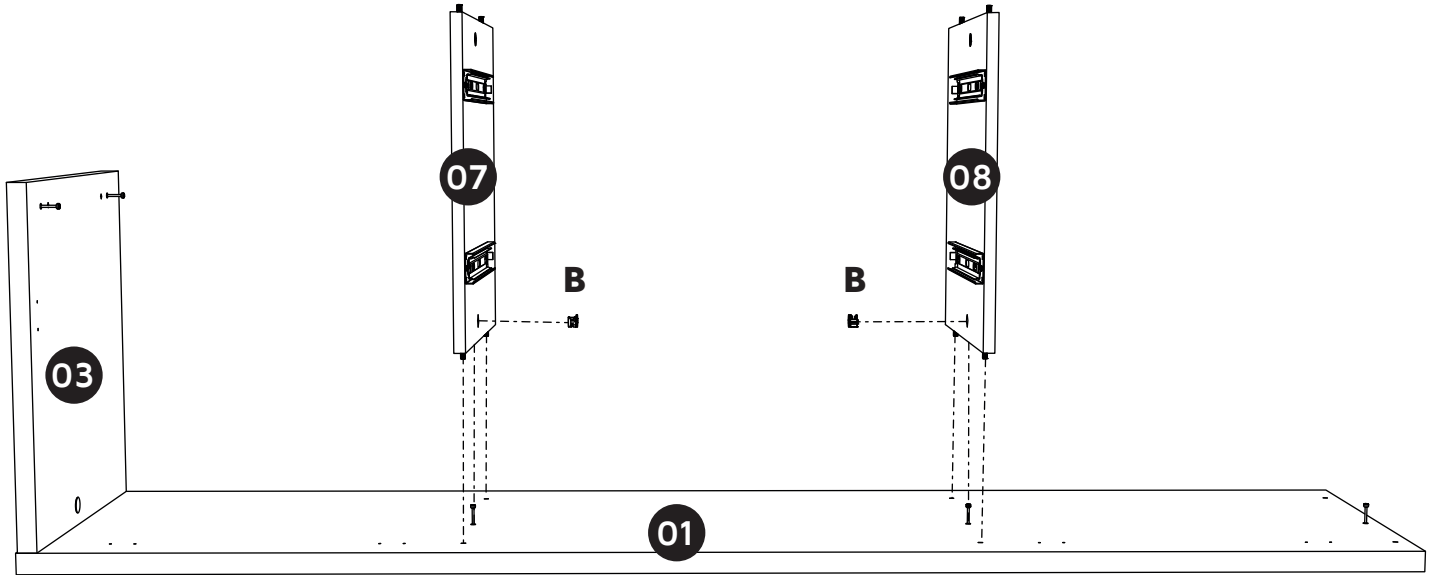

PASSO 07
Encaixar tampo **02** e parafusar castanhas 4x**10063**.

PASO 07
Montar el panel superior **02** y atornillar las tuercas 4x**10063**.

STEP 07
Attach top panel **02** and screw nuts 4x**10063**.

ÉTAPE 07
Insérez le plateau **02** et vissez le brunette 4x**10063**.

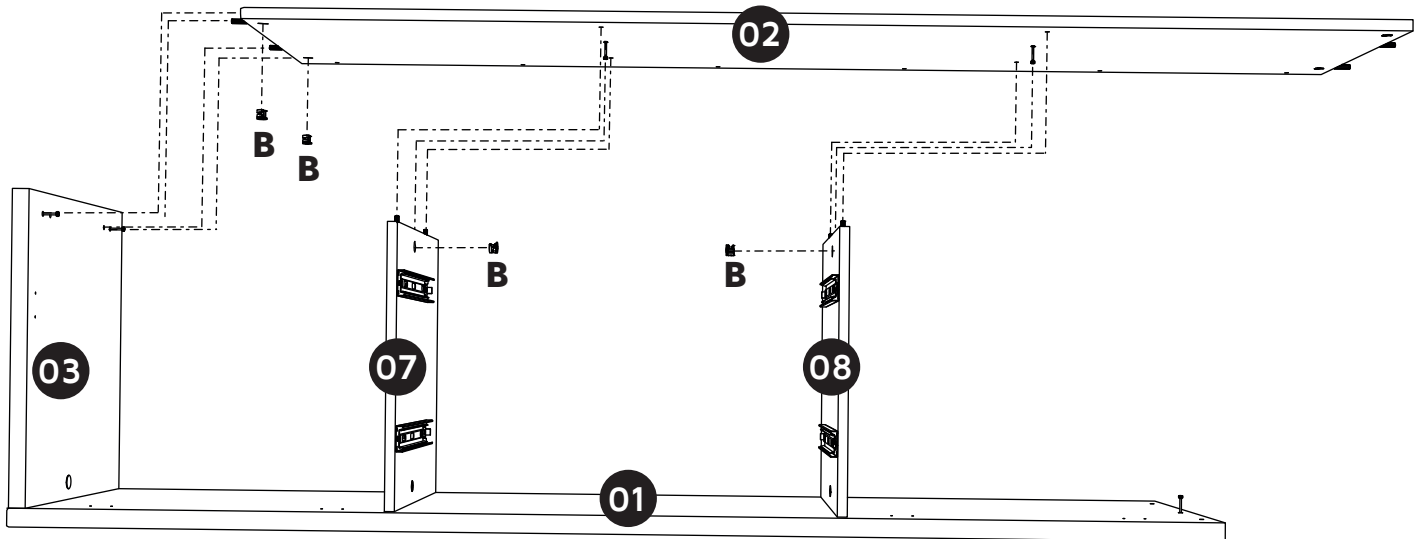

08

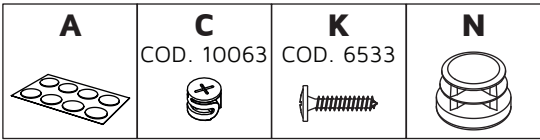

PASSO 08
Encaixar lateral direita **04**, parafusar castanhas 3x**10063** e colar **1** adesivo.

PASO 08
Montar lateral derecha **04**, atornillar las tuercas 3x**10063** y pegar **1** adhesivo.

STEP 08
Attach right side **04**, screw nuts 3x**10063** and place **1** sticker.

ÉTAPE 08
Insérez le côté droite **04**, vissez le brunette 3x**10063** et collez **1** l'adhésif.

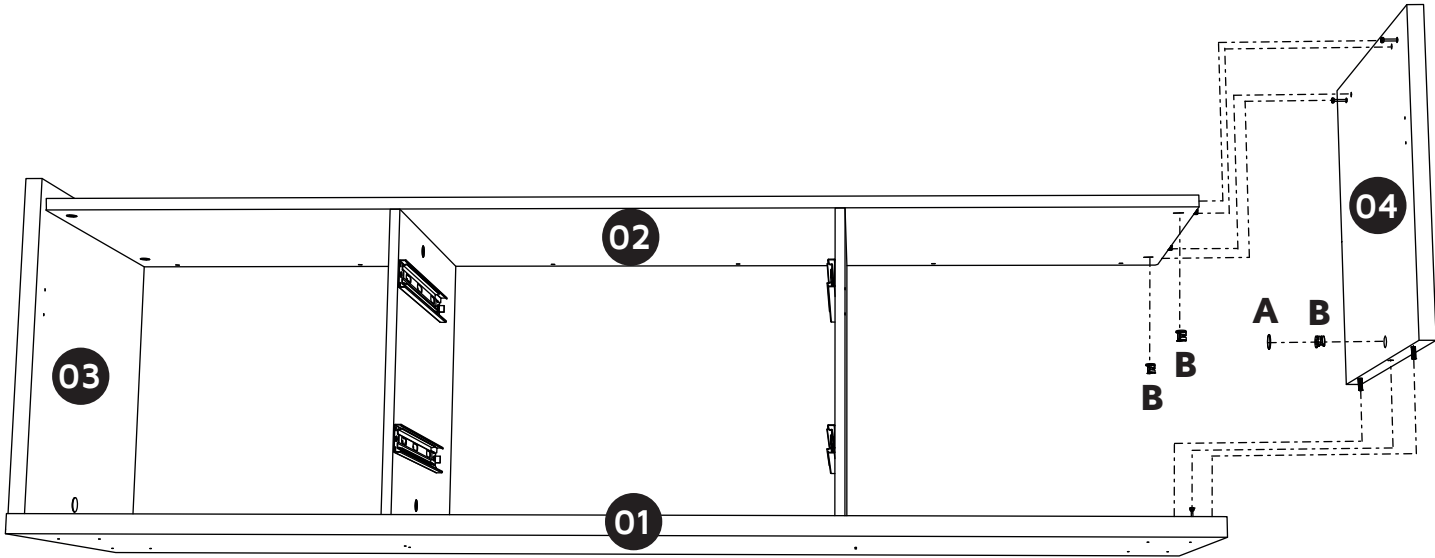

09

PASSO 09
Parafusar 4x**6533** base de aço **99**/ base central **84** na base **01** e encaixar sapata plástica.



PASO 09
Atornillar 4x**6533** base de acero **99**/ base de acero central **84** en la base **01** y enganchar almohadilla de plástico.

STEP 09
Screw 4x**6533** steel base **99**/ center steel base **84** on base **01** and insert plastic stopper.

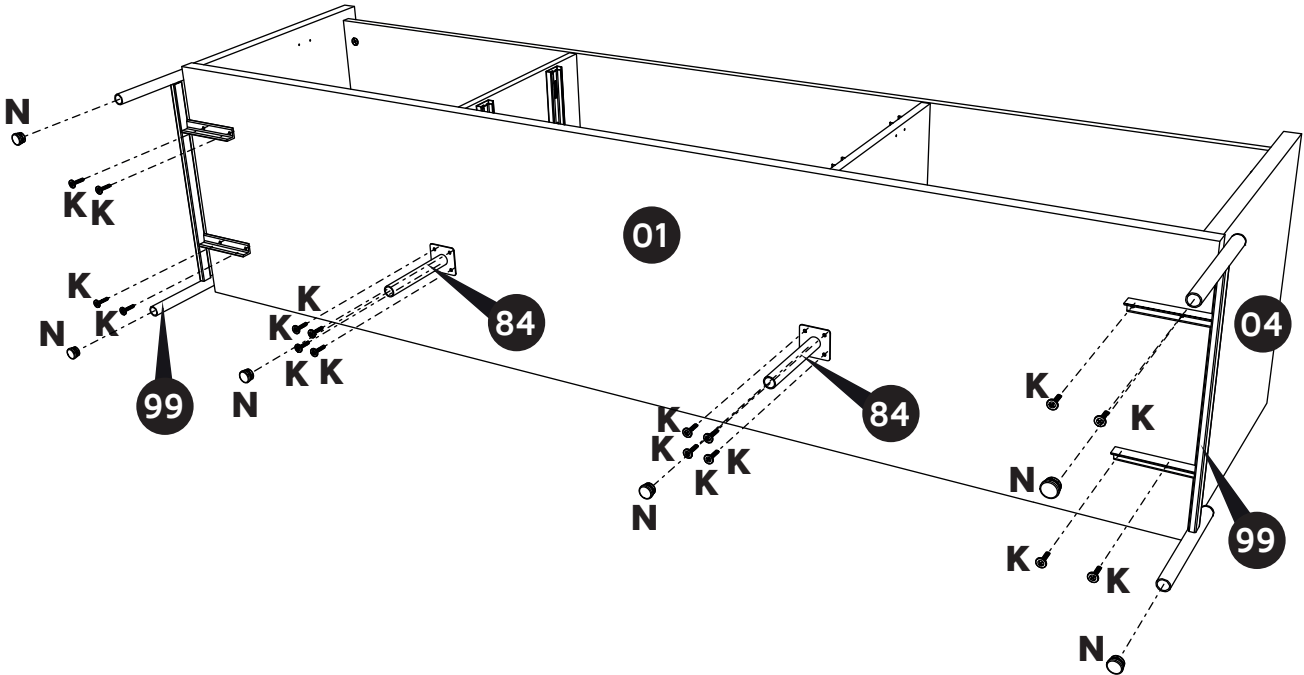
ÉTAPE 09
Vissez 4x**6533** base en acier **99**/ base centrale acier **84** dans la base **01** et insérez bouchon plastique.



10

D COD. 0342	K COD. 6533	O COD. 0357
		

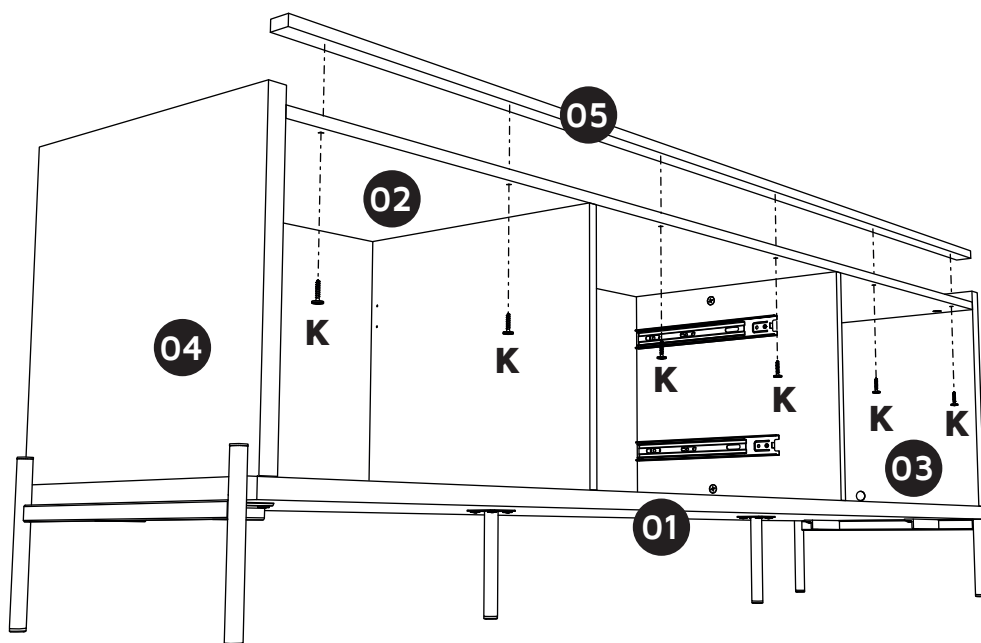

PASSO 10
Encaixar sarrafo **05** e
parafusar 6x**6533**.

STEP 10
Attach the batten **05**
and screw 6x**6533**.

PASO 10
Montar el sarrafo **05**
y atornillar 6x**6533**.

ÉTAPE 10
Insérez latte derrière **05**,
vissez 6x**6533**.

11

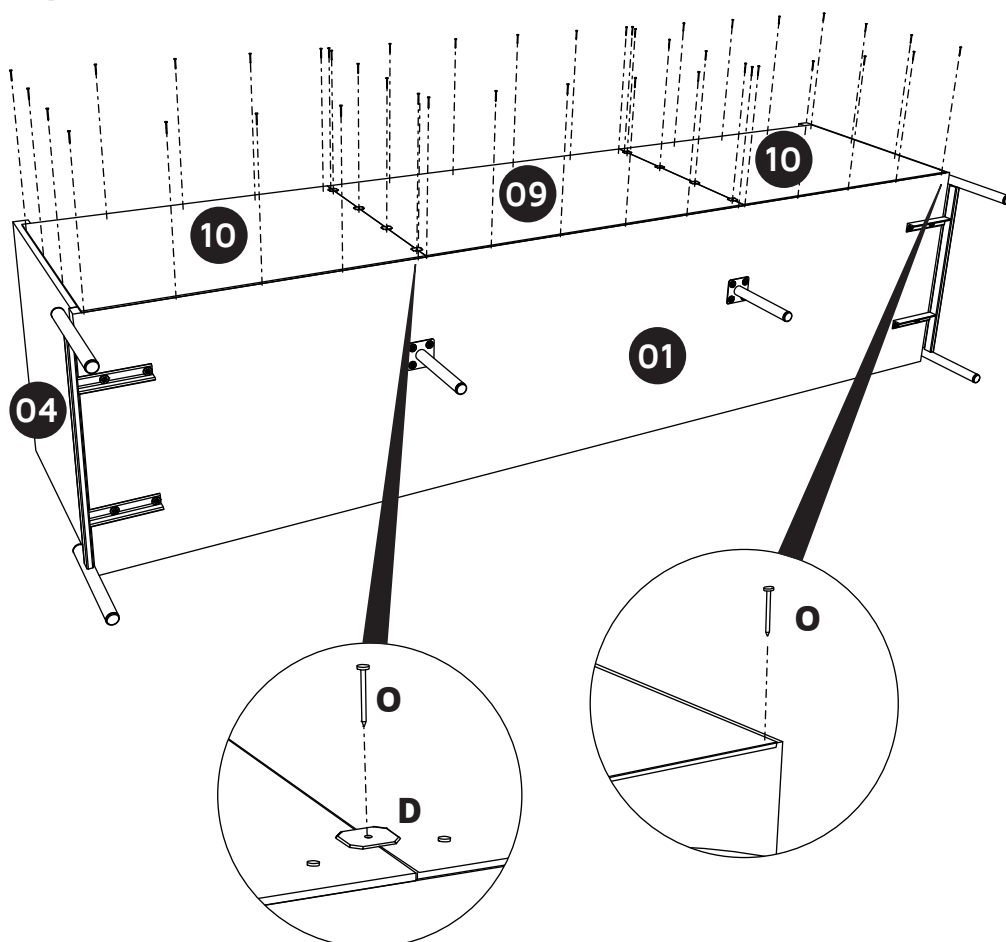

PASSO 11
Encaixar fundo **09/10**
e pregar **0342/0357**.

STEP 11
Attach backplate **09/10**
and nailing **0342/0357**.

PASO 11
Enganchar el fondo **09/10**
y clavar **0342/0357**.

ÉTAPE 11
Insérez le fond **09/10**
et clouer **0342/0357**.

12

PASSO 12
Encaixar dobradiças 2x**8903**
e parafusar 4x**7519**.

PASO 12
Montar las bisagras 2x**8903** y
atornillar 4x**7519**.

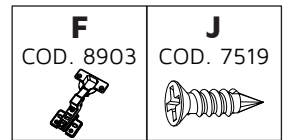

STEP 12
Attach the hinges 2x**8903** and
screw 4x**7519**.

ÉTAPE 12
Insérez les charnières 2x**8903** et
vissez 4x**7519**.

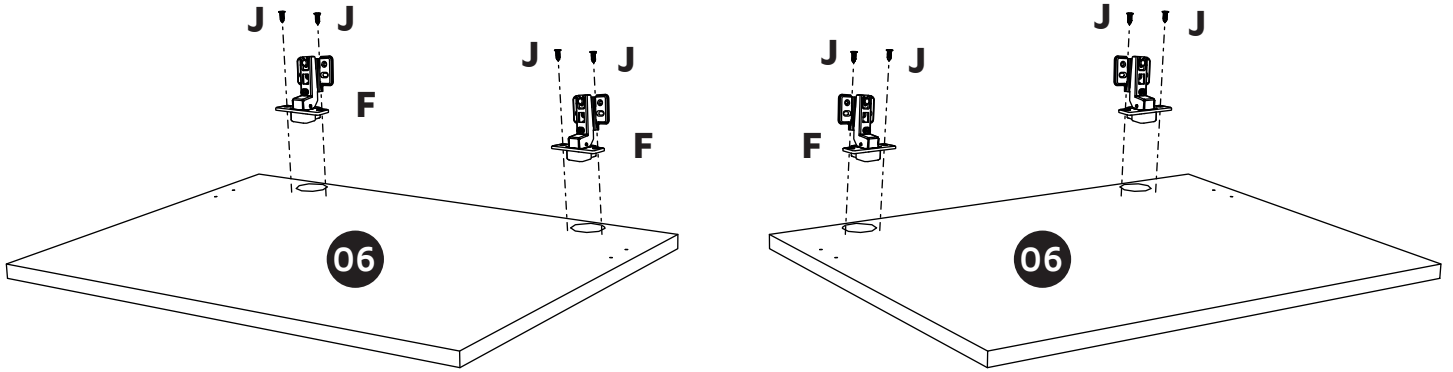

13

PASSO 13
Encaixar porta **06** e parafusar
8x**7519**.

PASO 13
Montar la puerta **06** y atornillar
8x**7519**.

STEP 13
Attach the door **06** and screw
8x**7519**.

ÉTAPE 13
Insérez porte **06** et vissez
8x**7519**.

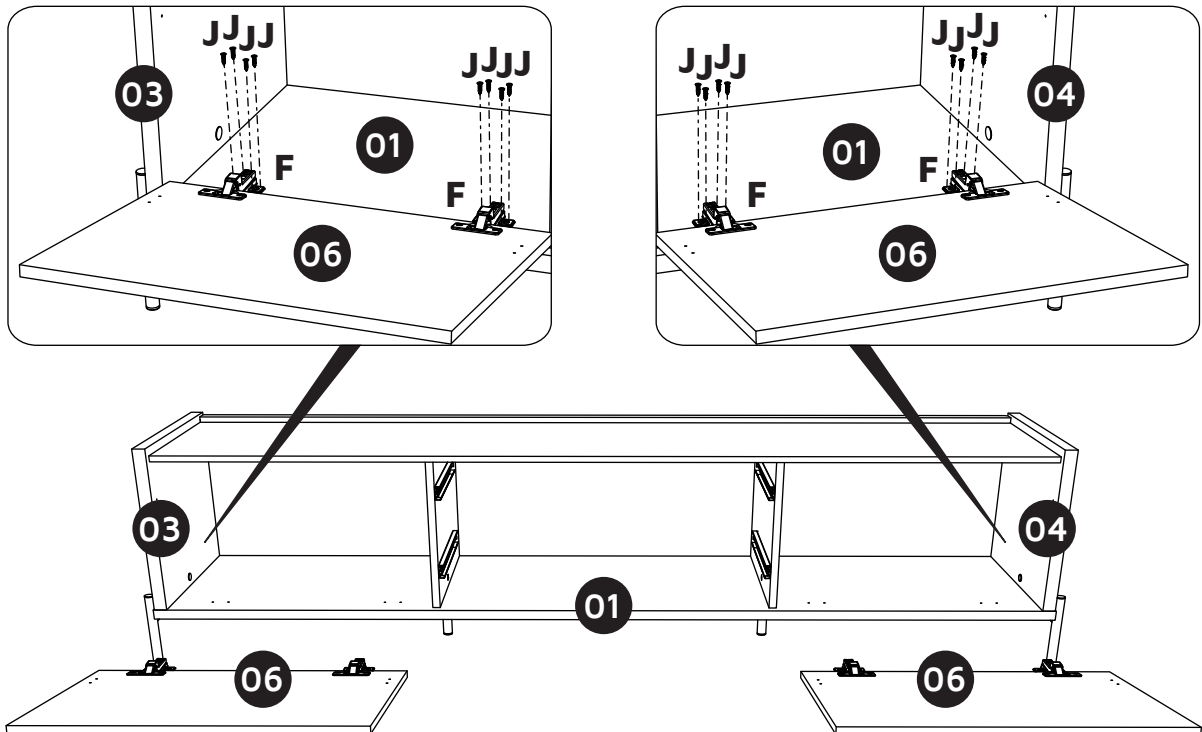

AJUSTE DAS DOBRADIÇAS
HINGE ADJUSTMENT
AJUSTE DE LAS BISAGRAS
RÉGLAGE DES CHARNIÈRES

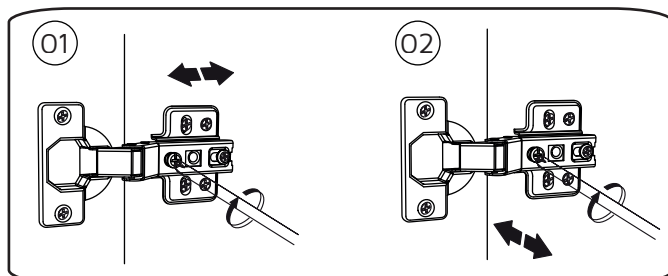

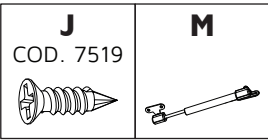

PASSO 14
Encaixar pistão e parafusar 4x**7519**.

PASO 14
Enganchar pistón y atornillar 4x**7519**.



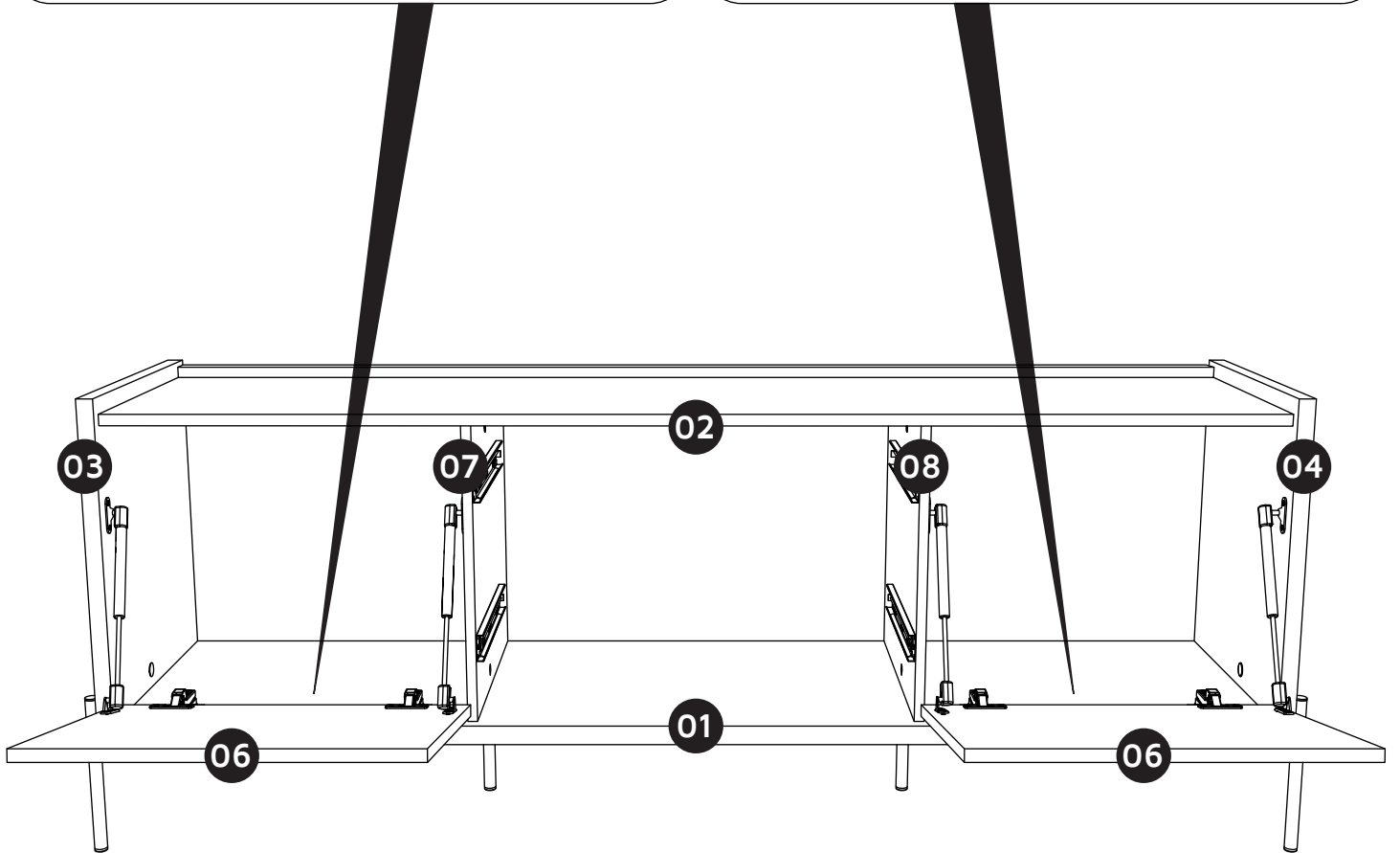
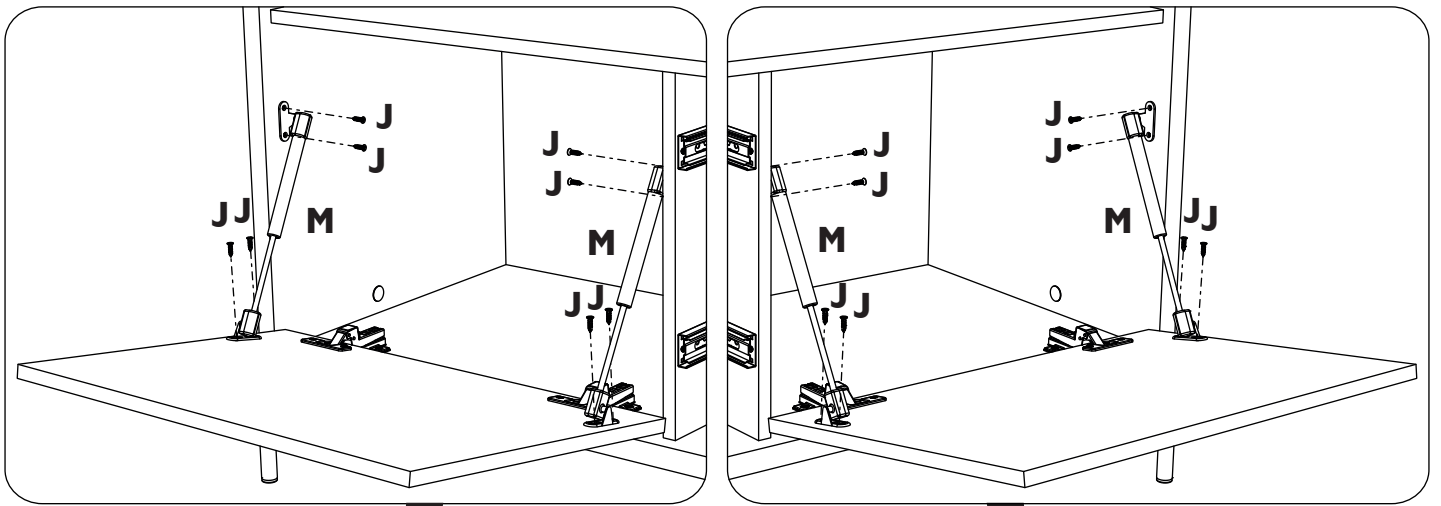

STEP 14
Attach piston and screw 4x**7519**.

ÉTAPE 14
Insérez piston et vissez 4x**7519**.

Atenção
Attention
Atención
Attention
Achtung



15

C COD. 1668 	E COD. 2661 	H COD. 1533 	J COD. 0715 
-------------------------------------------------------------------------------------------------------------	--------------------------------------------------------------------------------------------------------------	--------------------------------------------------------------------------------------------------------------	--------------------------------------------------------------------------------------------------------------

PASSO 15
Parafusar 4x**1533** as corredeiras 2x**2661** nas laterais gaveta esquerda e direita **62/63**.

PASO 15
Atornillar 4x**1533** las correderas 2x**2661** en los cajóns laterales izquierda y derecha **62/63**.

STEP 15
Screw 4x**1533** the slides 2x**2661** on the left and right drawer side **62/63**.

ÉTAPE 15
Vissez 4x**1533** les curseurs 2x**2661** sur les tiroir latéral gauche et droit **62/63**.

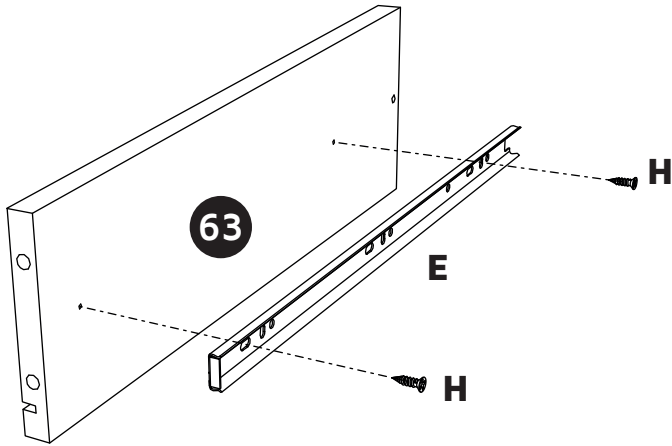
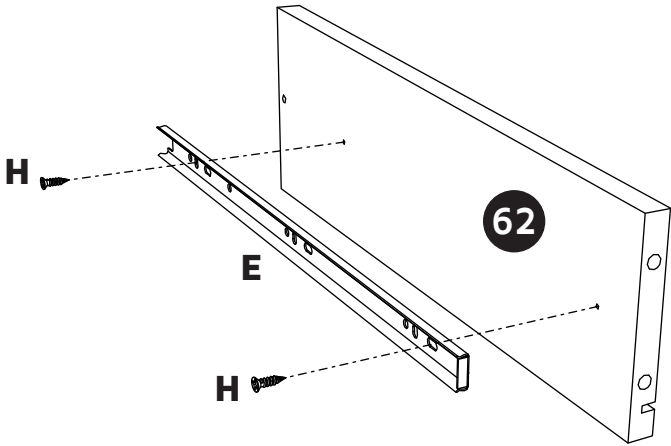

(2x)

16

PASSO 16
Encaixar cavilhas 4x**1668** no contra fundo **61**.
Encaixar laterais gaveta **61/62** e parafusar 2x**0715**.

PASO 16
Clavijas de ajuste 4x**1668** en cajón inferior **61**.
Montar cajóns laterales **61/62** y atornillar 2x**0715**.

STEP 16
Insert dowels 4x**1668** on drawer back panel **61**.
Attach drawer sides **61/62** and screw 2x**0715**.

ÉTAPE 16
Insérez les chevilles 4x**1668** derrière **61**.
Insérez tiroir latéral **61/62** et vissez 2x**0715**.

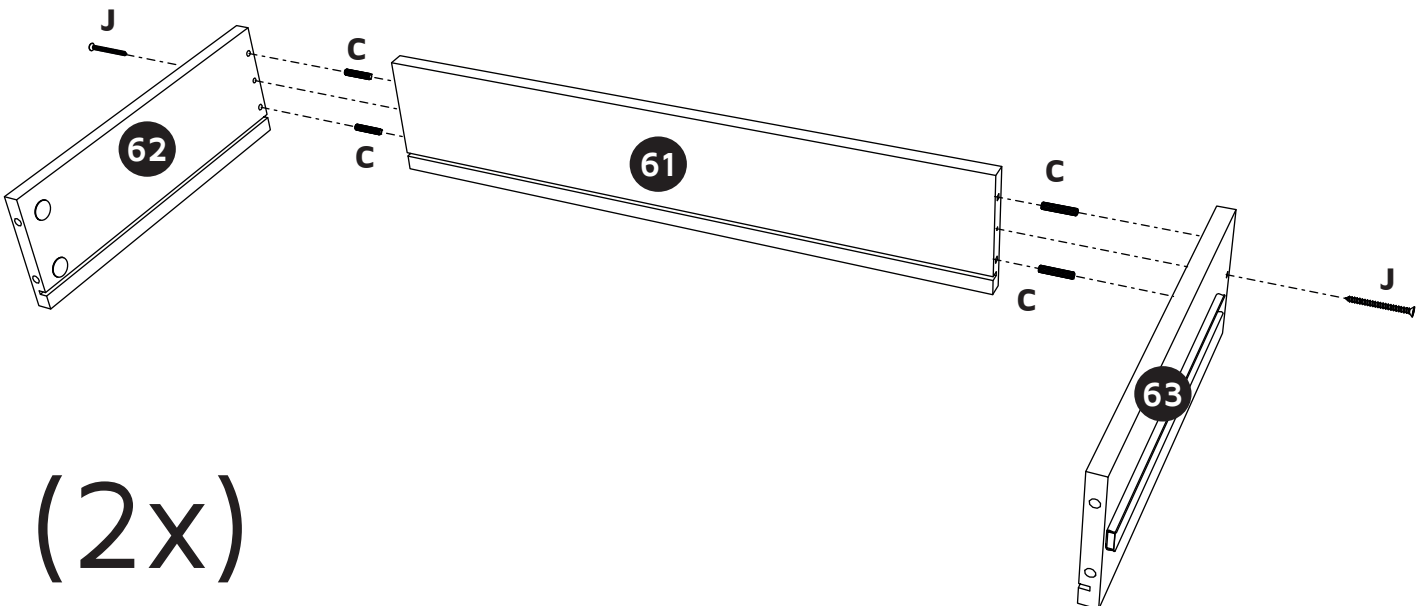

(2x)

17

A 	C COD. 10063 	G COD. 0599 	L COD. 3187 	P
--------------	----------------------------	---------------------------	---------------------------	--------------

PASSO 17
Encaixar fundo gaveta **64**.

STEP 17
Attach drawer bottom **64**.

PASO 17
Montar fondo del cajon **64**.

ÉTAPE 17
Insérez fond de tiroir **64**.

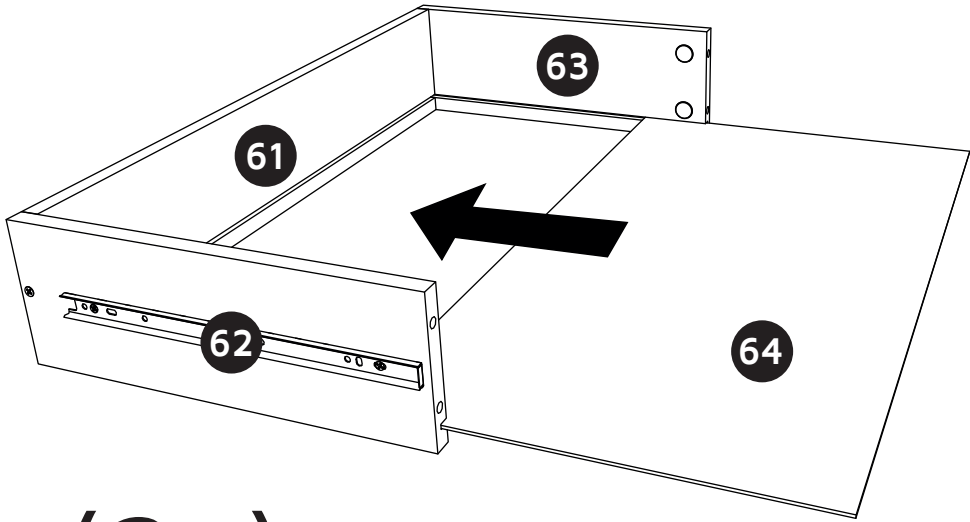

(2x)

18

PASSO 18
Parafusar minifix 4x**0599** e 1x**3187** o puxador na frente gaveta **60**. Encaixar nas laterais **62/63**, parafusar castanhas 4x**10063** e colar **4** adesivos.

STEP 18
Screw minifix 4x**0599** and 1x**3187** the door handle on drawer front **60**. Attach on sides **62/63**, screw nuts 4x**10063** and place **4** stickers.

PASO 18
Atornillar el minifix 4x**0599** y 1x**3187** el manija en la frente del cajón **60**. Montar en las laterales **62/63**, atornillar las tuercas 4x**10063** y pegar **4** adhesivo.

ÉTAPE 18
Vissez le minifix 4x**0599** et 1x**3187** dans poignée dans la façade de tiroir **60**. Insérez dans côtés **62/63**, vissez le brunette 4x**10063** et collez **4** l'adhésif.

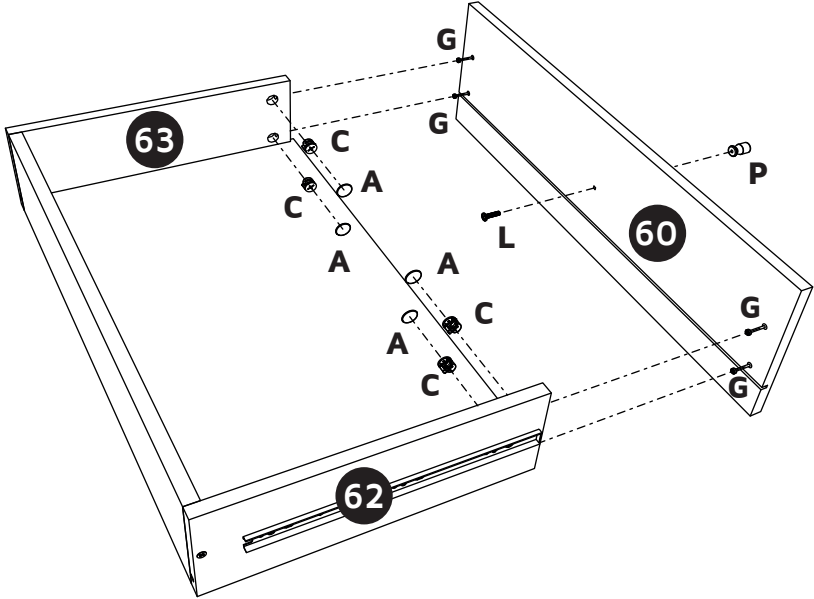

(2x)

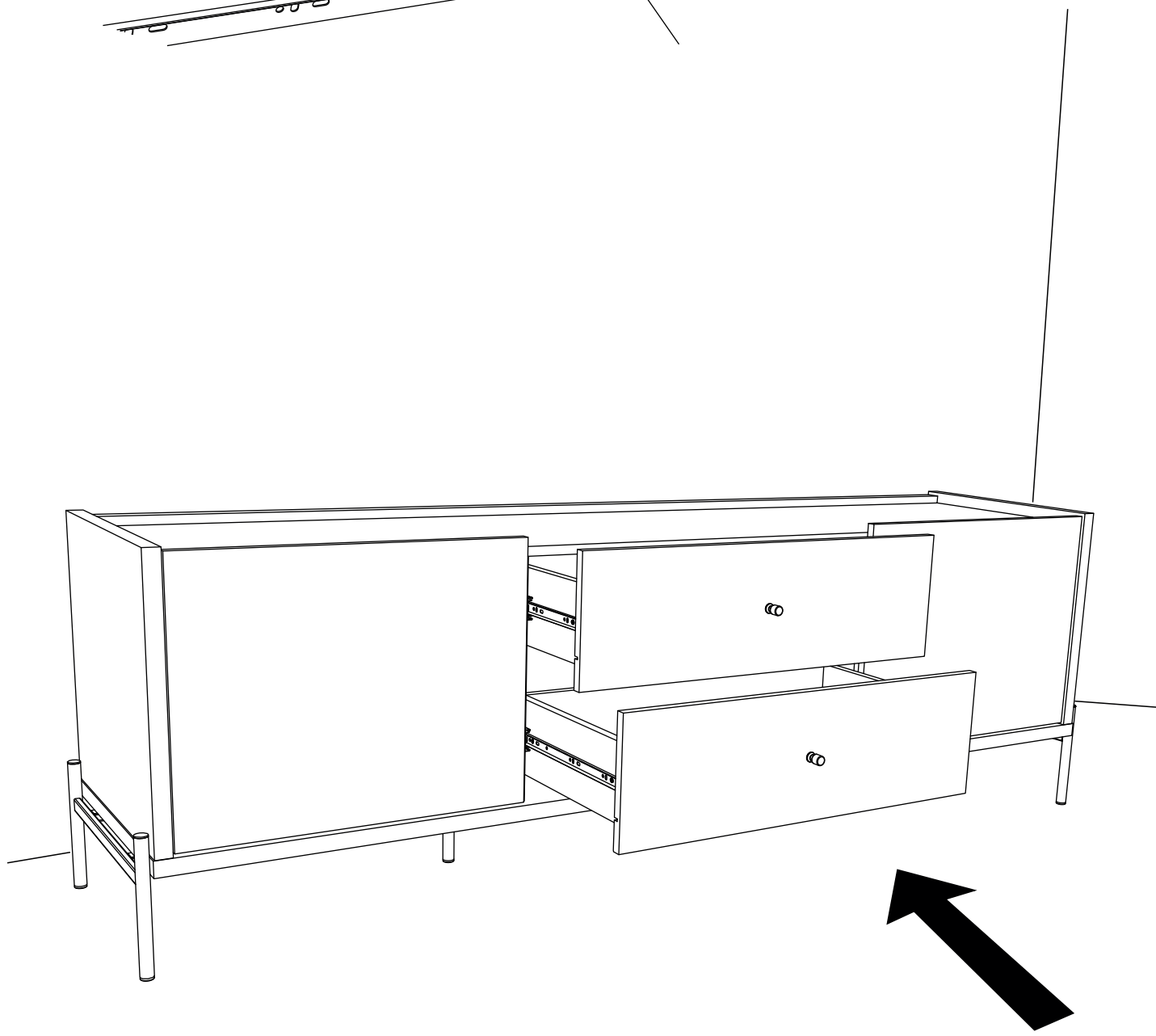
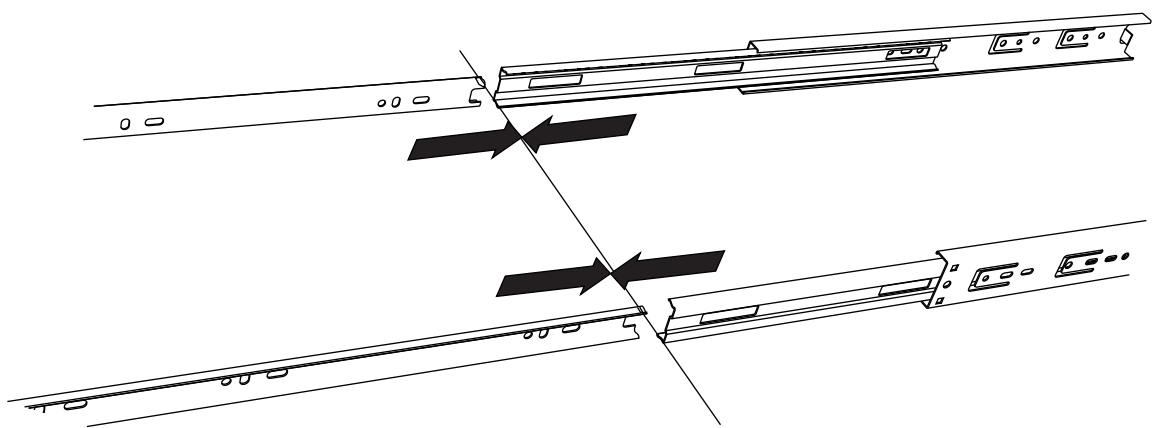

Agora que você já comprou o seu móvel, ele merece ser montado do jeito certo.

Erros de montagem causam mais de **60%** dos danos em móveis.

Por que contratar?

Tranquilidade do **início ao fim** da montagem



PROFISSIONAIS QUALIFICADOS

Especialistas certificados na **MadeiraMadeira Serviços**.



FERRAMENTAS PROFISSIONAIS

que **protegem** seus móveis.



AGENDAMENTO EM 24 HORAS

escolha a data e o turno **ideais para** você.



GARANTIA DE 3 MESES

de cobertura **completa**.

Mais de 1 MILHÃO DE MONTAGENS
★ com avaliação 4.7 ★

Mariana S., São Paulo

"Chegaram no horário e montaram tudo rapidamente. Serviço incrível!"



Carlos R., Belo Horizonte

"Tentei montar sozinho e foi um desastre. Com a **MadeiraMadeira Serviços** ficou perfeito."



Ana P., Rio de Janeiro

"Agendamento ágil e **montagem pontual e perfeita**. Recomendo demais!"



Agende agora pelo
QR Code

Madeira**Madeira** Serviços · Atendimento em todo o Brasil



Escaneie o QRCode