



MAVAULAR móveis

Fone (32) 3539-7600

Rod. Ubá - Rodeiro, Km 03 - Galpão 1

C. P. 050 - CEP 36500-000 - Ubá - MG

E-mail: mavaular@mavaular.com.br - Site: www.mavaular.com.br

Mavaular Móveis



Instruções de Montagem Cabeceira Lyon

Assembly Instructions Lyon headboard

Instrucciones de montaje Cabecera Lyon

CÓDIGO: Painel lateral: 11107 / Painel extensão: 11119

Atualizado em:
16/03/2023

CUIDE BEM DO SEU MÓVEL

Dicas de limpeza e conservação:

- Para limpar corretamente seu produto, use sempre um pano liso e **levemente** umedecido com água;
- Não se esqueça de enxugar o seu móvel! Ele não deve permanecer úmido, pois a água pode prejudicar o acabamento ou causar mofo na madeira;
- Não se recomenda o uso de produtos à base de amoníaco.
- Não utilize esponja de aço ou qualquer material que possa arranhar a superfície do produto durante a limpeza.
- Não utilize plásticos ou papéis coloridos para forrar seu móvel.
- Evite arrastar objetos em cima do móvel. Eles podem riscar e prejudicar o acabamento de seu móvel de
- O material dos seus móveis tem um tratamento contra fungos e cupins, mesmo assim, em ambientes infestados recomenda-se a dedetização antes de instalar a seu móvel;
- Tente evitar a exposição direta ao sol. Sugere-se utilização de cortinas para proteger seu móvel;

TAKING GOOD CARE OF YOUR FURNITURE

Cleaning and caring instructions:

- Wipe the wood furniture down with a moist cloth to properly clean the furniture.
- Do not forget to dry your furniture out. Humidity can damage the finish or create mould.
- Chemical products are not recommended;
- Never clean the furniture with scouring powders, steel scrubber pads or any other product which can scratch its surface.
- Furniture surfaces should not be covered with colored plastic or paper sheets.
- Avoid dragging objects on top of the furniture. They might scratch the finishing.
- Wood furniture are made of mould and termites resistant materials, however, it is recommended to use termiticides in infested places before installing the furniture.
- Avoid furniture exposure to direct Sun light. Drapers suggested.

CUIDE BIEN DE SU MUEBLE

Indicaciones de limpieza y conservación

- Para limpiar correctamente su muebles de madera, siempre use un paño húmedo.
- No se olvide de secar su muebles! No debe permanecer húmedo, pues el agua puede perjudicar el acabado o causar moho en la madera.
- No es recomendable utilizar productos con amoníaco.
- No utilizar esponjas de acero o cualquier material que dañe la superficie de los muebles.
- No utilizar plásticos o papeles coloridos para forrar los muebles.
- Evite arrastrar objetos encima de los muebles. Ellos pueden riscar o dañar el acabado de su mueble de cocina.
- El material de los muebles tiene un tratamiento contra los hongos y las polillas, aun así, en ambientes infectados, se recomienda desinfectar antes de instalar su mueble.
- Evite la exposición directa al sol. Se sugiere la utilización de cortinas para proteger sus muebles.

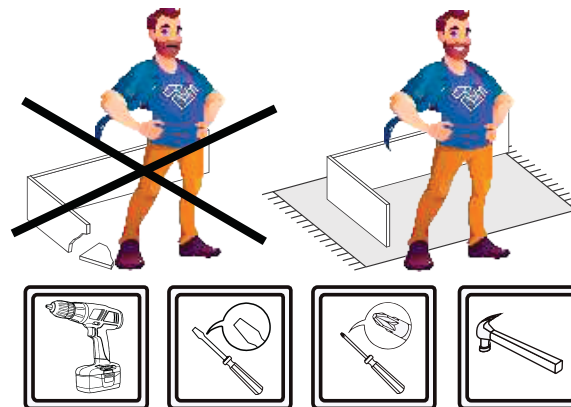

As ferramentas necessárias para montagem do produto não são fornecidas.
The necessary tools for assembly aren't supplied.
Las herramientas necesarias para armar los productos no son fornecidas.

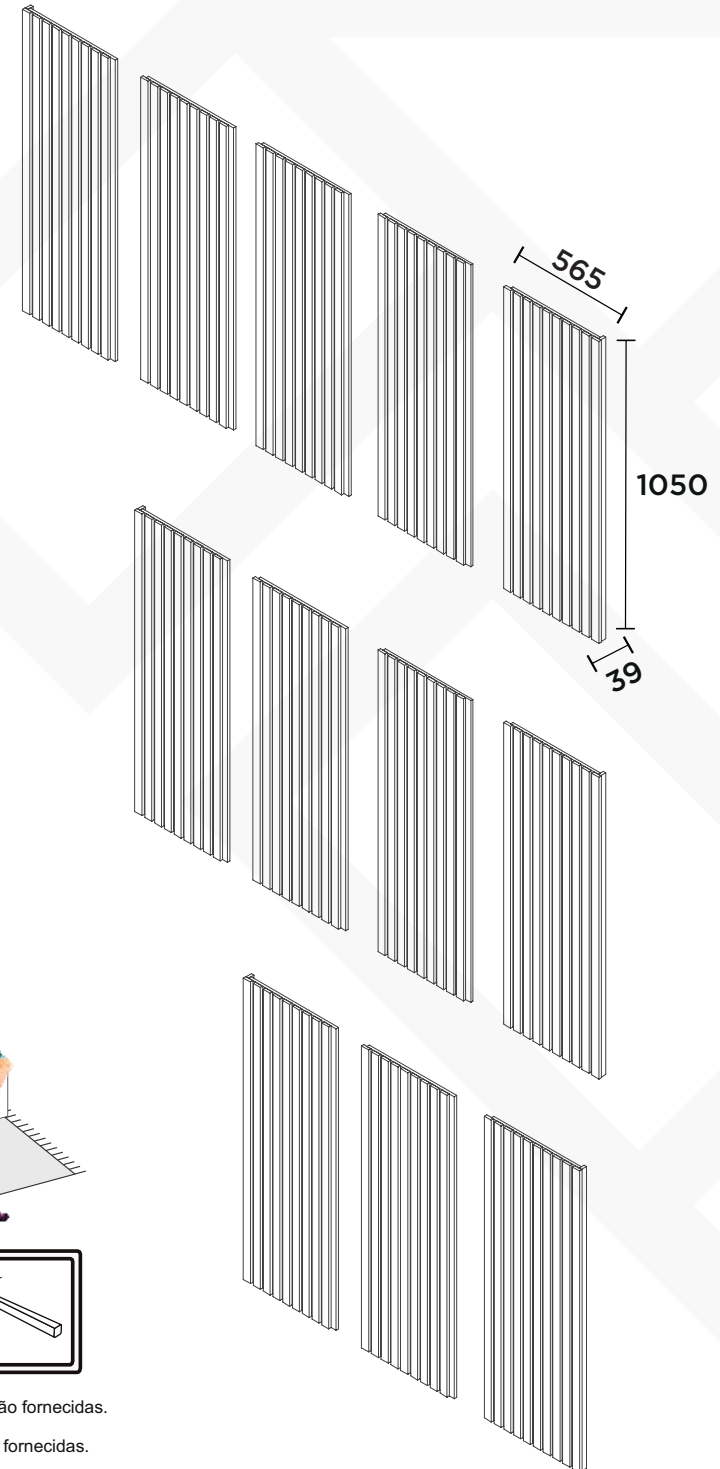

N°	CÓDIGO CODE CÓDIGO	DESCRIÇÃO DESCRIPTION DESCRIPCIÓN	DIMENSÃO (mm) DIMENSION (mm) DIMENSIÓN (mm)			QUANTIDADE QUANTITY CANTIDAD		
			COMP. LEN. LON.	LARG. WID. ANC.	ESP. DEP. ESP.			
PAINEL LATERAL								
1	11628	Painel lateral	Side panel	Panel lateral	1050	565	24	2
2	11117	Moldura do painel	Panel frame	Marco del panel	500	70	15	4
3	11540	Ripa acabamento da união	Union finishing frame	Marco de acabado de la unión	1050	36	12	1
4	11340	Gabarito	Spacer	Separador	1000	14	3	1
5	11116	Moldura fechamento lateral	Lateral closing frame	Marco de cierre lateral	1050	26	12	2
6	11109	Moldura da parede	Wall frame	Marco de pared	500	70	15	4
PAINEL EXTENSÃO								
7	11629	Painel extensão	Extension panel	Panel de extensión	1050	565	24	1
2	11117	Moldura do painel	Panel frame	Marco del panel	500	70	15	2
6	11109	Moldura da parede	Wall frame	Marco de pared	500	70	15	2

PAINEL LATERAL (x2)

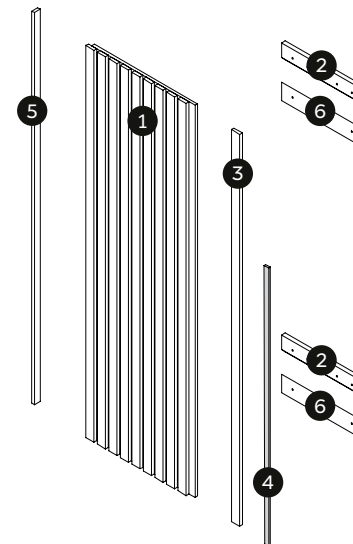

PAINEL LATERAL (x2)

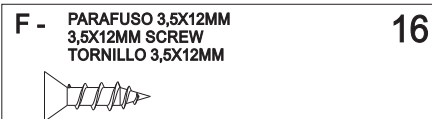
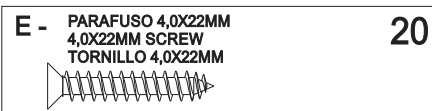
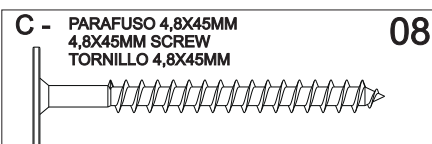

PAINEL EXTENSÃO

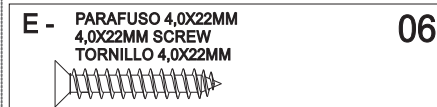
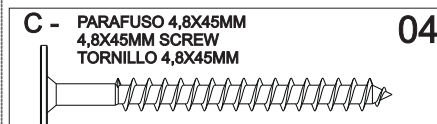

KIT OPCIONAL

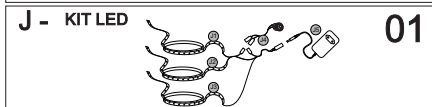

PAINEL EXTENSÃO

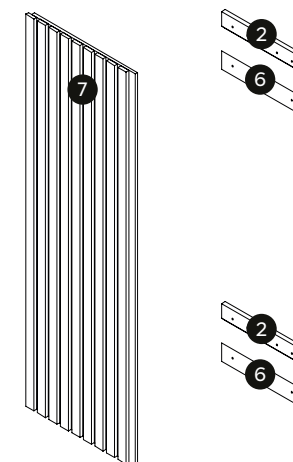

1

Aplicar cola na peça 2.
Apply glue to part 2.
Aplicar pegamento la pieza 2.

A x04 D x01

2

D x06

E x06

3 **!** **SOMENTE PARA PAINEL LATERAL**
ONLY FOR SIDE PANEL
SOLO PARA PANEL LATERAL

USAR O GABARITO PARA FIXAR CORRETAMENTE A PEÇA 3.
USE THE TEMPLATE TO CORRECTLY ATTACH PART 3.
UTILICE LA PLANTILLA PARA ADJUNTAR CORRECTAMENTE LA PARTE 3.

E x04

E x04

4 **!** **SOMENTE PARA PAINEL LATERAL**
ONLY FOR SIDE PANEL
SOLO PARA PANEL LATERAL

F+G x08

F x16 G x08

5

- Ø 8 mm (5/16 ").
- ∇ 50mm (1.96 ").

!
Atenção!
Medida especificada entre os centros dos furos.
Attention!
Specified measurement between the centers of the holes.
¡Atención!
Medida especificada entre los centros de los agujeros.

838mm

PAREDE WALL PARED

5.1

- Ø 8 mm (5/16 ").
- ∇ 50mm (1.96 ").

!

REPETIR A ETAPA 5 DE ACORDO COM A QUANTIDADE DE MÓDULOS ADQUIRIDOS.
REPEAT STEP 5 ACCORDING TO THE QUANTITY OF MODULES PURCHASED.
REPETIR EL PASO 5 SEGÚN LA CANTIDAD DE MÓDULOS COMPRADOS.

PAREDE WALL PARED

6

PAREDE WALL PARED

G x04

B x04

6.1

G

PAREDE WALL PARED

!

REPETIR A ETAPA 6 DE ACORDO COM A QUANTIDADE DE MÓDULOS ADQUIRIDOS.
REPEAT STEP 6 ACCORDING TO THE QUANTITY OF MODULES PURCHASED.
REPETIR EL PASO 6 SEGÚN LA CANTIDAD DE MÓDULOS COMPRADOS.

7

C x04

PAREDE WALL PARED

!

REPETIR A ETAPA 7 DE ACORDO COM A QUANTIDADE DE MÓDULOS ADQUIRIDOS.
REPEAT STEP 7 ACCORDING TO THE QUANTITY OF MODULES PURCHASED.
REPETIR EL PASO 7 SEGÚN LA CANTIDAD DE MÓDULOS COMPRADOS.

C x04

8

**SOMENTE PARA MONTAGEM COM KIT LED OPCIONAL.
ONLY FOR ASSEMBLY WITH OPTIONAL LED KIT.
SOLO PARA MONTAJE CON KIT LED OPCIONAL.**

RETIRE A PELÍCULA PROTETORA DA FITA DUPLA FACE E INICIE A COLAGEM DA FITA DE LED NO CANAL DA PEÇA 1.

REMOVE THE PROTECTIVE FILM FROM THE DOUBLE-SIDED TAPE AND START ATTACHING THE LED TAPE IN THE CHANNEL OF PART 1.

RETIRE LA PELÍCULA PROTECTORA DE LA CINTA DE DOBLE CARA Y COMIENCE A FIJAR LA CINTA LED EN EL CANAL DE LA PARTE 1.

Dica:
Nessa etapa, passe todas as fiações necessárias.

Consejo:
En este paso, pase todo el cableado necesario.

Tip:
In this step, pass all the necessary wiring.

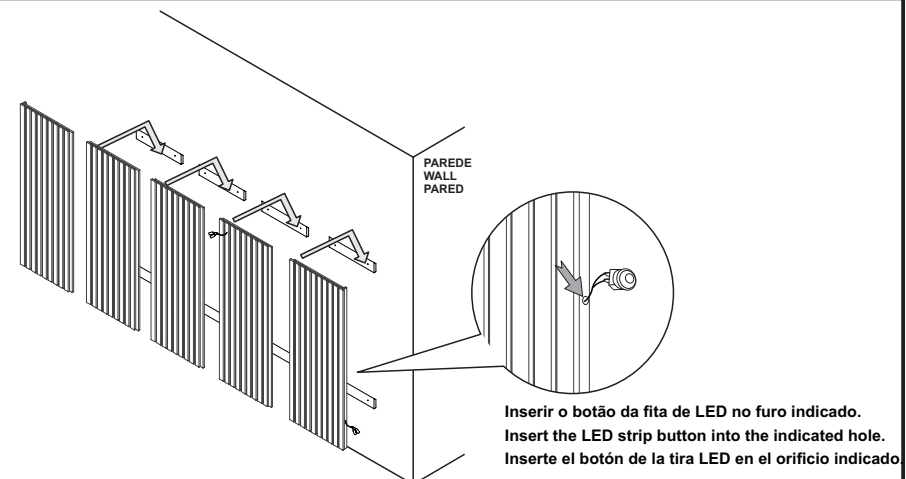
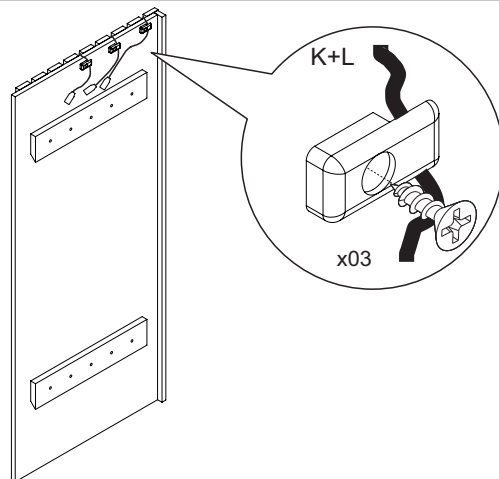
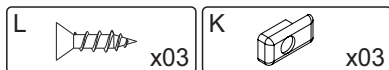

Inserir o botão da fita de LED no furo indicado.
Insert the LED strip button into the indicated hole.
Inserte el botón de la tira LED en el orificio indicado.

9**KIT LED OPCIONAL**

Após instalar a fita de Led. Encaixar o perfil de acabamento do Led.
After installing the LED strip. Fit the LED finishing profile.
Después de instalar la tira de LED. Montar el perfil de acabado LED.

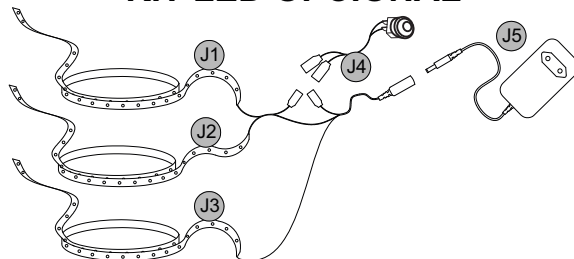
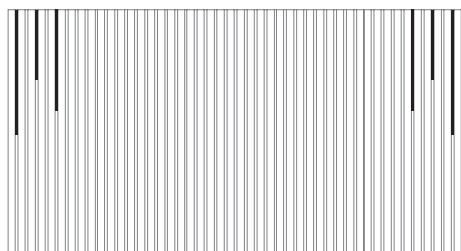

Instalado nos painéis laterais.
Installed on the side panels.
Instalado en los paneles laterales.

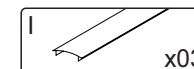
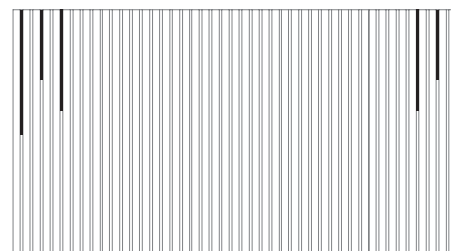
**10**

OPÇÕES DE MEDIDAS DE MONTAGEM | MOUNTING MEASUREMENTS OPTIONS | OPCIONES DE MEDIDA DE MONTAJE

Usar o item H somente quando não for instalado a fita de LED.

Use item H only when the LED strip is not installed.

Use el elemento H solo cuando la tira de LED no esté instalada.

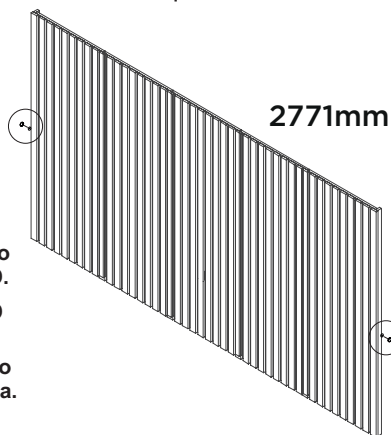

2771mm

H

x02

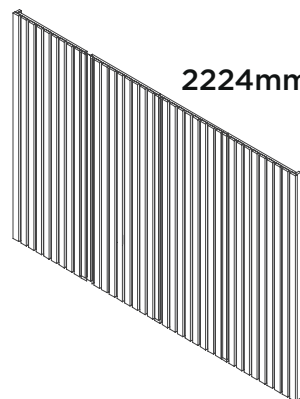

2224mm

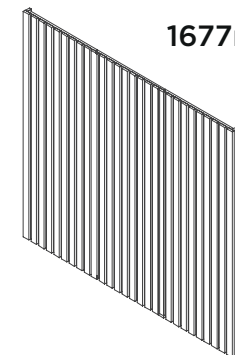

1677mm

