

# Instruções de montagem

Assembly Instructions / Instrucciones de Montaje

  
DELMARCO



**IS 0030**

# Instruções de montagem

Assembly Instructions / Instrucciones de Montaje

  
DELMARCO

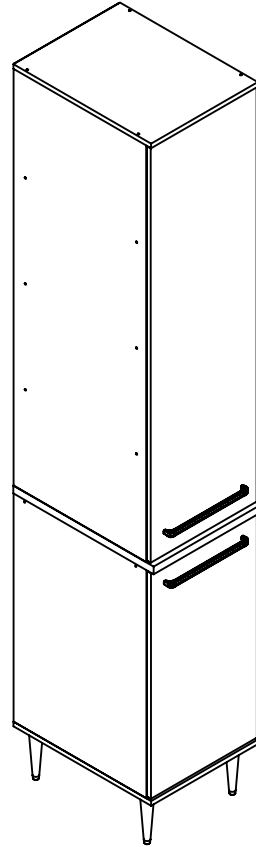

**IS 1840**

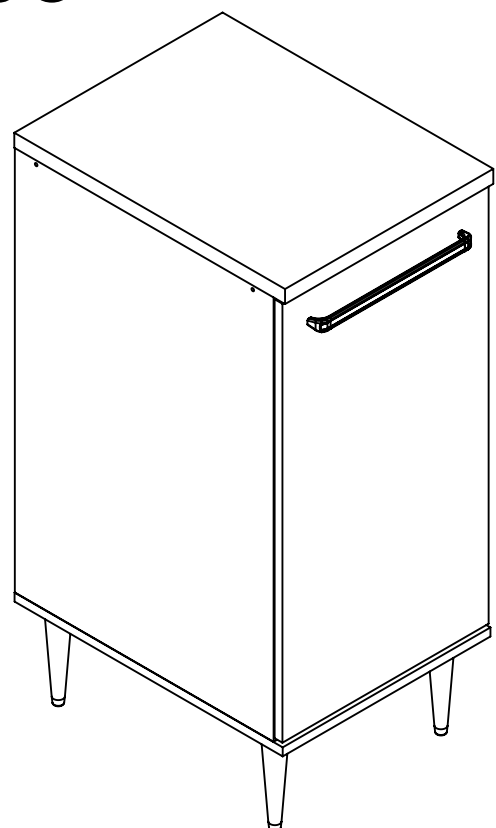

**Lista de ferragens  
Hardware list  
Lista de materiales**

<b>A</b>		CAVILHA Ø6X30 CLAVIJA Ø6X30 WOOD DOWEL Ø6X30	<b>16</b>
<b>B</b>		PARAFUSO CC 3,5X14 TORNILLO CC 3,5X14 SCREW CC 3,5X14	<b>2</b>
<b>C</b>		PARAFUSO CC 3,5X40 TORNILLO CC 3,5X40 SCREW CC 3,5X40	<b>08</b>
<b>DB</b>		DOBRADIÇA BISAGRA HINGE	<b>02</b>
<b>F</b>		PARAFUSO CF 4,5X50 TORNILLO CF 4,5X50 SCREW CF 4,5X50	<b>05</b>
<b>U</b>		ADESIVO TAPA FURO ADHESIVO STICKER	<b>04</b>
<b>G</b>		PROTEÇÃO SUP CANTONEIRA PROTECCIÓN ANGLE BRACKET	<b>01</b>
<b>H</b>		SUPORTE FIXAÇÃO SOPORTE DE FIJACIÓN FIXING SUPPORT	<b>01</b>
<b>I</b>		BUCHA PLÁSTICA CASQUILLO BUSHING	<b>01</b>
<b>M</b>		PREGO 10X10 CLAVO 10X10 NAIL	<b>25</b>
<b>Z</b>		PARAFUSO CF 3,5X25 TORNILLO CF 3,5X25 SCREW CF 3,5X25	<b>09</b>
<b>V</b>		COLA PEGAMENTO GLUE	<b>01</b>
<b>PX</b>		PUXADOR TIRADOR HANDLE	<b>01</b>
<b>PE</b>		PÉ PIE FOOT	<b>04</b>

**Lista de peças / Parts lists / Lista de piezas**

REF	DESC	COMP	LARG	ESP	QTD.
IS1503-01	LATERAL DIREITA/LADO DERECHO/RIGHT SIDE	740	497	15	1
IS1503-02	LATERAL ESQUERDA/LADO IZQUIERDO/LEFT SIDE	740	497	15	1
IS1503-03	BASE/BASE/BASE	399	515	15	1
IS1503-04	PRATELEIRA/ESTANTE/SHELF	368	350	15	1
IS1503-06	TRAVESSA FRONTAL/TRAVESAN~I/LONG PLATE	368	60	15	1
IS1503-10	TAMPO/TAPA/TOP	400	520	25	1
IS1503-12	PORTA/PUERTA/DOOR	396	730	15	1
IS1503-26	TRAVESSA TRASERA/TRAVESAN~I/LONG PLATE	368	60	15	1
IS1503-61	COSTA/FONDO/BACK	390	745	3	1

**FERRAMENTAS NECESSÁRIAS:  
HERRAMIENTAS NECESARIAS:  
NECESSARY TOOLS:**



**"IMPORTANTE LER COM ATENÇÃO  
E GUARDAR PARA EVENTUAIS  
CONSULTAS".**

**"IMPORTANTE LEER CON ATENCIÓN Y GUARDAR PARA  
EVENTUALES CONSULTAS".**

**"IMPORTANT TO READ CAREFULLY AND SAVE FOR ANY  
QUERIES".**

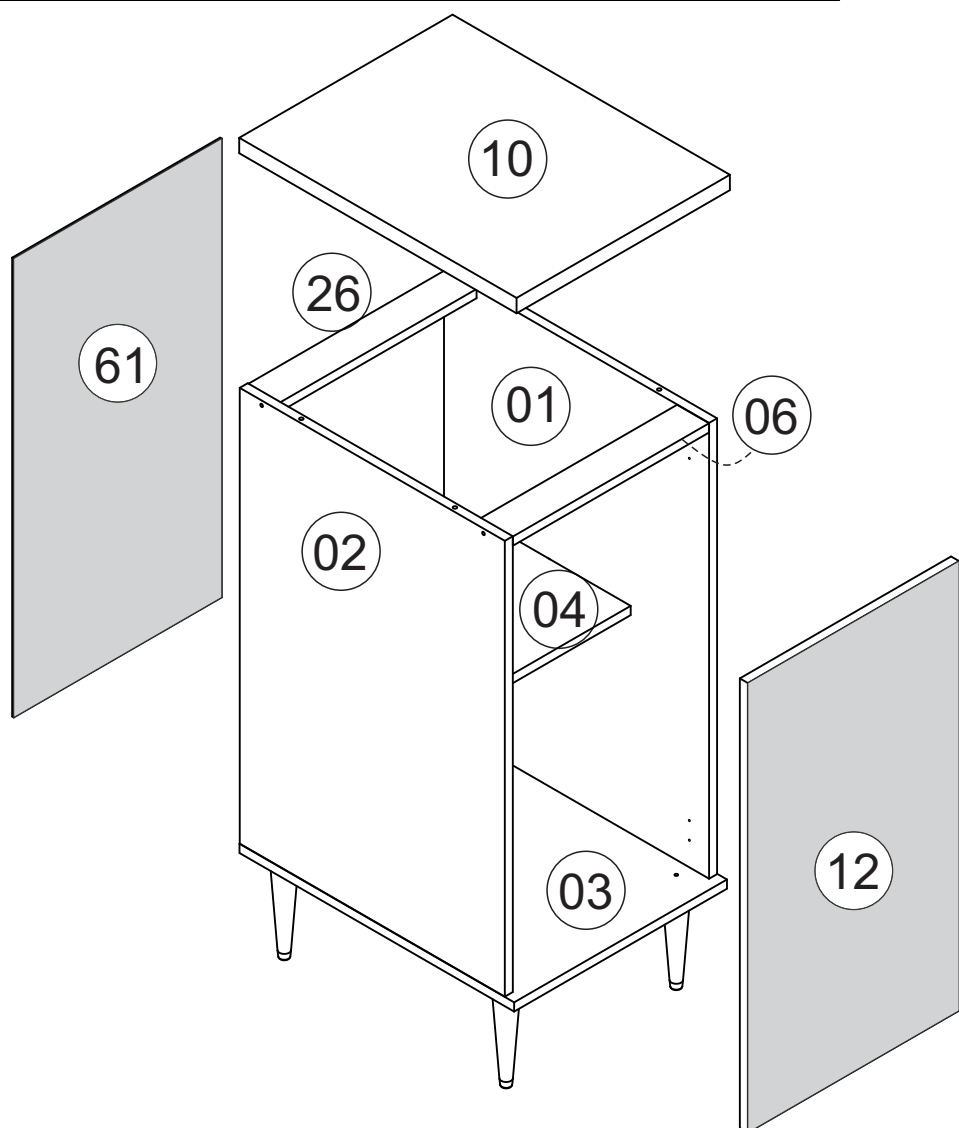

01

Fixar as cavilhas c/ cola  
Fije los pivotes con cola  
Attach the dowels with glue

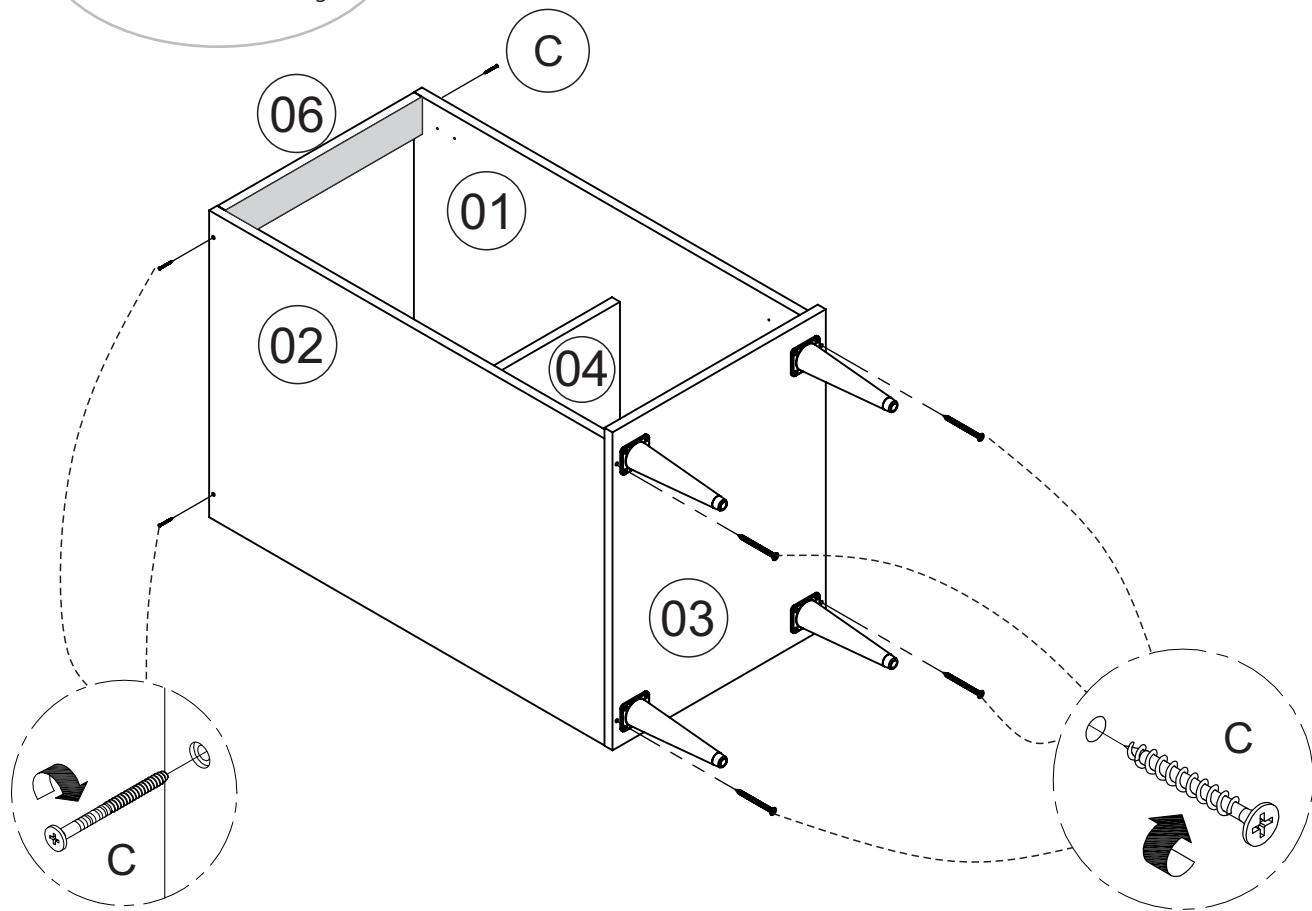

02

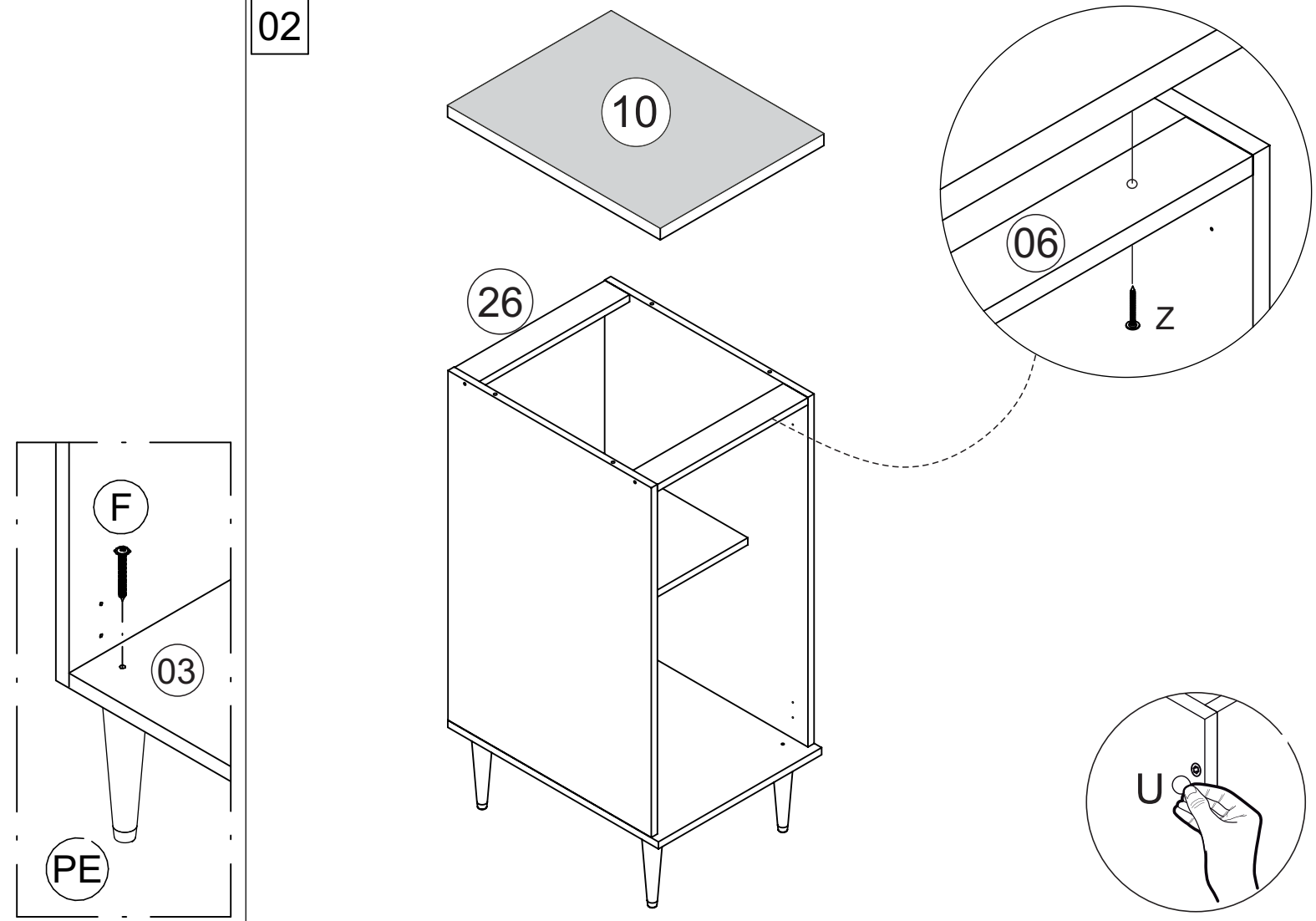

03

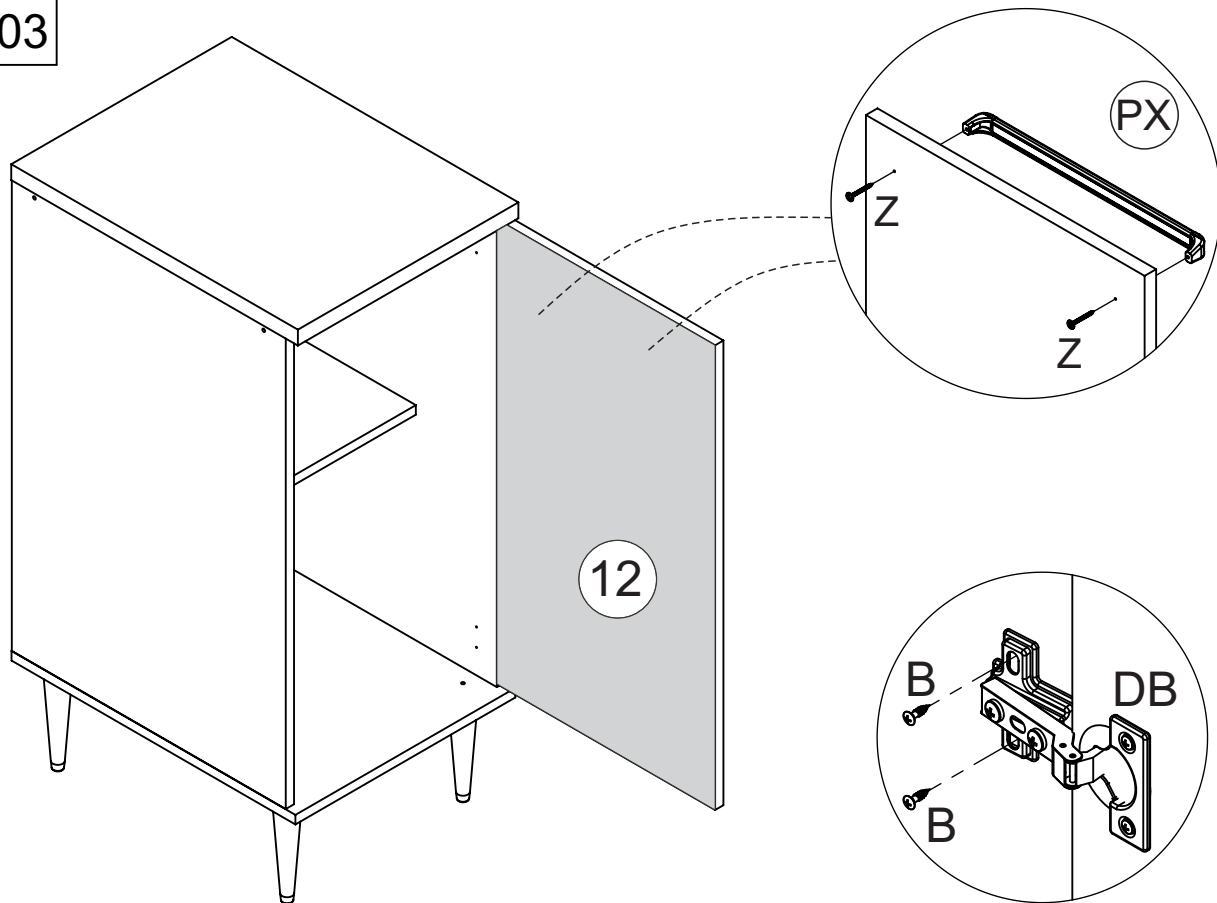

04

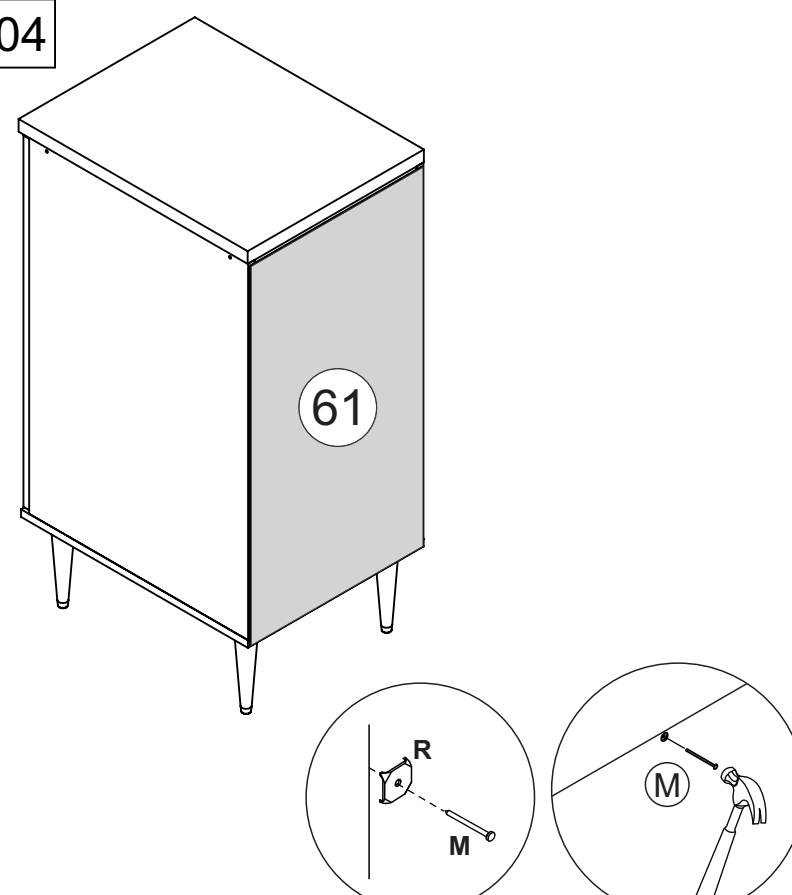

05

Parafuso "Z" união de módulos  
Tornillo "Z" unión de módulos

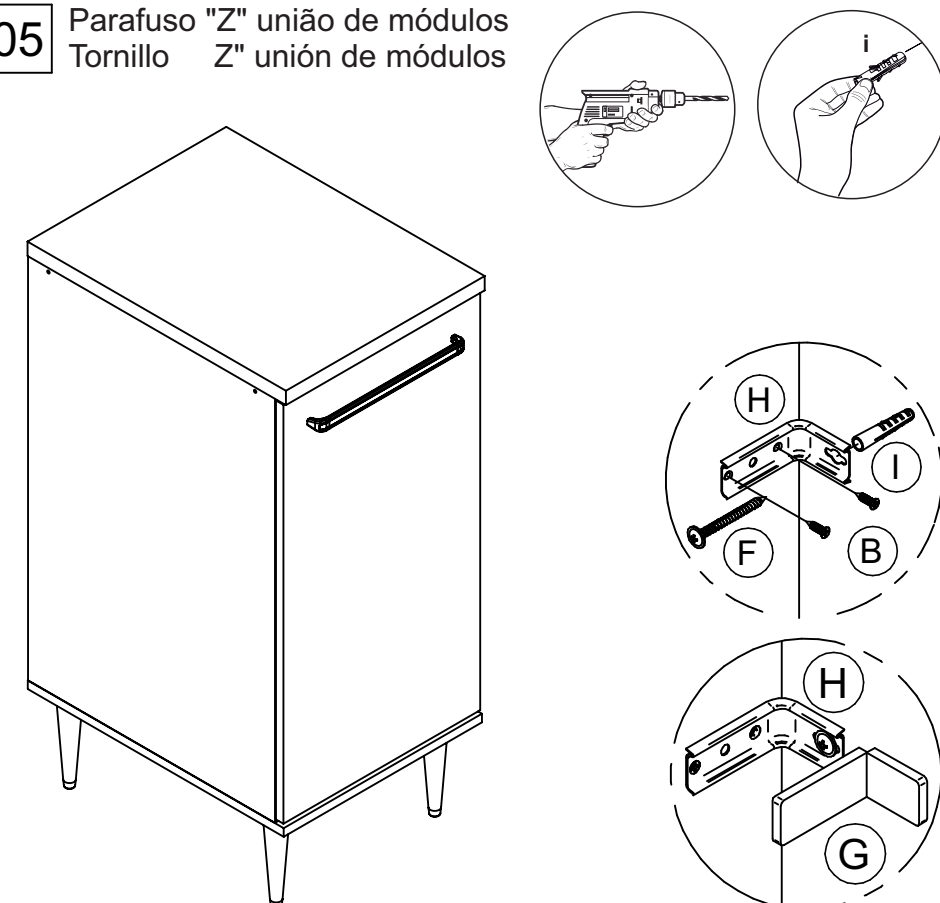



# IS 1703

## Instruções de montagem Assembly Instructions / Instrucciones de Montaje

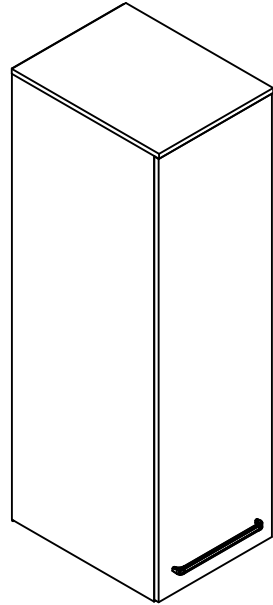

REF	DESC	COMP	LARG	ESP	QTD.
IS1703-01	LATERAL DIR/LADO DERECHO/RIGHT SIDE	1350	497	15	1
IS1703-02	LATERAL ESQ/LADO IZQUIERDO/LEFT SIDE	1350	497	15	1
IS1703-04	PRATELERA/ESTANTE/SHELF	368	497	15	3
IS1703-08	CHAPEU/SOMBRERO/HAT	400	515	15	1
IS1703-11	PORTA/PUERTA/DOOR	396	1342	15	1
IS1703-61	COSTA/COSTA/COAST	1370	390	3	1

<b>A</b>		CAVILHA Ø6X30 CLAVIJA Ø6X30 WOOD DOWEL Ø6X30	<b>20</b>
<b>B</b>		PARAFUSO CC 3,5X14 TORNILLO CC 3,5X14 SCREW CC 3,5X14	<b>02</b>
<b>C</b>		PARAFUSO CC 3,5X40 TORNILLO CC 3,5X40 SCREW CC 3,5X40	<b>20</b>
<b>DB</b>		DOBRADIÇA BISAGRA HINGE	<b>03</b>
<b>F</b>		PARAFUSO CF 4,5X50 TORNILLO CF 4,5X50 SCREW CF 4,5X50	<b>01</b>
<b>M</b>		PREGO 10X10 CLAVO 10X10 NAIL	<b>30</b>
<b>Z</b>		PARAFUSO CF 3,5X25 TORNILLO CF 3,5 X 25 SCREW CF 3,5X25	<b>05</b>
<b>U</b>		ADESIVO TAPA FURO ADHESIVO STICKER	<b>10</b>
<b>V</b>		COLA PEGAMENTO GLUE	<b>01</b>
<b>PX</b>		PUXADOR TIRADOR HANDLE	<b>01</b>

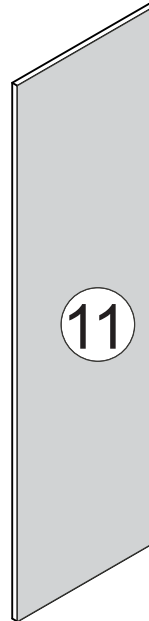
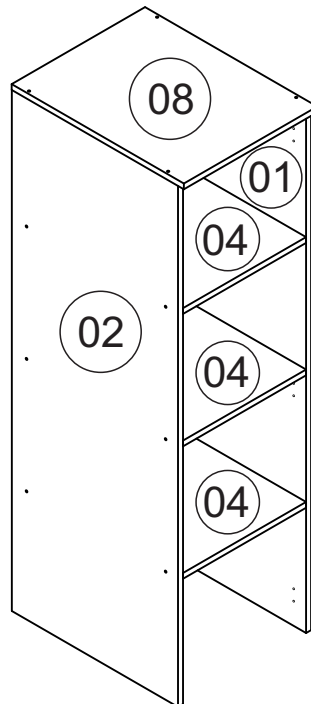
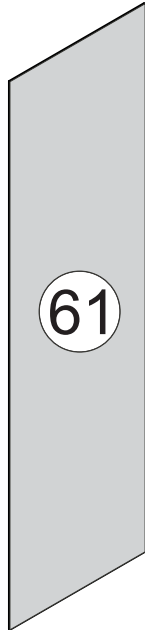

**"IMPORTANTE LER COM ATENÇÃO E GUARDAR PARA EVENTUAIS CONSULTAS".**

<b>G</b>		SUPORE FIXAÇÃO SOPORTE DE FIJACIÓN FIXING SUPPORT	<b>01</b>
<b>H</b>		PROTEÇÃO SUP CANTONEIRA PROTECCIÓN ANGLE BRACKET	<b>01</b>
<b>I</b>		BUCHA PLÁSTICA CASQUILLO BUSHING	<b>01</b>

# 1 IS 1703

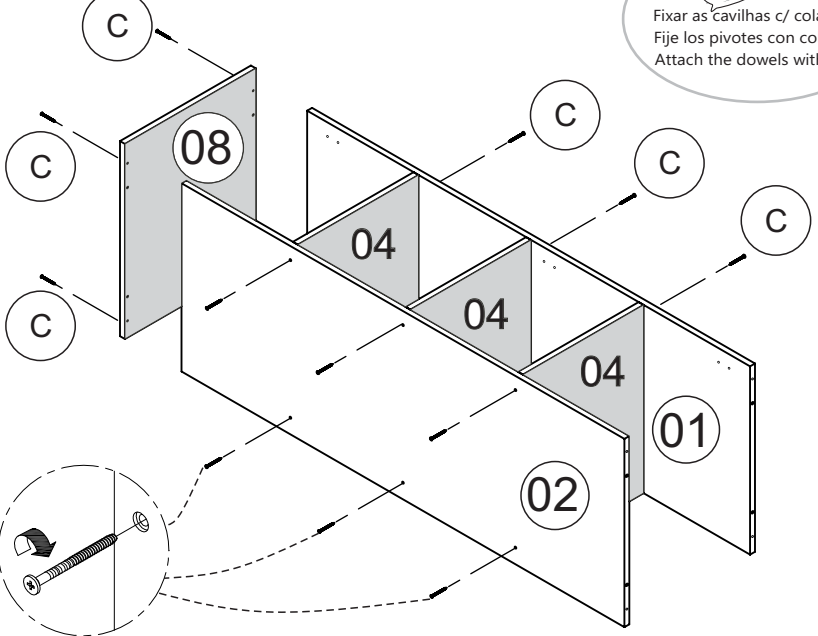

Fixar as cavilhas c/ cola  
Fije los pivotes con cola  
Attach the dowels with glue

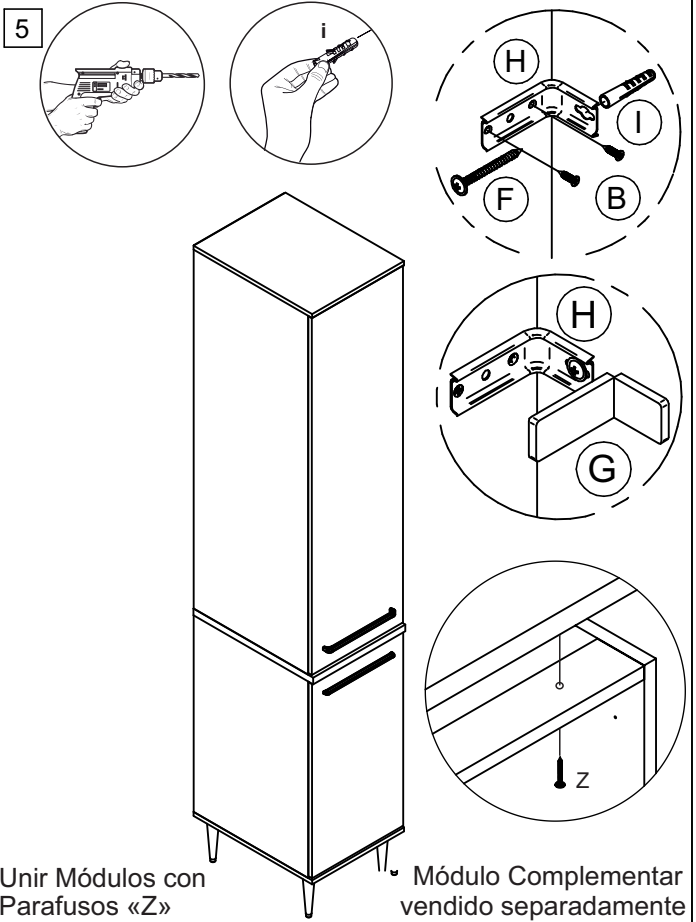
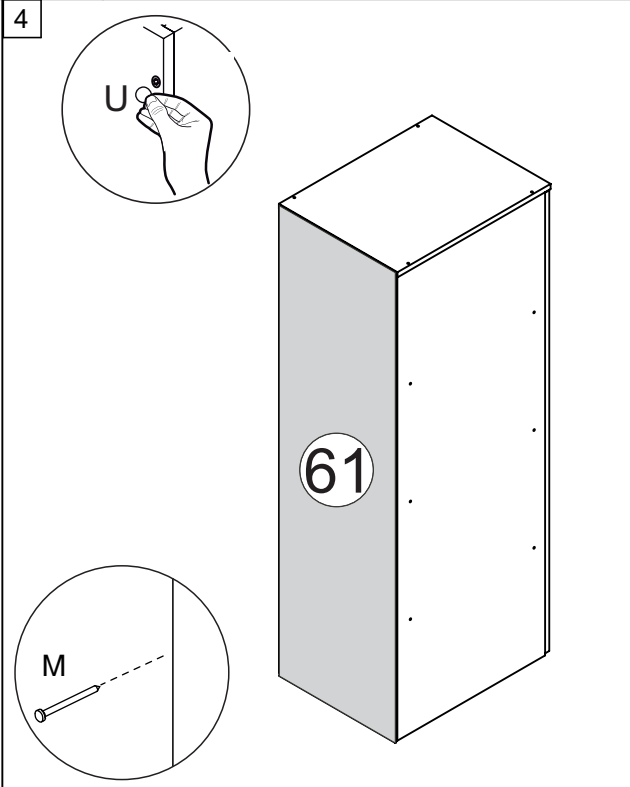
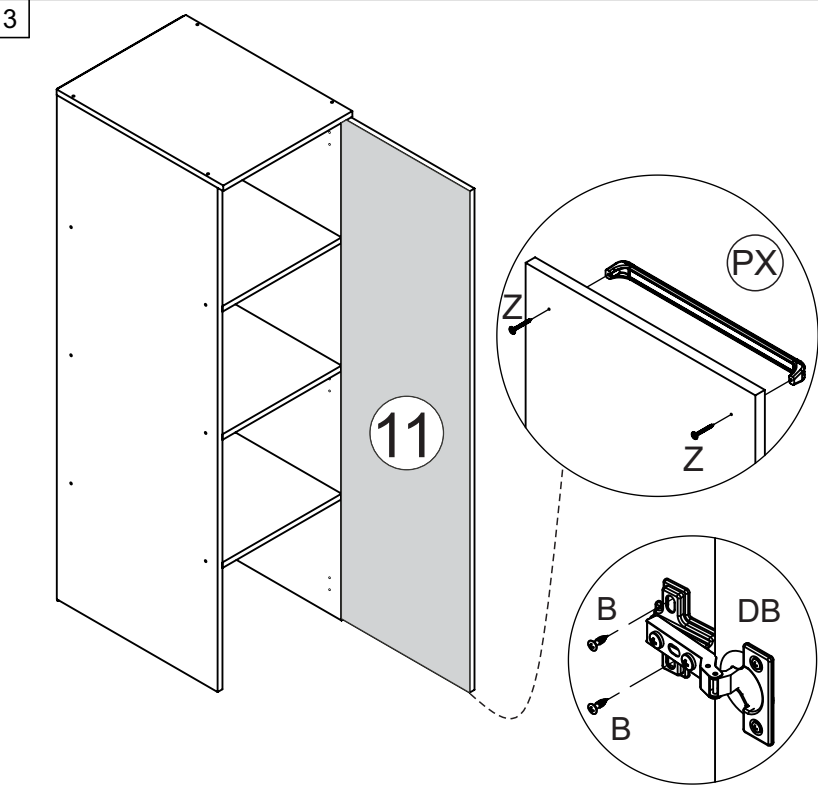
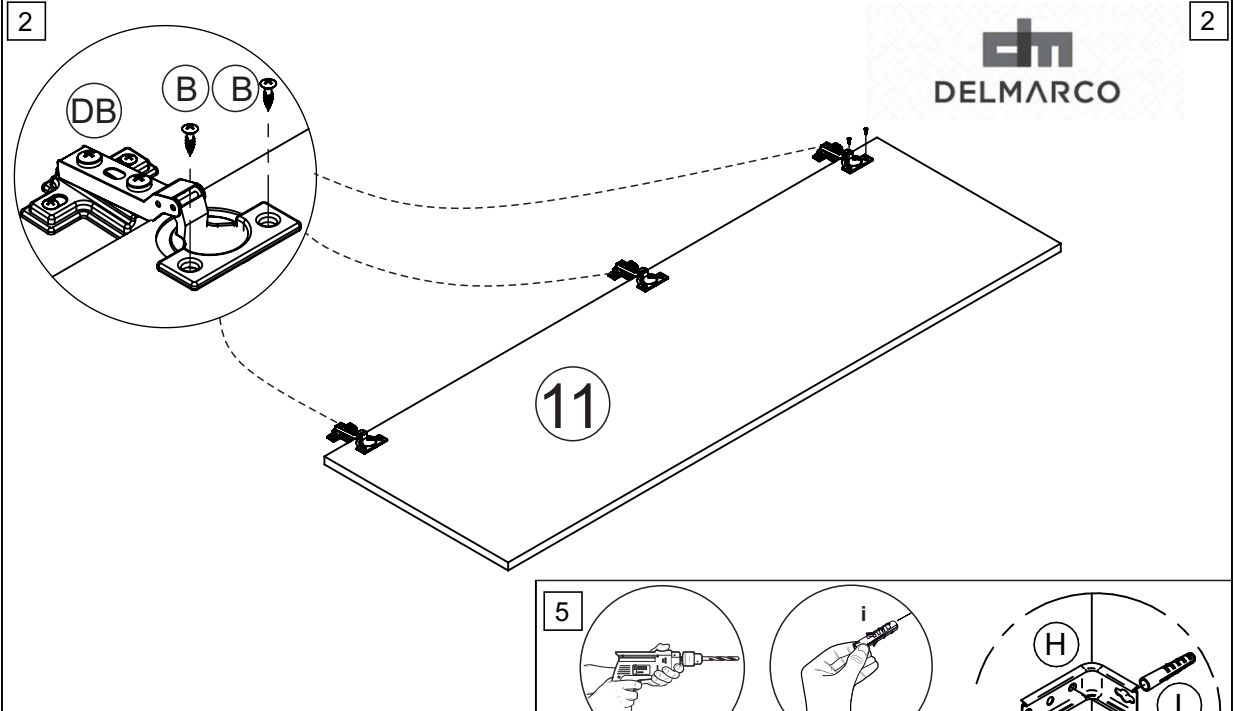

Unir Módulos con Parafusos «Z»  
Módulo Complementar vendido separadamente

# Instruções de montagem

Assembly Instructions / Instrucciones de Montaje

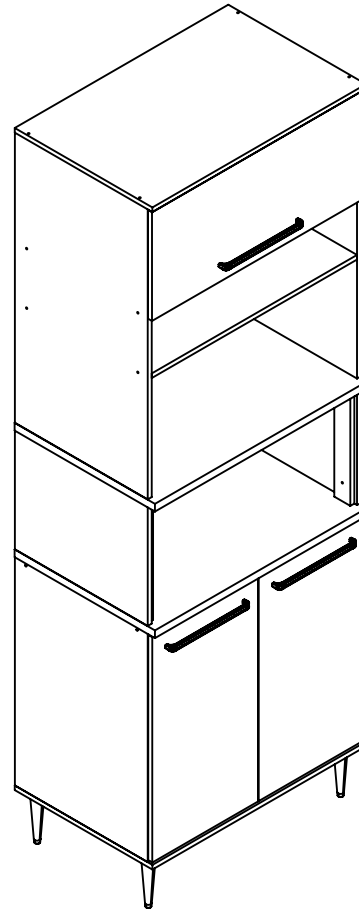

**IS 1802**

# IS 1702



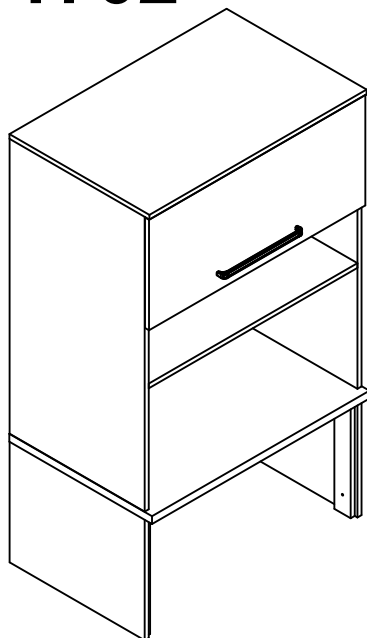



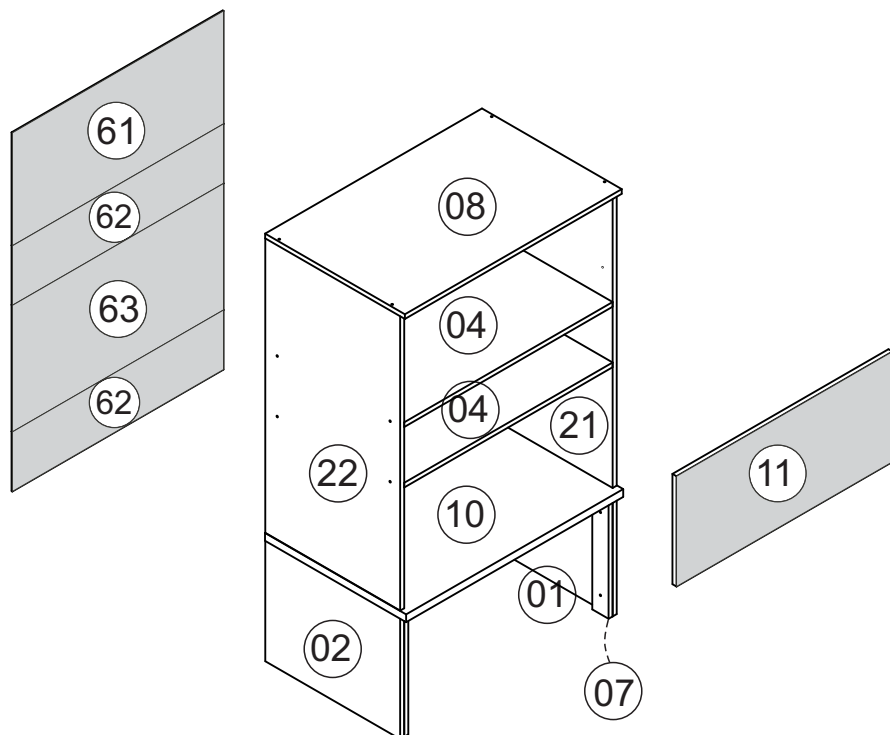





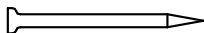

## Instruções de montagem Assembly Instructions / Instrucciones de Montaje



REF	DESC	COMP	LARG	ESP	QTD.
IS1702-01	LATERAL DIR/LADO DERECHO/RIGHT SIDE	385	497	15	1
IS1702-02	LATERAL ESQ/LADO IZQUIERDO/LEFT SIDE	385	497	15	1
IS1702-04	PRATELERA/ESTANTE/SHELF	768	497	15	1
IS1702-07	APOIO FORNO/SOPORTE HORNO/	385	60	15	1
IS1702-08	CHAPEU/SOMBRERO/HAT	800	515	15	1
IS1702-10	TAMPO/TAPA/TOP	800	520	25	1
IS1702-11	PORTA/PUERTA/DOOR	796	352	15	1
IS1702-21	LATERAL DIR/LADO DERECHO/RIGHT SIDE	940	497	15	1
IS1702-22	LATERAL ESQ/LADO IZQUIERDO/LEFT SIDE	940	497	15	1
IS1702-61	COSTA/COSTA/COAST	790	366	3	1
IS1702-62	COSTA/COSTA/COAST	790	193	3	2
IS1702-63	COSTA/COSTA/COAST	790	410	3	1

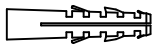

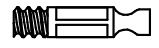

  
**"IMPORTANTE LER COM ATENÇÃO E GUARDAR PARA EVENTUAIS CONSULTAS".**

<b>A</b>		CAVILHA Ø6X30 CLAVIJA Ø6X30 WOOD DOWEL Ø6X30	<b>24</b>
<b>B</b>		PARAFUSO CC 3,5X14 TORNILLO CC 3,5X14 SCREW CC 3,5X14	<b>02</b>
<b>C</b>		PARAFUSO CC 3,5X40 TORNILLO CC 3,5X40 SCREW CC 3,5X40	<b>20</b>
<b>DB</b>		DOBRADEIRA BISAGRA HINGE	<b>02</b>
<b>F</b>		PARAFUSO CF 4,5X50 TORNILLO CF 4,5X50 SCREW CF 4,5X50	<b>01</b>
<b>M</b>		PREGO 10X10 CLAVO 10X10 NAIL	<b>55</b>
<b>Z</b>		PARAFUSO CF 3,5X25 TORNILLO CF 3,5 X 25 SCREW CF 3,5X25	<b>09</b>
<b>U</b>		ADESIVO TAPA FURO ADHESIVO STICKER	<b>06</b>
<b>V</b>		COLA PEGAMENTO GLUE	<b>01</b>
<b>PX</b>		PUXADOR TIRADOR HANDLE	<b>01</b>
<b>G</b>		SUPORE FIXAÇÃO SOPORTE DE FIJACIÓN FIXING SUPPORT	<b>01</b>
<b>H</b>		PROTEÇÃO SUP CANTONEIRA PROTECCIÓN ANGLE BRACKET	<b>01</b>
<b>I</b>		BUCHA PLÁSTICA CASQUILLO BUSHING	<b>01</b>
<b>X</b>		FIXADOR COSTA FIJADOR DE ESPALDA BACK FIXER	<b>12</b>
<b>J</b>		TAMBOR MINIFIX TAMBOR MINIFIX MINIFIX DRUM	<b>04</b>
<b>K</b>		PARAFUSO MINIFIX TORNILLO MINIFIXO MINIFIX SCREW	<b>04</b>
<b>P</b>		PISTAO PISTON PISTON	<b>01</b>

1

# IS 1702

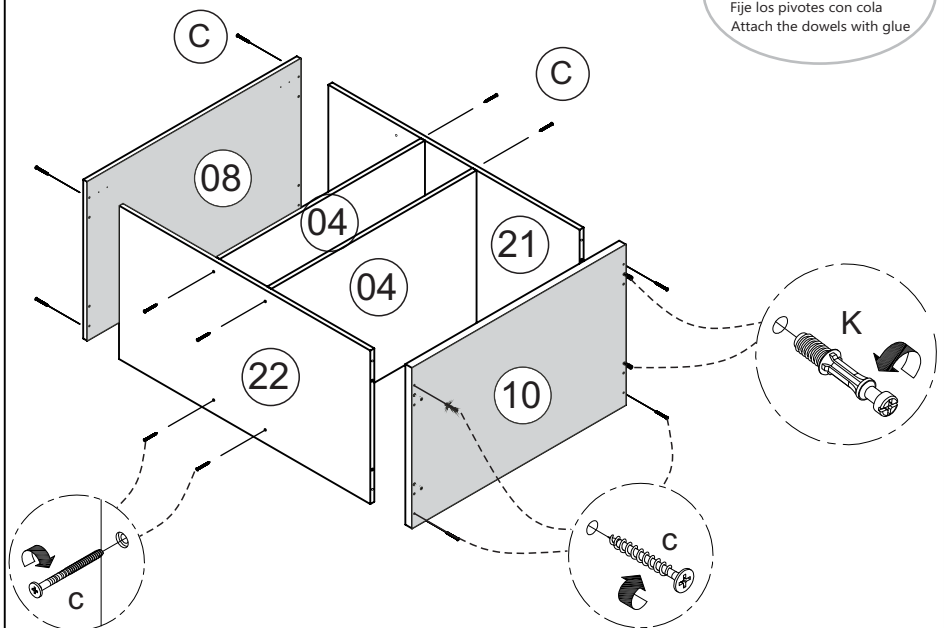
Fixar as cavilhas c/ cola  
 Fije los pivotes con cola  
 Attach the dowels with glue



2

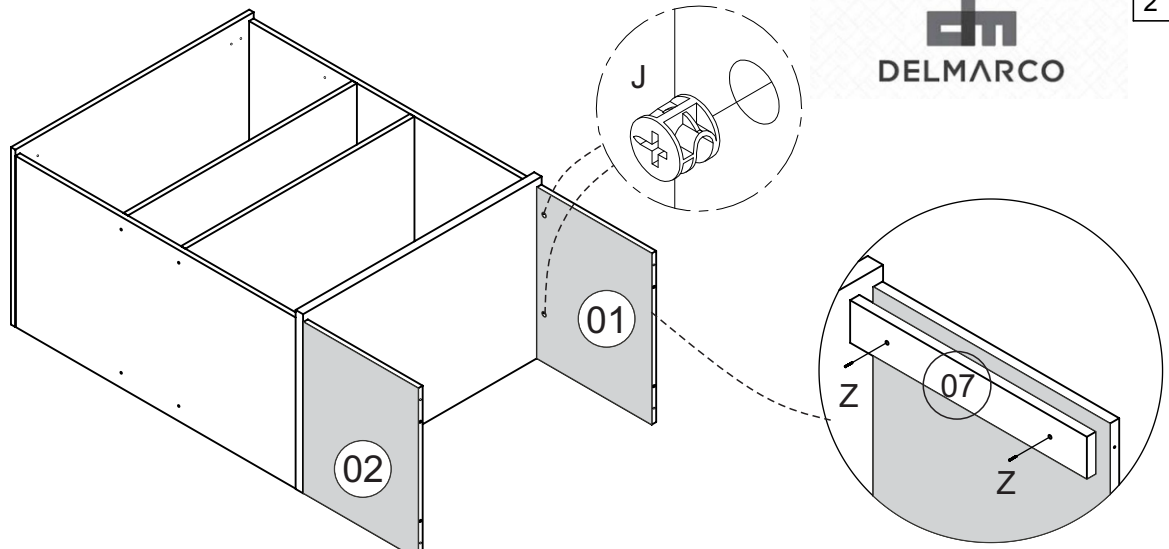

3

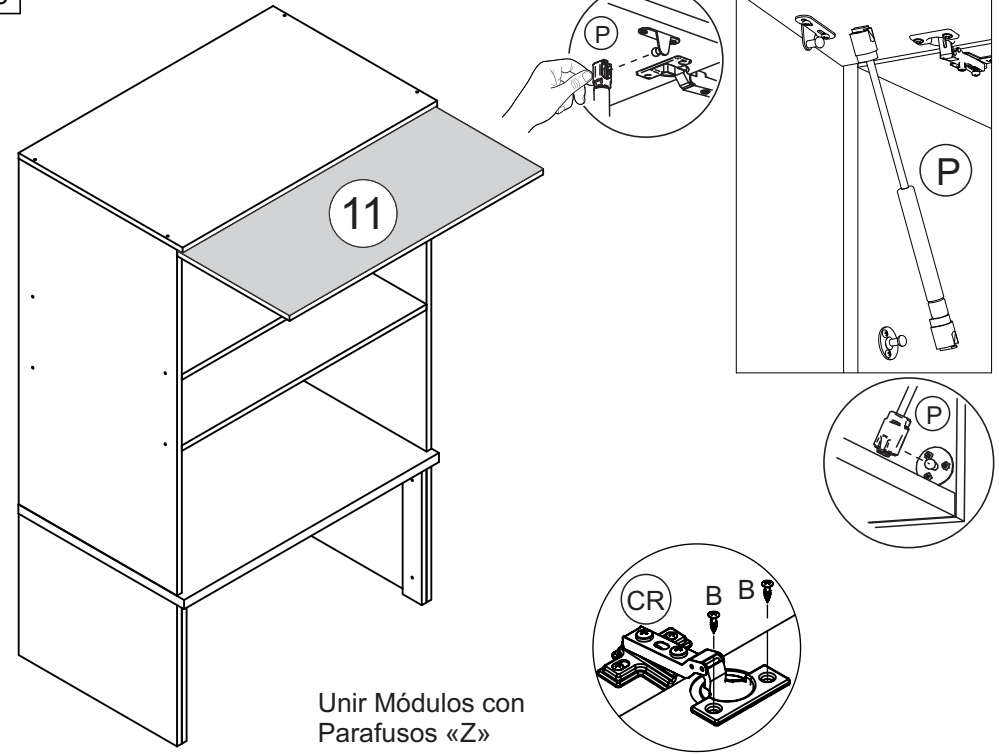

Unir Módulos con  
 Parafusos «Z»

4

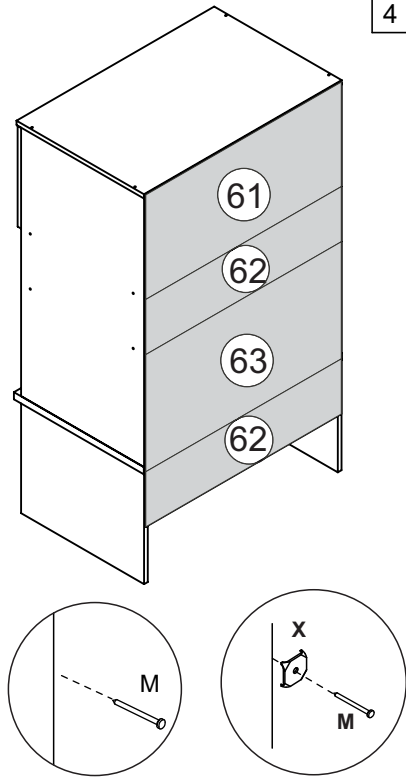

5

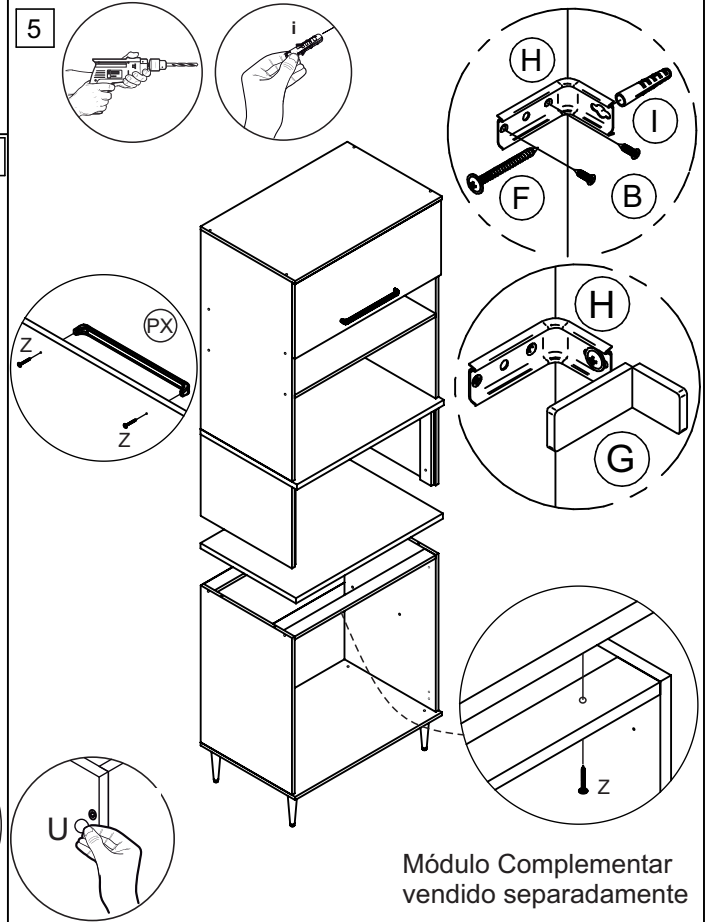

Módulo Complementar  
 vendido separadamente



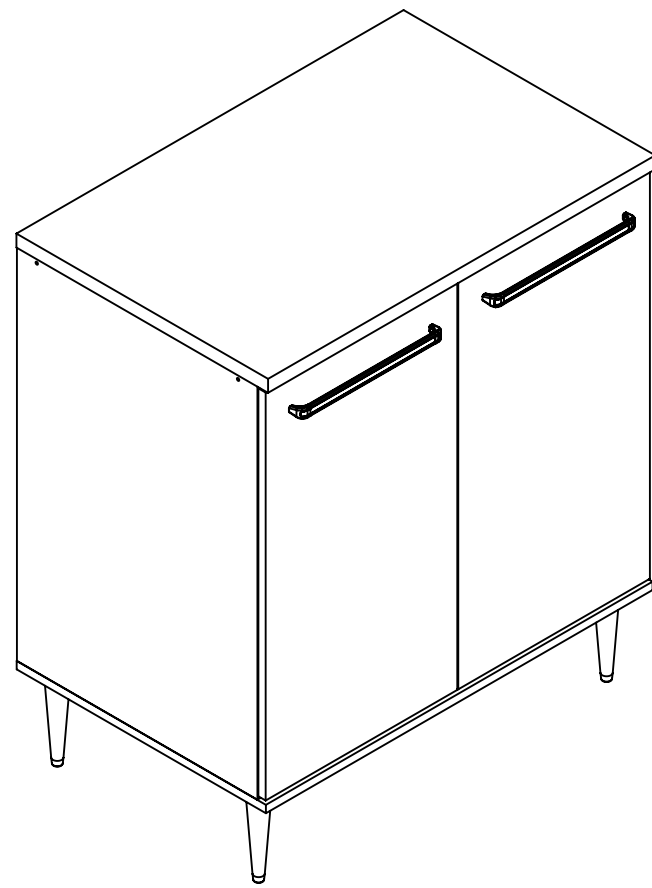

**Lista de ferragens  
Hardware list  
Lista de materiales**

<b>A</b>		CAVILHA Ø6X30 CLAVIJA Ø6X30 WOOD DOWEL Ø6X30	<b>16</b>
<b>B</b>		PARAFUSO CC 3,5X14 TORNILLO CC 3,5X14 SCREW CC 3,5X14	<b>02</b>
<b>C</b>		PARAFUSO CC 3,5X40 TORNILLO CC 3,5X40 SCREW CC 3,5X40	<b>08</b>
<b>DB</b>		DOBRADIÇA BISAGRA HINGE	<b>04</b>
<b>F</b>		PARAFUSO CF 4,5X50 TORNILLO CF 4,5X50 SCREW CF 4,5X50	<b>05</b>
<b>Z</b>		PARAFUSO CF 3,5X25 TORNILLO CF 3,5X25 SCREW CF 3,5X25	<b>11</b>
<b>U</b>		ADESIVO TAPA FURO ADHESIVO STICKER	<b>04</b>
<b>G</b>		PROTEÇÃO SUP CANTONEIRA PROTECCIÓN ANGLE BRACKET	<b>01</b>
<b>H</b>		SUPORTE FIXAÇÃO SOPORTE DE FIJACIÓN FIXING SUPPORT	<b>01</b>
<b>I</b>		BUCHA PLÁSTICA CASQUILLO BUSHING	<b>01</b>
<b>M</b>		PREGO 10X10 CLAVO 10X10 NAIL	<b>45</b>
<b>V</b>		COLA PEGAMENTO GLUE	<b>01</b>
<b>PX</b>		PUXADOR TIRADOR HANDLE	<b>02</b>
<b>PE</b>		PÉ PIE FOOT	<b>04</b>
<b>X</b>		FIXADOR COSTA FIJADOR DE ESPALDA BACK FIXER	<b>05</b>

**Lista de peças / Parts lists / Lista de piezas**

REF	DESC	COMP	LARG	ESP	QTD.
IS1501-01	LATERAL DIREITA/LADO DERECHO/RIGHT SIDE	740	497	15	1
IS1501-02	LATERAL ESQUERDA/LADO IZQUIERDO/LEFT SIDE	740	497	15	1
IS1501-03	BASE/BASE/BASE	799	515	15	1
IS1501-04	PRATELEIRA/ESTANTE/SHELF	768	350	15	1
IS1501-06	TRAVESSA FRONTAL/TRAVESAN~I/LONG PLATE	768	60	15	1
IS1501-10	TAMPO/TAPA/TOP	800	520	25	1
IS1501-12	PORTA/PUERTA/DOOR	396	730	15	2
IS1501-26	TRAVESSA TRASERA/TRAVESAN~I/LONG PLATE	768	60	15	1
IS1501-61	COSTA/FONDO/BACK	375	790	3	2

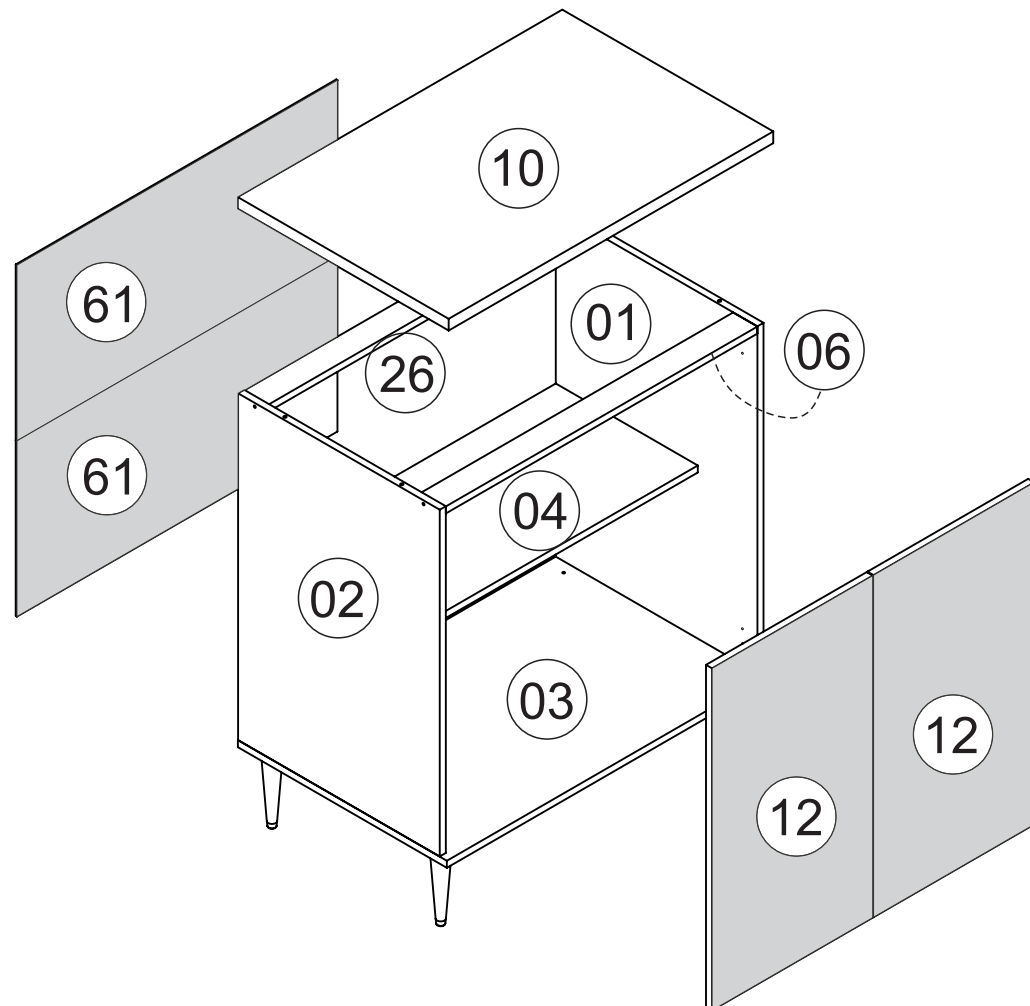

FERRAMENTAS NECESSÁRIAS:  
HERRAMIENTAS NECESARIAS:  
NECESSARY TOOLS:



**"IMPORTANTE LER COM ATENÇÃO  
E GUARDAR PARA EVENTUAIS  
CONSULTAS".**

"IMPORTANTE LEER CON ATENCIÓN Y GUARDAR PARA  
EVENTUALES CONSULTAS".

"IMPORTANT TO READ CAREFULLY AND SAVE FOR ANY  
QUERIES".

01

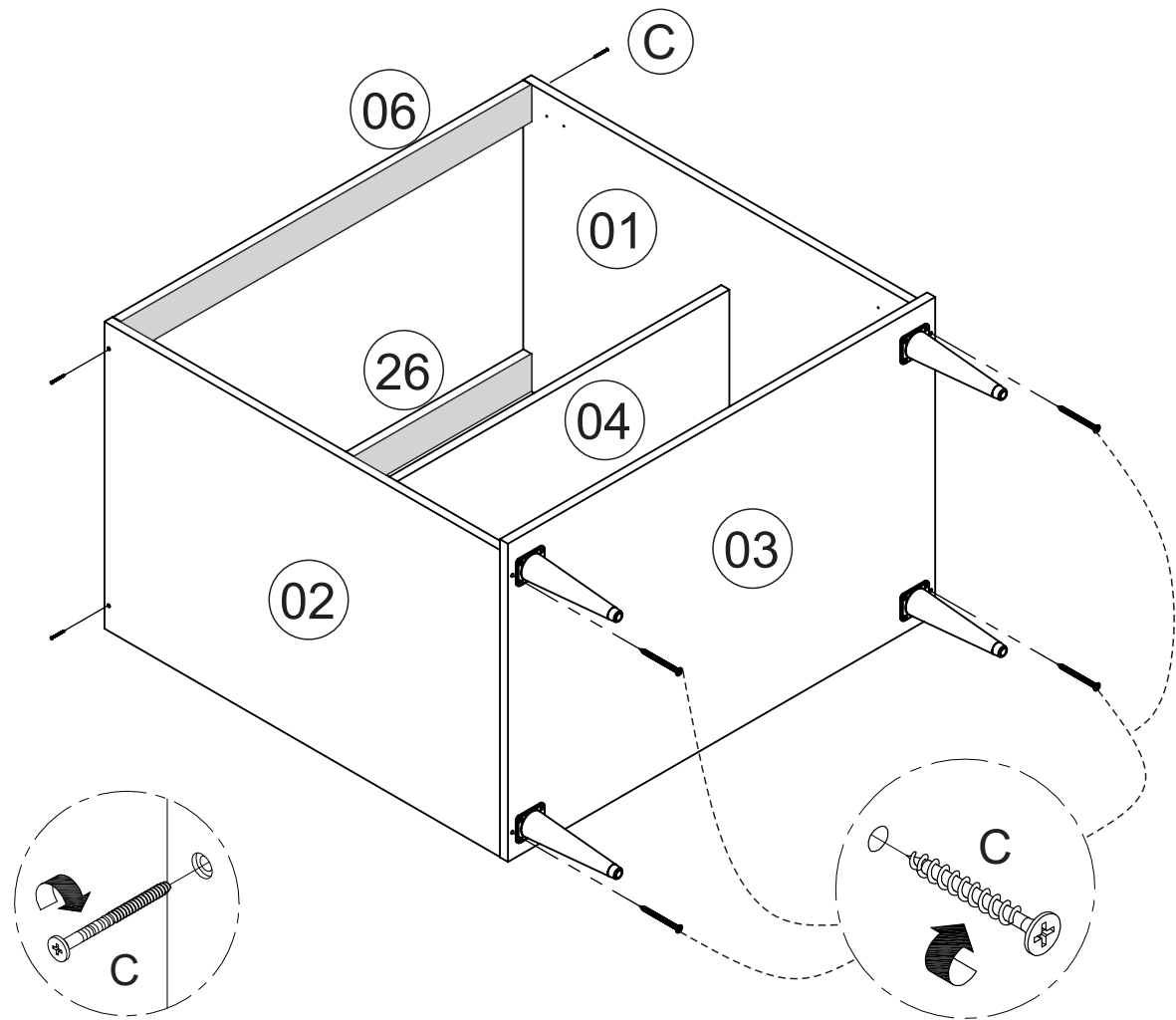

Fixar as cavilhas c/ cola  
Fije los pivotes con cola  
Attach the dowels with glue

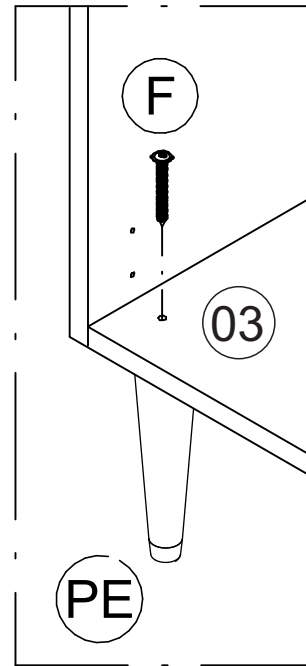

02

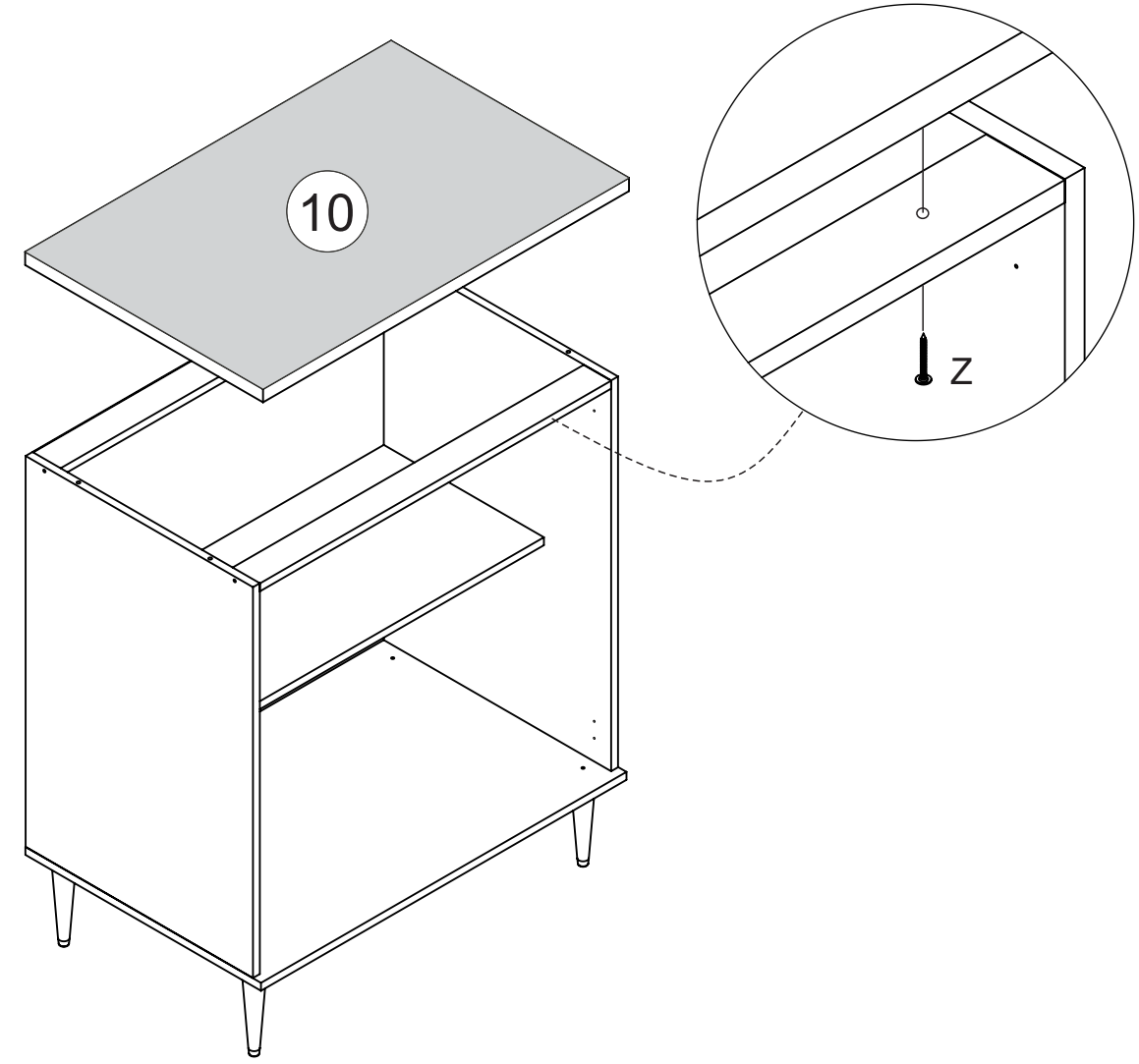

03

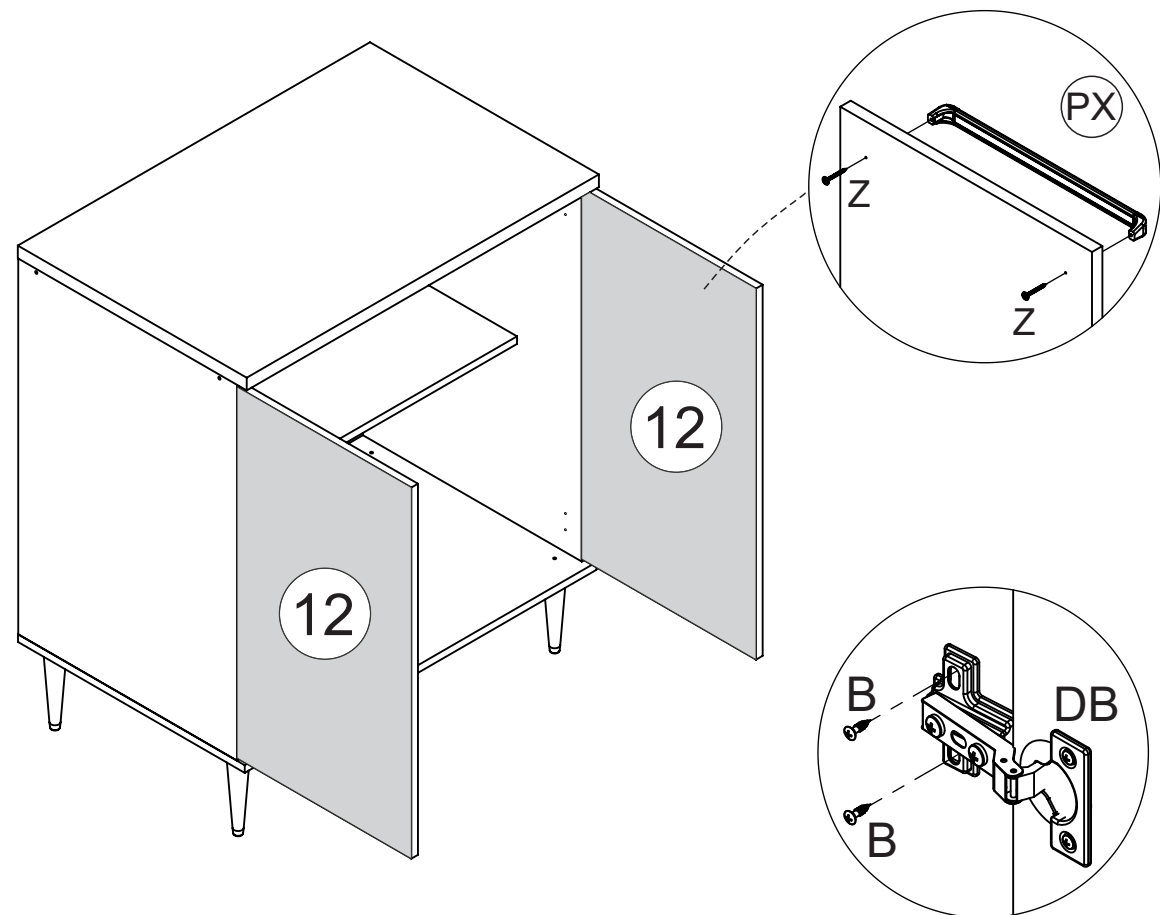

04

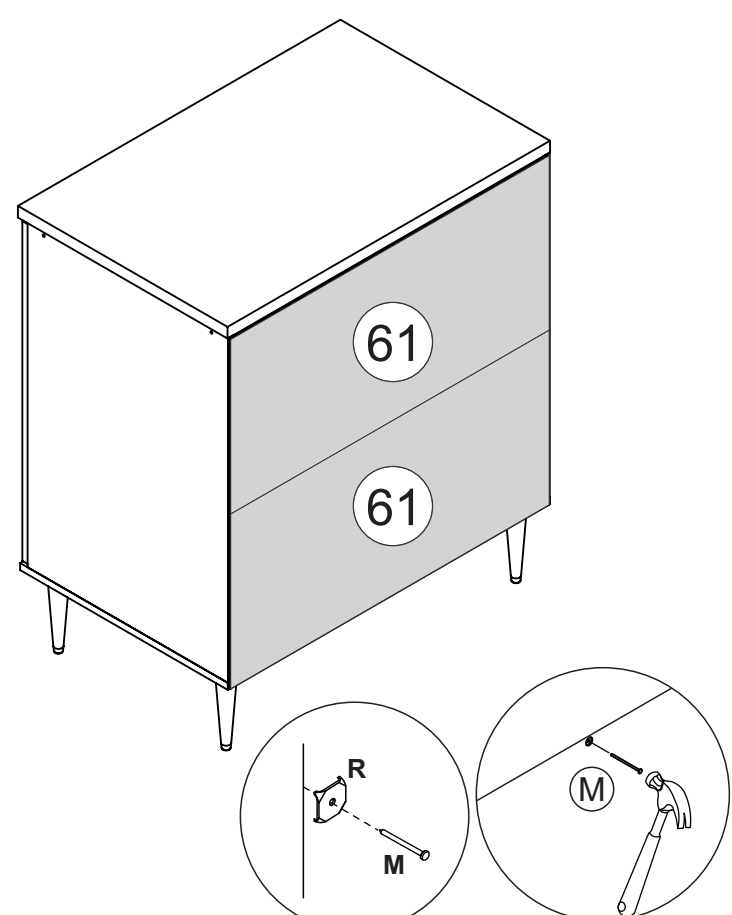

05

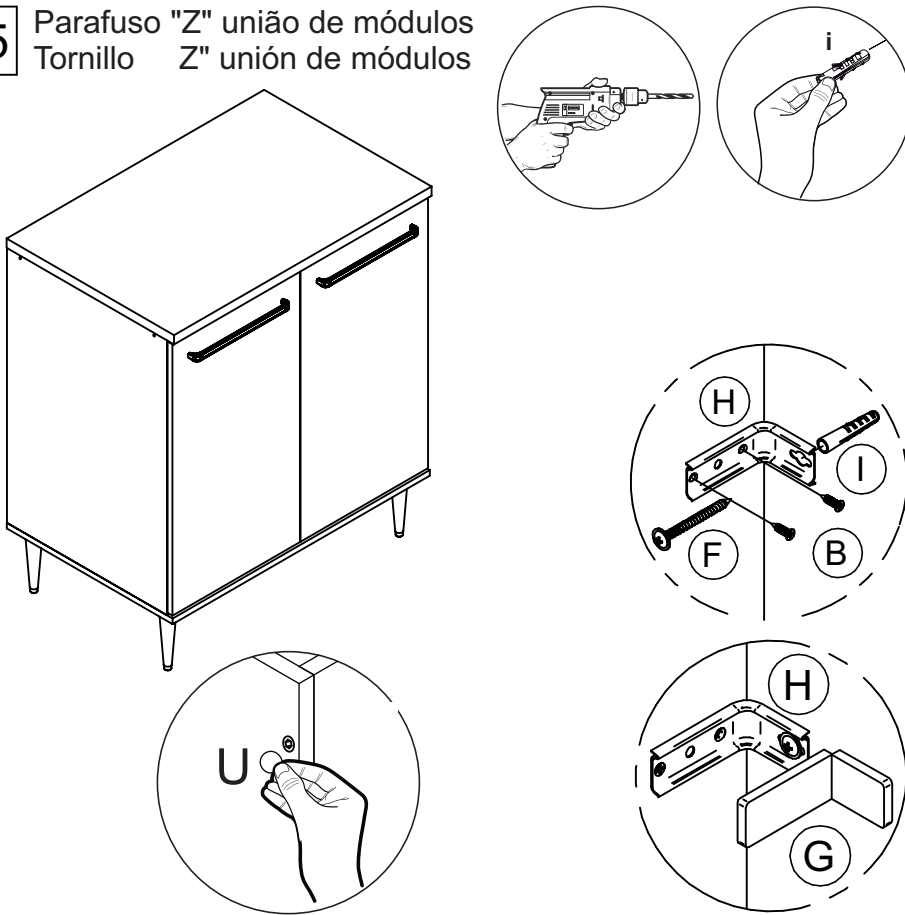

# Instruções de montagem

Assembly Instructions / Instrucciones de Montaje

  
DELMARCO

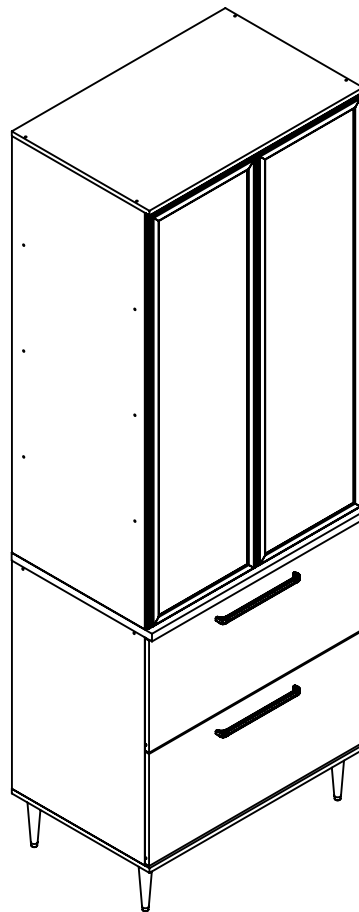

**IS 1852**

# IS 1704

## Instruções de montagem / Assembly Instructions / Instrucciones de Montaje

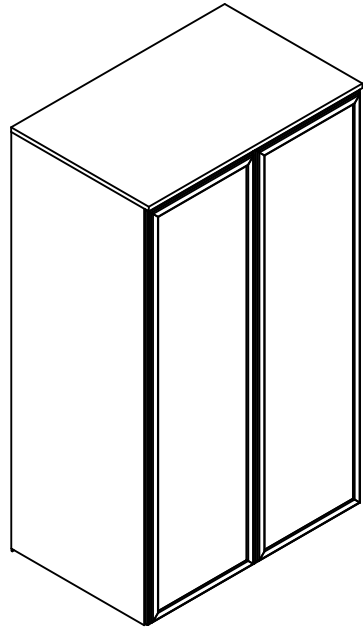

REF	DESC	COMP	LARG	ESP	QTD.
IS1704-01	LATERAL DIR/LADO DERECHO/RIGHT SIDE	1350	497	15	1
IS1704-02	LATERAL ESQ/LADO IZQUIERDO/LEFT SIDE	1350	497	15	1
IS1704-04	PRATELERA/ESTANTE/SHELF	768	497	15	2
IS1704-08	CHAPEU/SOMBREIRO/HAT	800	515	15	1
IS1704-11	PORTA/PUERTA/DOOR	396	1342	15	2
IS1704-24	PRATELERA/ESTANTE/SHELF	768	495	15	1
IS1704-61	COSTA/COSTA/COAST	790	343	3	4

<b>A</b>		CAVILHA Ø6X30 CLAVIJA Ø6X30 WOOD DOWEL Ø6X30	<b>20</b>
<b>B</b>		PARAFUSO CC 3,5X14 TORNILLO CC 3,5X14 SCREW CC 3,5X14	<b>02</b>
<b>C</b>		PARAFUSO CC 3,5X40 TORNILLO CC 3,5X40 SCREW CC 3,5X40	<b>20</b>
<b>DB</b>		DOBRADIÇA BISAGRA HINGE	<b>06</b>
<b>F</b>		PARAFUSO CF 4,5X50 TORNILLO CF 4,5X50 SCREW CF 4,5X50	<b>01</b>
<b>M</b>		PREGO 10X10 CLAVO 10X10 NAIL 10X10	<b>60</b>
<b>Z</b>		PARAFUSO CF 3,5X25 TORNILLO CF 3,5 X 25 SCREW CF 3,5X25	<b>04</b>
<b>U</b>		ADESIVO TAPA FURO ADHESIVO STICKER	<b>10</b>
<b>V</b>		COLA PEGAMENTO GLUE	<b>01</b>
<b>X</b>		FIXADOR COSTAS FIJADOR PRARA FONDO BACK SUPPORT	<b>12</b>
<b>Y</b>		PULSADOR LEGUMBRES PULSE	<b>02</b>
<b>Y1</b>		PULSADOR LEGUMBRES PULSE	<b>02</b>
<b>Y2</b>		BATENTE SOLAPA FLAP	<b>02</b>

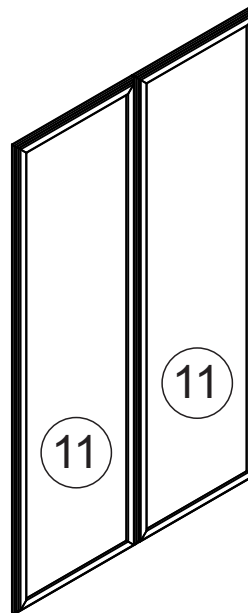
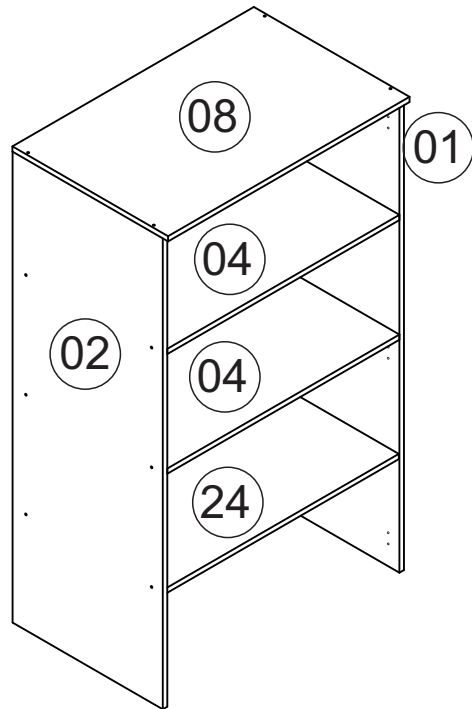
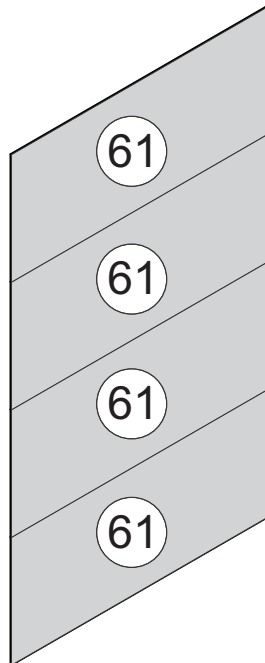

**"IMPORTANTE LER COM ATENÇÃO E GUARDAR PARA EVENTUAIS CONSULTAS".**

<b>G</b>		SUPORE FIXAÇÃO SOPORTE DE FIJACIÓN FIXING SUPPORT	<b>01</b>
<b>H</b>		PROTEÇÃO SUP CANTONEIRA PROTECCIÓN ANGLE BRACKET	<b>01</b>
<b>I</b>		BUCHA PLÁSTICA CASQUILLO BUSHING	<b>01</b>

**1** **IS 1704**

Fixar as cavilhas c/ cola  
Fije los pivotes con cola  
Attach the dowels with glue

**2**

**delmarco**

370 mm

370 mm

370 mm

**3**

310 mm

310 mm

**4**

61

61

61

61

X

M

M

**5**

Unir Módulos con Parafusos «Z»

Módulo Complementar vendido separadamente





### Lista de ferragens

### Lista de materiales Hardware list

<b>A</b>		CAVILHA Ø6X30 CLAVIJA Ø6X30 WOOD DOWEL Ø6X30	<b>30</b>
<b>B</b>		PARAFUSO CC 3,5X14 TORNILLO CC 3,5X14 SCREW CC 3,5X14	<b>26</b>
<b>C</b>		PARAFUSO CC 3,5X40 TORNILLO CC 3,5X40 SCREW CC 3,5X40	<b>14</b>
<b>F</b>		PARAFUSO CF 4,5X50 TORNILLO CF 4,5X50 SCREW CF 4,5X50	<b>05</b>
<b>M</b>		PREGO 10X10 CLAVO 10X10 NAIL	<b>75</b>
<b>Z</b>		PARAFUSO CF 3,5X25 TORNILLO CF 3,5 X 25 SCREW CF 3,5X25	<b>11</b>
<b>U</b>		ADESIVO TAPA FURO STICKER	<b>04</b>
<b>V</b>		COLA PEGAMENTO GLUE	<b>01</b>
<b>PE</b>		PÉ PIE FOOT	<b>04</b>
<b>PX</b>		PUXADOR TIRADOR HANDLE	<b>02</b>
<b>G</b>		SUPORE FIXAÇÃO SOPORTE DE FIJACIÓN FIXING SUPPORT	<b>01</b>
<b>H</b>		PROTEÇÃO SUP CANTONEIRA PROTECCIÓN ANGLE BRACKET	<b>01</b>
<b>I</b>		BUCHA PLÁSTICA CASQUILLO BUSHING	<b>01</b>
<b>H</b>		PERFIL PERFIL PROFILE	<b>01</b>
<b>CR</b>		CORREDIÇA 350 CORREDERA SLIDE	<b>02</b>

### Lista de peças / Parts lists / Lista de piezas

REF	DESC	COMP	LARG	ESP	QTD.
IS1511-01	LATERAL DIREITA/LADO DERECHO/RIGHT SIDE	740	497	15	1
IS1511-02	LATERAL ESQUERDA/LADO IZQUIERDO/LEFT SIDE	740	497	15	1
IS1511-03	BASE/BASE/BASE	799	515	15	1
IS1511-06	TRAVESSA FRONTAL/TRAVESAN~I/LONG PLATE	768	60	15	1
IS1511-09	APOIO/SOPORTE/SHELF	380	60	15	2
IS1511-10	TAMPO/TAPA/TOP	800	520	25	1
IS1511-15	LATERAL GAVETA DIR/CAJÓN LATERAL/SIDE DRAWER	380	195	15	2
IS1511-16	LATERAL GAVETA ESQ/CAJÓN LATERAL/SIDE DRAWER	380	195	15	2
IS1511-18	COST GAVETA ESQ/CAJÓN COSTADO/SIDE DRAWER	714	195	15	2
IS1511-20	FRENTE GAVETA/FRENTE DE CAJÓN/DRAWER FRONT	796	363	15	2
IS1511-26	TRAVESSA TRASERA/TRAVESAN~I/LONG PLATE	768	60	15	1
IS1511-60	COSTA/FONDO/BACK	383	742	3	2
IS1511-61	COSTA/FONDO/BACK	375	790	3	2

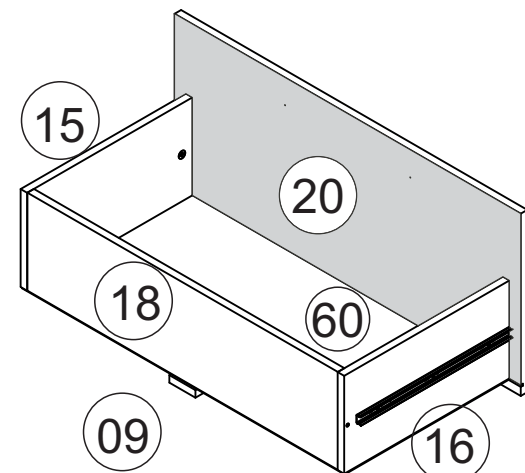
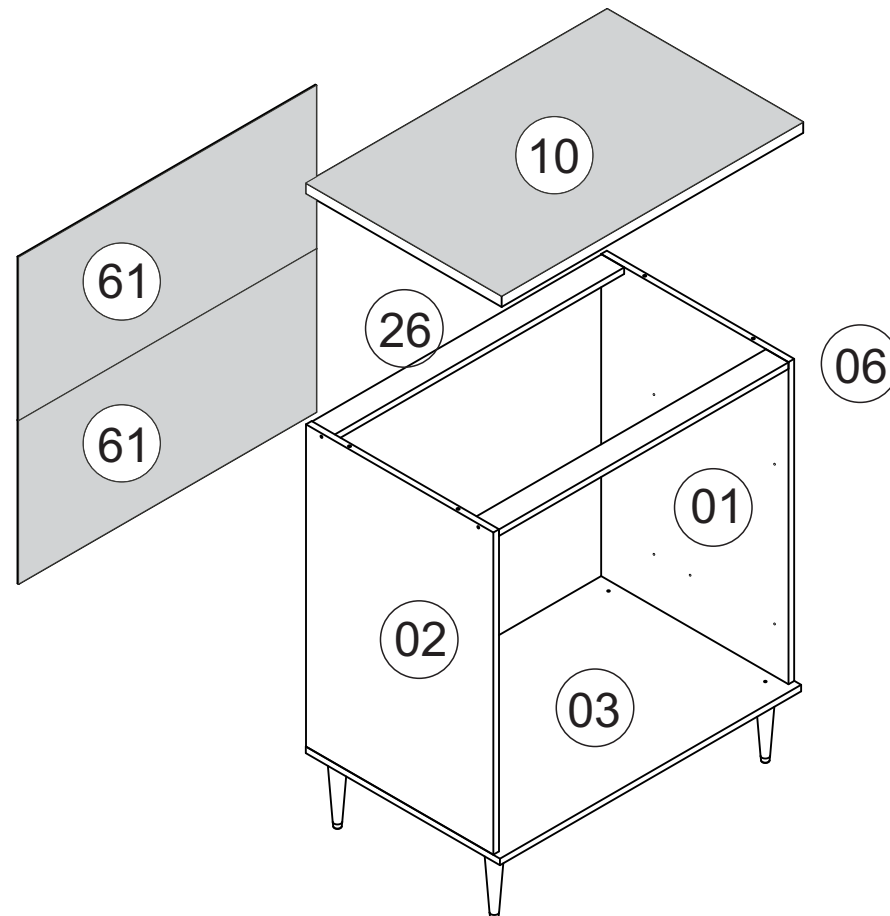

### FERRAMENTAS NECESSÁRIAS:

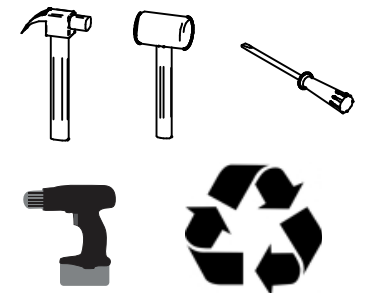

### FERRAMENTAS NECESSÁRIAS: HERRAMIENTAS NECESARIAS: NECESSARY TOOLS:

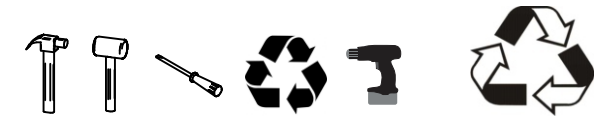

**"IMPORTANTE LER COM ATENÇÃO  
E GUARDAR PARA EVENTUAIS  
CONSULTAS".**

**"IMPORTANTE LEER CON ATENCIÓN Y GUARDAR PARA  
EVENTUALES CONSULTAS".**

**"IMPORTANT TO READ CAREFULLY AND SAVE FOR ANY  
QUERIES".**

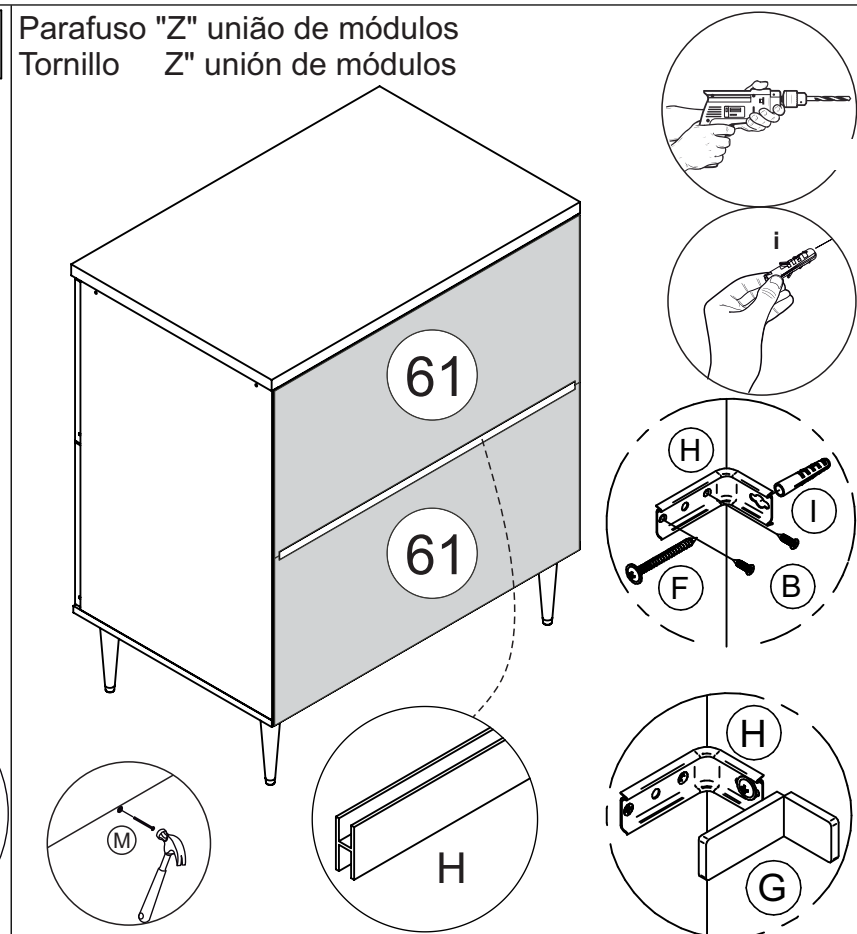
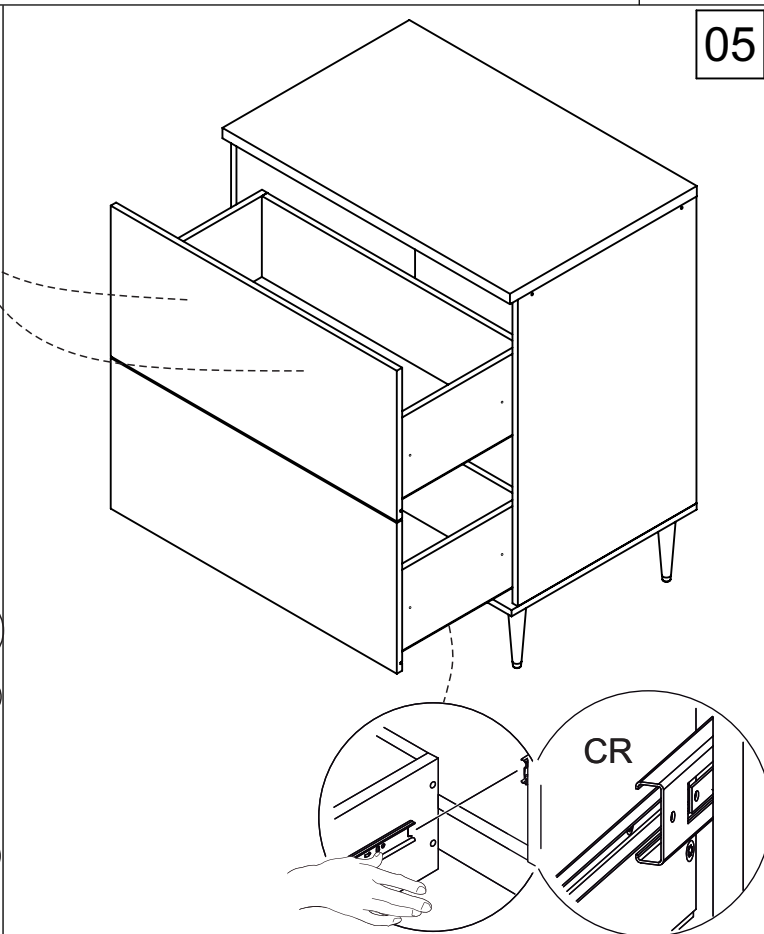
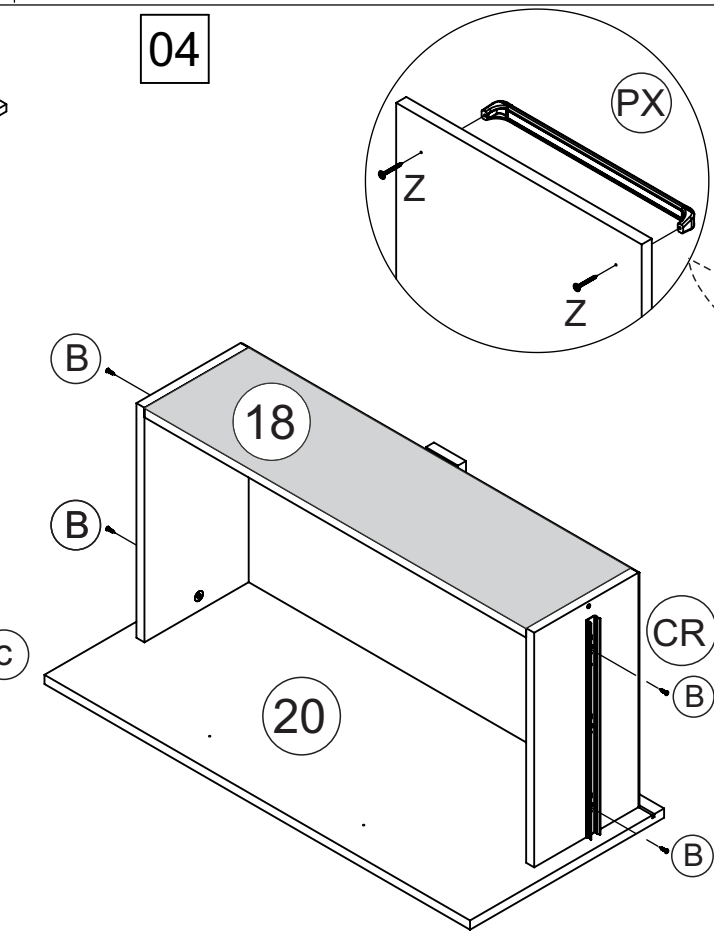
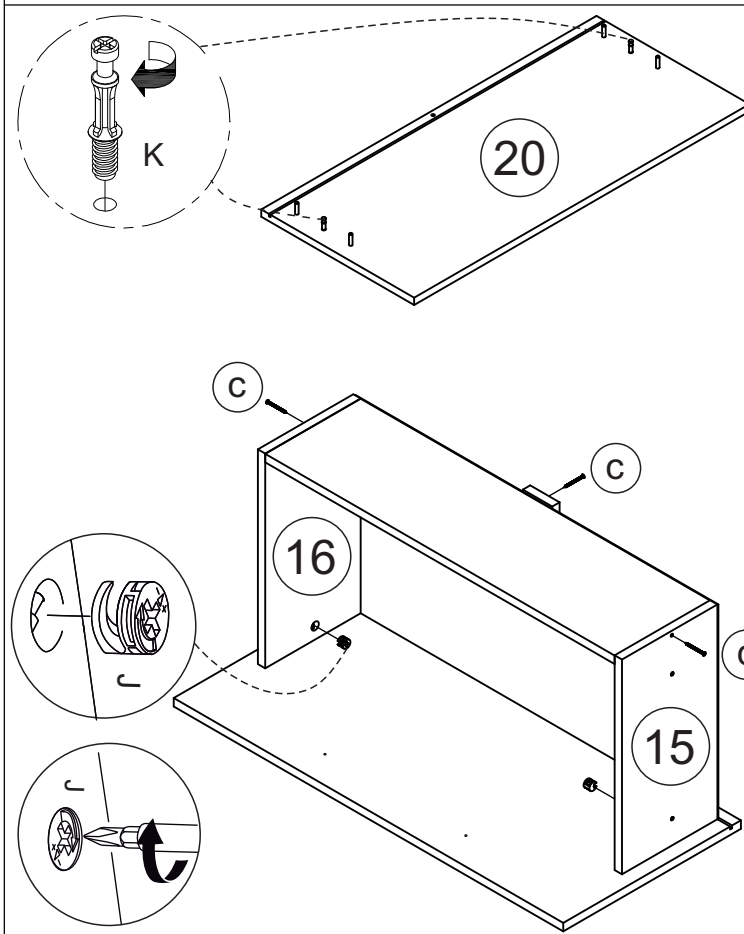
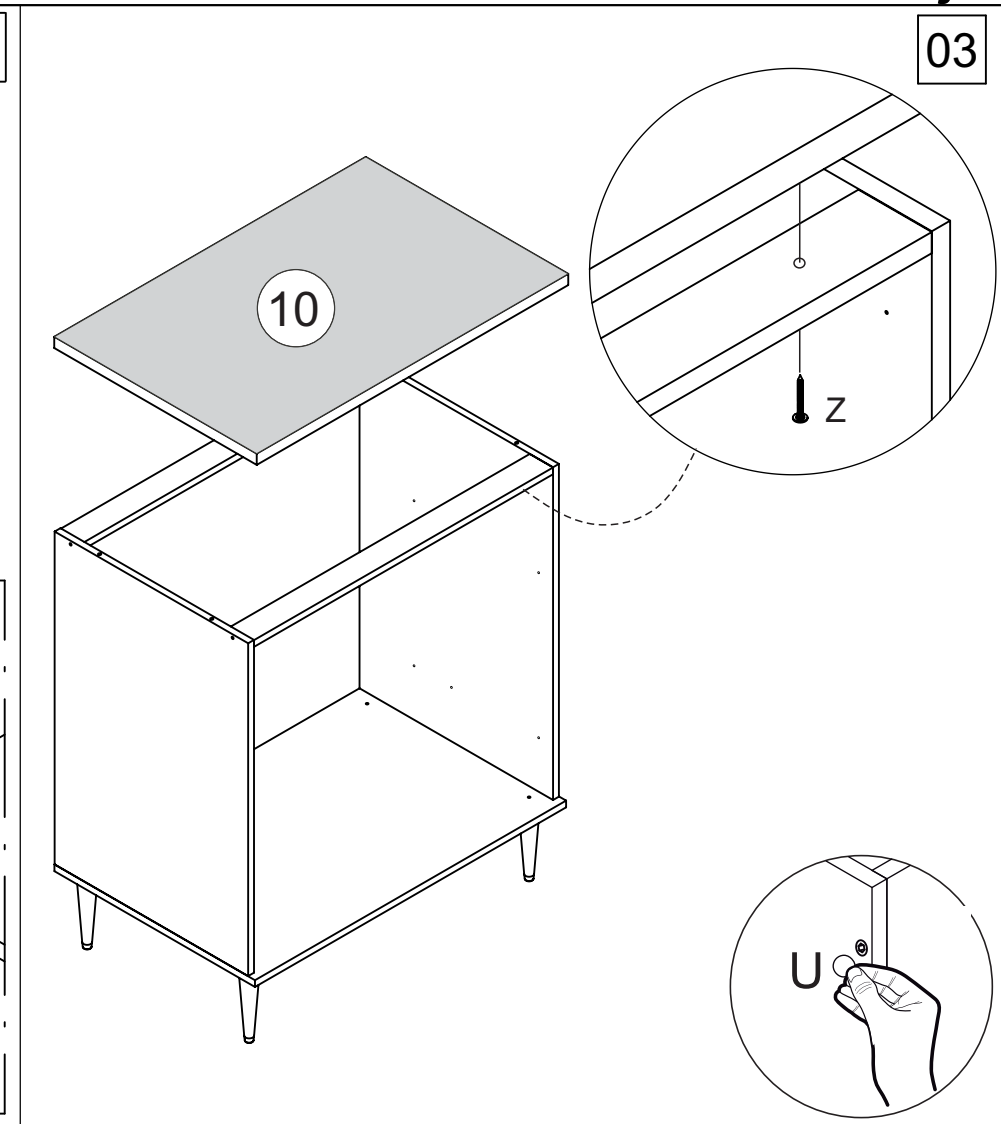
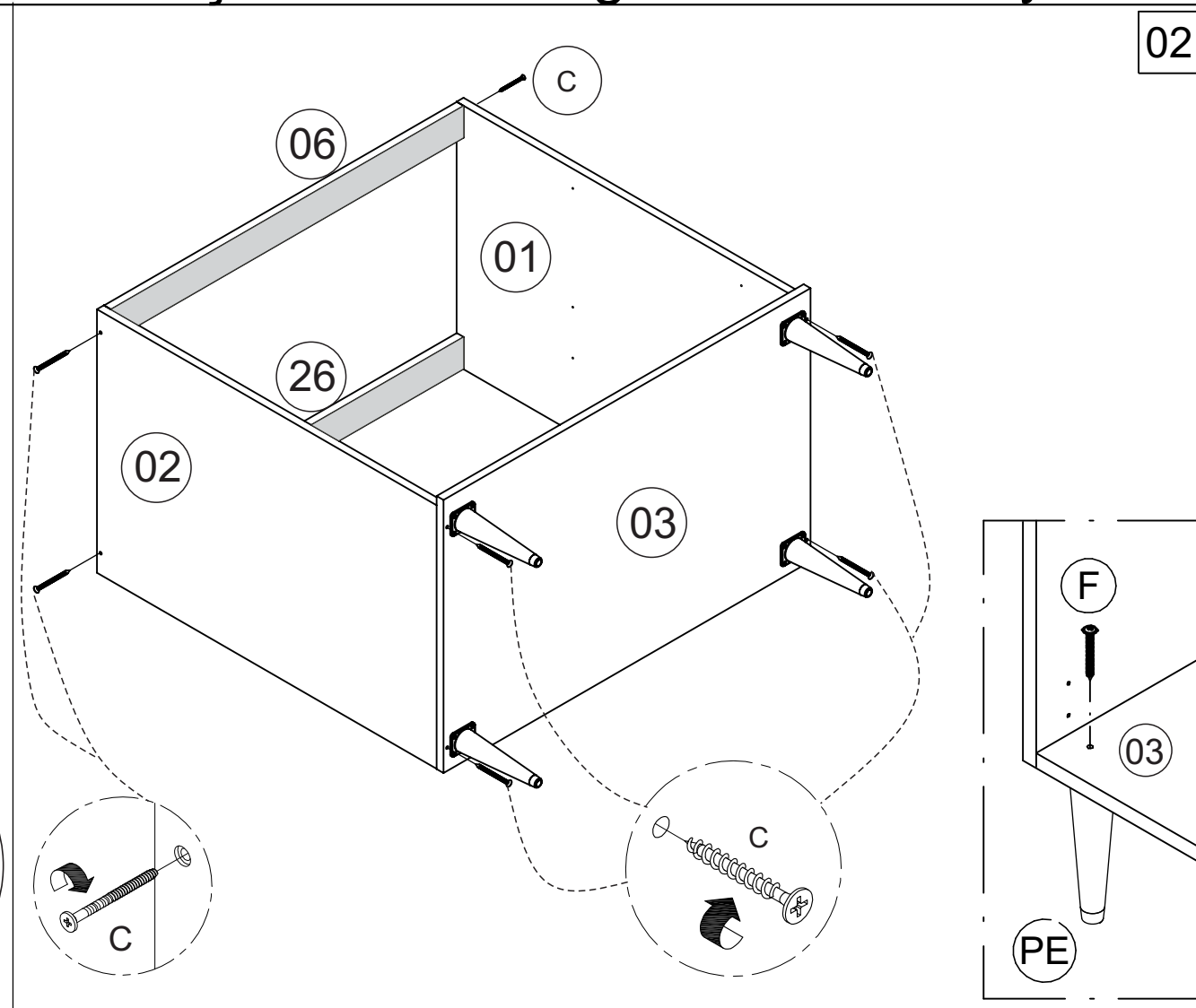
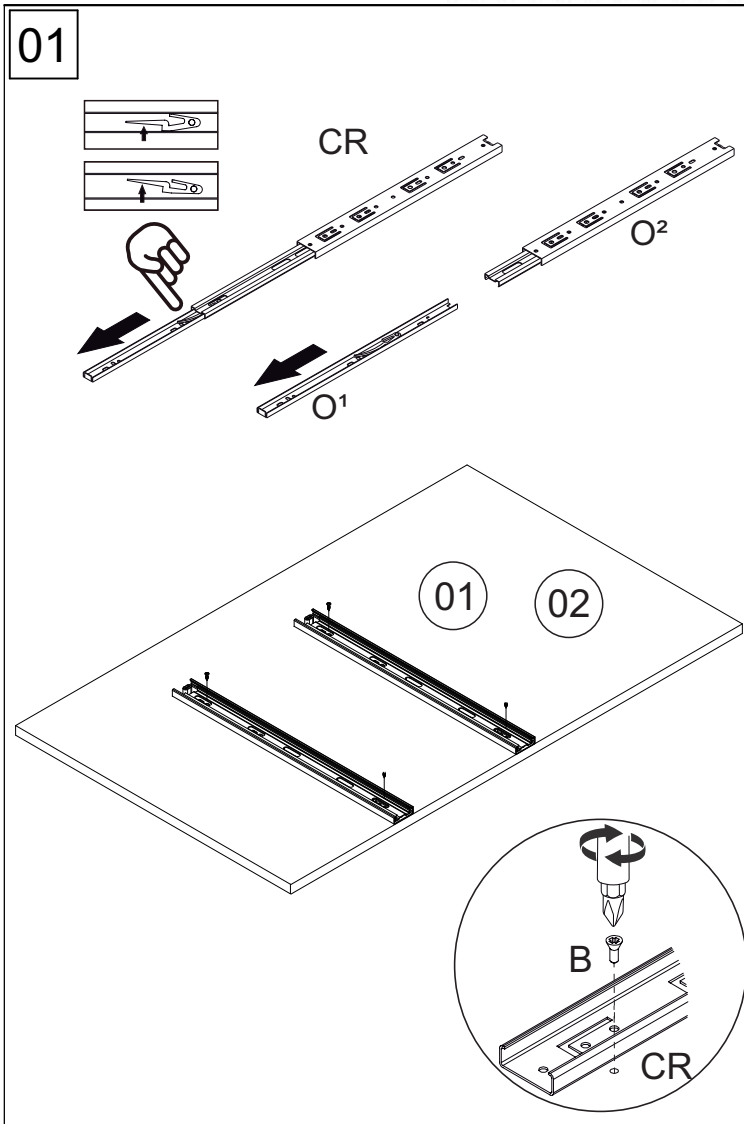

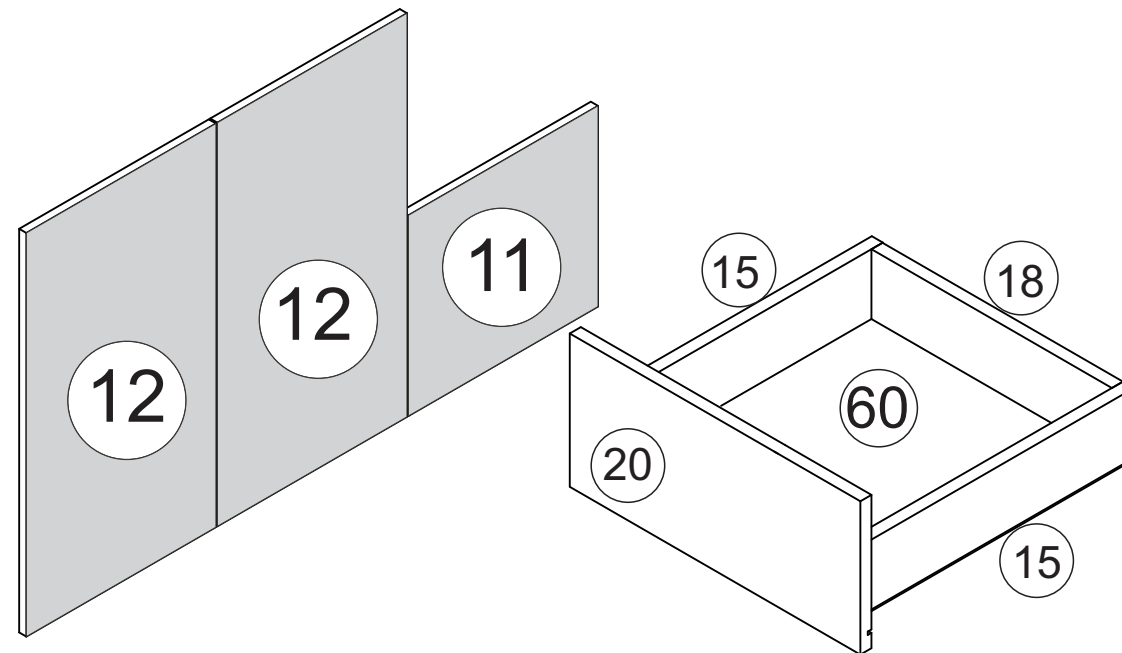
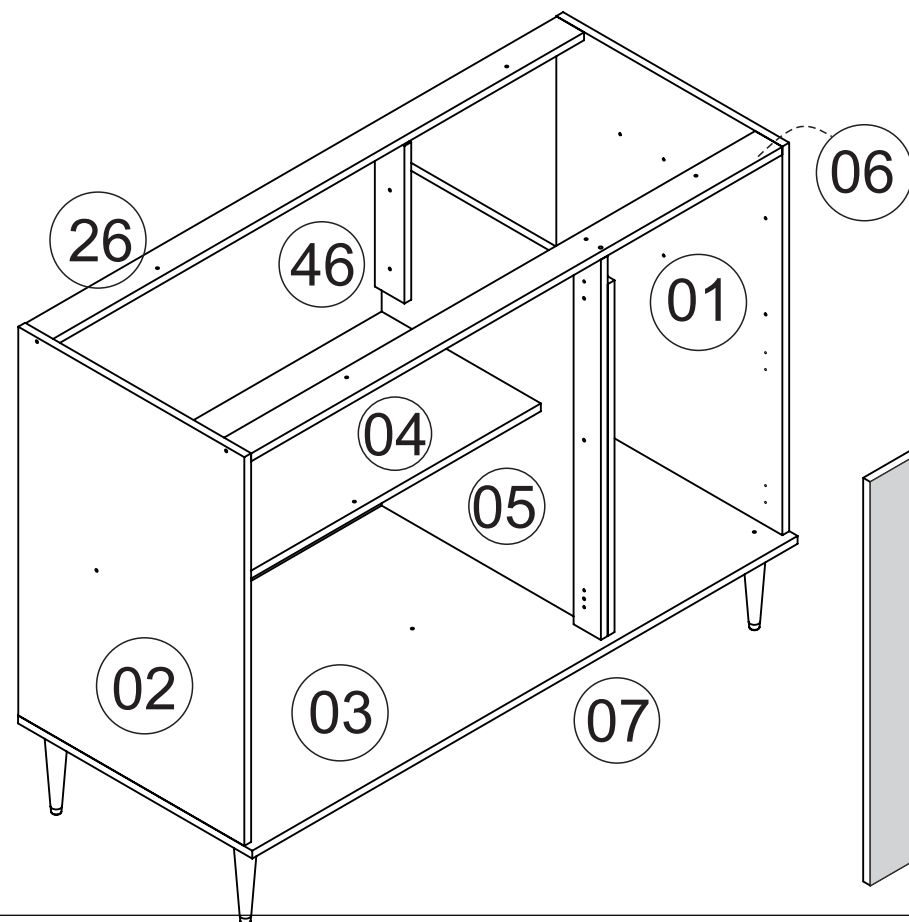
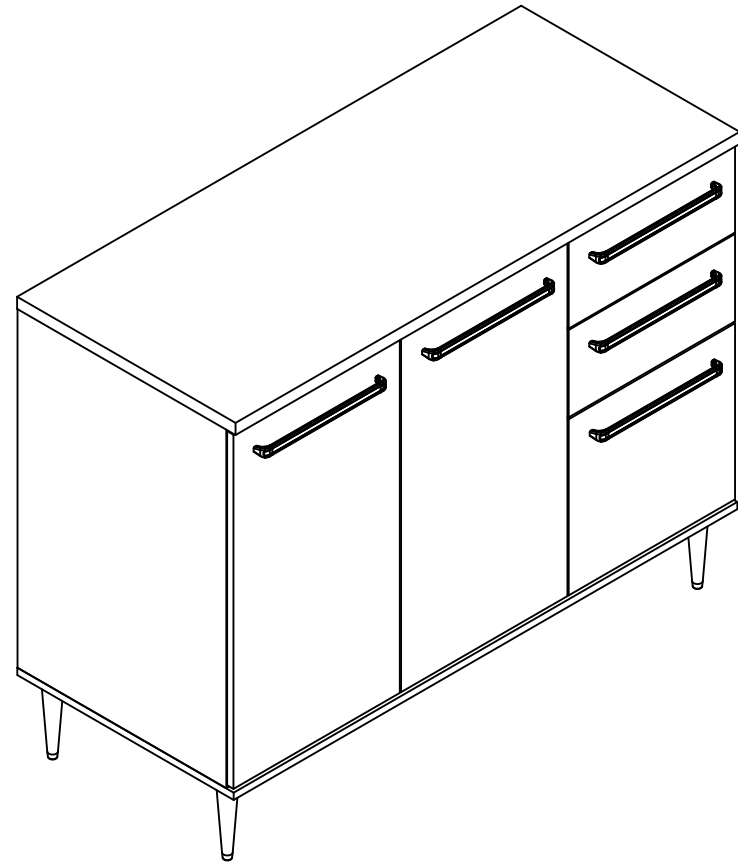

<b>A</b>		CAVILHA Ø6X30 CLAVIJA Ø6X30 WOOD DOWEL Ø6X30	<b>23</b>
<b>B</b>		PARAFUSO CC 3,5X14 TORNILLO CC 3,5X14 SCREW CC 3,5X14	<b>22</b>
<b>C</b>		PARAFUSO CC 3,5X40 TORNILLO CC 3,5X40 SCREW CC 3,5X40	<b>17</b>
<b>DB</b>		DOBRADIÇA BISAGRA HINGE	<b>06</b>
<b>F</b>		PARAFUSO CF 4,5X50 TORNILLO CF 4,5X50 SCREW CF 4,5X50	<b>06</b>
<b>M</b>		PREGO 10X10 NAIL	<b>80</b>
<b>Z</b>		PARAFUSO CF 3,5X25 TORNILLO CF 3,5 X 25 SCREW CF 3,5X25	<b>23</b>
<b>U</b>		ADESIVO TAPA FURO ADHESIVO STICKER	<b>05</b>
<b>V</b>		COLA PEGAMENTO GLUE	<b>01</b>
<b>PE</b>		PÉ PIÉ FOOT	<b>05</b>
<b>PX</b>		PUXADOR TIRADOR HANDLE	<b>05</b>
<b>G</b>		SUPORTE FIXAÇÃO SOPORTE DE FIJACIÓN FIXING SUPPORT	<b>01</b>
<b>H</b>		PROTEÇÃO SUP CANTONEIRA PROTECCIÓN ANGLE BRACKET	<b>01</b>
<b>I</b>		BUCHA PLÁSTICA CASQUILLO BUSHING	<b>01</b>
<b>CR</b>		CORREDIÇA 350 CORREDERA SLIDE	<b>02</b>
<b>X</b>		FIXADOR COSTA FIJADOR DE ESPALDA BACK FIXER	<b>08</b>

**Lista de ferragens**  
**Lista de materiales**  
**Hardware list**

**Lista de peças / Parts lists / Lista de piezas**

REF	DESC	COMP	LARG	ESP	QTD.
IS1500-01	LATERAL DIREITA/LADO DERECHO/RIGHT SIDE	740	497	15	1
IS1500-02	LATERAL ESQUERDA/LADO IZQUIERDO/LEFT SIDE	740	497	15	1
IS1500-03	BASE/BASE/BASE	1199	515	15	1
IS1500-04	PRATELEIRA/ESTANTE/SHELF	784	350	15	1
IS1500-05	DIVISAO/DIVISION/DIVISION	670	497	15	1
IS1500-06	TRAVESSA FRONTAL/TRAVESAN~I/LONG PLATE	1168	60	15	1
IS1500-07	PILASTRA/PILLAR/PILAR	724	60	15	1
IS1500-11	PORTA/PUERTA/DOOR	396	363	15	1
IS1500-12	PORTA/PUERTA/DOOR	396	730	15	2
IS1500-15	LATERAL GAVETA/CAJÓN LATERAL/SIDE DRAWER	380	82	15	4
IS1500-18	COSTA GAVETA/FONDO DEL CAJÓN/FONDO/BACK	314	82	15	2
IS1500-20	FRENTE GAVETA/FRENTE DE CAJÓN/DRAWER FRONT	396	180	15	2
IS1500-26	TRAVESSA TRASERA/TRAVESAN~I/LONG PLATE	1168	60	15	1
IS1500-46	TRAVESSA SUSTENTACAO/TRAVESAN~I/LONG PLATE	300	65	15	1
IS1500-60	COSTA/FONDO/BACK	383	342	3	2
IS1500-61	COSTA/FONDO/BACK	373	1190	3	2

<b>J</b>		TAMBOR MINIFIX TAMBOR MINIFIX MINIFIX DRUM	<b>04</b>
<b>K</b>		TAMBOR MINIFIX TORNILLO MINIFIXO MINIFIX SCREW	<b>04</b>



FERRAMENTAS NECESSÁRIAS:  
HERRAMIENTAS NECESARIAS:  
NECESSARY TOOLS:



**"IMPORTANTE LER COM ATENÇÃO E GUARDAR PARA EVENTUAIS CONSULTAS".**

"IMPORTANTE LEER CON ATENCIÓN Y GUARDAR PARA EVENTUALES CONSULTAS".

"IMPORTANT TO READ CAREFULLY AND SAVE FOR ANY QUERIES".



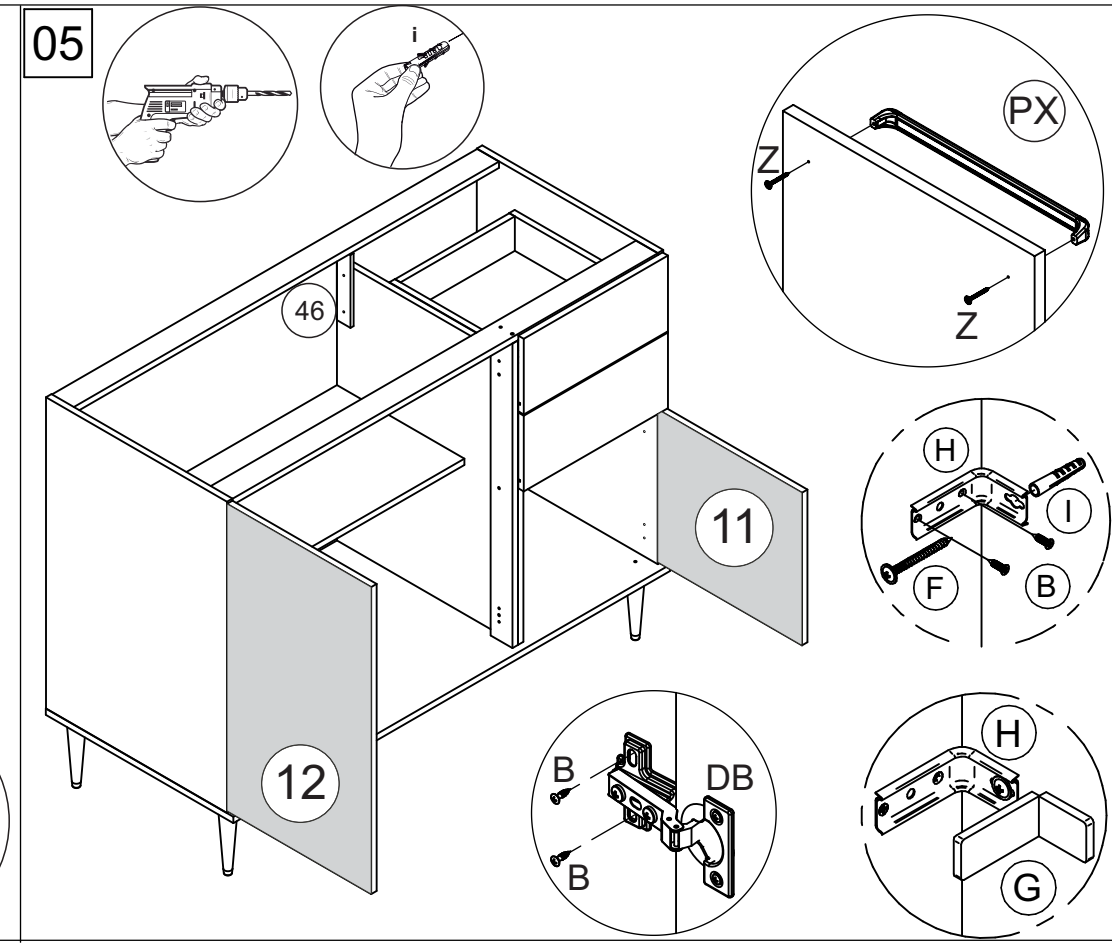
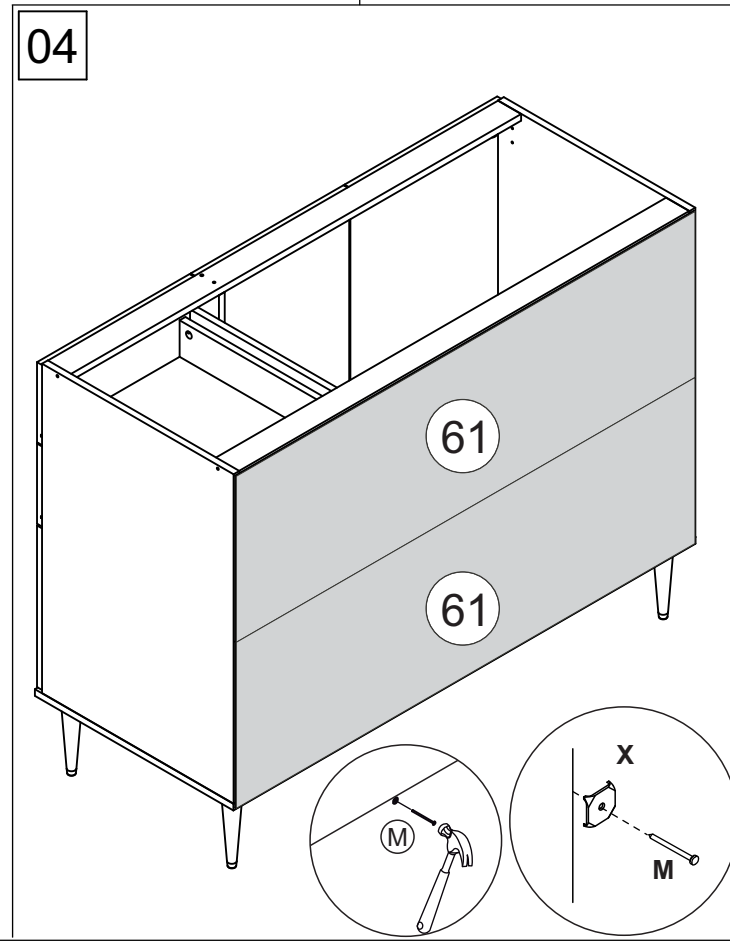
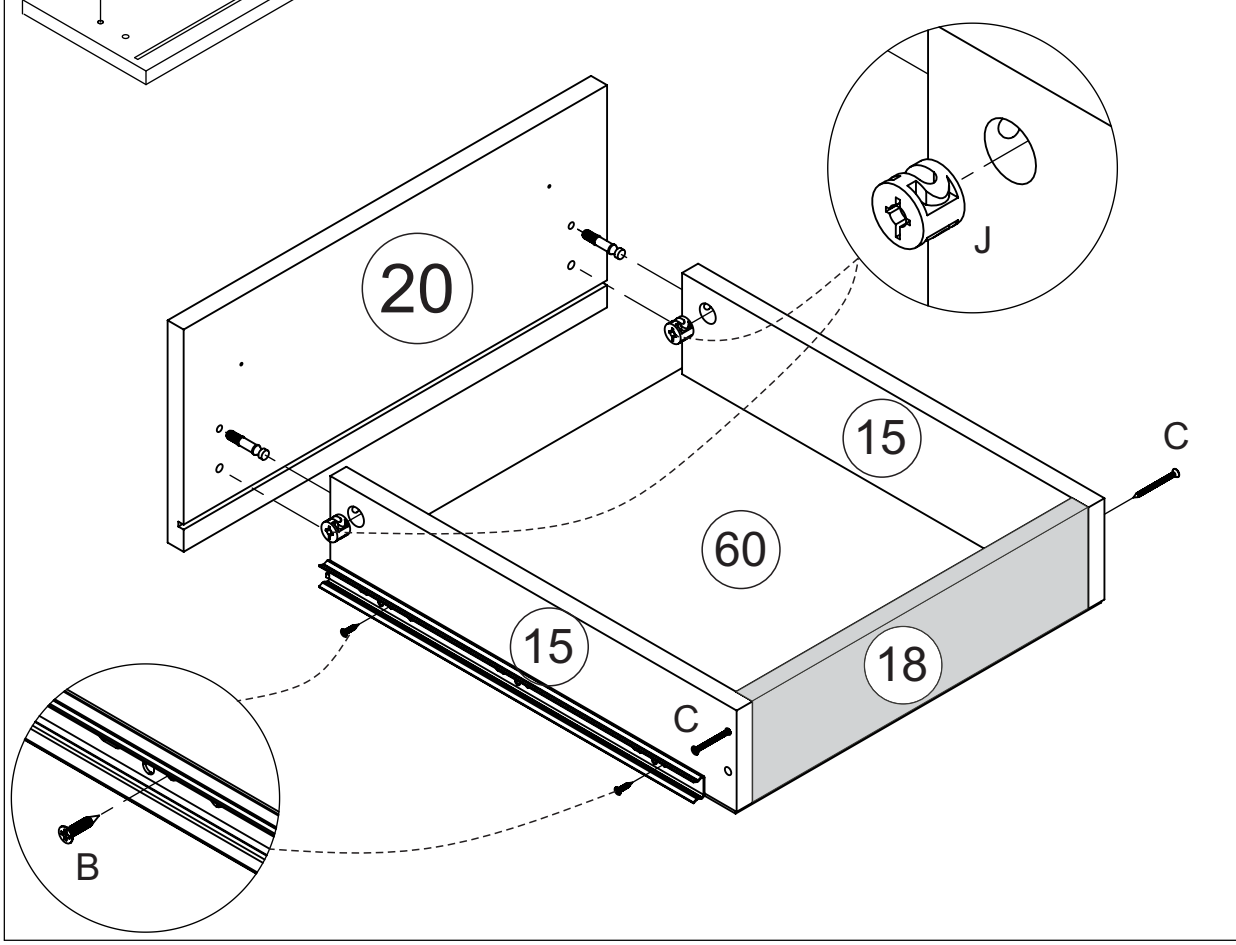
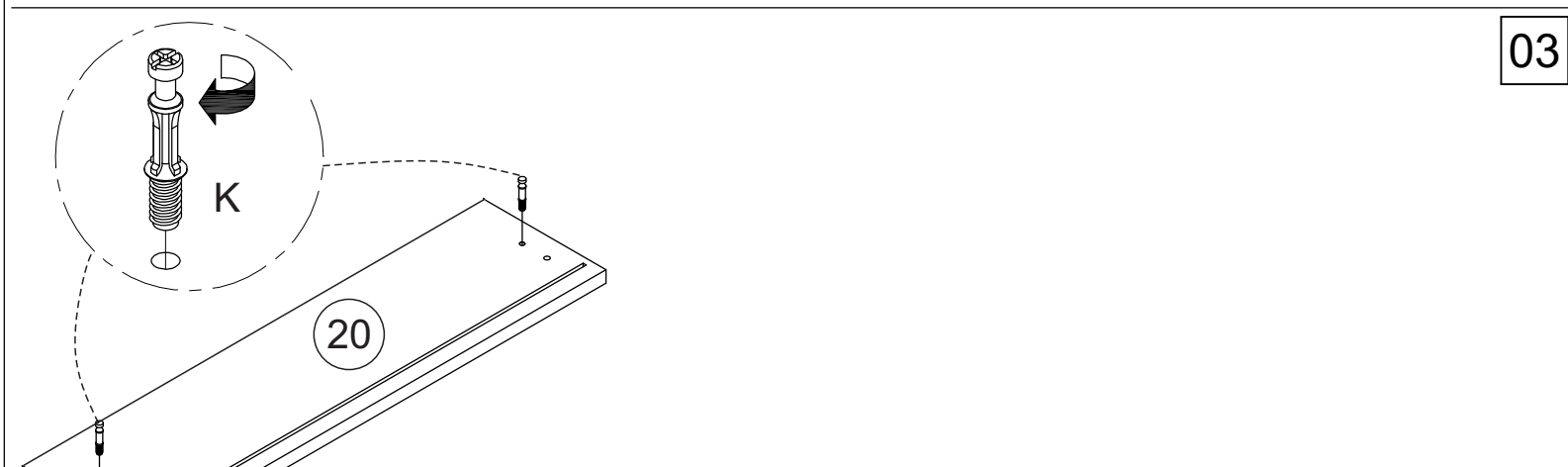
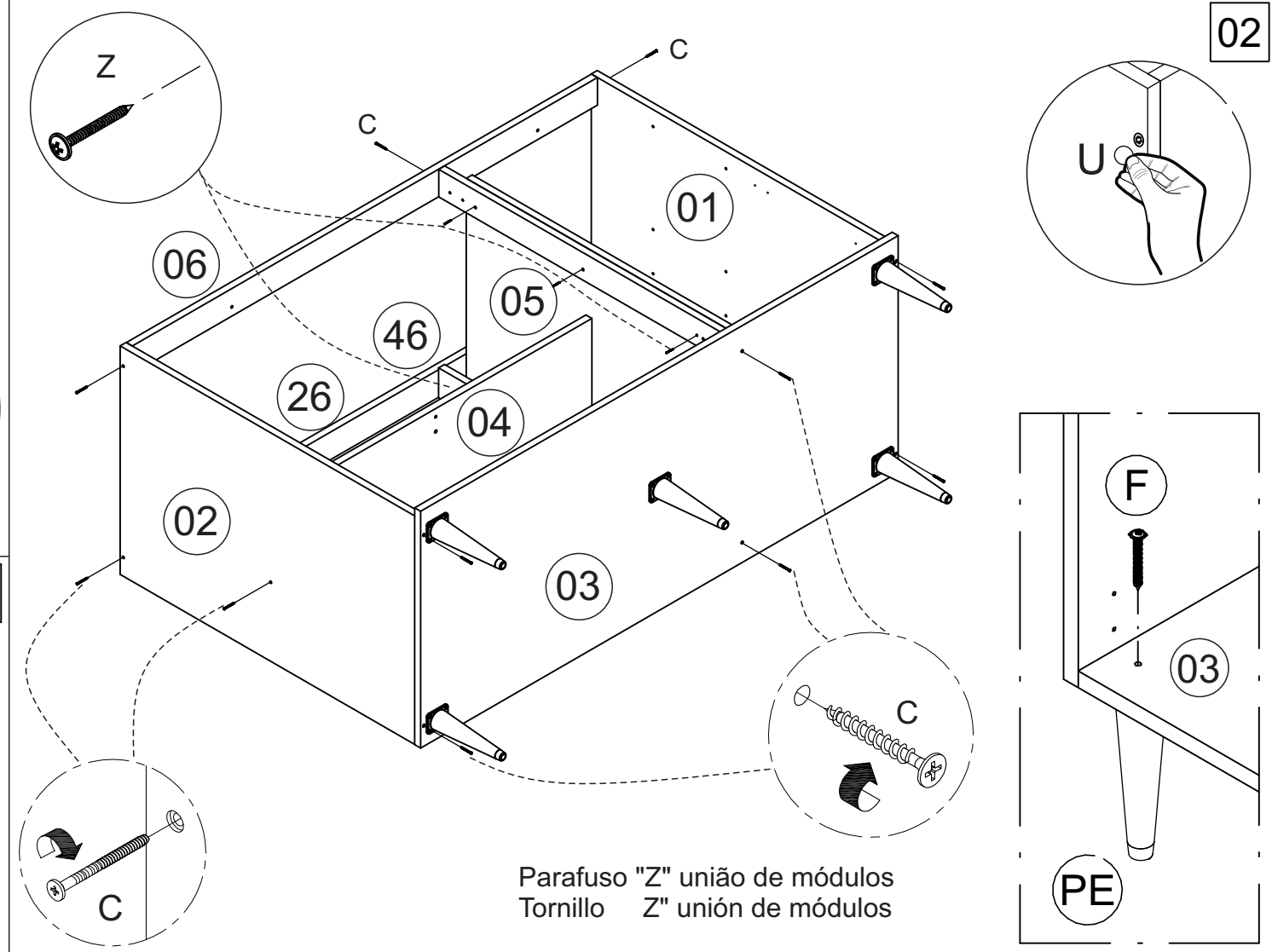
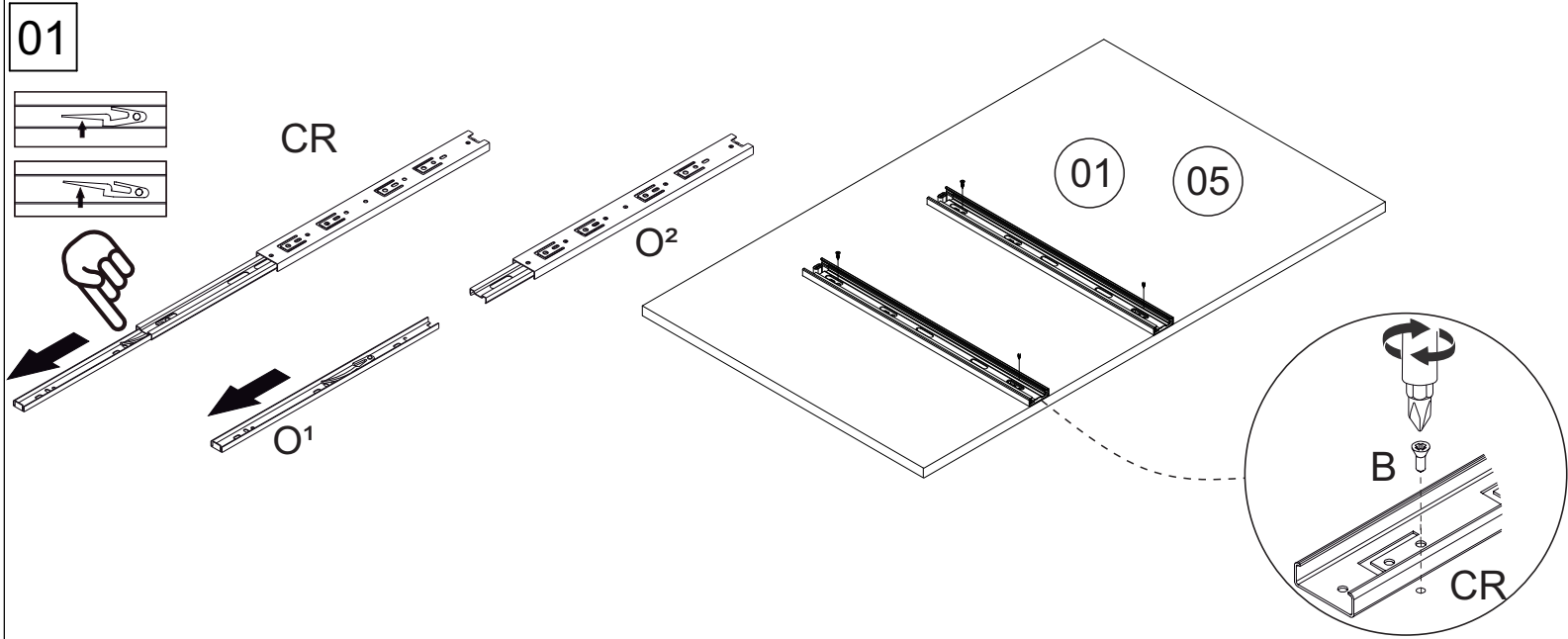

# IS 1630 Aereo 120

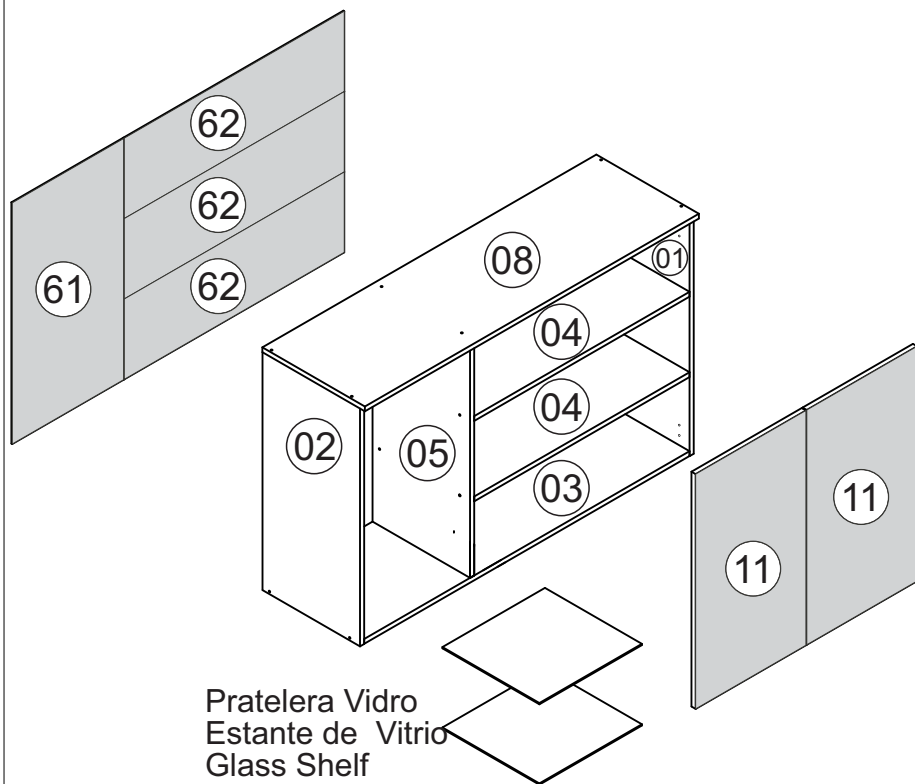
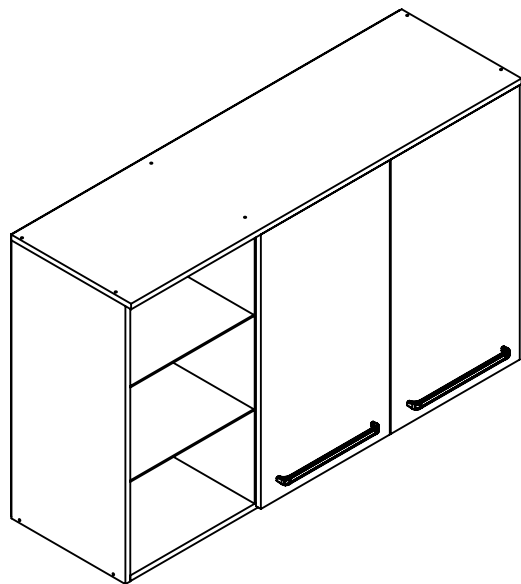

A		CAVILHA Ø6X30 CLAVIJA Ø6X30 WOOD DOWEL Ø6X30	20
B		PARAFUSO CC 4X14 TORNILLO CC 4X14 SCREW CC 4X14	06
C		PARAFUSO CC 4X40 TORNILLO CC 4X40 SCREW CC 4X40	20
DB		DOBRADIÇA BISAGRA HINGE	04
F		PARAFUSO CF 4,5X50 TORNILLO CF 4,5X50 SCREW CF 4,5X50	03
M		PREGO 10X10 CLAVO 10X10 NAIL	65
U		ADESIVO TAPA FURO ADHESIVO STICKER	06
X		FIXADOR COSTAS FIJADOR PRARA FONDO BACK SUPPORT	15
Z		PARAFUSO CC 4X30 TORNILLO CC 4X30 SCREW CC 4X30	08
G		SUPORTE FIXAÇÃO SOPORTE DE FIJACIÓN FIXING SUPPORT	03
H		PROTEÇÃO SUP CANTONEIRA PROTECCIÓN ANGLE BRACKET	03
I		BUCHA PLÁSTICA CASQUILLO BUSHING	03
PX		PUXADOR TIRADOR HANDLE	02
V		COLA PEGAMENTO GLUE	01
w		PARAFUSO CF 4,5X50 TORNILLO CF 4,5X50 SCREW CF 4,5X50	08

Assembly Instructions / Instrucciones de Montaje  
Instruções de Montagem /

01

FERRAMENTAS NECESSÁRIAS:  
HERRAMIENTAS NECESARIAS:  
NECESSARY TOOLS:



**"IMPORTANTE LER COM ATENÇÃO  
E GUARDAR PARA EVENTUAIS  
CONSULTAS".**

**"IMPORTANTE LEER CON ATENCIÓN Y GUARDAR PARA  
EVENTUALES CONSULTAS".**  
**"IMPORTANT TO READ CAREFULLY AND SAVE FOR ANY  
QUERIES".**

Lista de peças / Parts lists / Lista de piezas

REF	DESC	COMP	LARG	ESP	QTD.
IS1630-01	LATERAL DIREITA/LADO DERECHO/RIGHT SIDE	740	350	15	1
IS1630-02	LATERAL ESQUERDA/LADO IZQUIERDO/LEFT SIDE	740	350	15	1
IS1630-03	BASE/BASE/BASE	1168	350	15	1
IS1630-04	PRATELERA/ESTANTE/DIVISION	771	350	15	2
IS1630-05	DIVISAO/DIVISION/DIVISION	724	350	15	1
IS1630-08	CHAPEU/SOMBREIRO/HAT	1200	368	15	1
IS1630-11	PORTA/PUERTA/DOOR	396	730	15	2
IS1630-61	COSTA/FONDO/BACK	400	750	3	1
IS1630-62	COSTA/FONDO/BACK	250	790	3	3



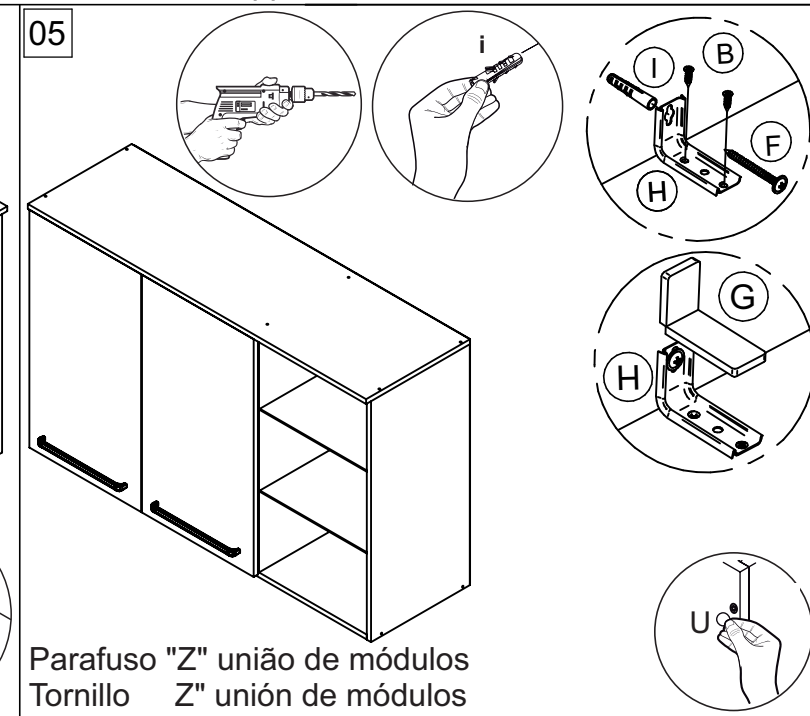
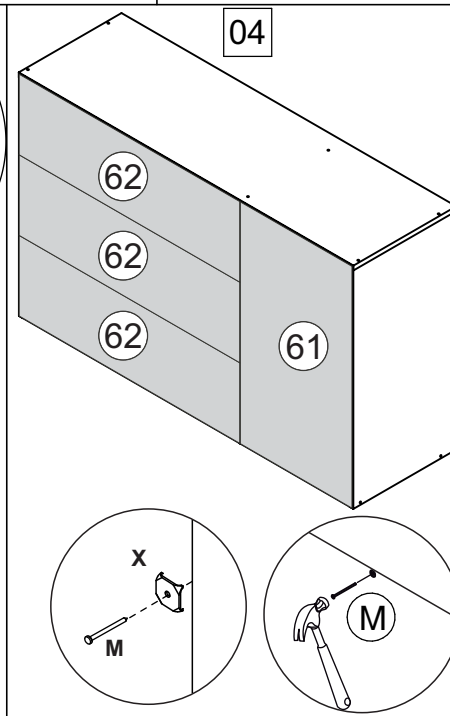
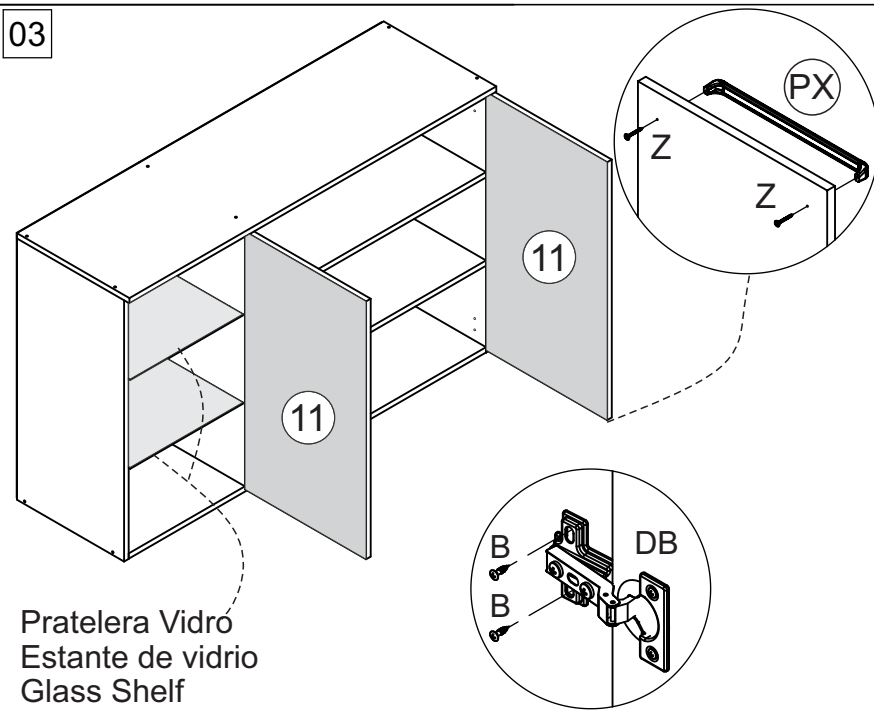
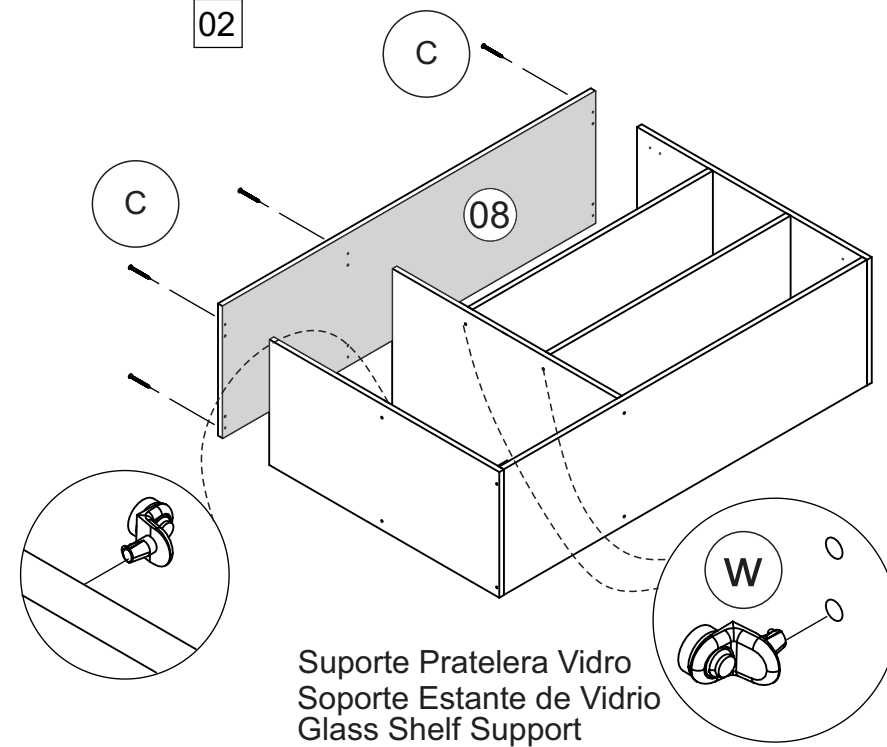
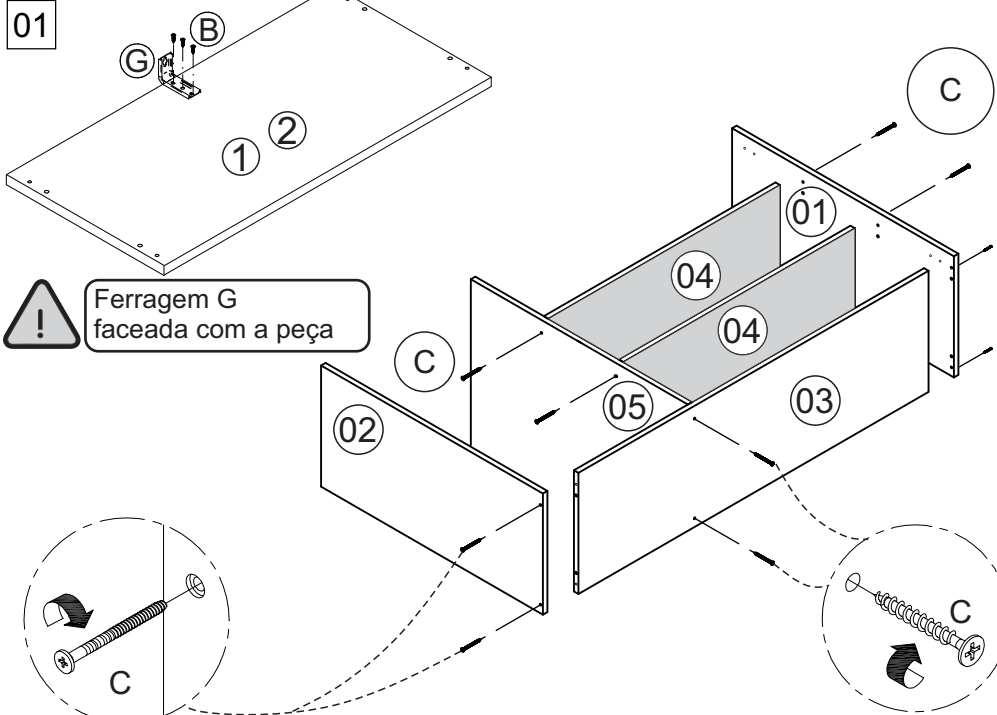

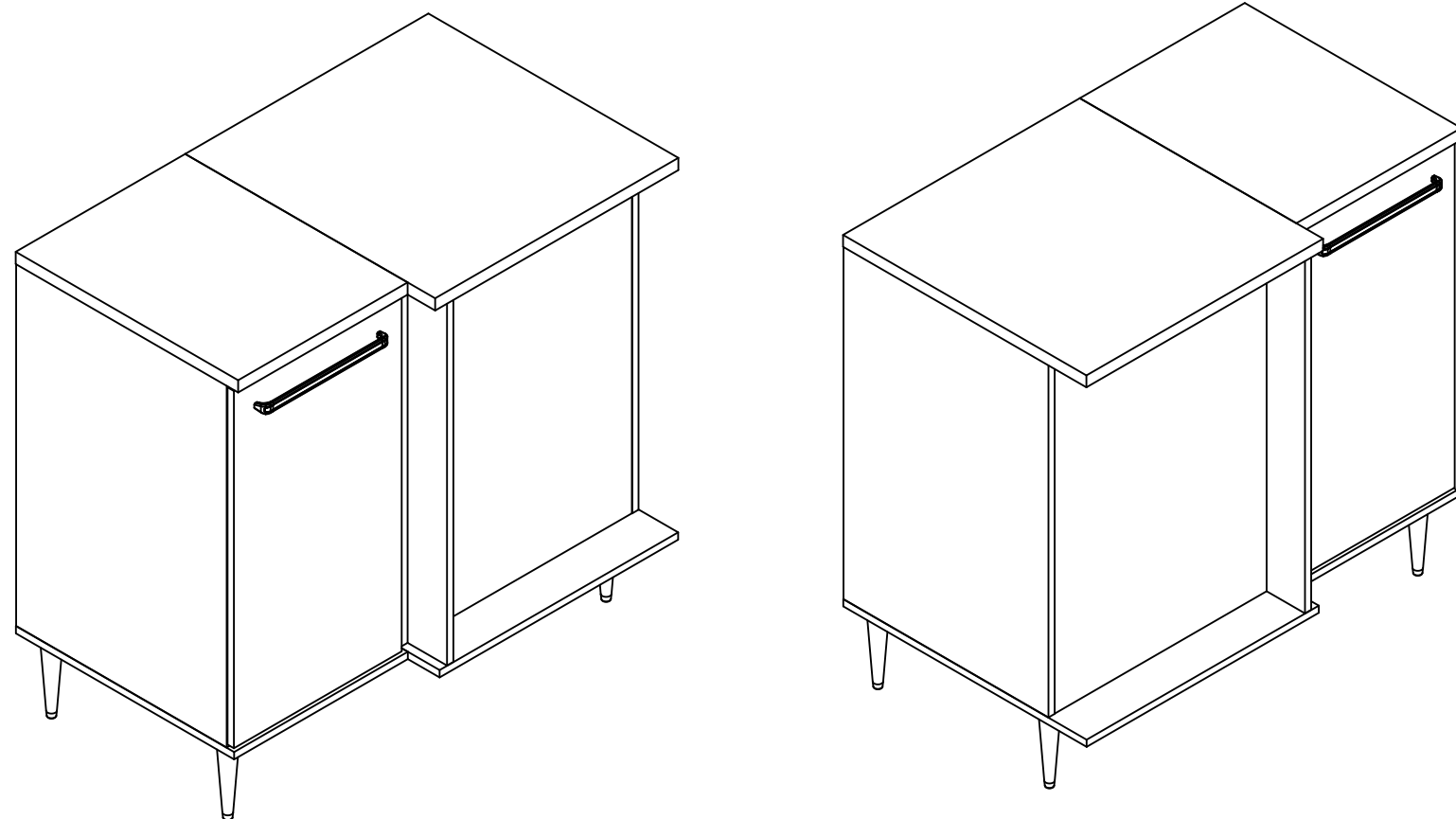

### Lista de peças / Parts lists / Lista de piezas

REF	DESC	COMP	LARG	ESP	QTD.
IS1515-01	LATERAL DIREITA/LADO DERECHO/RIGHT SIDE	740	497	15	1
IS1515-02	LATERAL ESQUERDA/LADO IZQUIERDO/LEFT SIDE	740	497	15	1
IS1515-03	BASE/BASE/BASE	590	515	15	1
IS1515-04	PRATELERA/ESTANTE/SHELF	350	942	15	1
IS1515-06	TRAVESSA FRONTAL/PLATO/PLATTER	364	60	15	1
IS1515-07	PILASTRA EXTERNA/PILASTO EXTERNO	740	93	15	1
IS1515-10	TAMPO/TAPA/TOP	590	520	25	1
IS1515-12	PORTA /PUERTA/DOOR	396	730	15	1
IS1515-21	LATERAL /LADO/SIDE	740	578	15	1
IS1515-26	TRAVESSA TRASERA/PLATO/PLATTER	60	942	15	1
IS1515-30	TAMPO/TAPA/TOP	454	520	25	1
IS1515-33	BASE/BASE/BASE	458	515	15	1
IS1515-61	COSTA/FONDO/BACK	966	350	3	1

### Lista de ferragens Lista de materiales Hardware list

A		CAVILHA Ø6X30 CLAVIJA Ø6X30 WOOD DOWEL Ø6X30	11
B		PARAFUSO CC 3,5X14 TORNILLO CC 3,5X14 SCREW CC 3,5X14	30
C		PARAFUSO CC 3,5X40 TORNILLO CC 3,5X40 SCREW CC 3,5X40	14
DB		DOBRADIÇA BISAGRA HINGE	02
F		PARAFUSO CF 4,5X50 TORNILLO CF 4,5X50 SCREW CF 4,5X50	06
Z		PARAFUSO CF 3,5X25 TORNILLO CF 3,5X25 SCREW CF 3,5X25	13
U		ADESIVO TAPA FURO ADHESIVO STICKER	06
M		PREGO 10X10 CLAVO 10X10 NAIL	35
V		COLA PEGAMENTO GLUE	01
PX		PUXADOR TIRADOR HANDLE	01
PE		PÉ PIE FOOT	05
E		CHAPA FIXAÇÃO PLACA DE FIJACIÓN FIXING PLATE	03
L		CANTONERA ESQUINERO CORNER	08
S		SUPORTE PRATELERA SOPORTE DE ESTANTE SHELF SUPPORT	04

FERRAMENTAS NECESSÁRIAS:  
HERRAMIENTAS NECESARIAS:  
NECESSARY TOOLS:



**"IMPORTANTE LER COM ATENÇÃO  
E GUARDAR PARA EVENTUAIS  
CONSULTAS".**

**"IMPORTANTE LEER CON ATENCIÓN Y GUARDAR PARA  
EVENTUALES CONSULTAS".**  
**"IMPORTANT TO READ CAREFULLY AND SAVE FOR ANY  
QUERIES".**

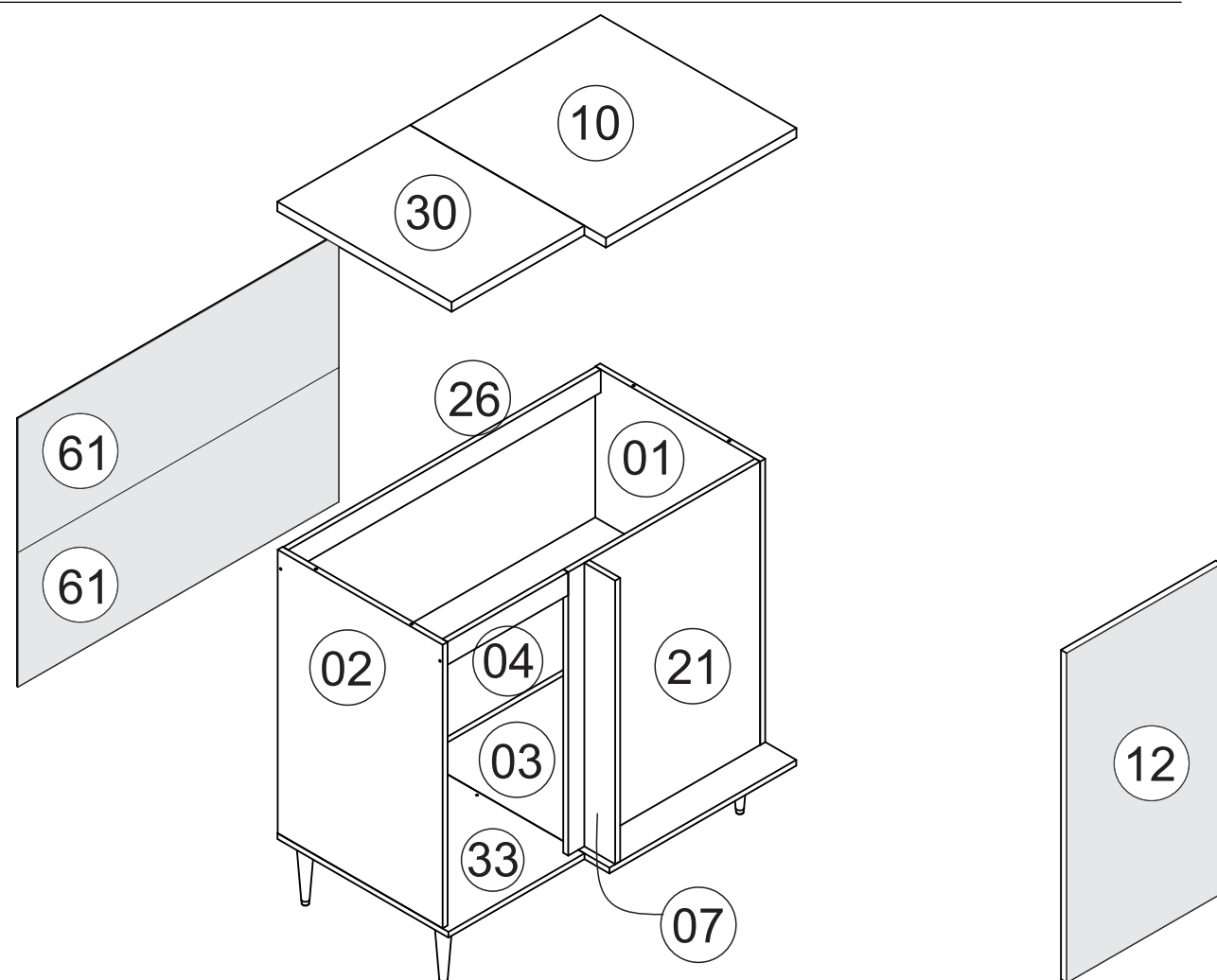

G		PROTEÇÃO SUP CANTONEIRA PROTECCIÓN ANGLE BRACKET	01
H		SUPORTE FIXAÇÃO SOPORTE DE FIJACIÓN FIXING SUPPORT	01
I		BUCHA PLÁSTICA CASQUILLO BUSHING	01

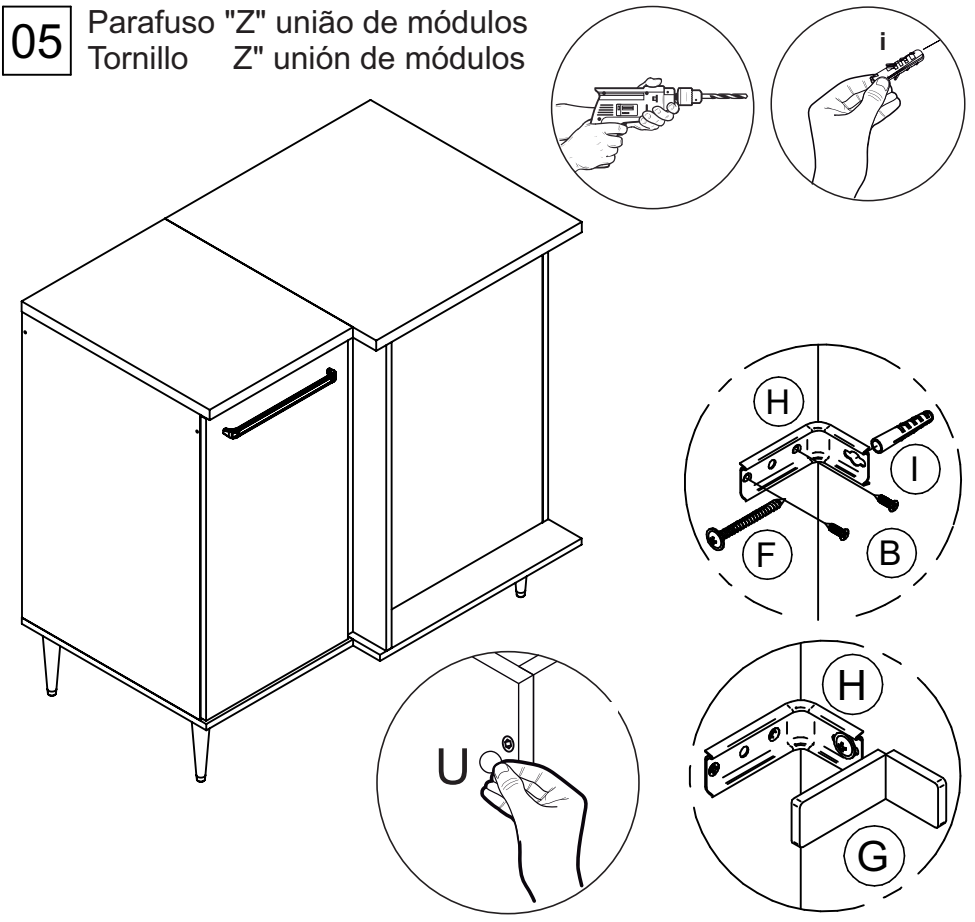
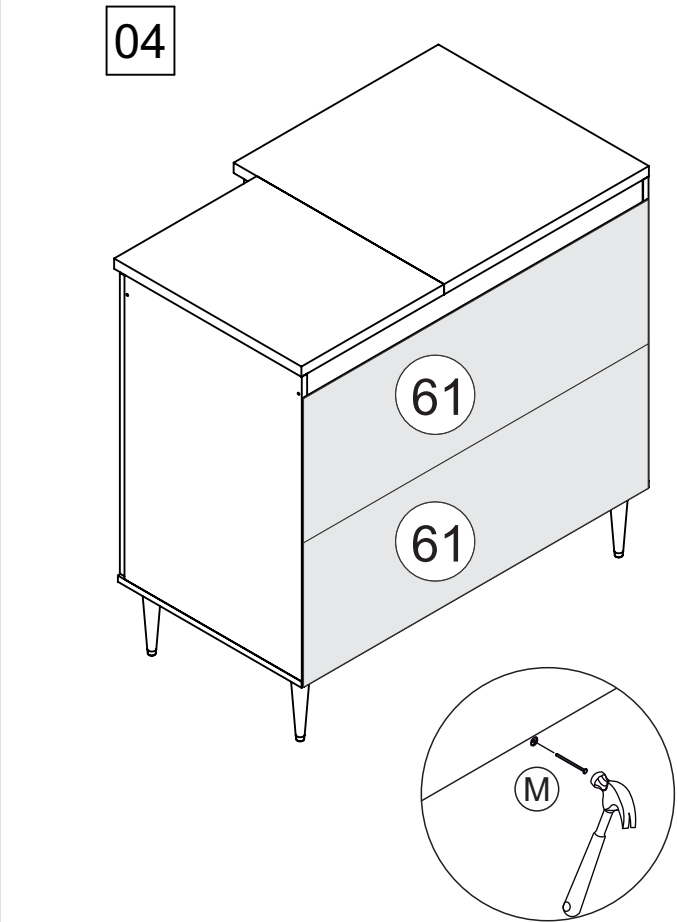
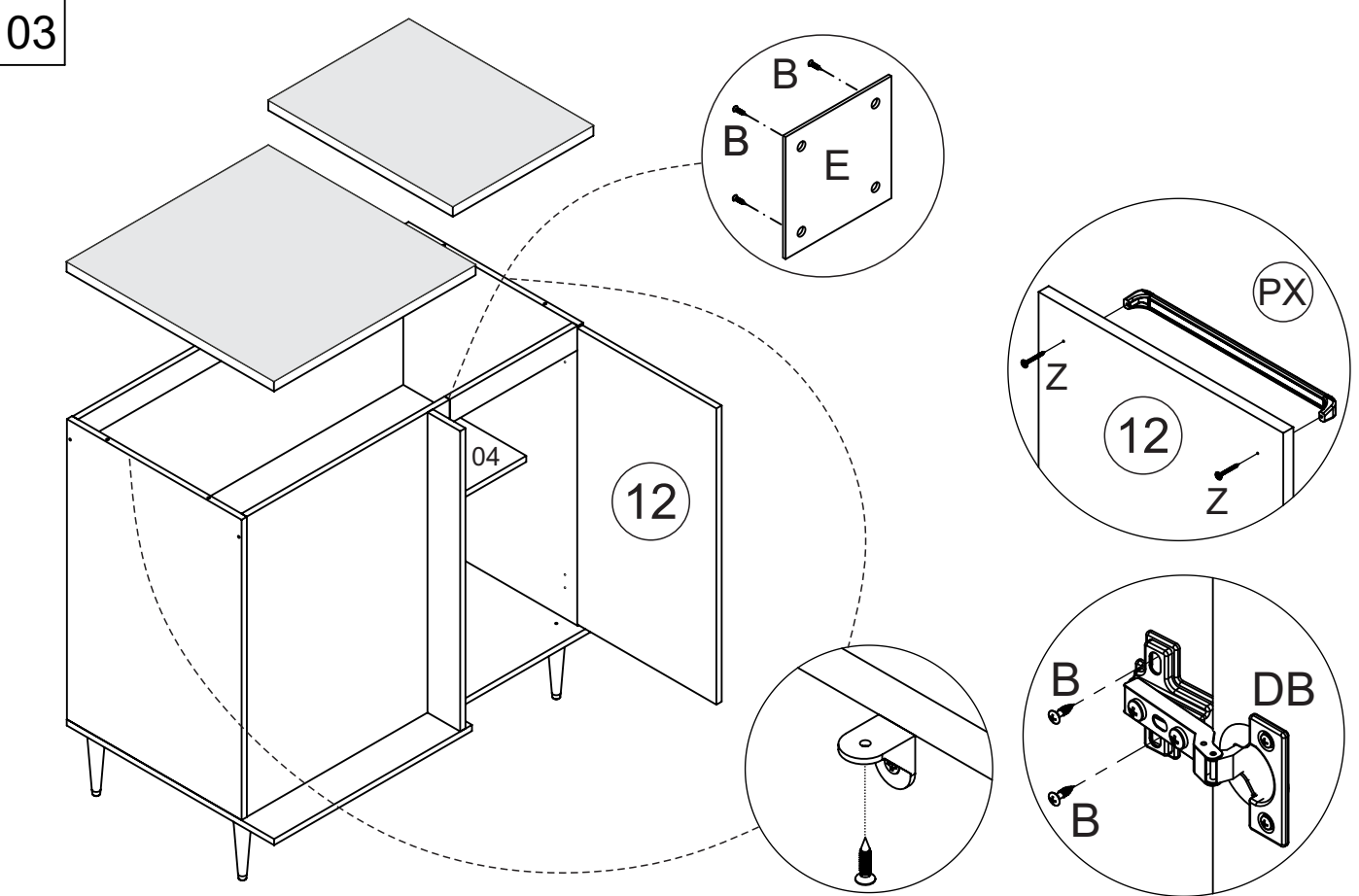
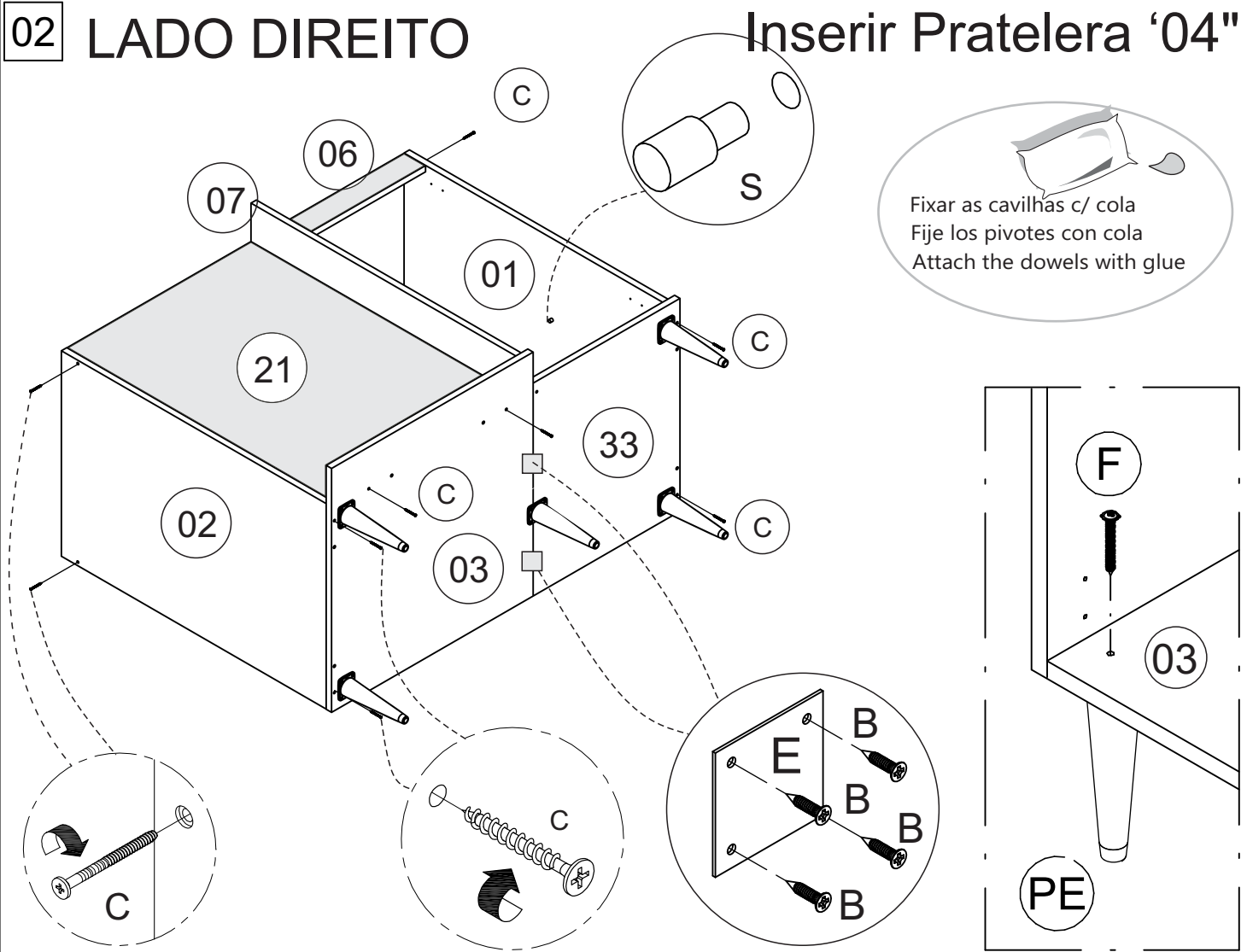
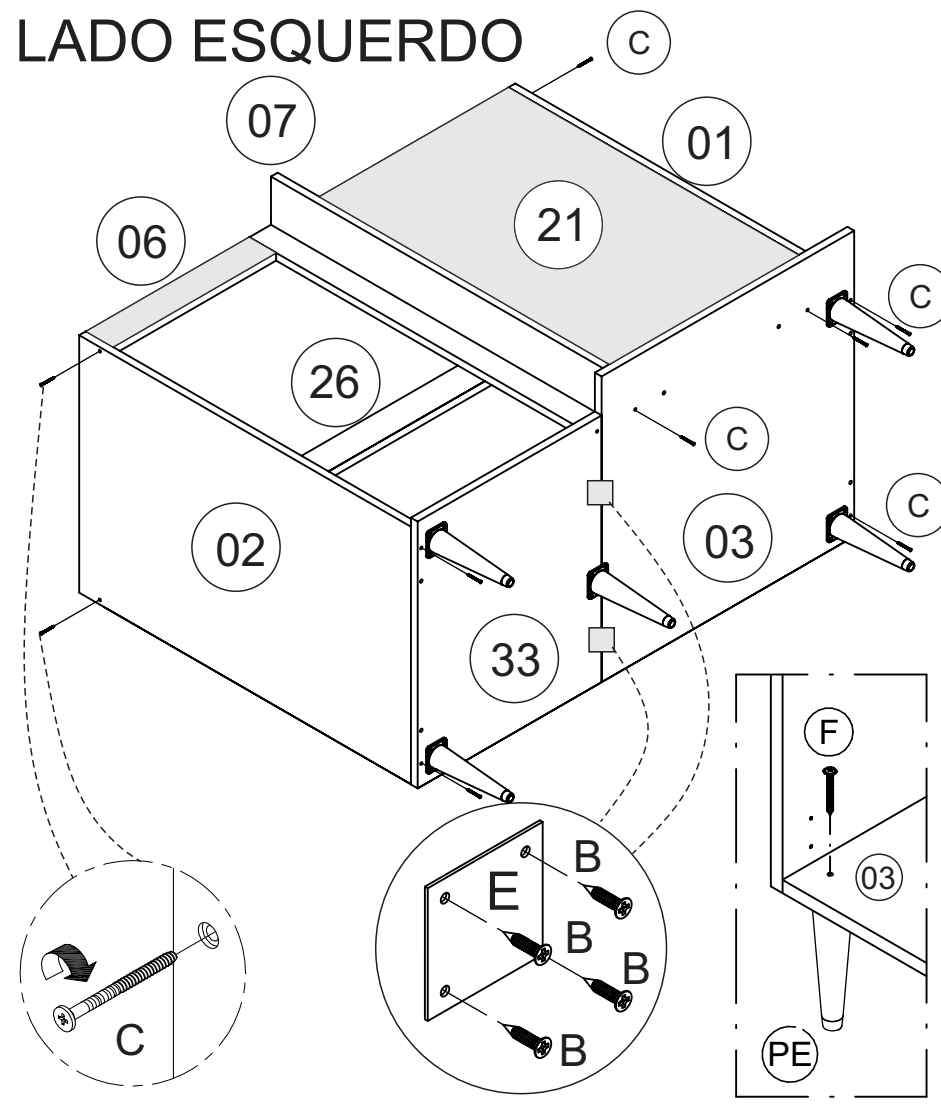
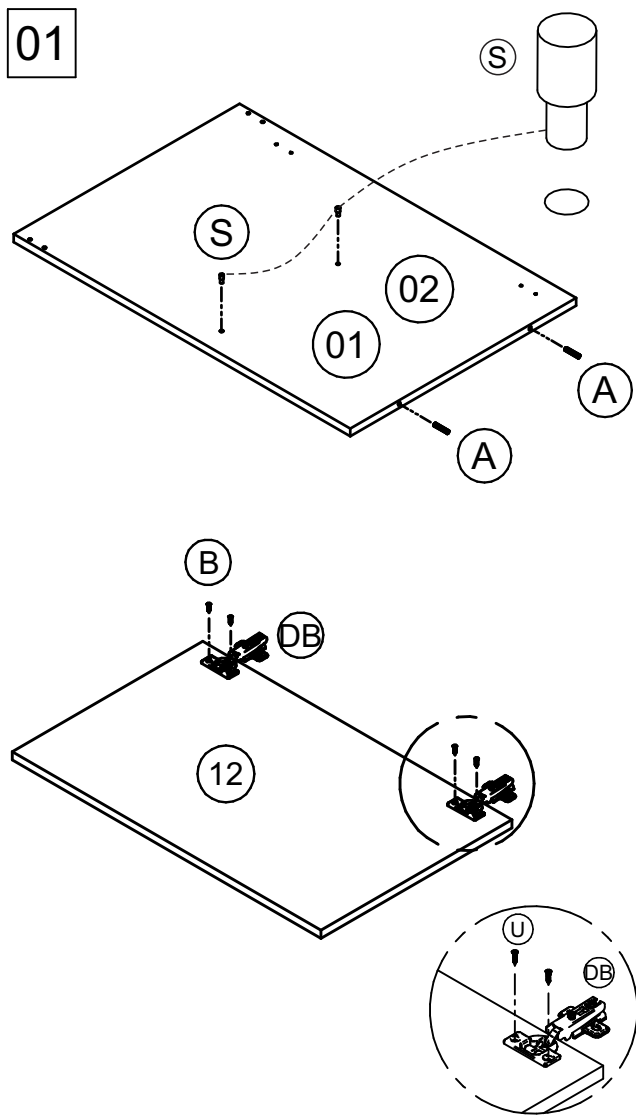

Lista de peças / Parts lists / Lista de piezas

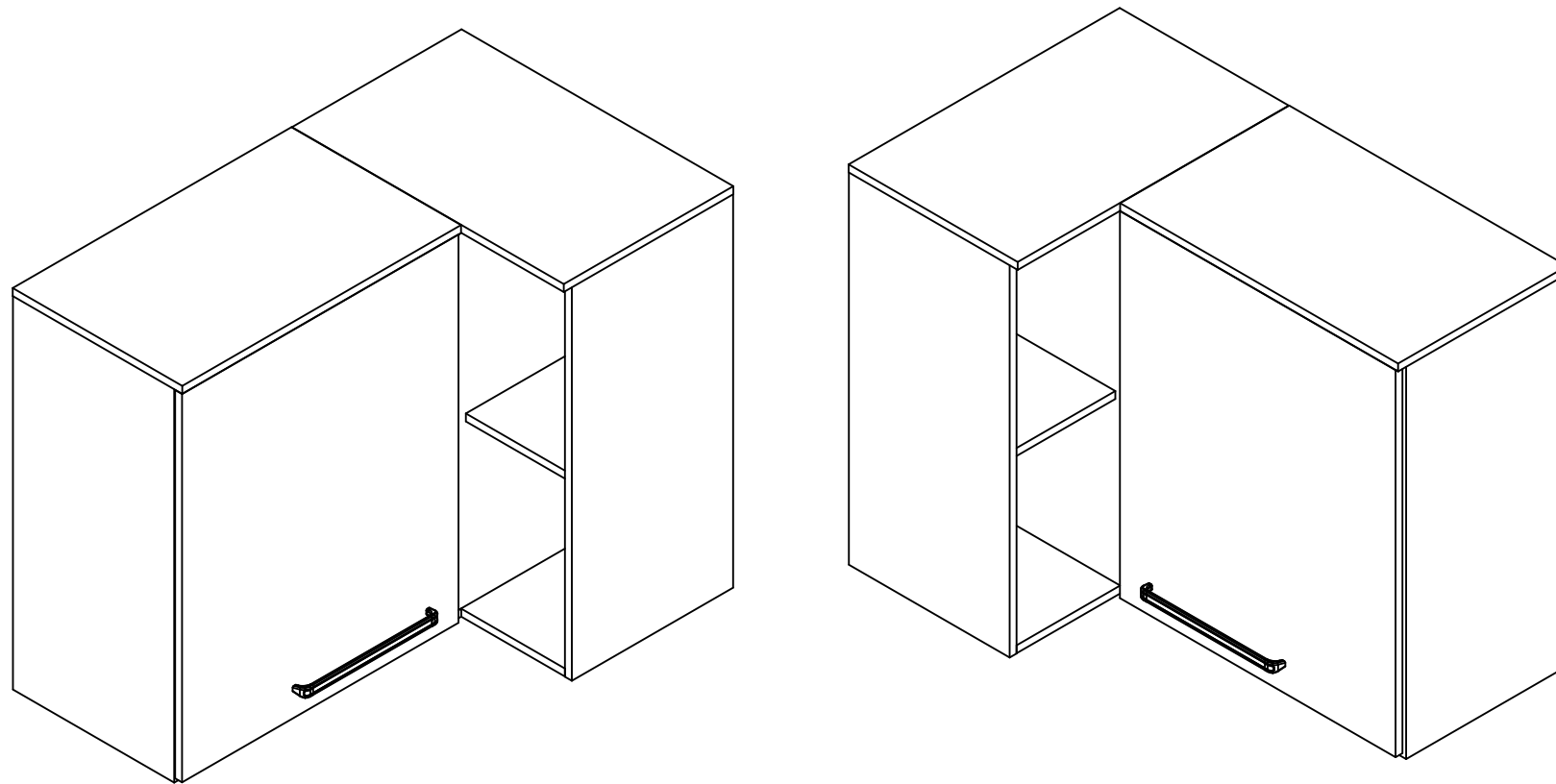

REF	DESC	M1	M2	M3	QTD
IS1615-01	LATERAL DIREITA/LADO DERECHO/RIGHT SIDE	740	350	15	1
IS1615-02	LATERAL ESQUERDA/LADO IZQUIERDO/SIDE	740	350	15	1
IS1615-03	BASE/BASE/BASE	608	350	15	1
IS1615-04	PRATELERA/ESTANTE/SHELF	225	340	15	1
IS1615-05	DIVISORIA/DIVISION/DIVISION	724	445	15	1
IS1615-07	PILASTRA EXTERNA/PILASTO EXTERNO	724	114	15	2
IS1615-08	CHAPEU/SOMBRERO/HAT	605	368	15	1
IS1615-11	PORTA /PUERTA/DOOR	540	730	15	1
IS1615-23	BASE MENOR/BASE/BASE	575	350	15	1
IS1615-24	PRATELERA/ESTANTE/SHELF	958	318	15	1
IS1615-28	CHAPEU/SOMBRERO/HAT	590	368	15	1
IS1615-61	COSTA/FONDO/BACK	748	600	3	1
IS1615-62	COSTA/FONDO/BACK	748	350	3	1
IS1615-63	COSTA/FONDO/BACK	748	245	3	1
IS1615-64	COSTA/FONDO/BACK	748	338	3	1

Lista de ferragens Lista de materiales Hardware list

A		CAVILHA Ø6X30 CLAVIJA Ø6X30 WOOD DOWEL Ø6X30	16
B		PARAFUSO CC 3,5X14 TORNILLO CC 3,5X14 SCREW CC 3,5X14	06
C		PARAFUSO CC 3,5X40 TORNILLO CC 3,5X40 SCREW CC 3,5X40	20
DB		DOBRADIÇA BISAGRA HINGE	02
F		PARAFUSO CF 4,5X50 TORNILLO CF 4,5X50 SCREW CF 4,5X50	03
Z		PARAFUSO CF 3,5X25 TORNILLO CF 3,5X25 SCREW CF 3,5X25	06
U		ADESIVO TAPA FURO ADHESIVO STICKER	06
M		PREGO 10X10 CLAVO 10X10 NAIL	55
V		COLA PEGAMENTO GLUE	01
PX		PUXADOR TIRADOR HANDLE	01
S		SUPORTE PRATELERA SOPORTE DE ESTANTE SHELF SUPPORT	06
X		FIXADOR COSTA FIJADOR DE ESPALDA BACK FIXER	05
G		PROTEÇÃO SUP CANTONEIRA PROTECCIÓN ANGLE BRACKET	03
H		SUPORTE FIXAÇÃO SOPORTE DE FIJACIÓN FIXING SUPPORT	03
I		BUCHA PLÁSTICA CASQUILLO BUSHING	03

FERRAMENTAS NECESSÁRIAS:  
HERRAMIENTAS NECESARIAS:  
NECESSARY TOOLS:



**"IMPORTANTE LER COM ATENÇÃO  
E GUARDAR PARA EVENTUAIS  
CONSULTAS".**

**"IMPORTANTE LEER CON ATENCIÓN Y GUARDAR PARA  
EVENTUALES CONSULTAS".**

**"IMPORTANT TO READ CAREFULLY AND SAVE FOR ANY  
QUERIES".**

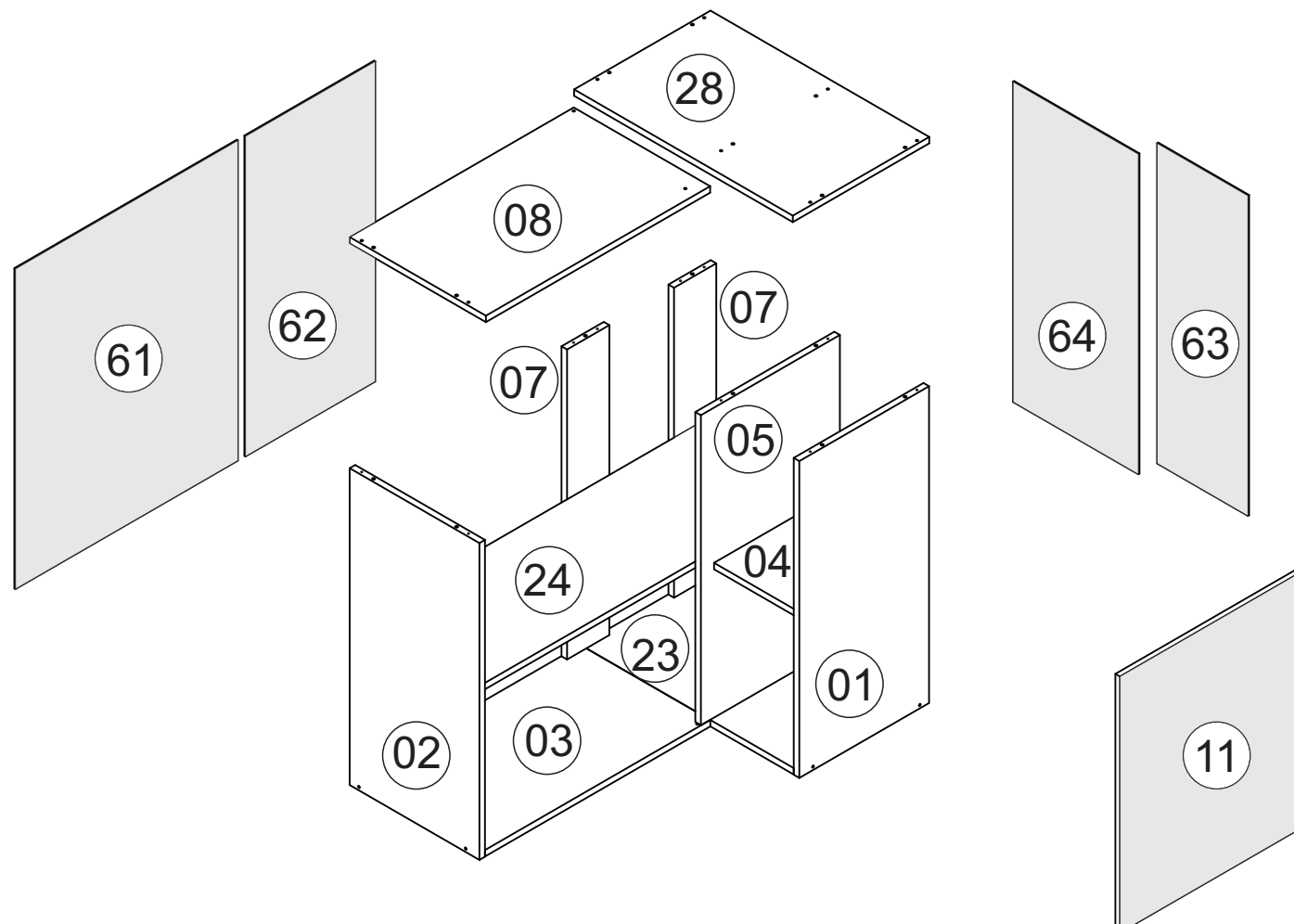



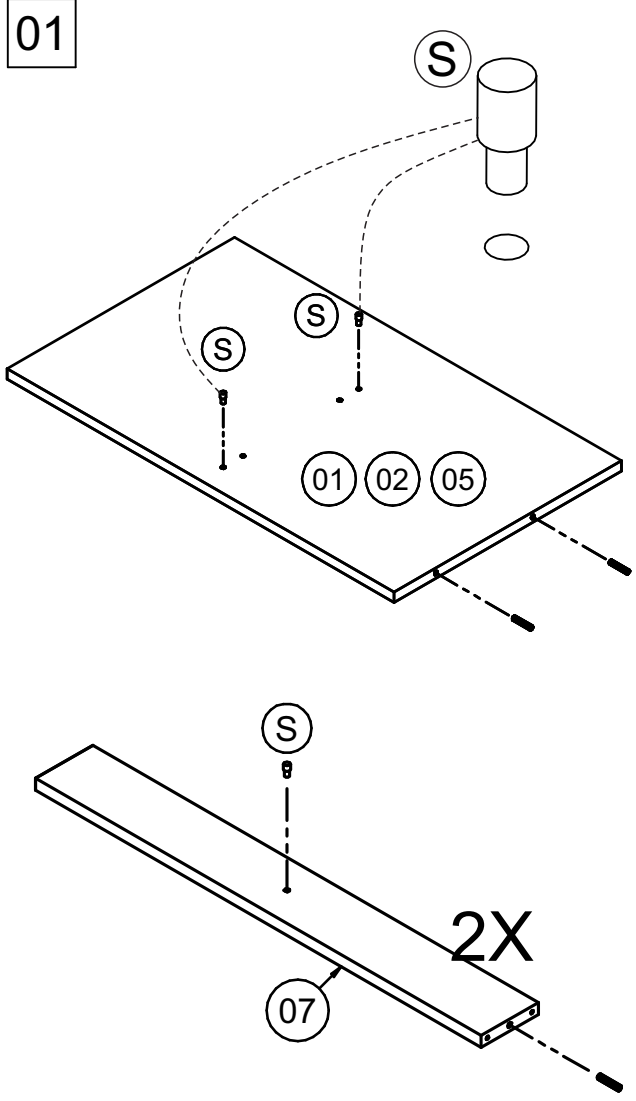

### LADO ESQUERDO

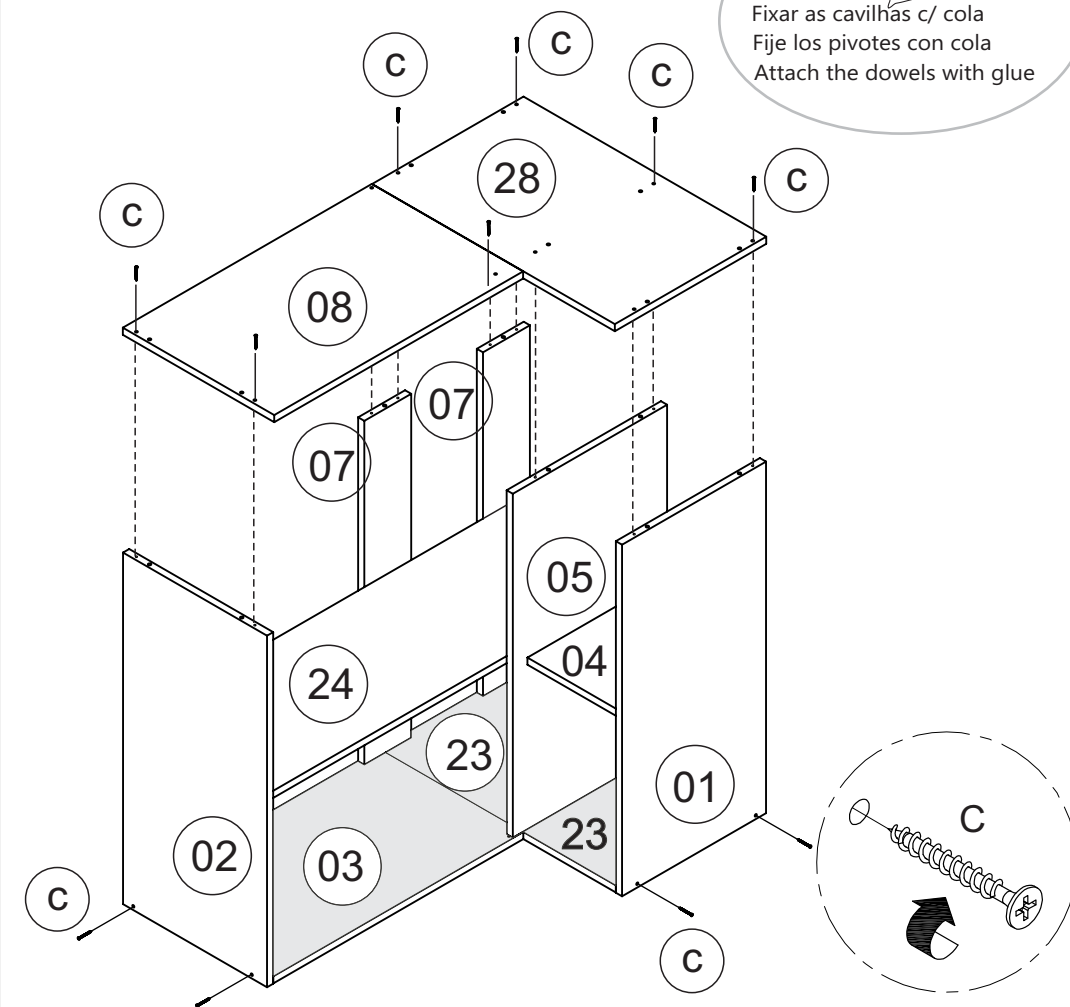

### 02 LADO DIREITO

Inserir Prateleira "24"

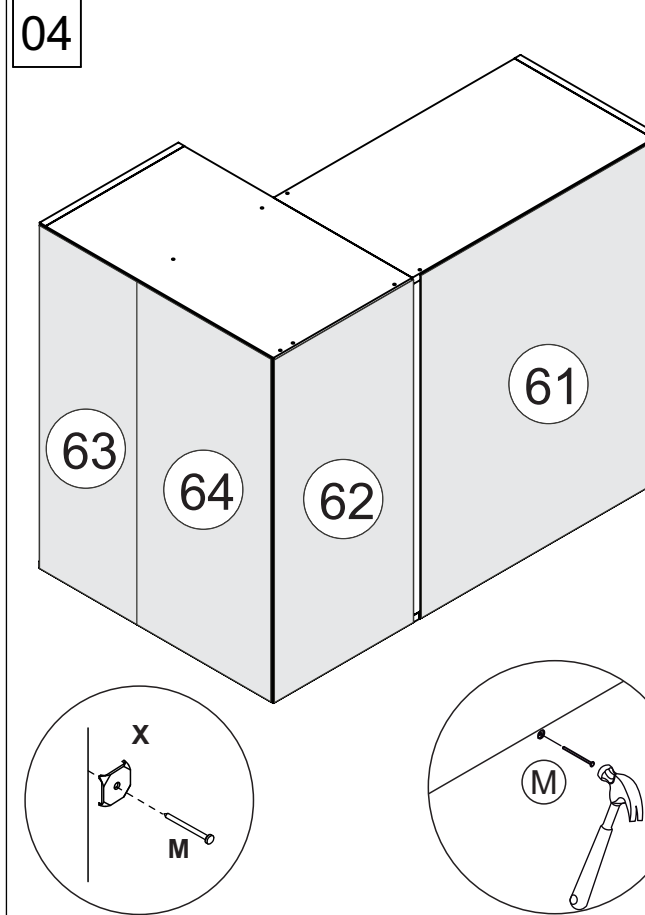
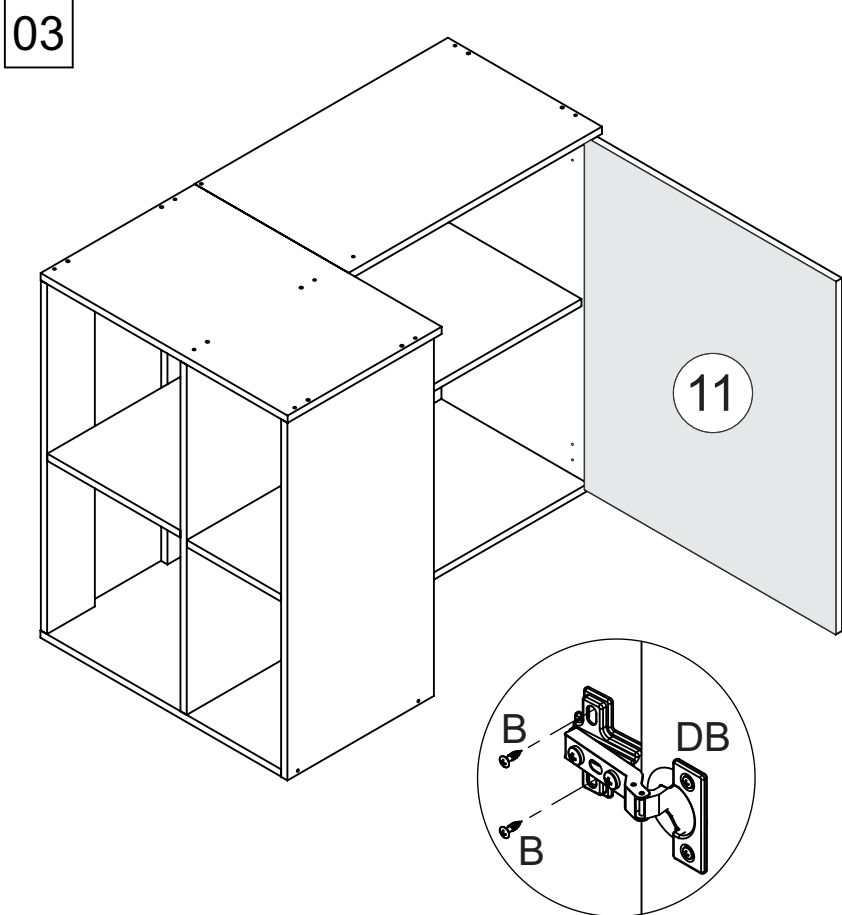
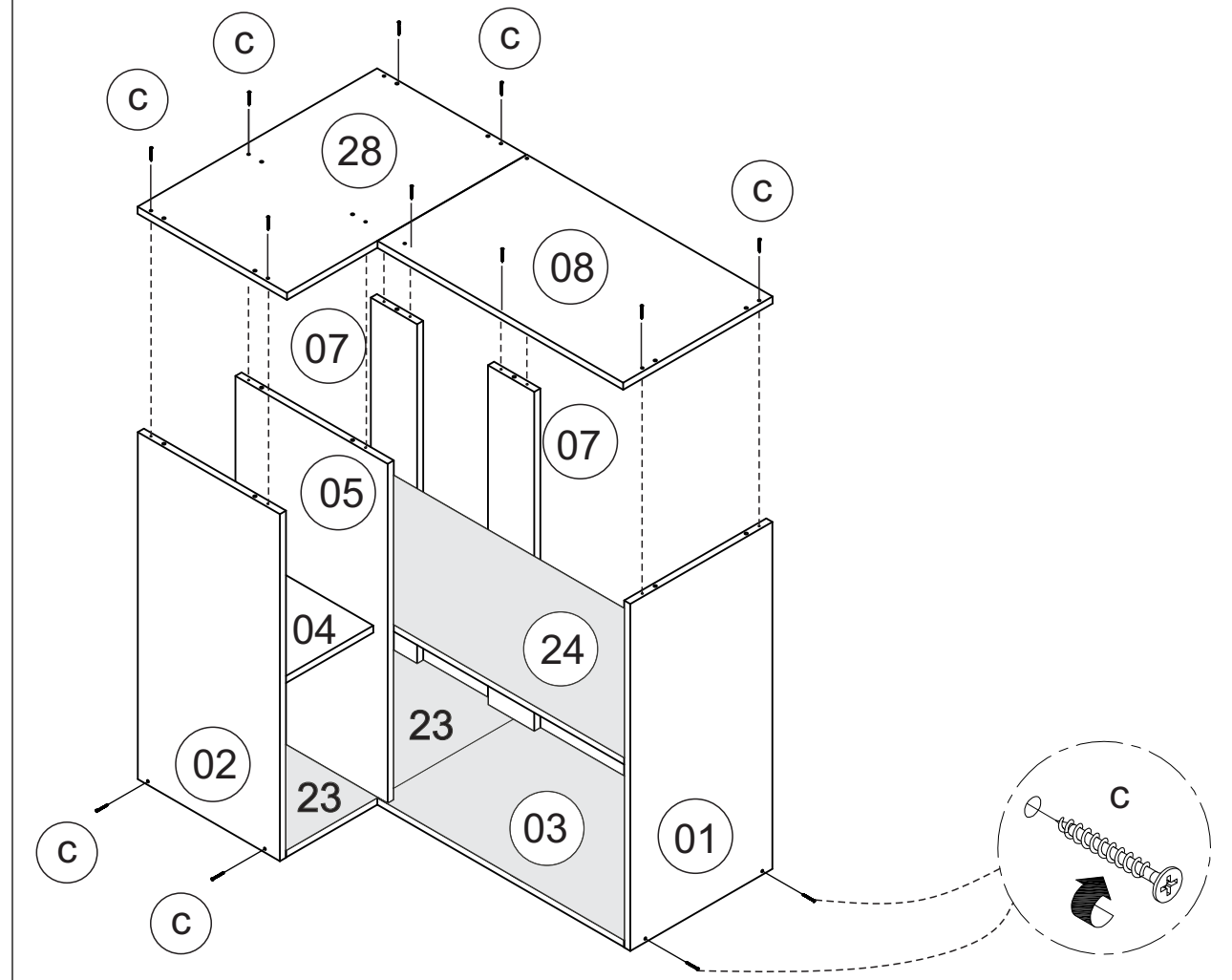

**05** Parafuso "Z" união de módulos  
Tornillo "Z" unión de módulos

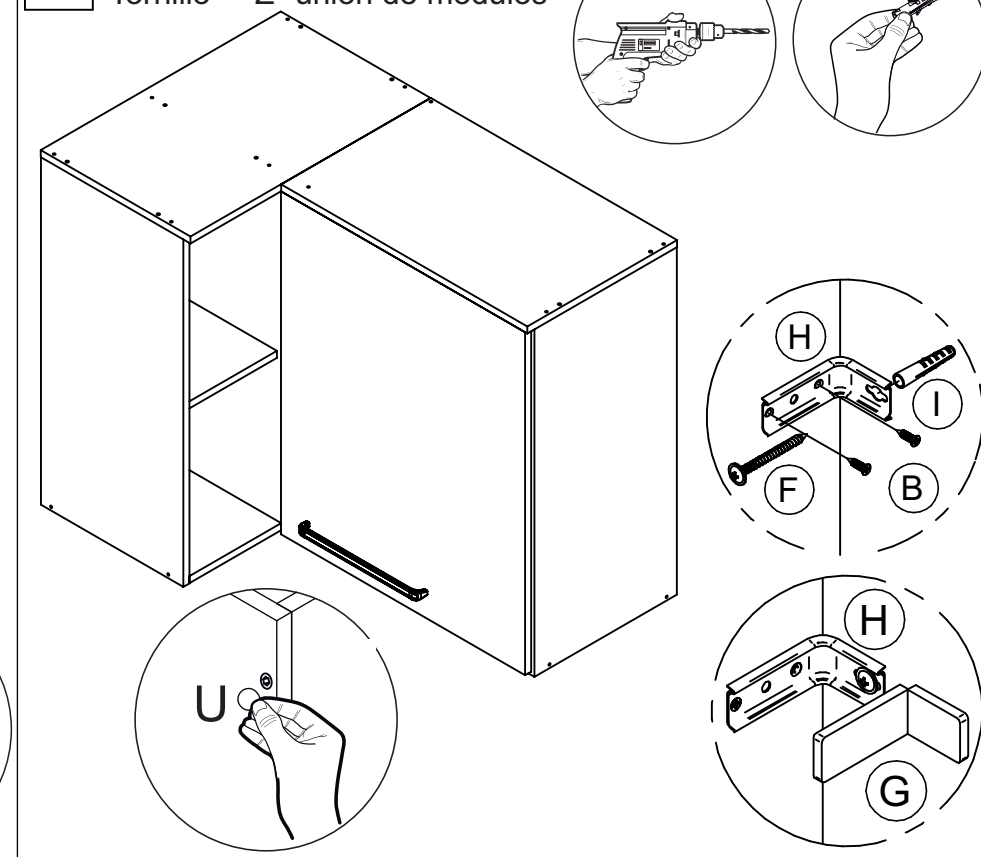

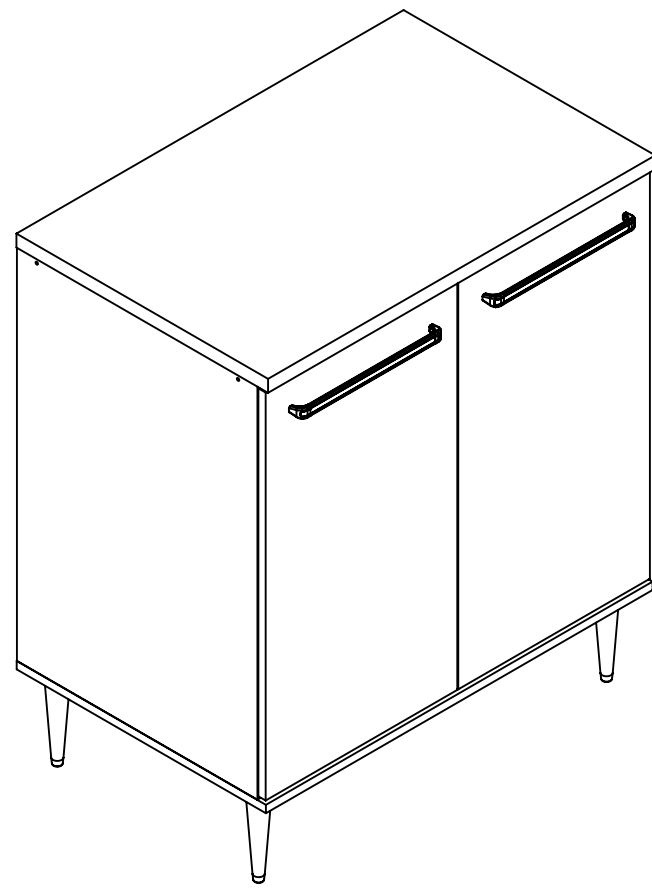

**Lista de ferragens  
Hardware list  
Lista de materiales**

<b>A</b>		CAVILHA Ø6X30 CLAVIJA Ø6X30 WOOD DOWEL Ø6X30	<b>16</b>
<b>B</b>		PARAFUSO CC 3,5X14 TORNILLO CC 3,5X14 SCREW CC 3,5X14	<b>02</b>
<b>C</b>		PARAFUSO CC 3,5X40 TORNILLO CC 3,5X40 SCREW CC 3,5X40	<b>08</b>
<b>DB</b>		DOBRADIÇA BISAGRA HINGE	<b>04</b>
<b>F</b>		PARAFUSO CF 4,5X50 TORNILLO CF 4,5X50 SCREW CF 4,5X50	<b>05</b>
<b>Z</b>		PARAFUSO CF 3,5X25 TORNILLO CF 3,5X25 SCREW CF 3,5X25	<b>11</b>
<b>U</b>		ADESIVO TAPA FURO ADHESIVO STICKER	<b>04</b>
<b>G</b>		PROTEÇÃO SUP CANTONEIRA PROTECCIÓN ANGLE BRACKET	<b>01</b>
<b>H</b>		SUPORTE FIXAÇÃO SOPORTE DE FIJACIÓN FIXING SUPPORT	<b>01</b>
<b>I</b>		BUCHA PLÁSTICA CASQUILLO BUSHING	<b>01</b>
<b>M</b>		PREGO 10X10 CLAVO 10X10 NAIL	<b>45</b>
<b>V</b>		COLA PEGAMENTO GLUE	<b>01</b>
<b>PX</b>		PUXADOR TIRADOR HANDLE	<b>02</b>
<b>PE</b>		PÉ PIE FOOT	<b>04</b>
<b>X</b>		FIXADOR COSTA FIJADOR DE ESPALDA BACK FIXER	<b>05</b>

**Lista de peças / Parts lists / Lista de piezas**

REF	DESC	COMP	LARG	ESP	QTD.
IS1501-01	LATERAL DIREITA/LADO DERECHO/RIGHT SIDE	740	497	15	1
IS1501-02	LATERAL ESQUERDA/LADO IZQUIERDO/LEFT SIDE	740	497	15	1
IS1501-03	BASE/BASE/BASE	799	515	15	1
IS1501-04	PRATELEIRA/ESTANTE/SHELF	768	350	15	1
IS1501-06	TRAVESSA FRONTAL/TRAVESAN~I/LONG PLATE	768	60	15	1
IS1501-10	TAMPO/TAPA/TOP	800	520	25	1
IS1501-12	PORTA/PUERTA/DOOR	396	730	15	2
IS1501-26	TRAVESSA TRASERA/TRAVESAN~I/LONG PLATE	768	60	15	1
IS1501-61	COSTA/FONDO/BACK	375	790	3	2

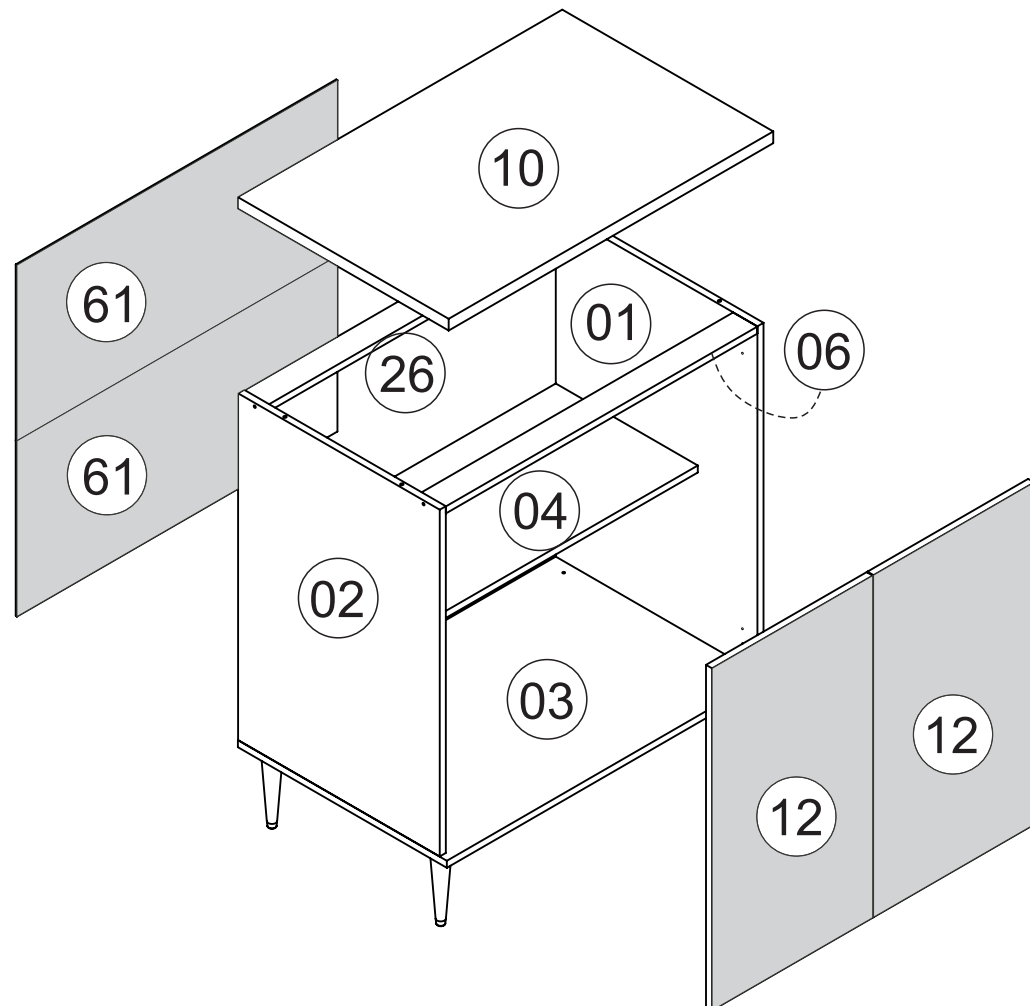

FERRAMENTAS NECESSÁRIAS:  
HERRAMIENTAS NECESARIAS:  
NECESSARY TOOLS:



**"IMPORTANTE LER COM ATENÇÃO  
E GUARDAR PARA EVENTUAIS  
CONSULTAS".**

"IMPORTANTE LEER CON ATENCIÓN Y GUARDAR PARA  
EVENTUALES CONSULTAS".

"IMPORTANT TO READ CAREFULLY AND SAVE FOR ANY  
QUERIES".



01

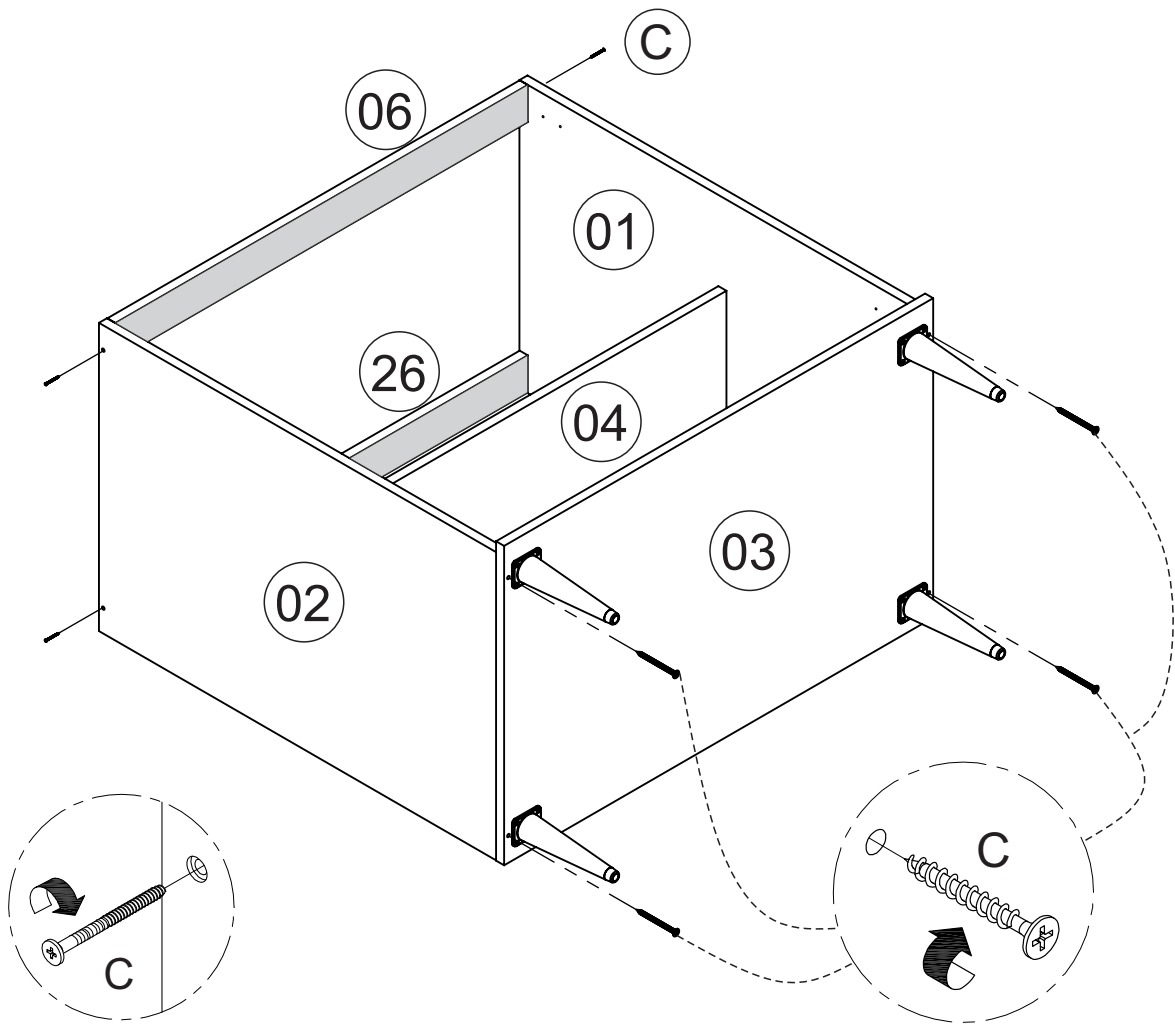

Fixar as cavilhas c/ cola  
Fije los pivotes con cola  
Attach the dowels with glue

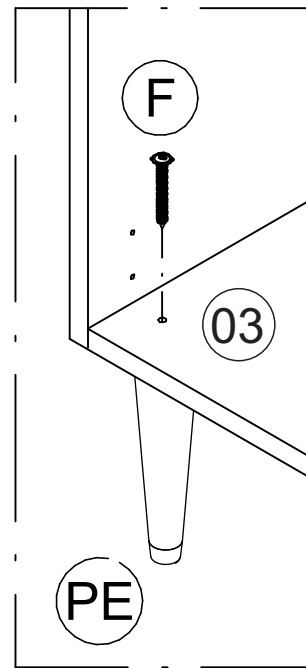

02

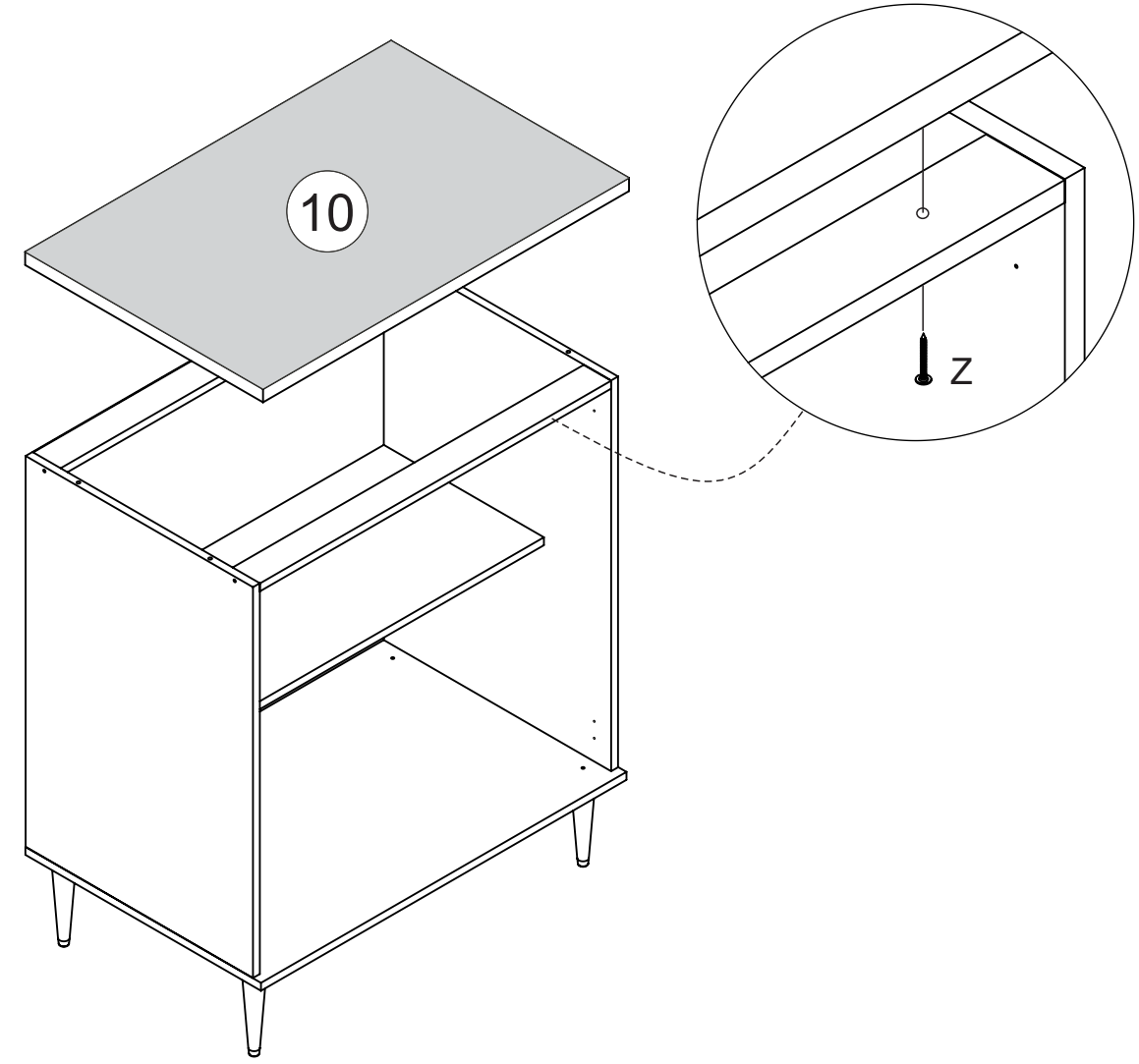

03

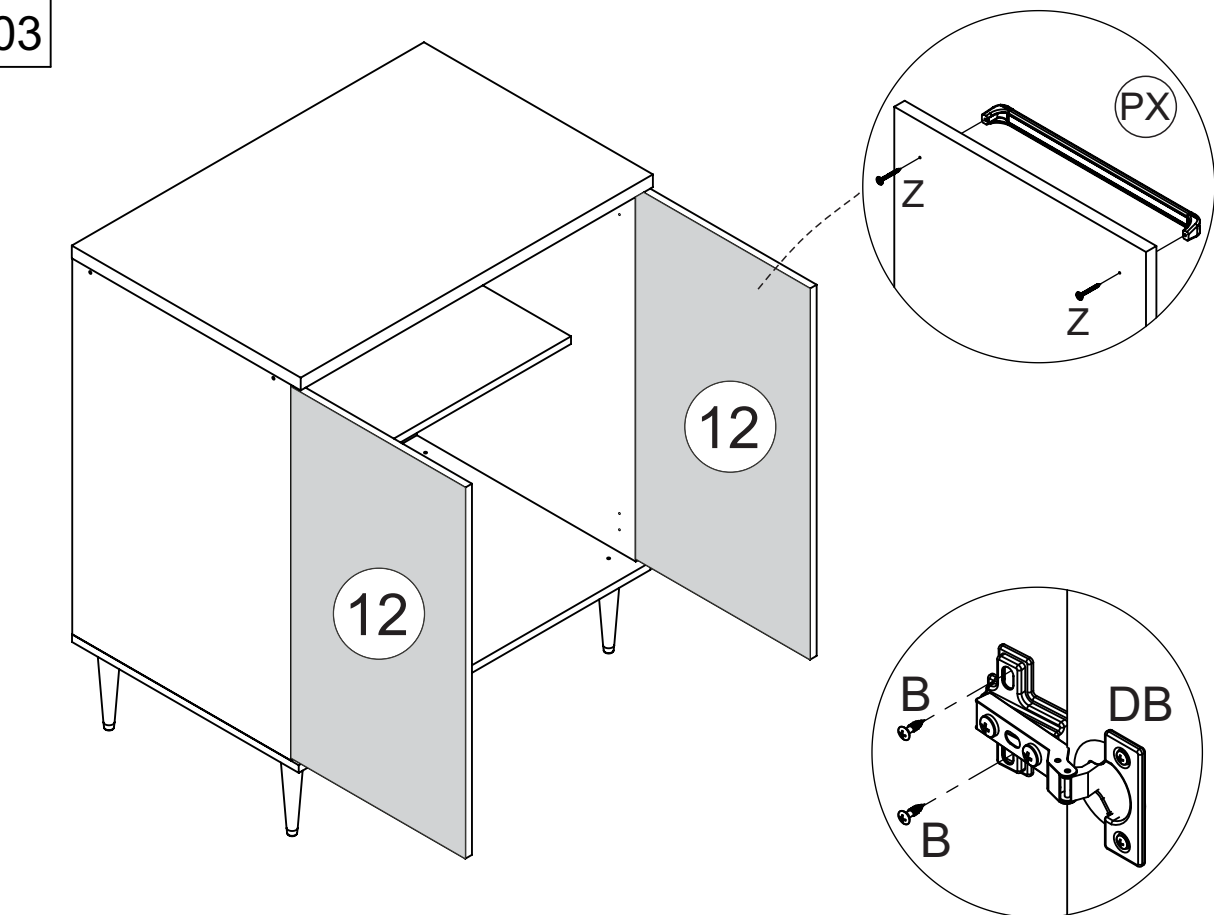

04

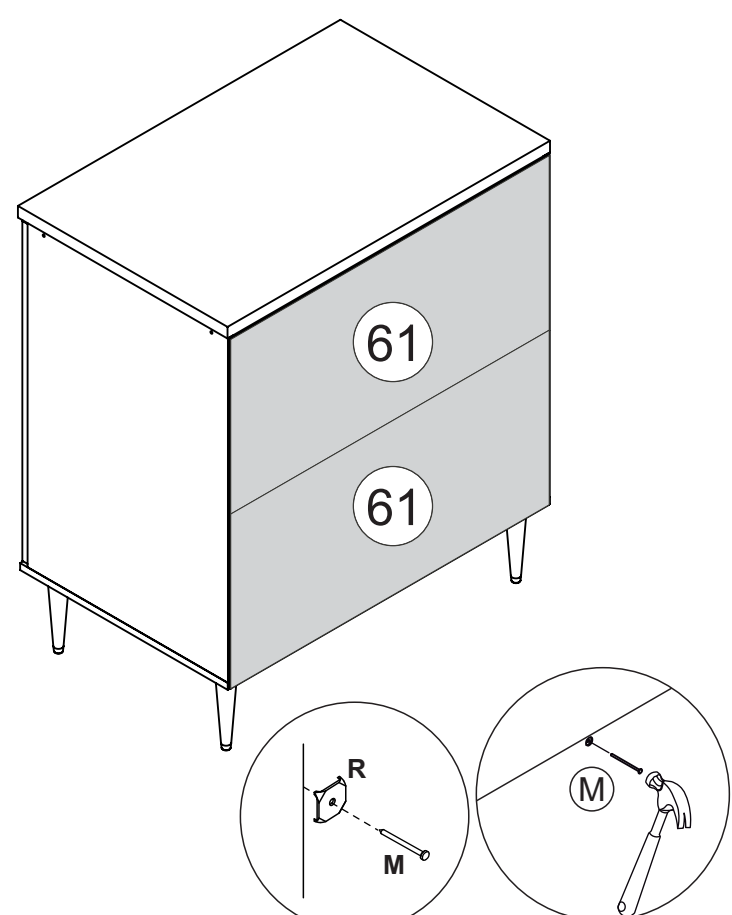

05

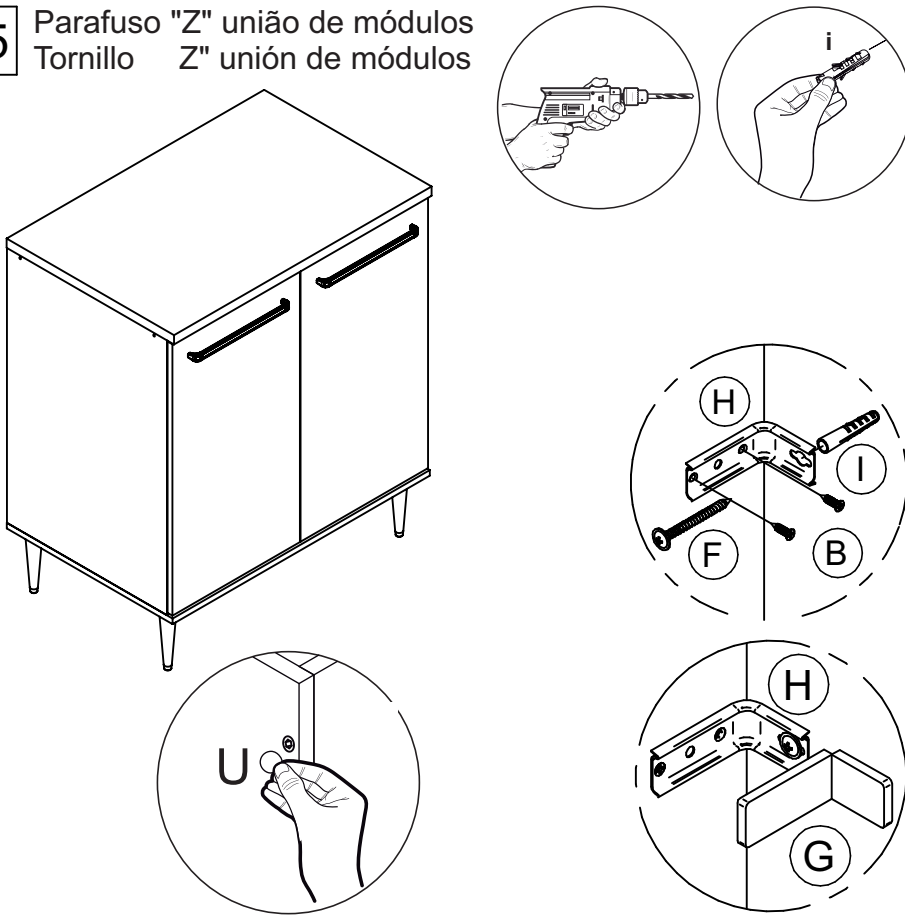

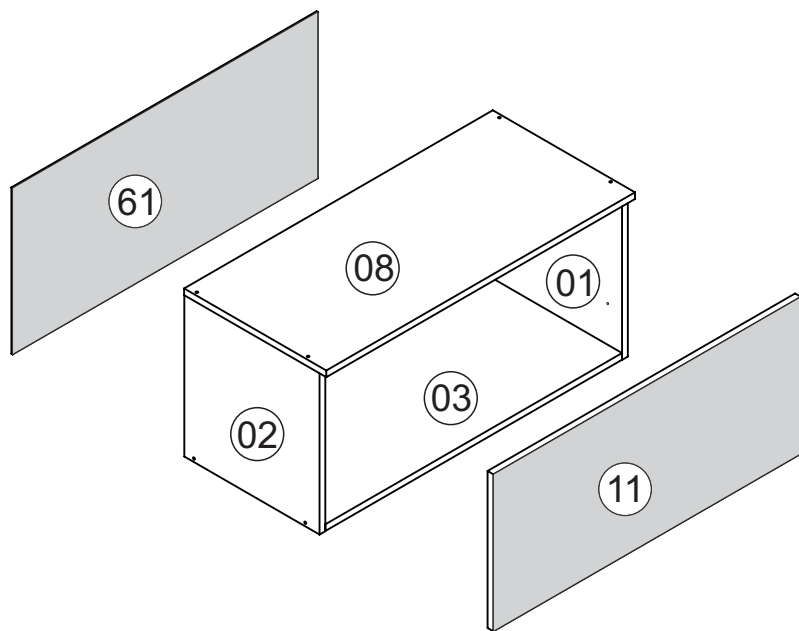
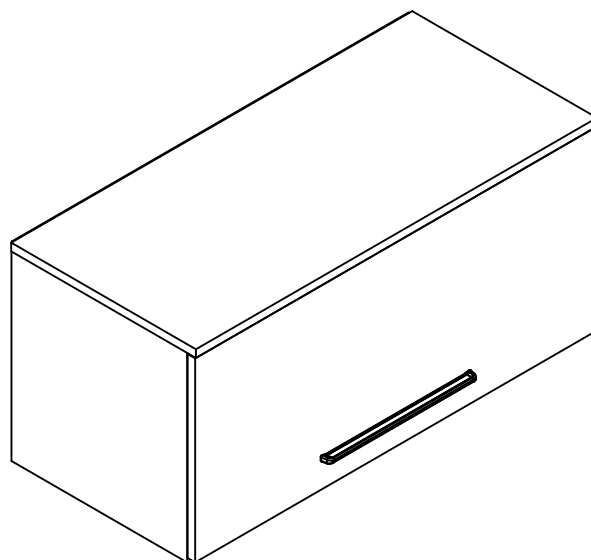

A		CAVILHA Ø6X30 CLAVIJA Ø6X30 WOOD DOWEL Ø6X30	08
B		PARAFUSO CC 4X14 TORNILLO CC 4X14 SCREW CC 4X14	02
C		PARAFUSO CC 4X40 TORNILLO CC 4X40 SCREW CC 4X40	08
DB		DOBRADIÇA BISAGRA HINGE	02
F		PARAFUSO CF 4,5X50 TORNILLO CF 4,5X50 SCREW CF 4,5X50	01
M		PREGO 10X10 CLAVO 10X10 NAIL	25
U		ADESIVO TAPA FURO ADHESIVO STICKER	04
G		PROTEÇÃO SUP CANTONEIRA PROTECCIÓN ANGLE BRACKET	01
H		SUPOORTE FIXAÇÃO SOPORTE DE FIJACIÓN FIXING SUPPORT	01
I		BUCHA PLÁSTICA CASQUILLO BUSHING	01
Z		PARAFUSO CC 4X30 TORNILLO CC 4X30 SCREW CC 4X30	05
PX		PUXADOR TIRADOR HANDLE	01
P		PISTAO PISTON PISTON	01

FERRAMENTAS NECESSÁRIAS:  
HERRAMIENTAS NECESARIAS:  
NECESSARY TOOLS:



**"IMPORTANTE LER COM ATENÇÃO  
E GUARDAR PARA EVENTUAIS  
CONSULTAS".**

**"IMPORTANTE LEER CON ATENCIÓN Y GUARDAR PARA  
EVENTUALES CONSULTAS".**

**"IMPORTANT TO READ CAREFULLY AND SAVE FOR ANY  
QUERIES".**

Lista de peças / Parts lists / Lista de piezas

REF	DESC	COMP	LARG	ESP	QTD.
IS1611-01	LATERAL DIREITA/LADO DERECHO/RIGHT SIDE	362	350	15	1
IS1611-02	LATERAL ESQUERDA/LADO IZQUIERDO/LEFT SIDE	362	350	15	1
IS1611-03	BASE/BASE/BASE	768	350	15	1
IS1611-08	CHAPEU/SOMBREIRO/HAT	800	368	15	1
IS1611-11	PORTA/PUERTA/DOOR	796	352	15	1
IS1611-61	COSTA/FONDO/BACK	373	790	3	1

