

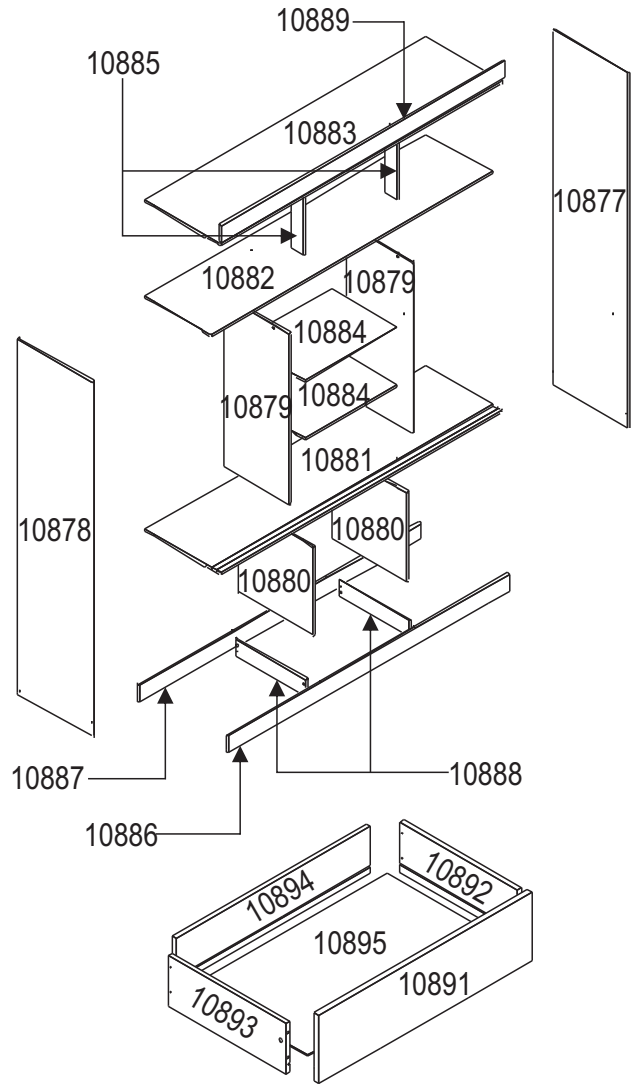

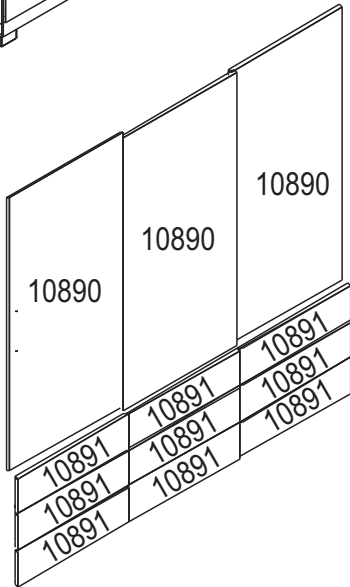

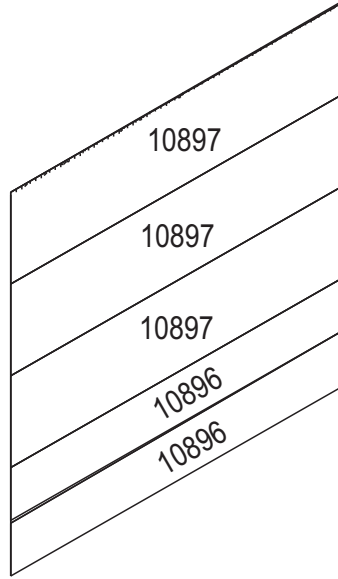

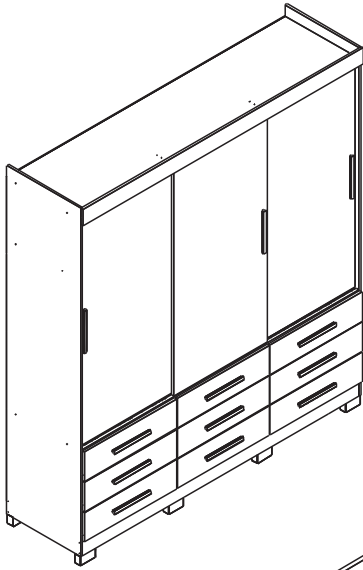



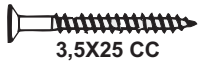

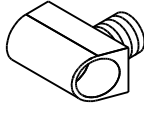
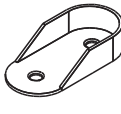

AxLxP 2130x1930x528 MM

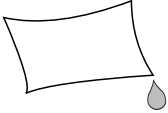
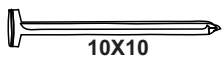

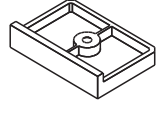
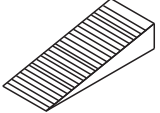
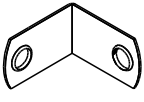

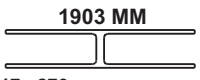
CÓD	DESCRIÇÃO	DIMENSÕES	QTD	VOL
10877	LATERAL DIREITA	510x2.080x12	01	1/3
10878	LATERAL ESQUERDA	510x2.080x12	01	1/3
10879	LATERAL INTERNA	445x1.008x12	02	1/3
10880	LATERAL DO GAVETEIRO	510x521x12	02	1/3
10881	BASE INFERIOR	510x1.905x15	01	2/3
10882	BASE SUPERIOR	510x1.905x15	01	2/3
10883	BASE DO MALHRO	445x1.905x12	01	2/3
10884	PRATELEIRA	445x627x12	02	1/3
10885	BATENTE	80x350x12	02	1/3
10886	RODAPÉ	97x1.905x15	01	2/3
10887	RODAPÉ TRASEIRO	97x1.905x15	01	2/3

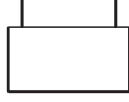
CÓD	DESCRIÇÃO	DIMENSÕES	QTD	VOL
10888	TRAVAMENTO DE RODAPÉ	97x480x12	02	1/3
10889	MOLDURA SUPERIOR	97x1.900x15	01	2/3
10890	PORTA	646x1.355x15	03	3/3
10891	FRENTE DE GAVETA	176x635x15	09	3/3
10892	LATERAL DIREITA DE GAVETA	130x350x12	09	1/3
10893	LATERAL ESQUERDA DE GAVETA	130x350x12	09	1/3
10894	CONTRA-FUNDO	120x577x12	09	3/3
10895	FUNDO DE GAVETA	350x587x03	09	2/3
10896	FUNDO DO GAVETEIRO	274x1.927x03	02	2/3
10897	FUNDOS SUPERIOR	461x1.927x03	03	2/3

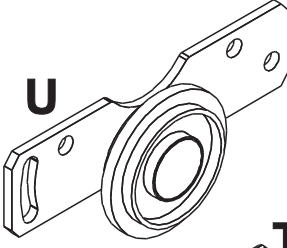
<p>A  X40</p> <p>016600040</p>	<p>B  X86</p> <p>016600037</p>	<p>C  X134</p> <p>016600032</p>	<p>D  X24</p> <p>016600041</p>
<p>E  X32</p> <p>016600059</p>	<p>F  X17</p> <p>016600089</p>	<p>G  X04</p> <p>010000022</p>	<p>H  X48</p> <p>016600007</p>
<p>I  X01</p> <p>016600069</p>	<p>J  X100</p> <p>016600063</p>	<p>K  X12</p> <p>016600015</p>	<p>L  X06</p> <p>016600016</p>
<p>M  X01</p> <p>016600010</p>	<p>N  X07</p> <p>016600006</p>	<p>O  X09</p> <p>011100011</p>	<p>P  X12</p> <p>014705116 - 238;258 014705115 - 276 014705136 - 278</p>
<p>Q  X03</p> <p>014005417 - 276 014005418 - 238;258 014005801 - 278</p>	<p>R  X02</p> <p>010204920</p>	<p>S  X02</p> <p>014204634 - 238;258 014204635 - 276 014204650 - 278</p>	

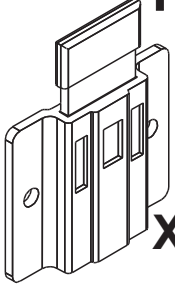
U  **X02**

T  **X02**

D  **X10**

010000019

X03



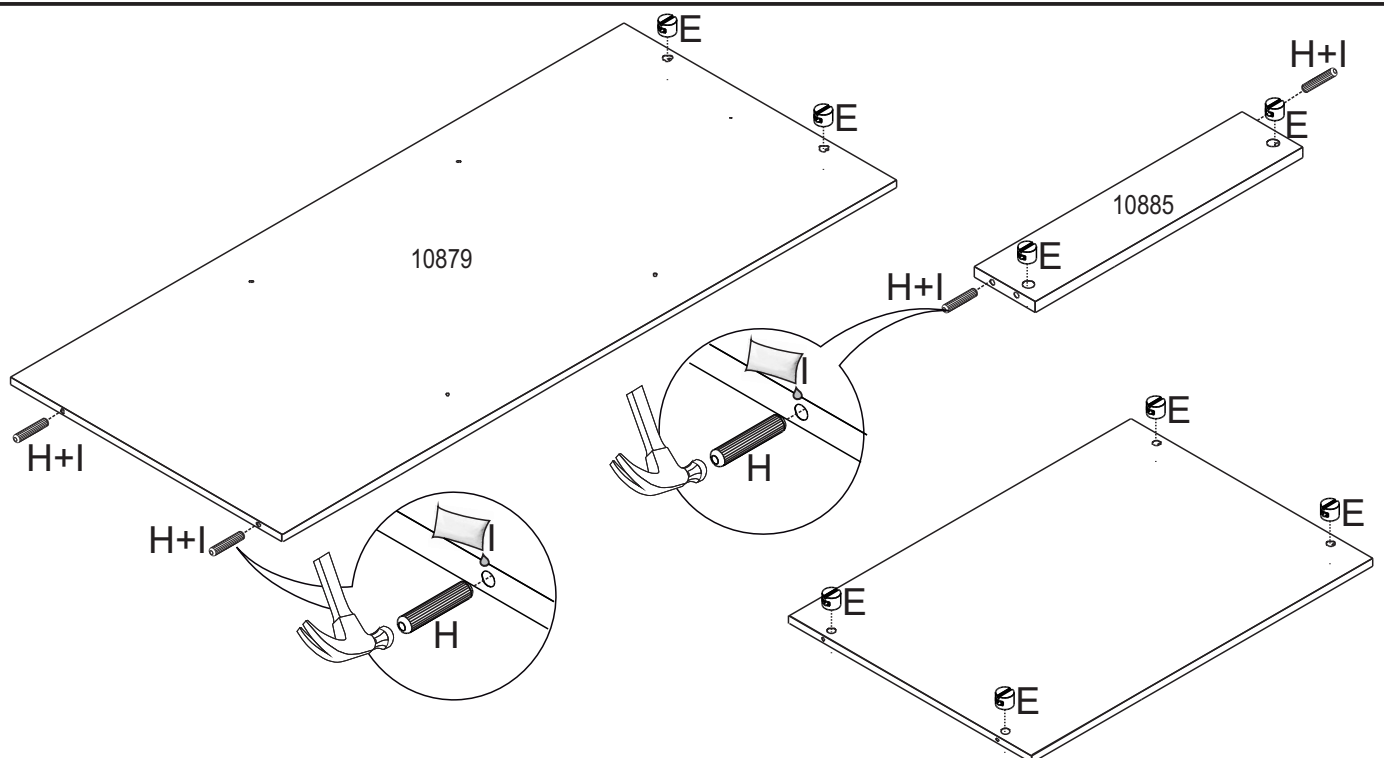
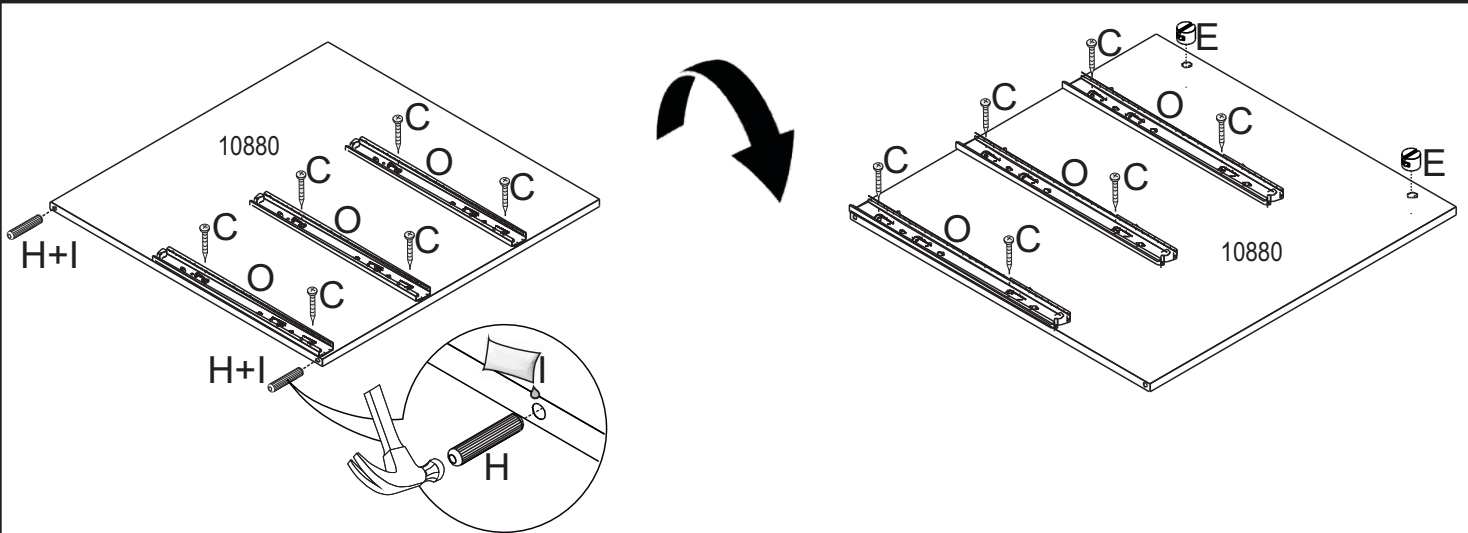
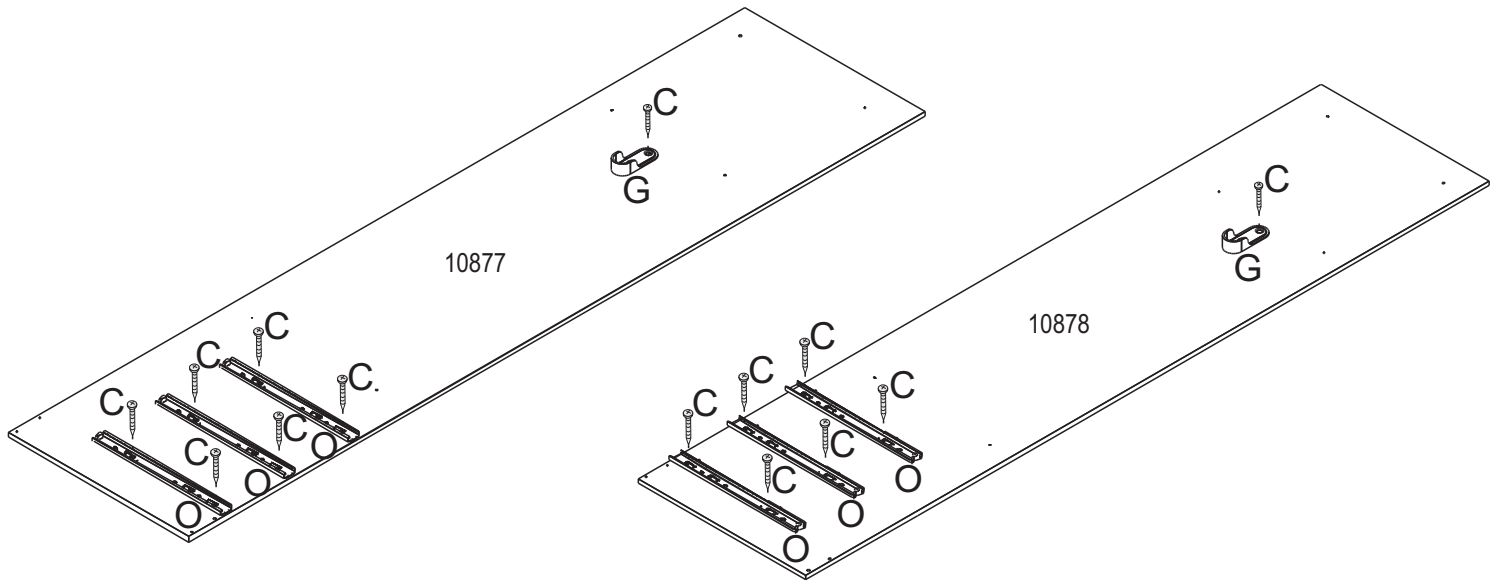

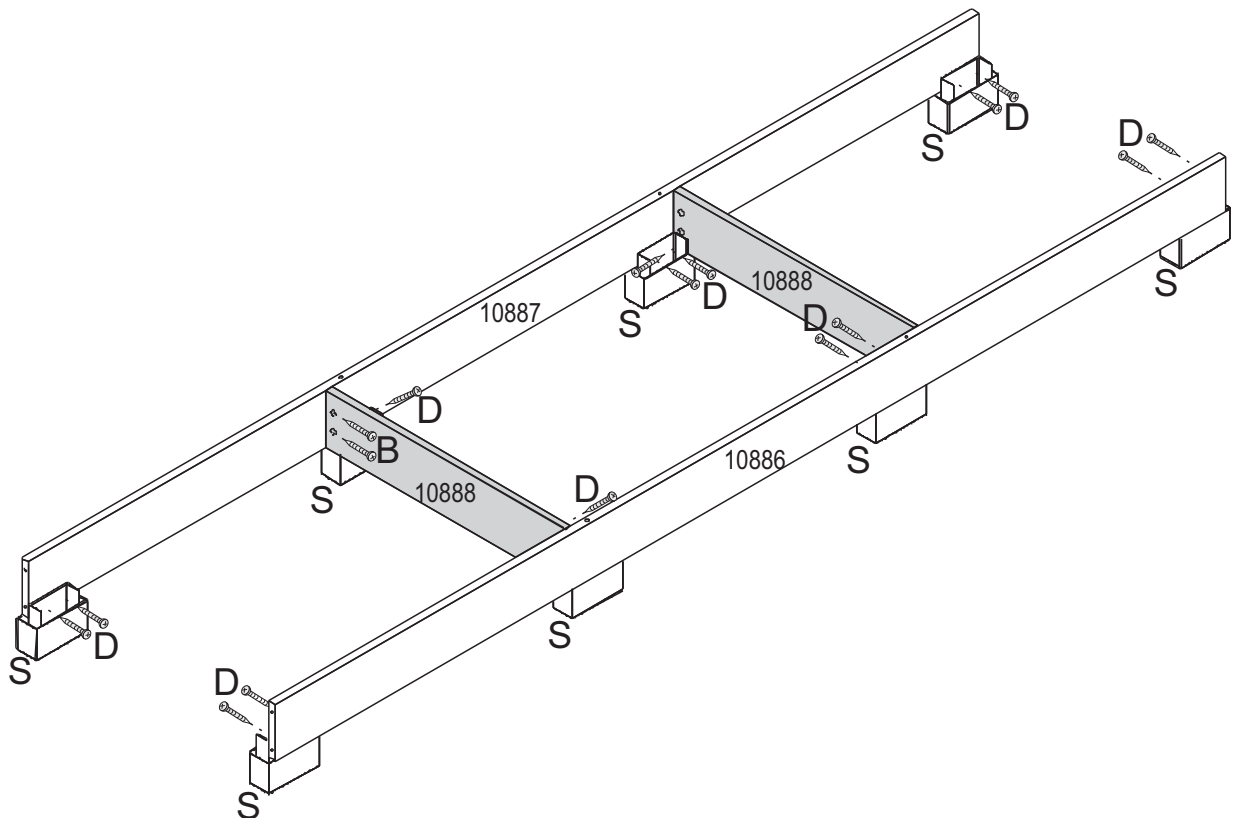
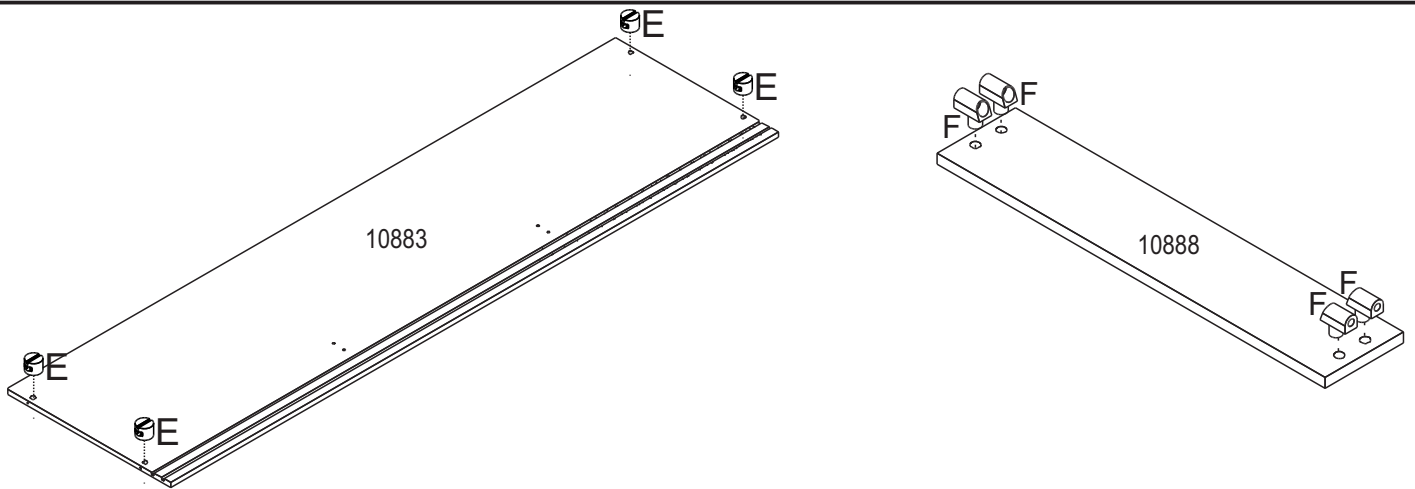
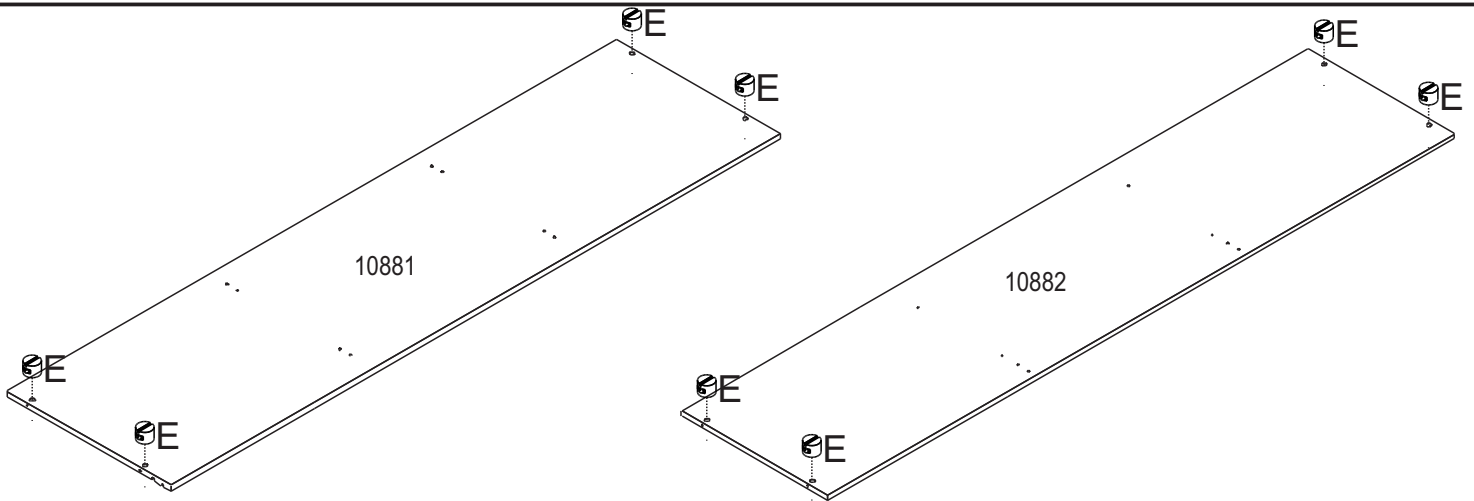

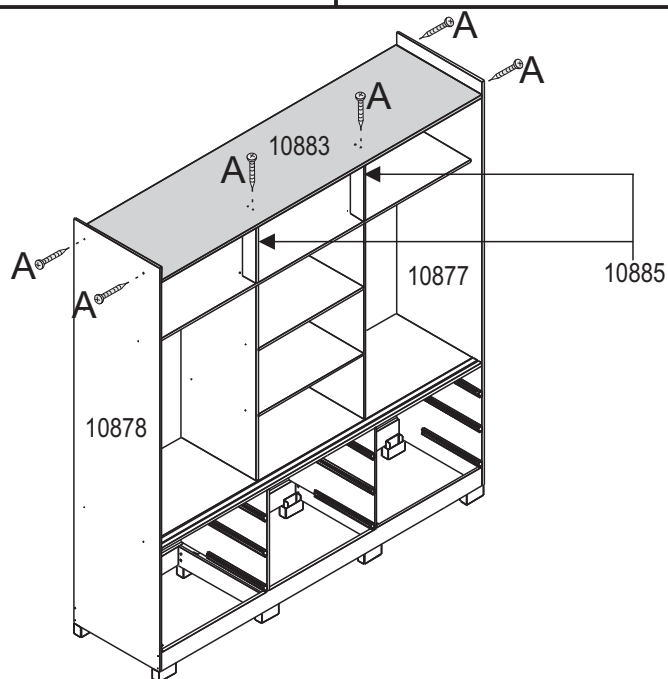
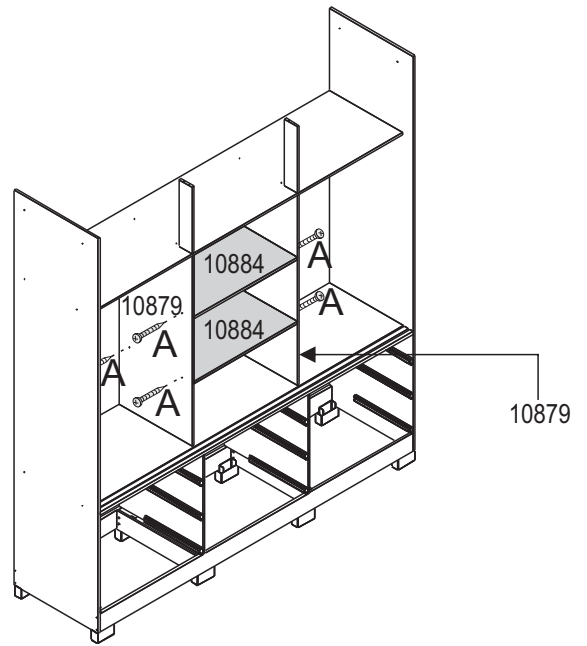
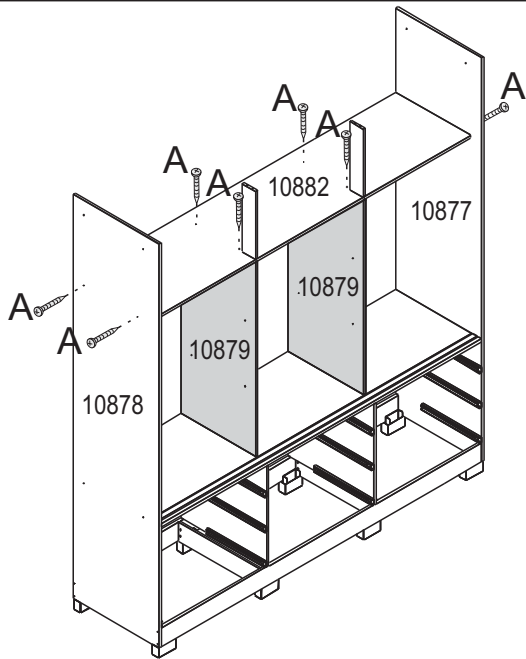
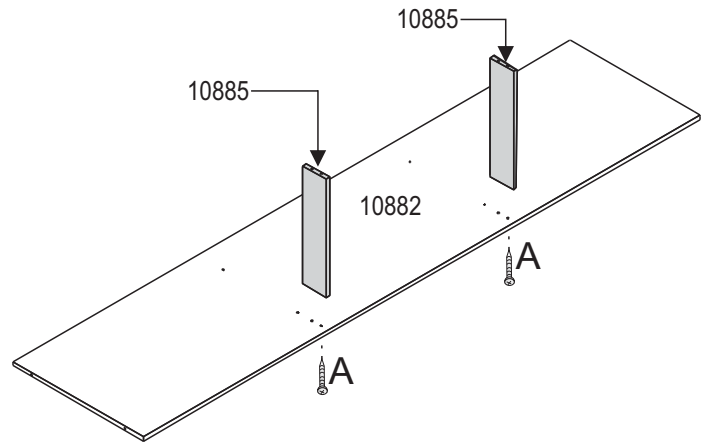
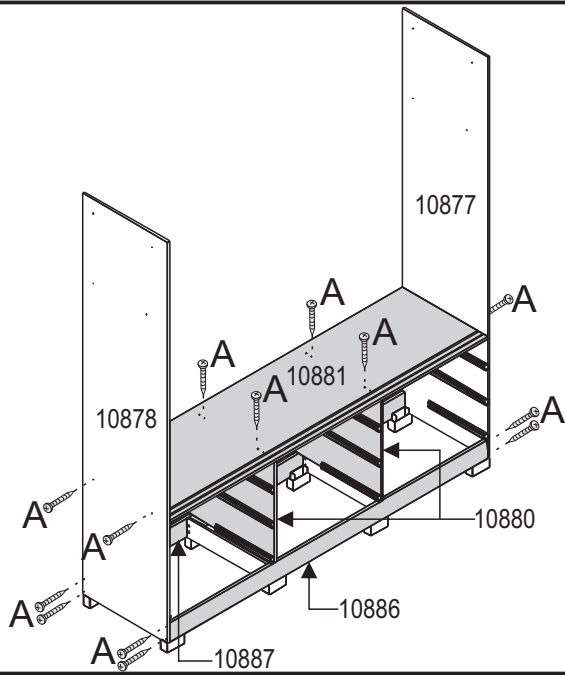

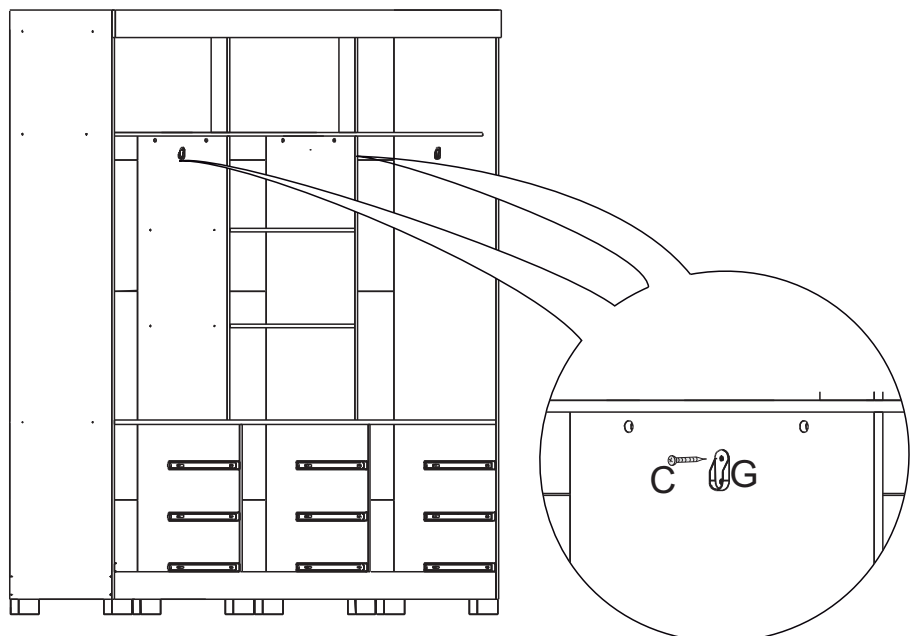
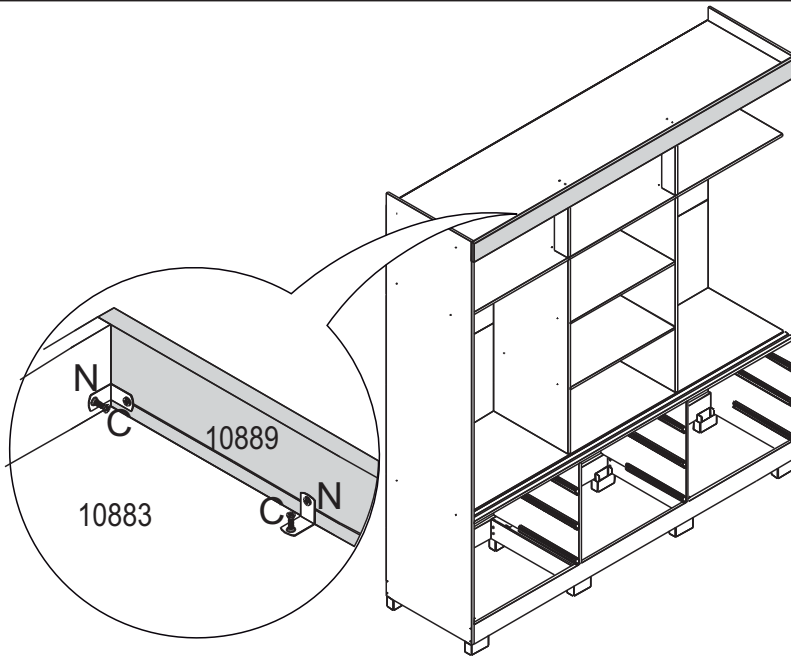
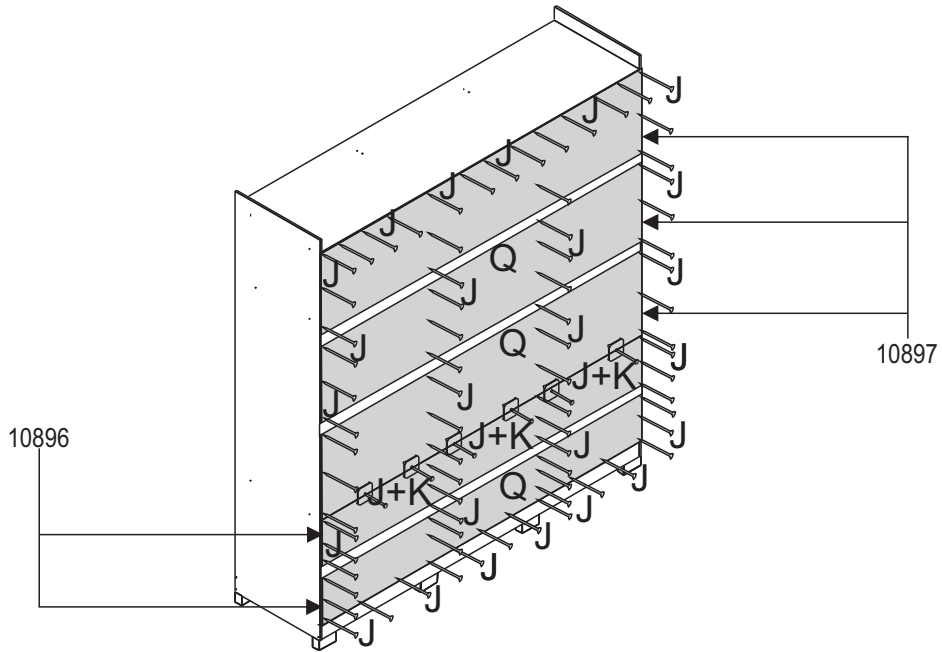

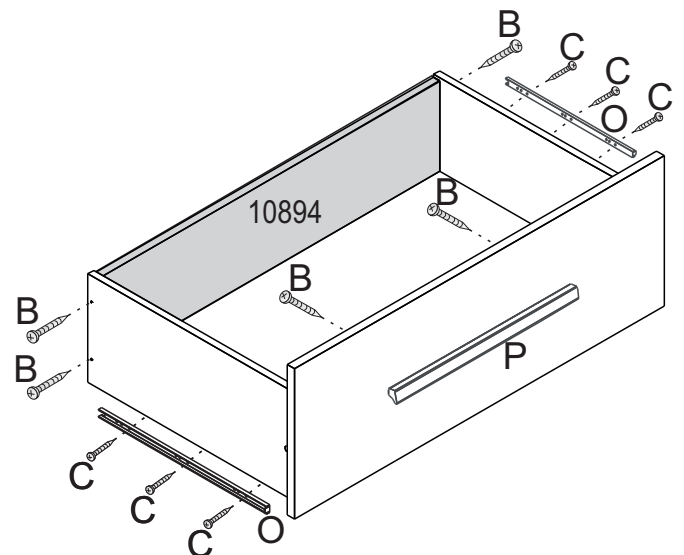
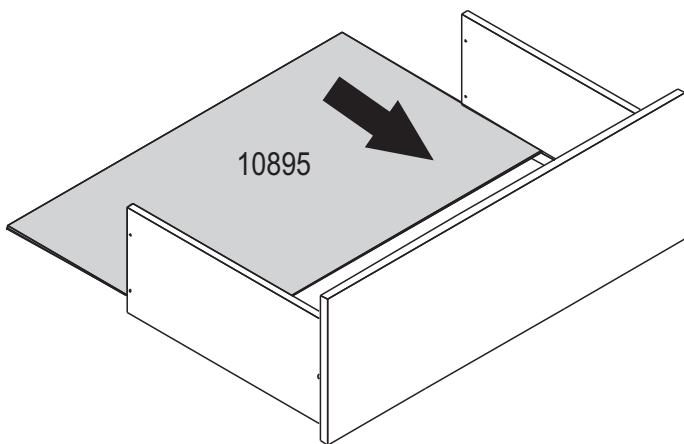
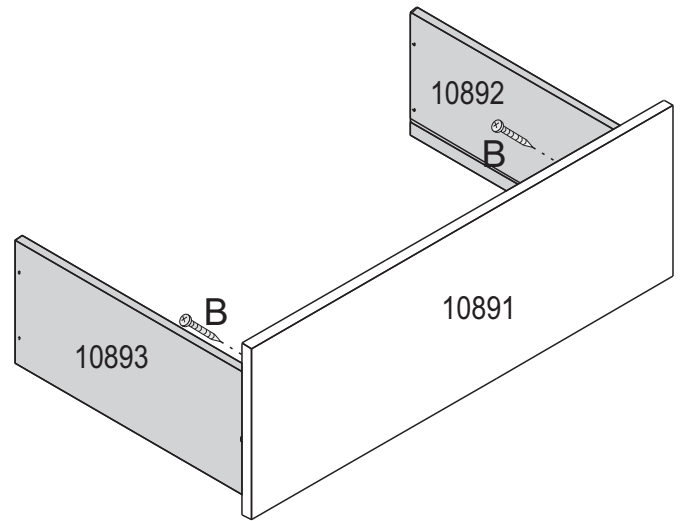
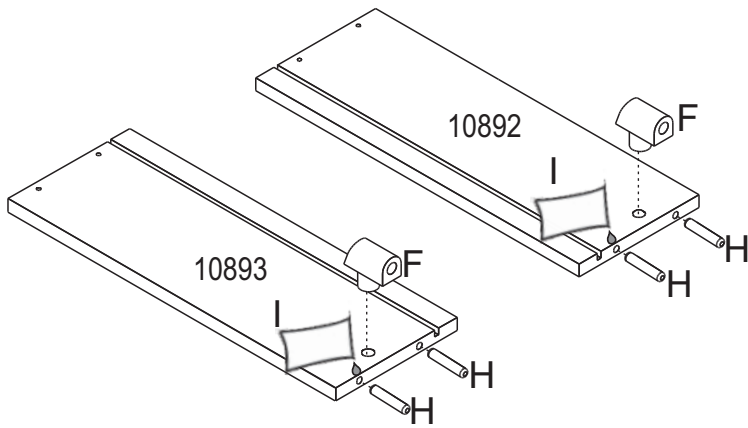
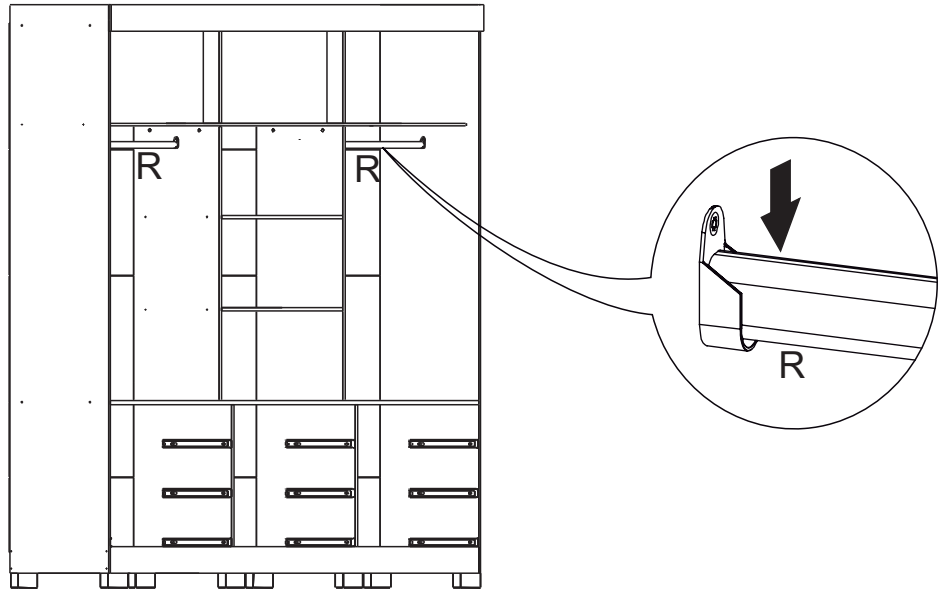

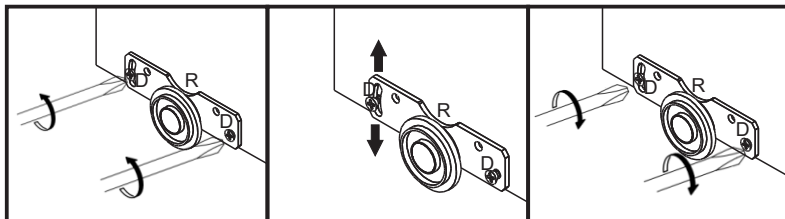
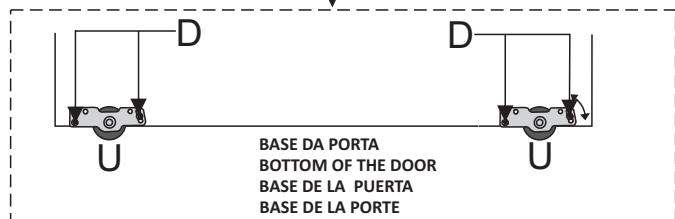
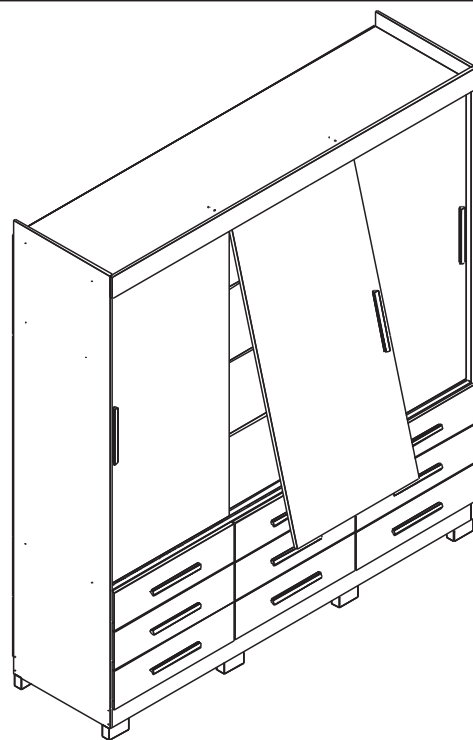
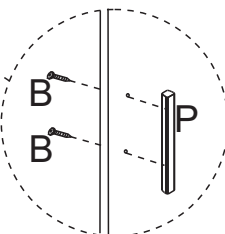
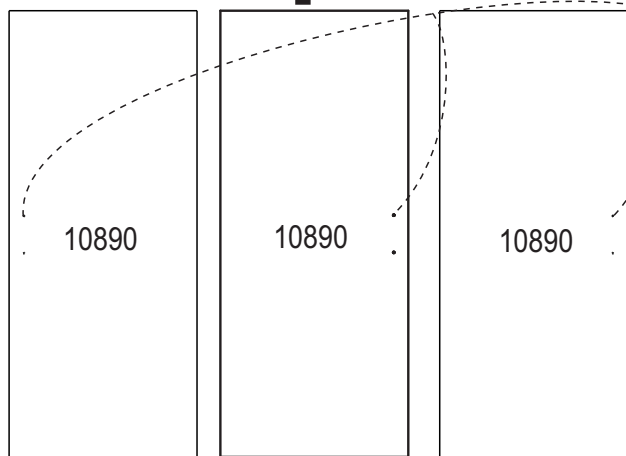
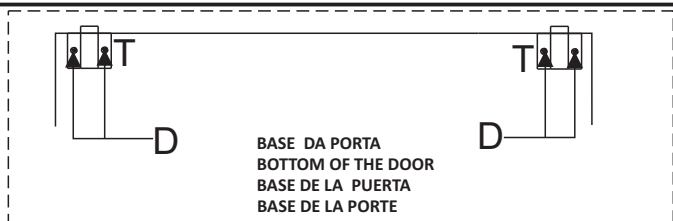
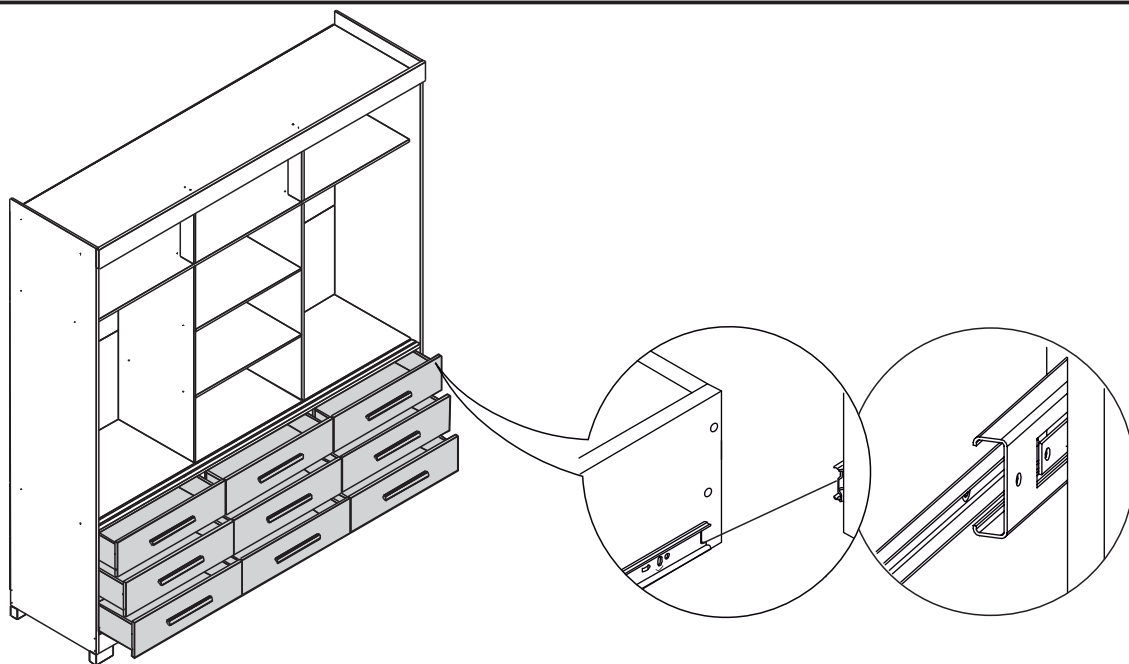

peça piece pieza

- * Em caso de problemas técnicos com o móvel, favor informar o número de lote, número da op e data de fabricação, identificados nas etiquetas das caixas, para o rastreamento interno do produto e solução do problema.
- * In case of technical problems with the product, please identify lot number, OP number and production date, located on the ticket boxes for Internal tracking and solution of the problem
- * En caso de problemas tecnicos con el mueble, por favor informar el numero del lote, numero de la OP y fecha de producción, identificados en las etiquetas de las cajas, para el rastreamento interno del producto y solución del problema.

