

GUARDA - ROUPAS SOHO 02 PORTA
WARDROBE SOHO 02 DOOR
PLACARD SOHO 02 PUERTA

FKEX-910

01/03/24 Rev. 01

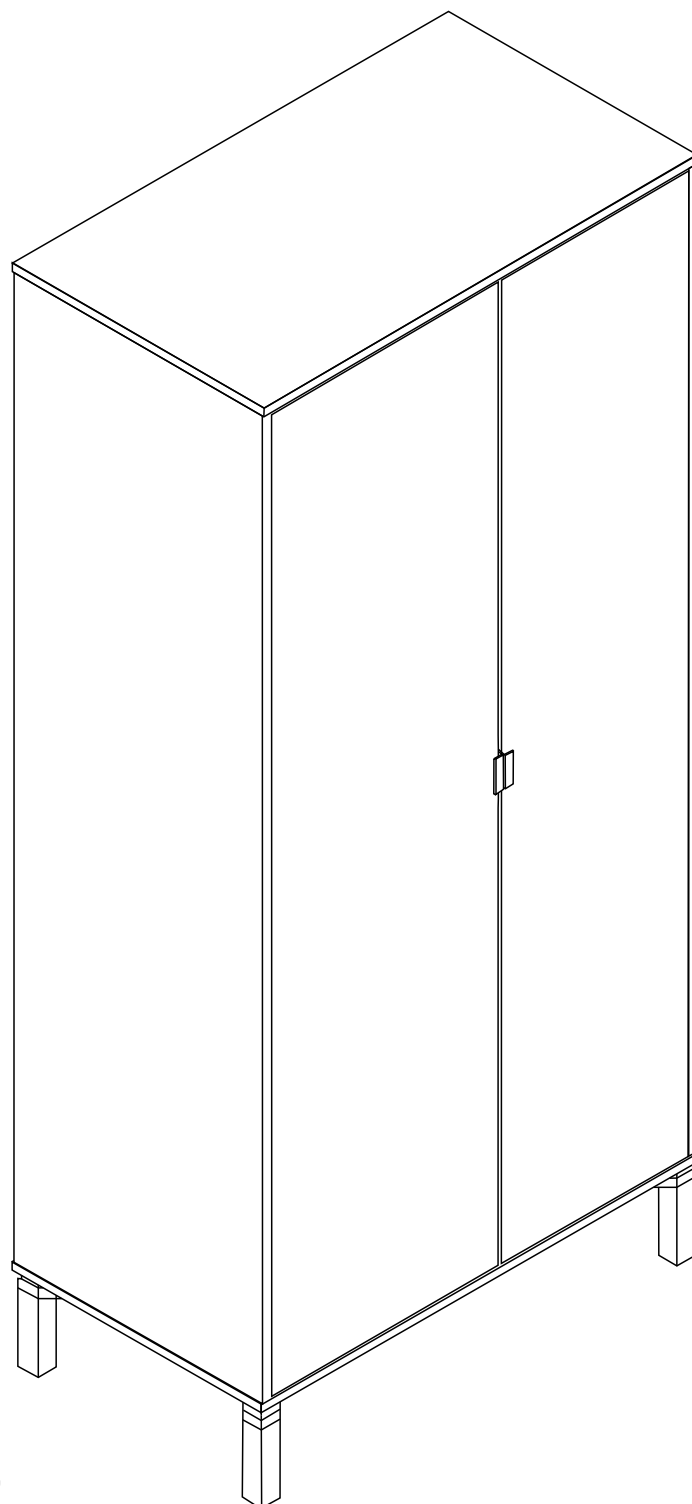

falkk



- **Antes de iniciar a montagem, verifique se você recebeu todos os componentes e peças do produto.**
- Before starting assembly, make sure you have received all the components and parts for the product.
- Antes de comenzar el montaje, asegúrese de haber recibido todos los componentes y piezas del producto.

- **Para montagem, sugerimos contratação de um profissional.**
- For assembly, we suggest hiring a professional.
- Para el montaje, sugerimos contratar a un profesional.

INSTRUÇÕES DE MONTAGEM ASSEMBLY INSTRUCTIONS INSTRUCCIONES DE MONTAJE



Pessoas necessárias.
Necessary people.
Gente necesaria.



Grau de dificuldade - alto.
Difficult level - high.
Nível de dificultad - alto.



Evitar batidas e objetos cortantes.
Avoid bumps and sharp objects.
Evitar golpes y objetos afilados.



Pano levemente umedecido com água, seguido de pano seco.
Cloth slightly dampened with water, followed by a dry cloth.
Paño ligeramente humedecido con agua, seguido de un paño seco.

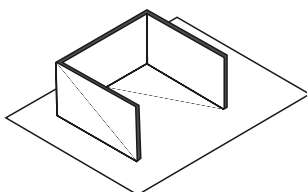

Deve-se fazer a montagem do módulo em cima de uma superfície macia. **Dica:** Usar a caixa.
The module must be mounted on a soft surface.
Tip: Use the box.
El módulo debe montarse sobre una superficie blanda. **Consejo:** Usa la caja.



Não utilizar químicos ou abrasivos na limpeza.
Do not use chemicals or abrasives for cleaning.
No utilice productos químicos o abrasivos

Ferramentas Necessárias required tools / herramientas requeridas (não fornecidas / not provided / no provisto)



Fita métrica
Measuring tape
Cinta métrica



Chave Philips
Philips Screwdriver
Destornillador Philips



Chave Philips Pequena
Philips Screwdriver Small
Destornillador Philips Pequeño



Martelo
Hammer
Martillo



Furadeira
Power Drill
Taladro



ø 6mm e 8mm
ø 6mm and 8mm
ø 6mm y 8mm

Componentes do Módulo

Module Components

Componentes del Módulo



A - Cavilha 8x30 (26x)
 A - Peg 8x30 (26x)
 A - Espiga 8x30 (26x)

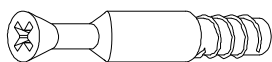

B - Minifix (10x)
 B - Minifix (10x)
 B - Minifix (10x)

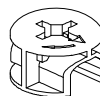

C - Tambor (14x)
 C - Drum (14x)
 C - Tambor (14x)

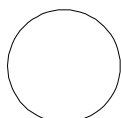

D - Tapa Furo Adesivo (14x)
 D - Self Adhesive Cap Cover (14x)
 D - Tapa Aguejo Autoadhesivos (14x)



F14 - Parafuso da dobradiça Ø4x16 (36x)
 F14 - hinge screw Ø4x16 (36x)
 F14 - Tornillo de bisagra Ø4x16 (36x)

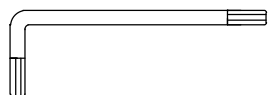

R1 - Chave Allen (1x)
 R1 - Key Allen (1x)
 R1 - Llave Allen (1x)

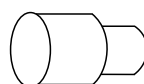

L1 - Suporte para prateleira (16x)
 L1 - Shelf support (16x)
 L1 - Soporte de estantería (16x)



F9 - Parafuso Euro Ø5x35 (18x)
 F9 - Screw Euro Ø5x35 (18x)
 F9 - Tornillo Euro Ø5x35 (18x)

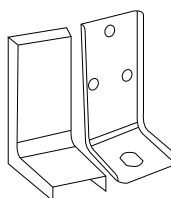

Parafuso 4x16 (3x)
 Parafuso 6x60 (1x)
 Bucha 8mm (1x)
 Suporte parede (1x)
 Capa suporte (1x)

H1 - Kit suporte com capa para estante (1x)
 H1 - Support kit with shelf cover (1x)
 H1 - Kit de soporte con cubierta de estante (1x)

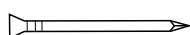

E - Prego 10x10 (57x)
 E - Nail 10x10 (57x)
 E - Clavo 10x10 (57x)

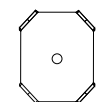

V - Fixador para costa (13x)

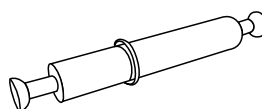

X - Pino Duplo Metal (2x)
 X - Double metal pin (2x)
 X - Pasador metálico doble (2x)

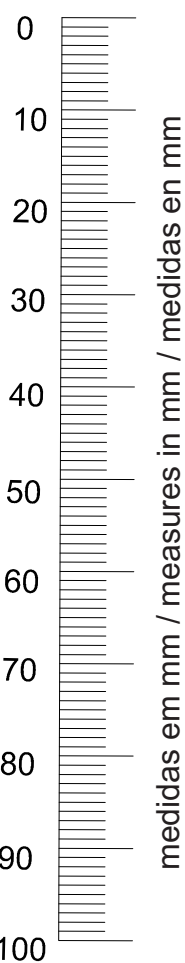

medidas em mm / measures in mm / medidas en mm

Componentes do Módulo

Module Components

Componentes del Módulo

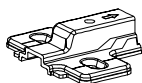

J2 - Calço de dobradiça (8x)
 J2 - Hinge shim (8x)
 J2 - Cuña de bisagra (8x)

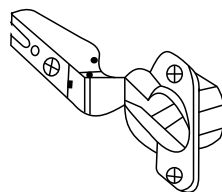

K1 - Dobradiça (8x)
 K1 - Hinge (8x)
 K1 - Bisagra (8x)

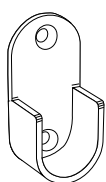

AB - Suporte para cabideiro (2x)
 AB - Clothes rack support (2x)
 AB - Soporte para perchero (2x)

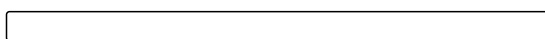

AB - Cabideiro (1x)
 AB - Coat rack (1x)
 AB - Perchero (1x)

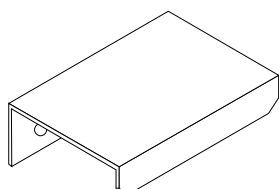

S - Puxador (2x)
 S - Bar Pull (2x)
 S - Tirador (2x)



F11 - Parafuso Euro Ø6x10 (4x)
 F11 - Screw Euro Ø6x10 (4x)
 F11 - Tornillo Euro Ø6x10 (4x)



AA - Batente de silicone (2x)
 AA - Silicone stopper (2x)
 AA - Tapón de silicona (2x)

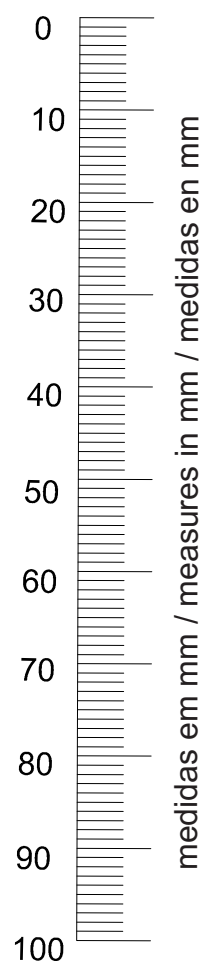

Partes do módulo

Module Parts

Partes del módulo

- 1** Base Superior (1x)
Top Base (1x) / Base Superior (1x)
- 2** Base Inferior (1x)
Botton Base (1x) / Base Inferior (1x)
- 3** Lateral Direita (1x)
Right Side (1x) / Lado Derecho (1x)
- 4** Lateral Esquerda (1x)
Left Side (1x) / Lado Izquierdo (1x)
- 37** Costa Maior (1x)
Mayor Coast (1x) / Costa Major (1x)
- 5** Costa Menor (1x)
Minor Coast (1x) / Costa Menor (1x)
- 9** Divisória (1x)
Partition (1x) / División (1x)
- 16** Prateleira Fixa Maior (1x)
Largest fixed Shelf (1x) / Estante fija Major (1x)
- 15** Prateleira Fixa Menor (1x)
Smaller fixed Shelf (1x) / Estante fija Menor (1x)
- 39** Prateleira Móvel Direita (3x)
Right mobile Shelf (3x) / Estante móvil derecho (3x)
- 38** Prateleira Móvel Esquerda (1x)
Left mobile Shelf (1x) / Estante móvil izquierdo (1x)
- 12** Porta Esquerda (1x)
Left Door (1x) / Puerta Izquierda (1x)
- 11** Porta Direita (1x)
Right Door (1x) / Puerta Derecha (1x)
- 100** Pés (4x)
Foot (4x) / Pies (4x)

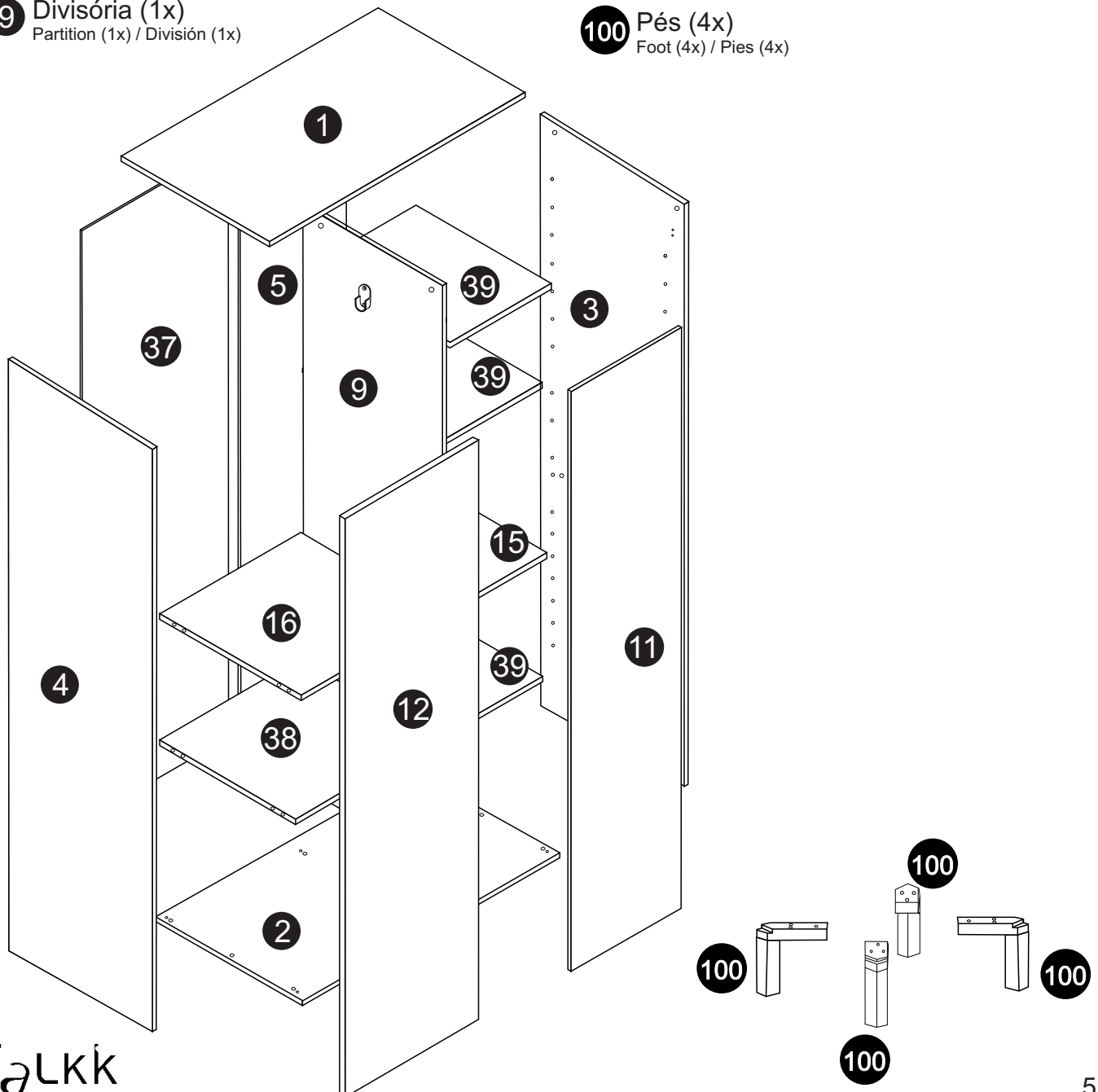

Pré montagem do módulo



Module pre-assembly

Premontaje del módulo

01

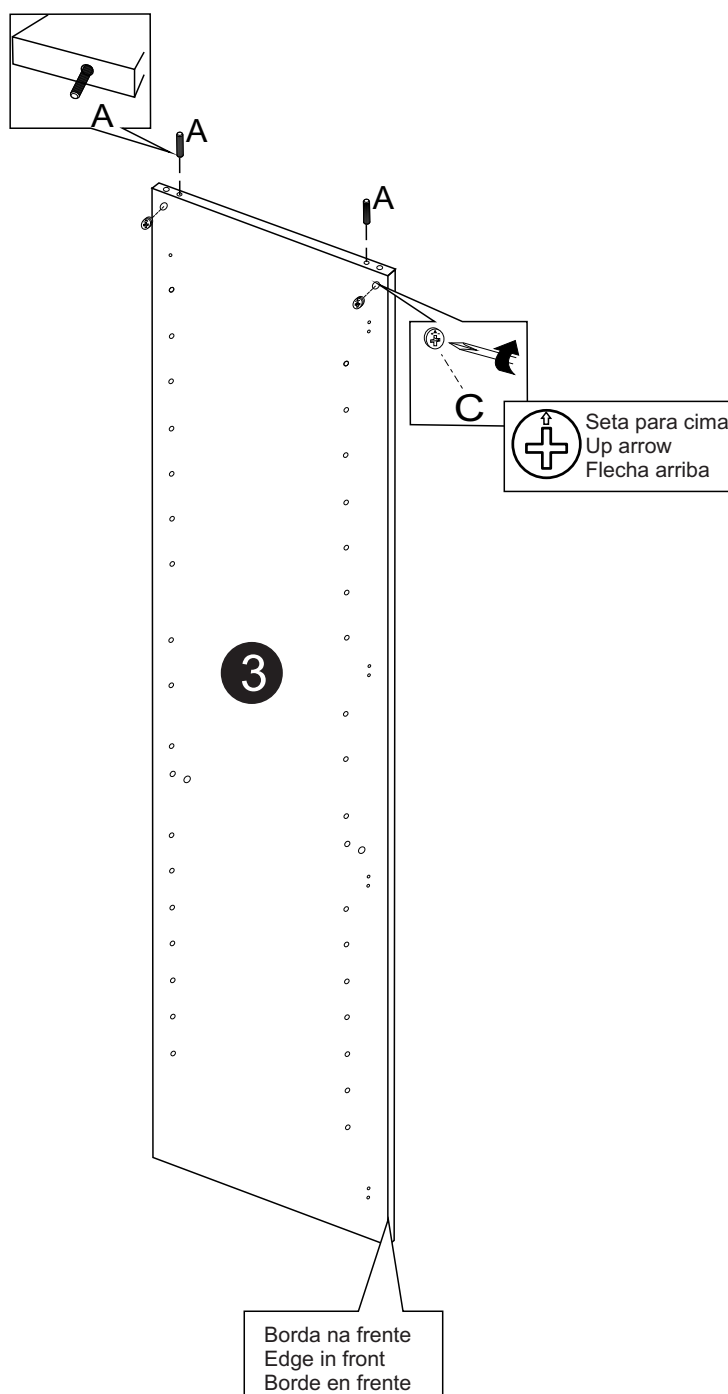
Lateral Direita
Right Side
Lado Derecha





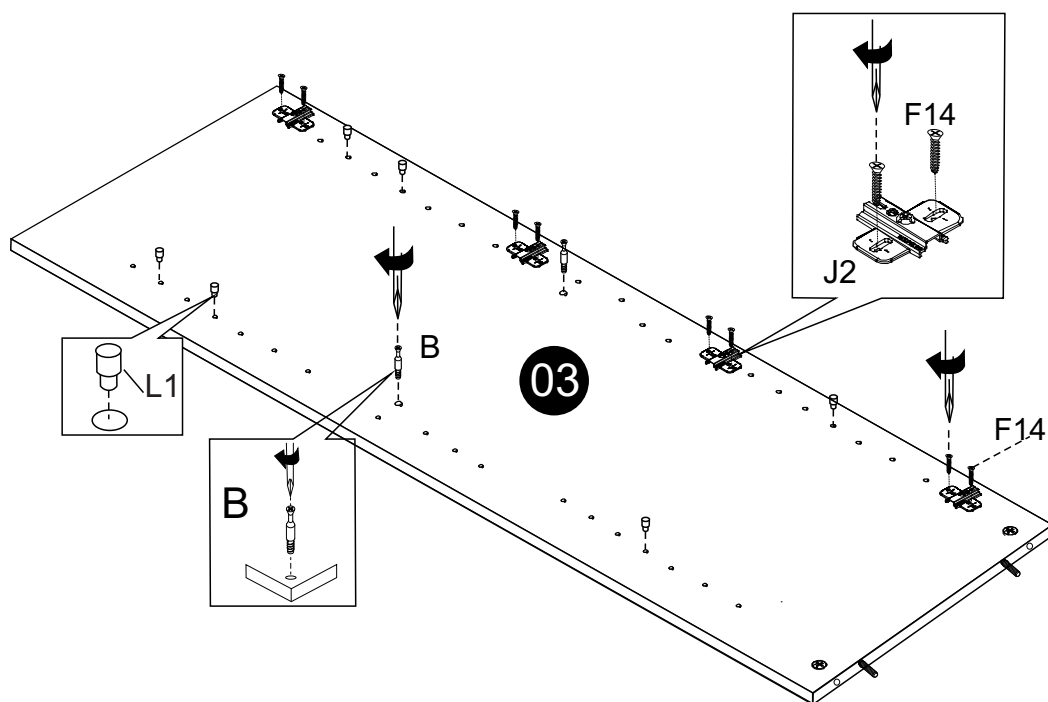

A		2 PCS
C		2 PCS

12

Lateral Direita
Right Side
Lado Derecho



L1		6 PCS
B		2 PCS
J2		4 PCS
F14		8 PCS

02

Divisória
Partition
División

Visualização dos 02 lados
Viewing from 02 sides
Viendo desde 02 lados

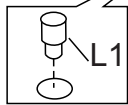
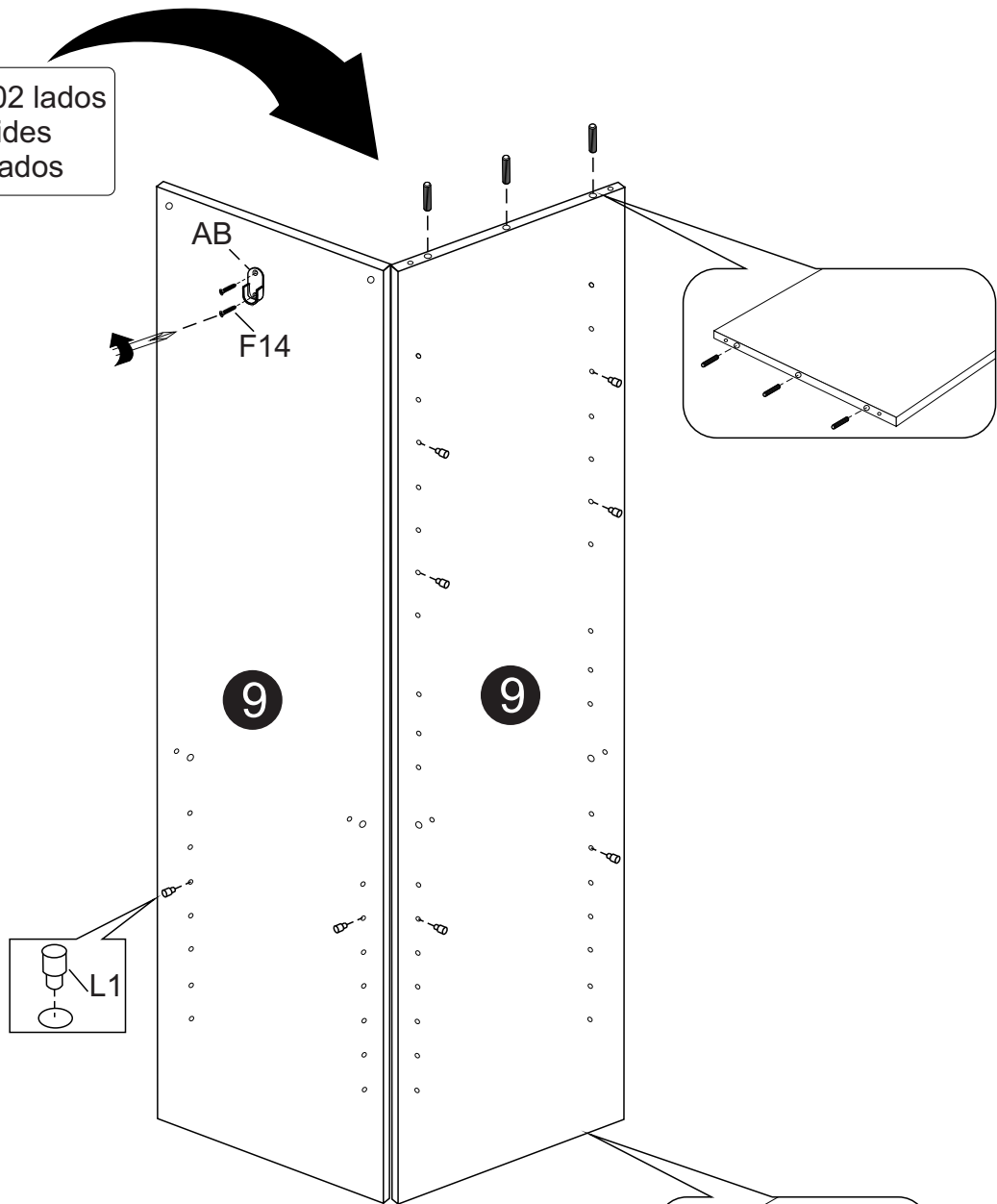

Furação embaixo da
divisória
Drilling under the divider
Furación debajo del divisor

F14		2 PCS
L1		8 PCS
A		6 PCS

03

Lateral Esquerda
Left Side
Lado Izquierdo

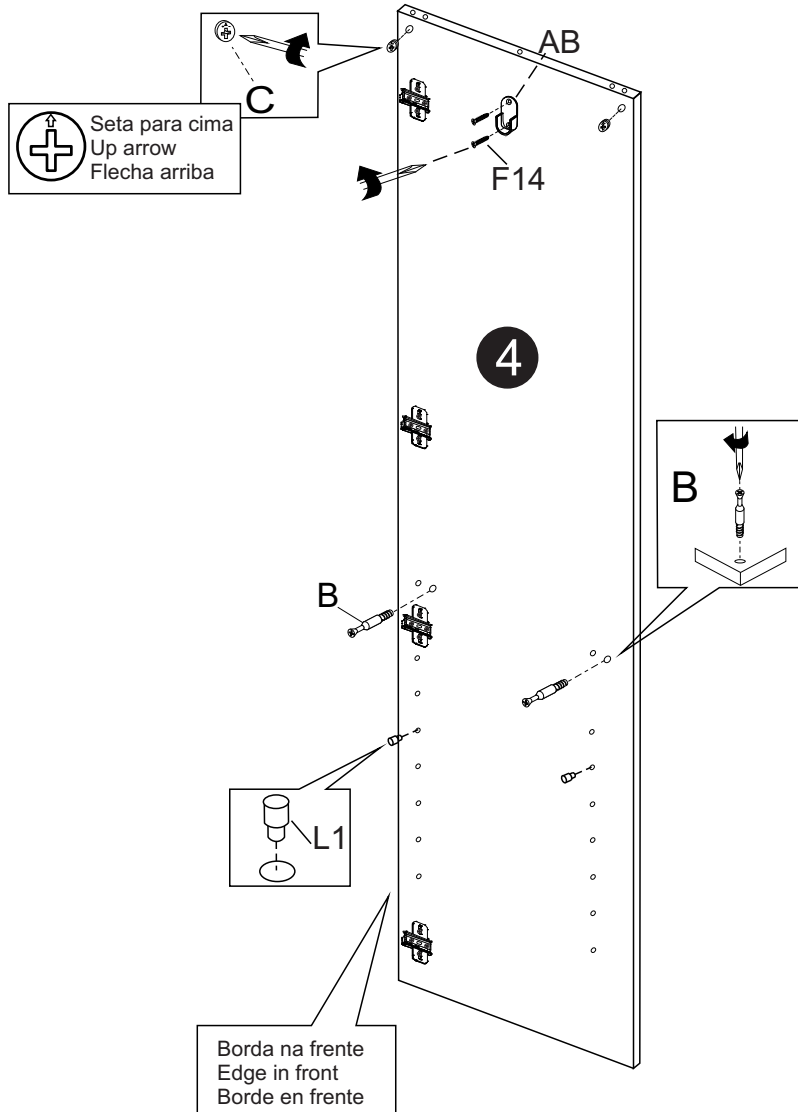

04

Base Inferior - Conferencia do desenho parte externa
Botton Base - External design conference
Base Inferior - Conferencia de dibujo exterior

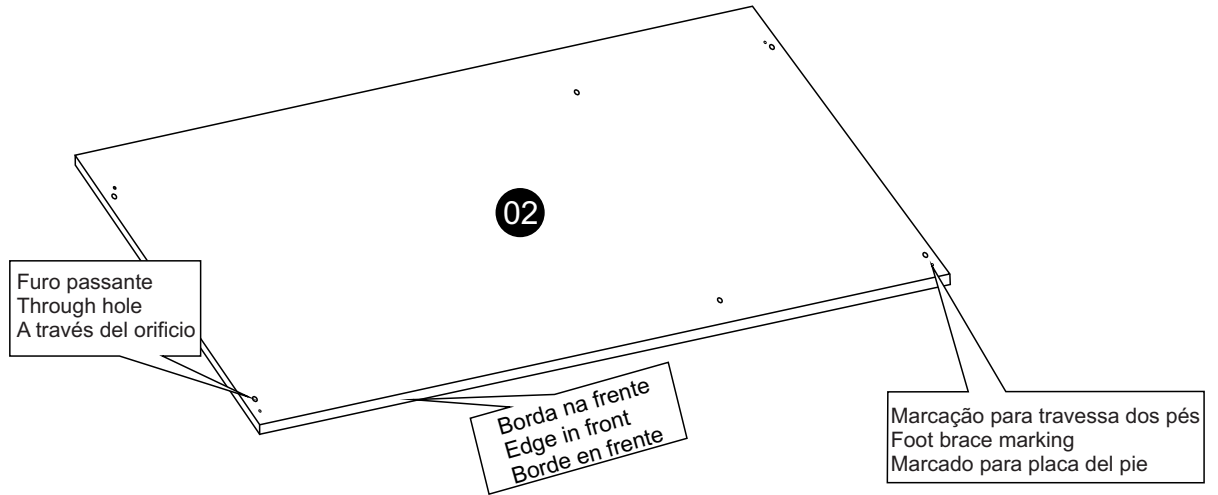

05

Base Inferior - Conferencia do desenho parte interna
Botton Base - Internal design conference
Base Inferior - Conferencia de dibujo interior

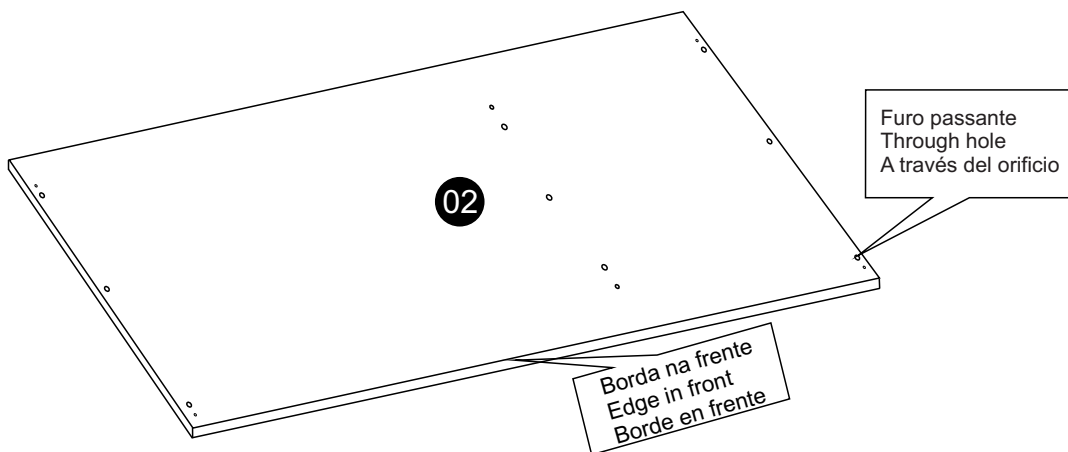

06

Base Superior - Conferencia do desenho parte interna
Top Base - Internal design conference
Base Superior - Conferencia de dibujo interno

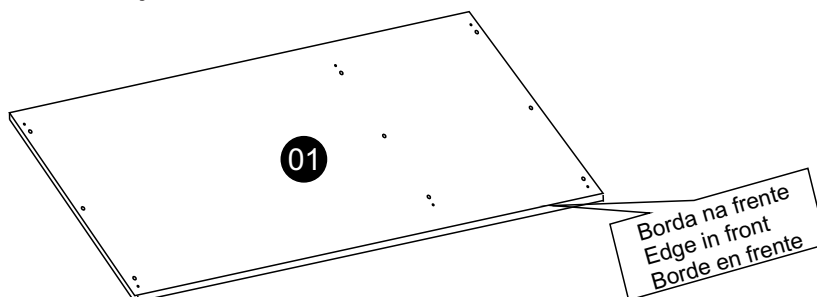

07

Costa Maior
Coast Mayor
Costa Major

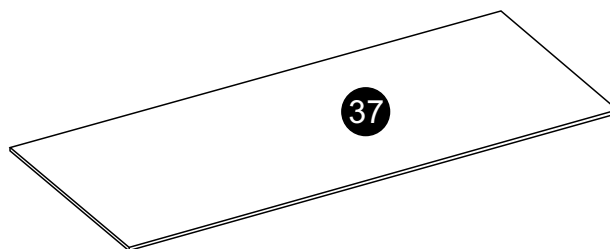

08

Costa Menor
Coast Minor
Costa Menor

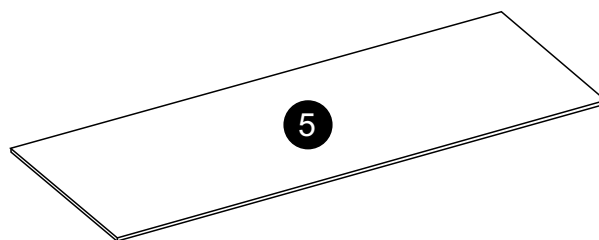

09

Prateleira Fixa Menor - Conferencia do desenho
Smaller Fixed Shelf - Design conference
Estante Fija Menor - Conferencia de dibujo

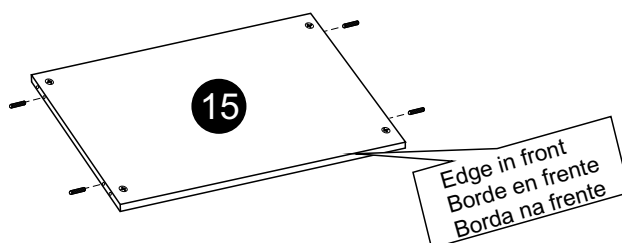

10

Prateleira Fixa Maior - Conferencia do desenho
Larger Fixed Shelf - Design conference
Estante Fija Major - Conferencia de dibujo

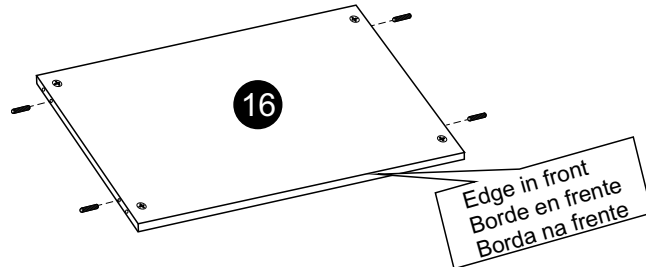

A  04 PCS

11

Prateleira Móvel Direita - Conferencia de desenho
Right Mobile Shelf - Design conference
Estante Móvil Derecho - Conferencia de dibujo

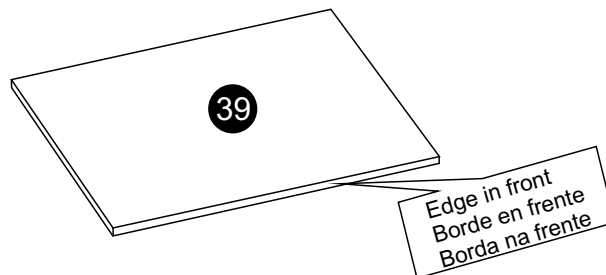

12

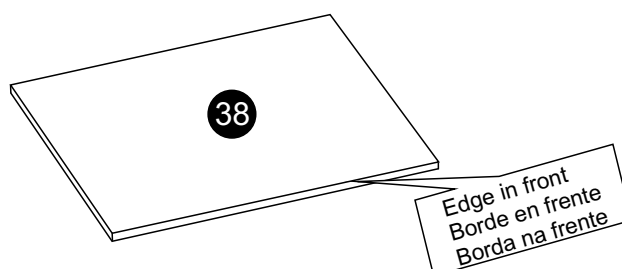

Prateleira Móvel Esquerda - Conferencia de desenho
Left Mobile Shelf - Design conference
Estante Móvil Izquierda - Conferencia de dibujo

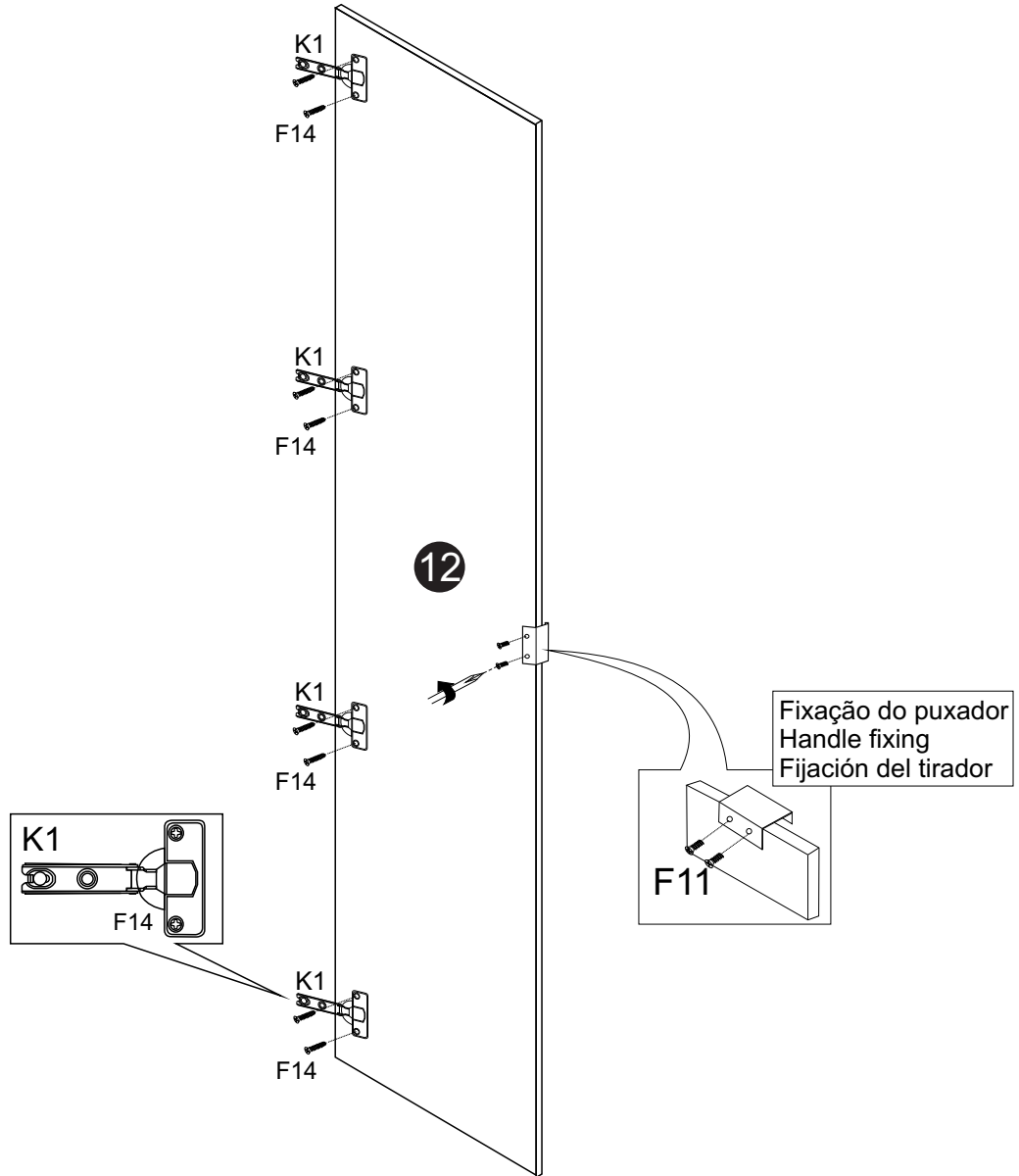

12

Porta Esquerda + Puxador
 Left Door + Bar Pull
 Puerta Izquierda + Tirador





F11		2 PCS
K1		4 PCS
F14		8 PCS

12

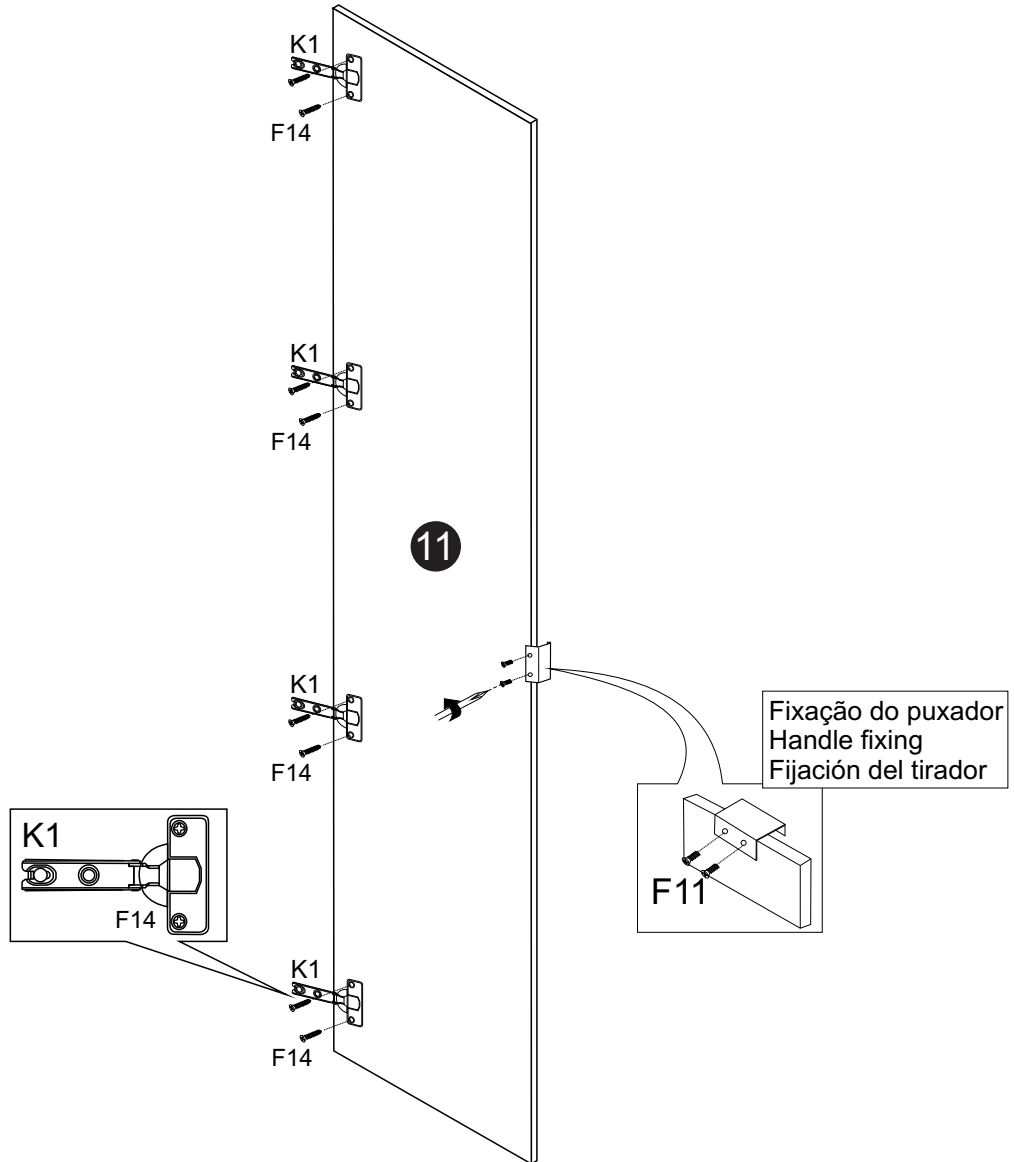
Porta Direita + Puxador
Right Door + Bar Pull
Puerta Derecha + Tirador



F11		2 PCS
K1		4 PCS
F14		8 PCS

Montagem do módulo

Module assembly

Montaje del módulo

01

Lateral Esquerda + Prateleira Fixa

Left Side + Fixed Shelf

Lado Izquierdo + Estante Fijo

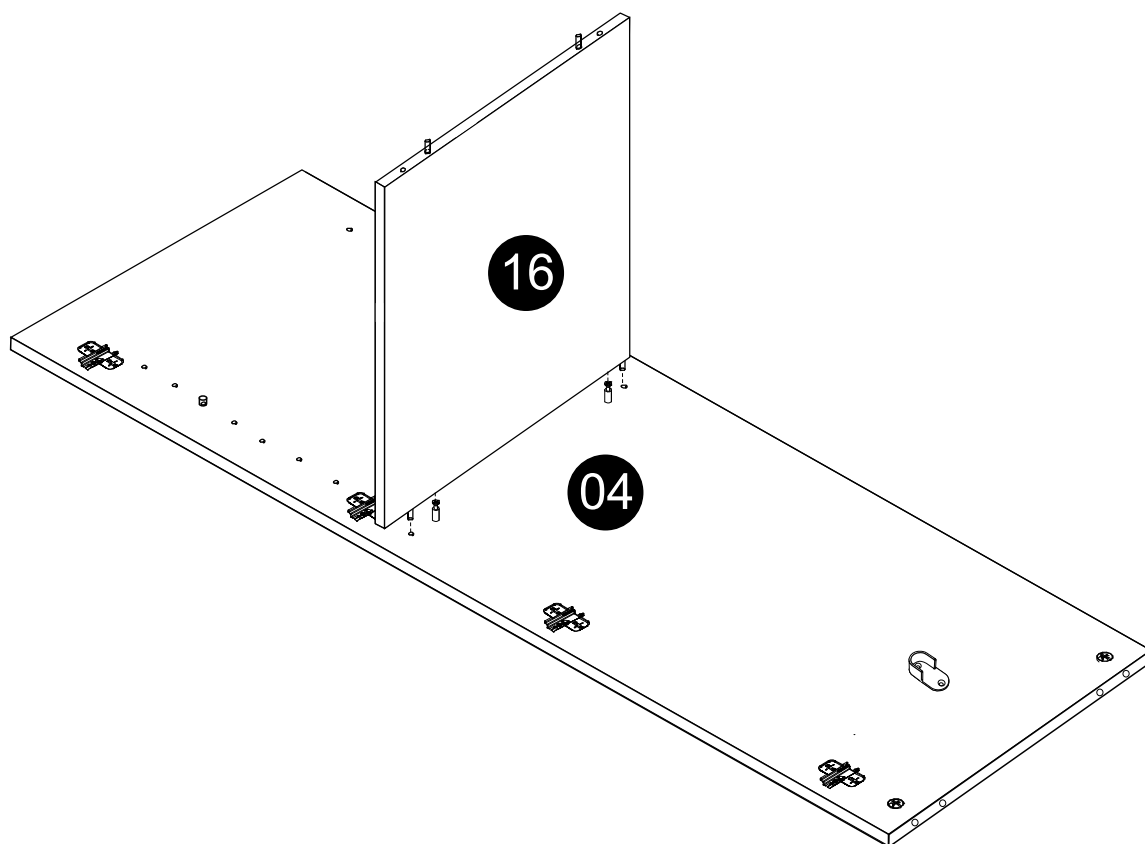

02

Divisória
Partition
División

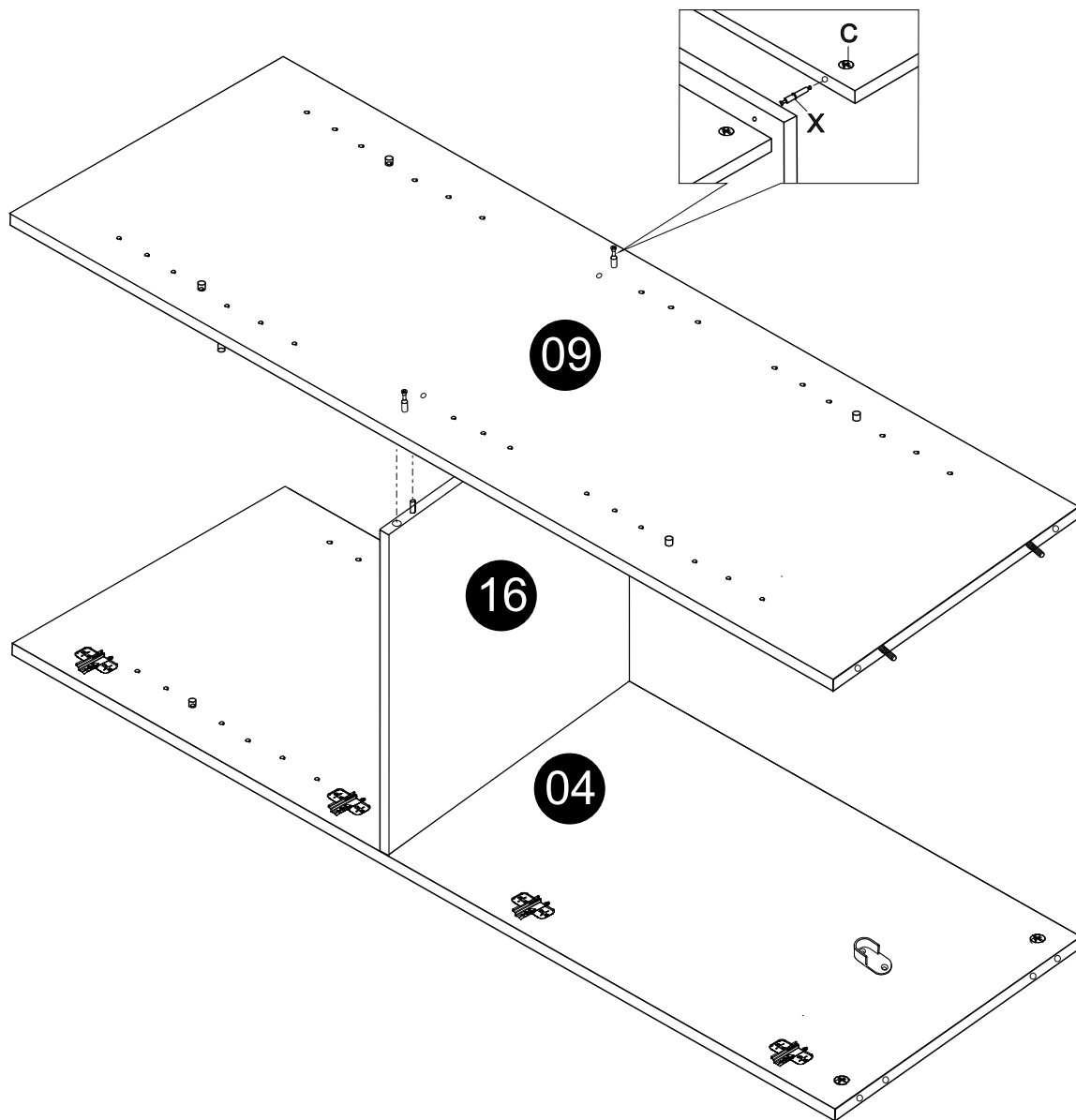

X  2 PCS

03

Divisória + Prateleiras
Divider + Shelves
Divisor + Estantes

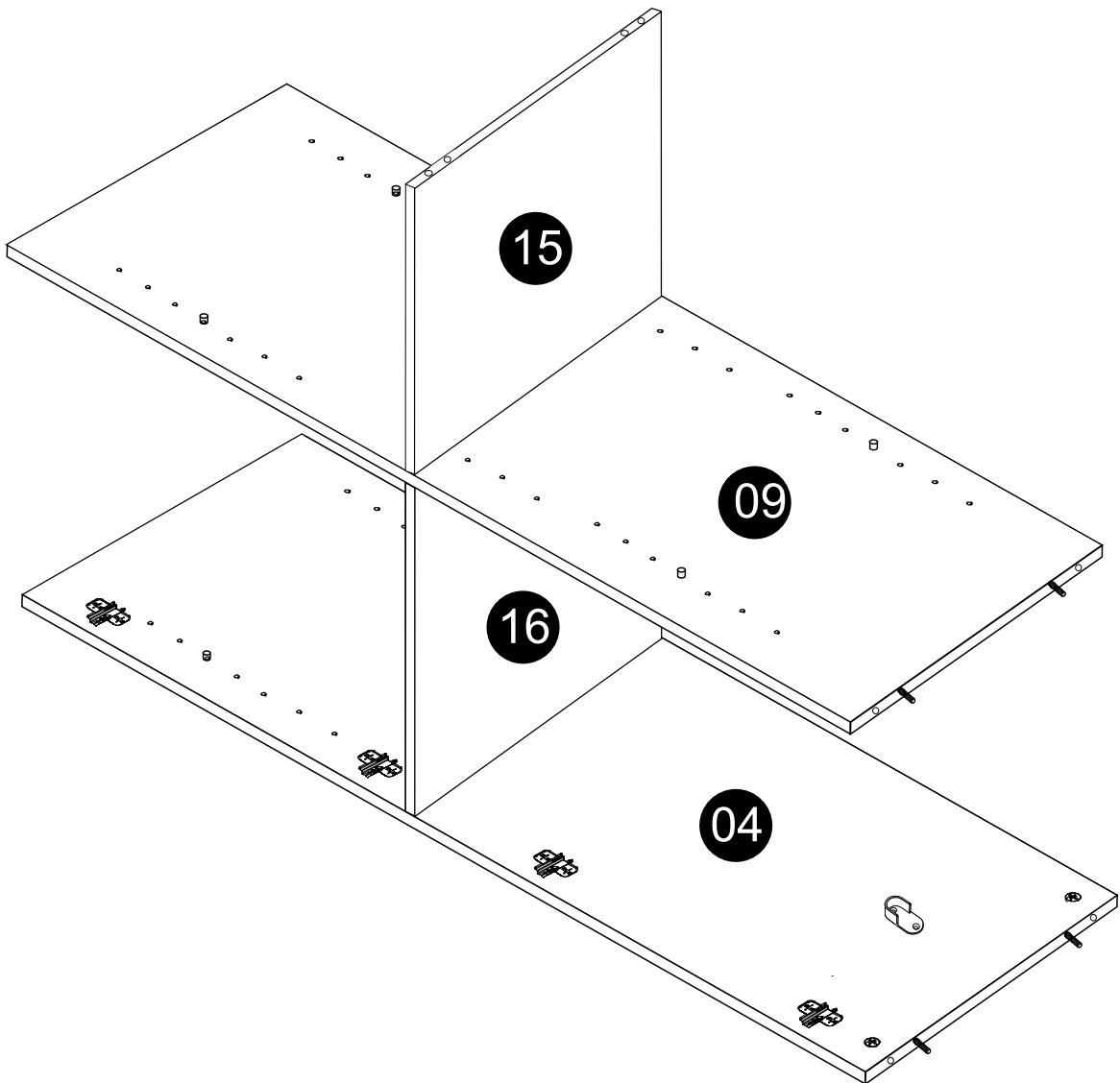

04

Lateral Direita
Right Side
Lado Derecho

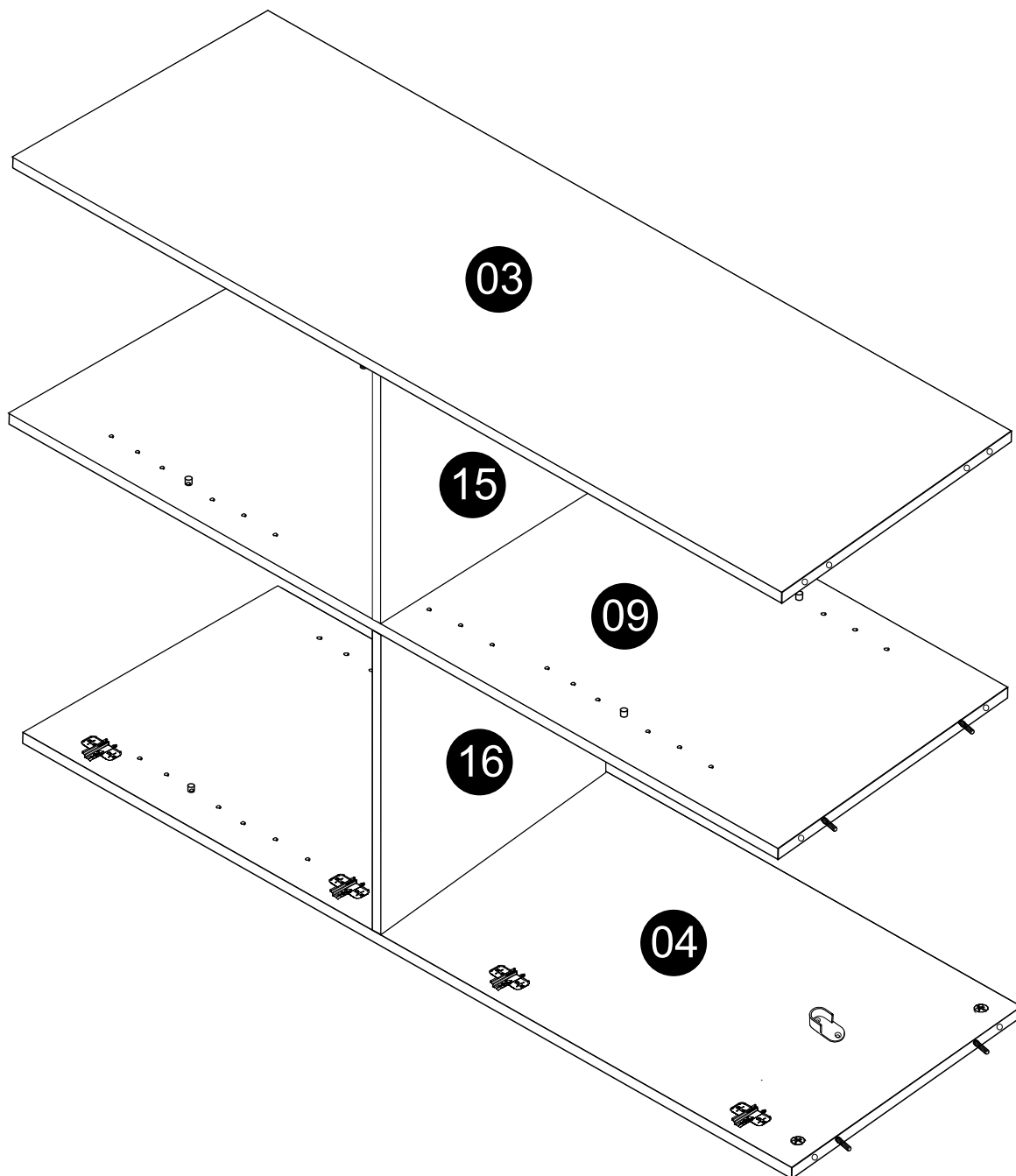

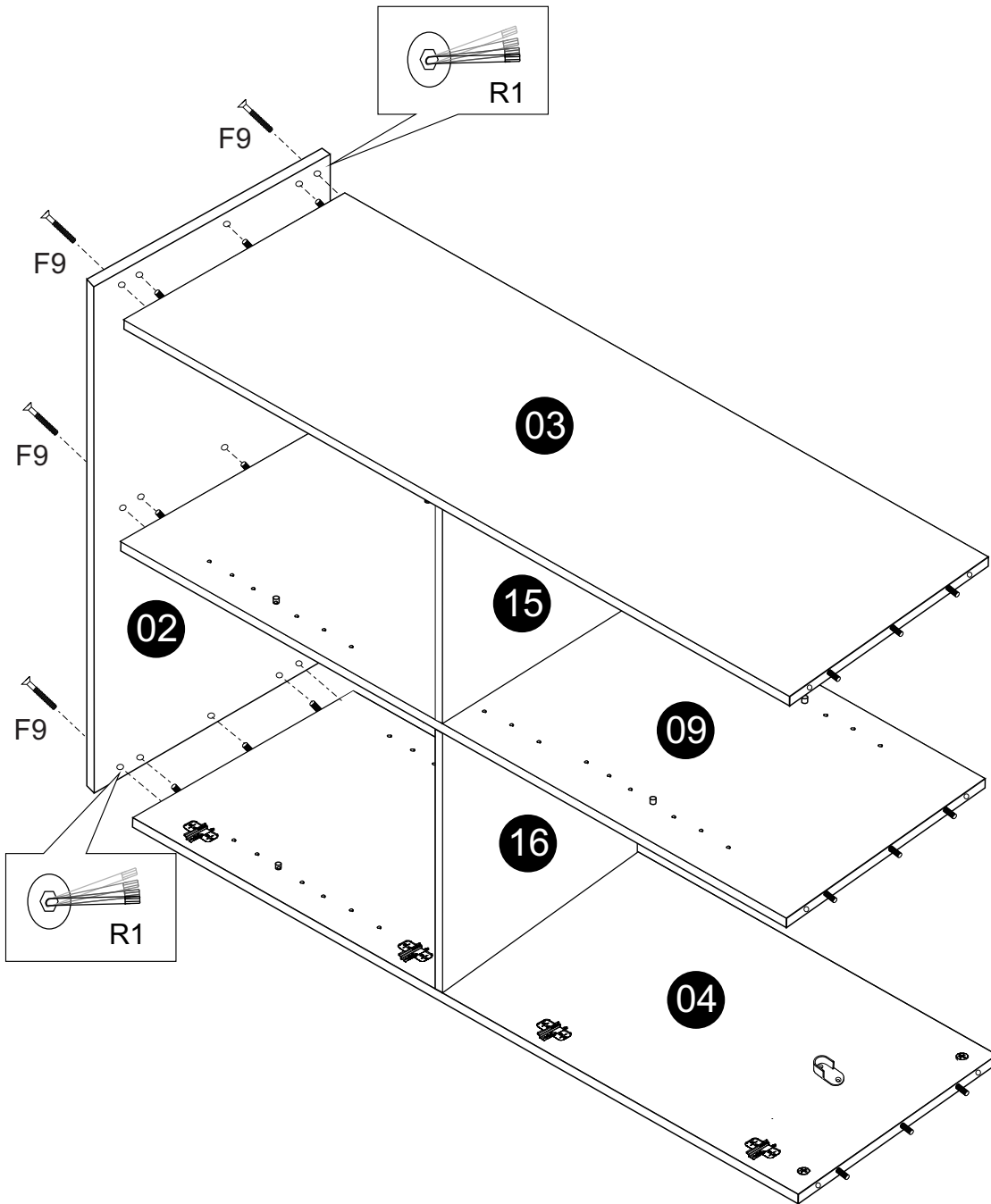

05

Base Inferior
Bottom Base
Base Inferior

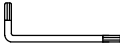

Utilizar a chave Allen para fixar a base inferior nas laterais.
Use the key Allen to fix the lower base on the sides.
Usa la llave Allen para fijar la base inferior a los lados.

R1 

F9		6 PCS
R1		1 PCS

06

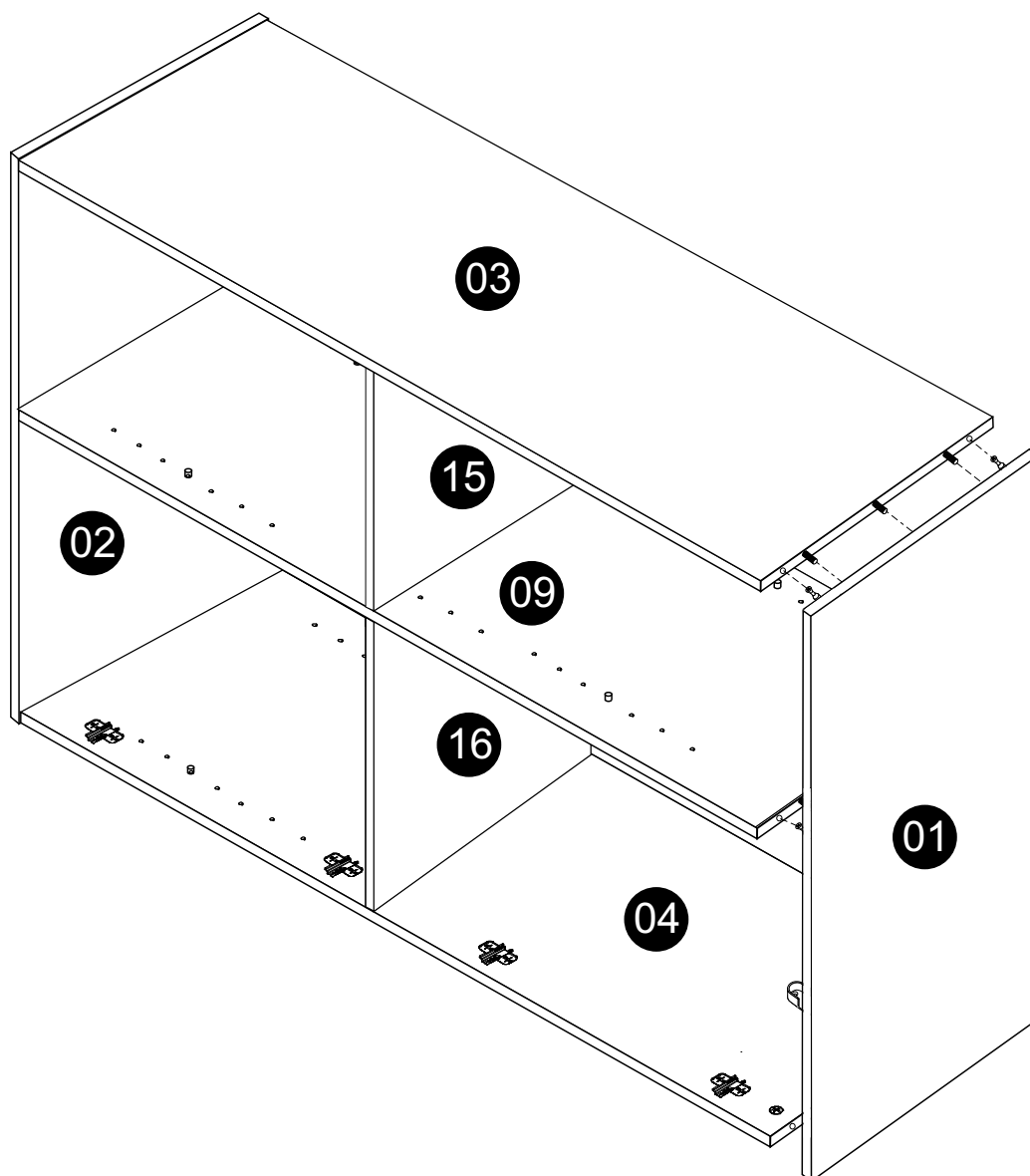

Base Superior
Top Base
Base Superior

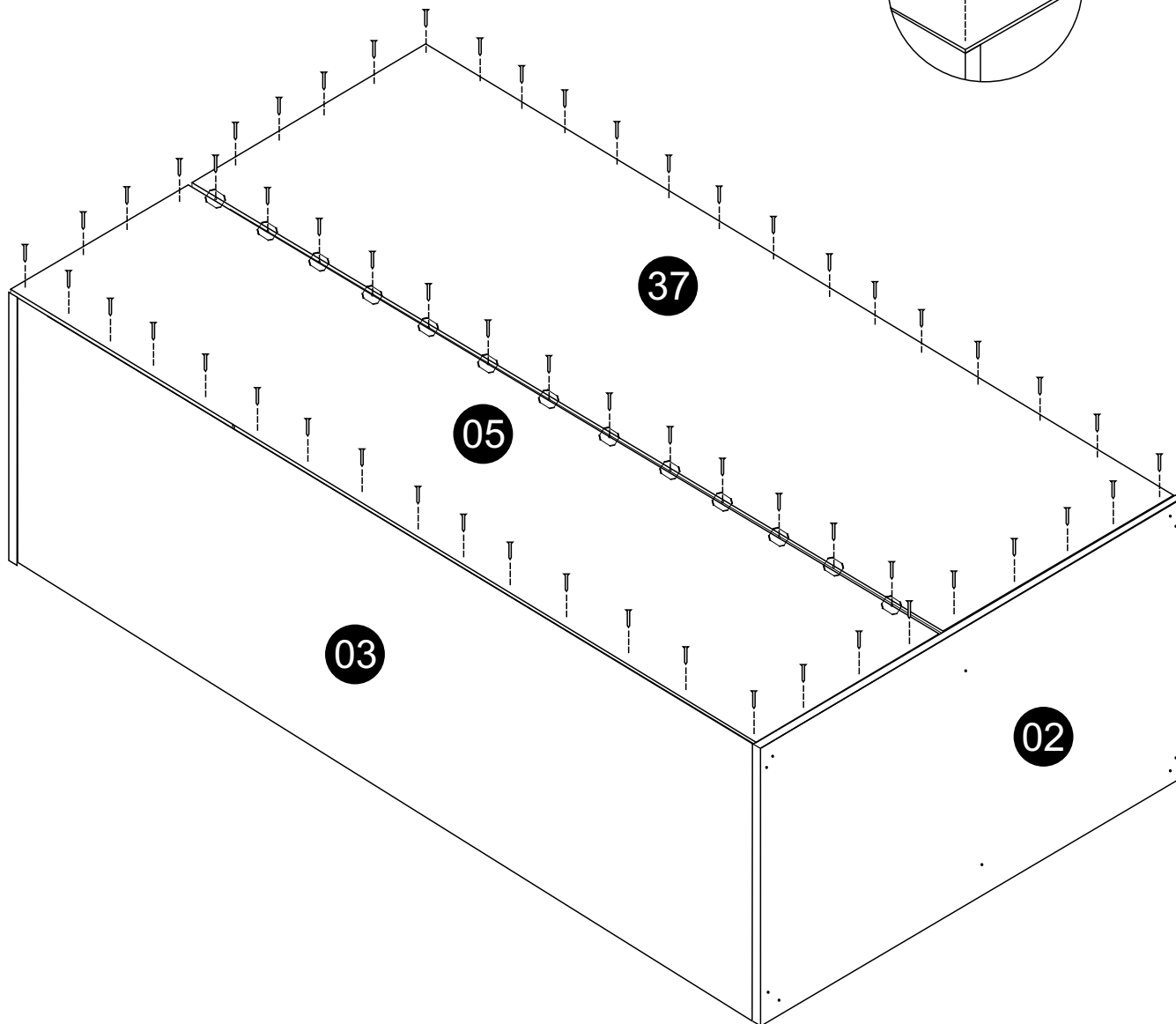
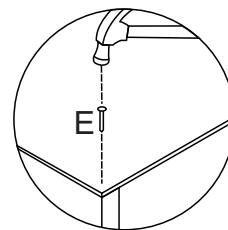

07

Montagem da costa
Mounting of coast
Montaje del costa



E		57 PCS
V		13 PCS

08

Montagem da costa
Mounting of coast
Montaje del costa

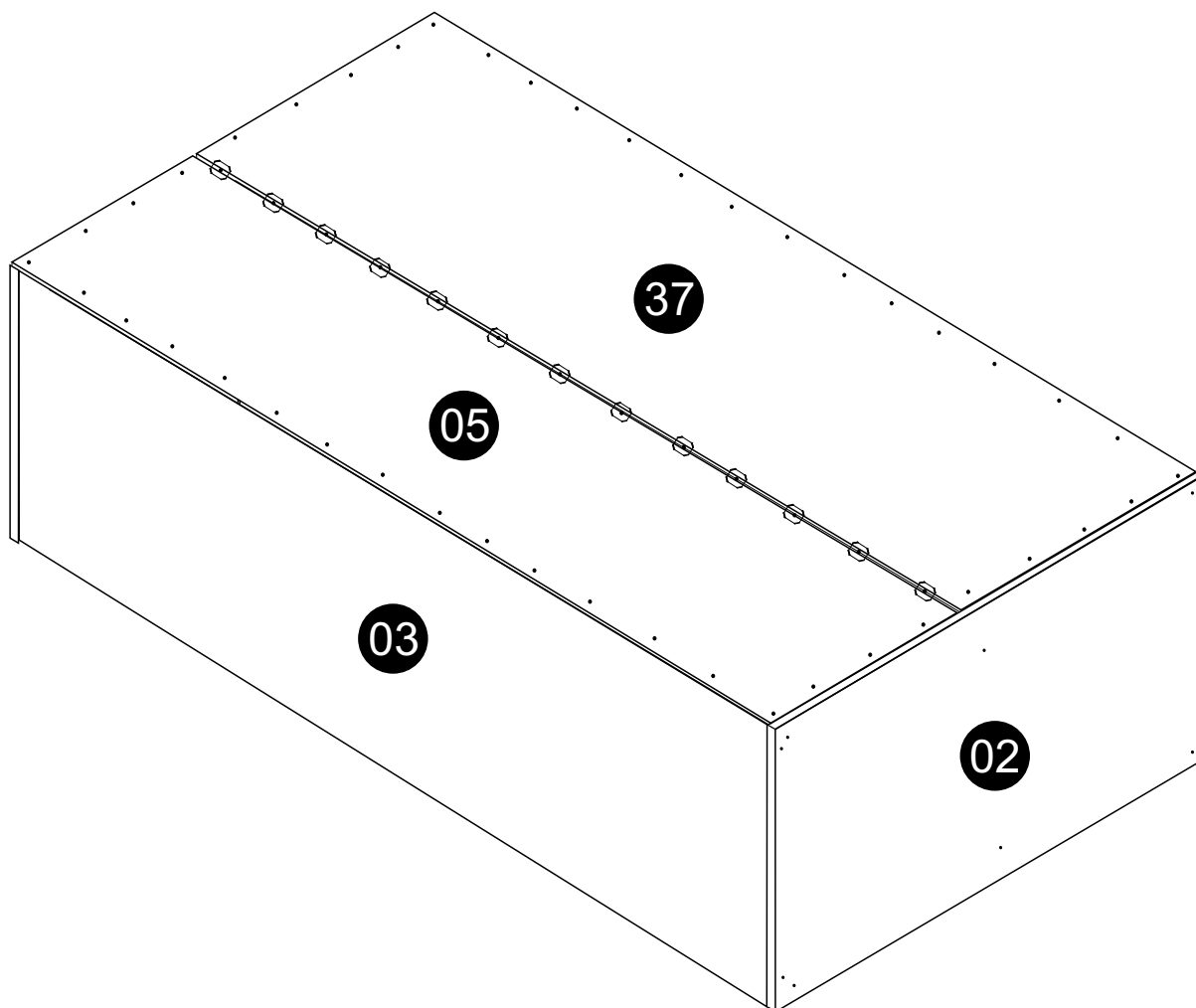

09

Travessas e pés
Board and feet
Tablas y pies



- Alinhar parafusos com furos e utilizar a sua força para parafusar.
- Align screws with holes and use your strength to screw.
- Guía los tornillos con agujeros y usa tu fuerza para atornillar.

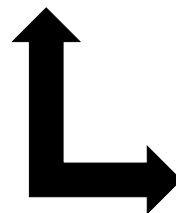
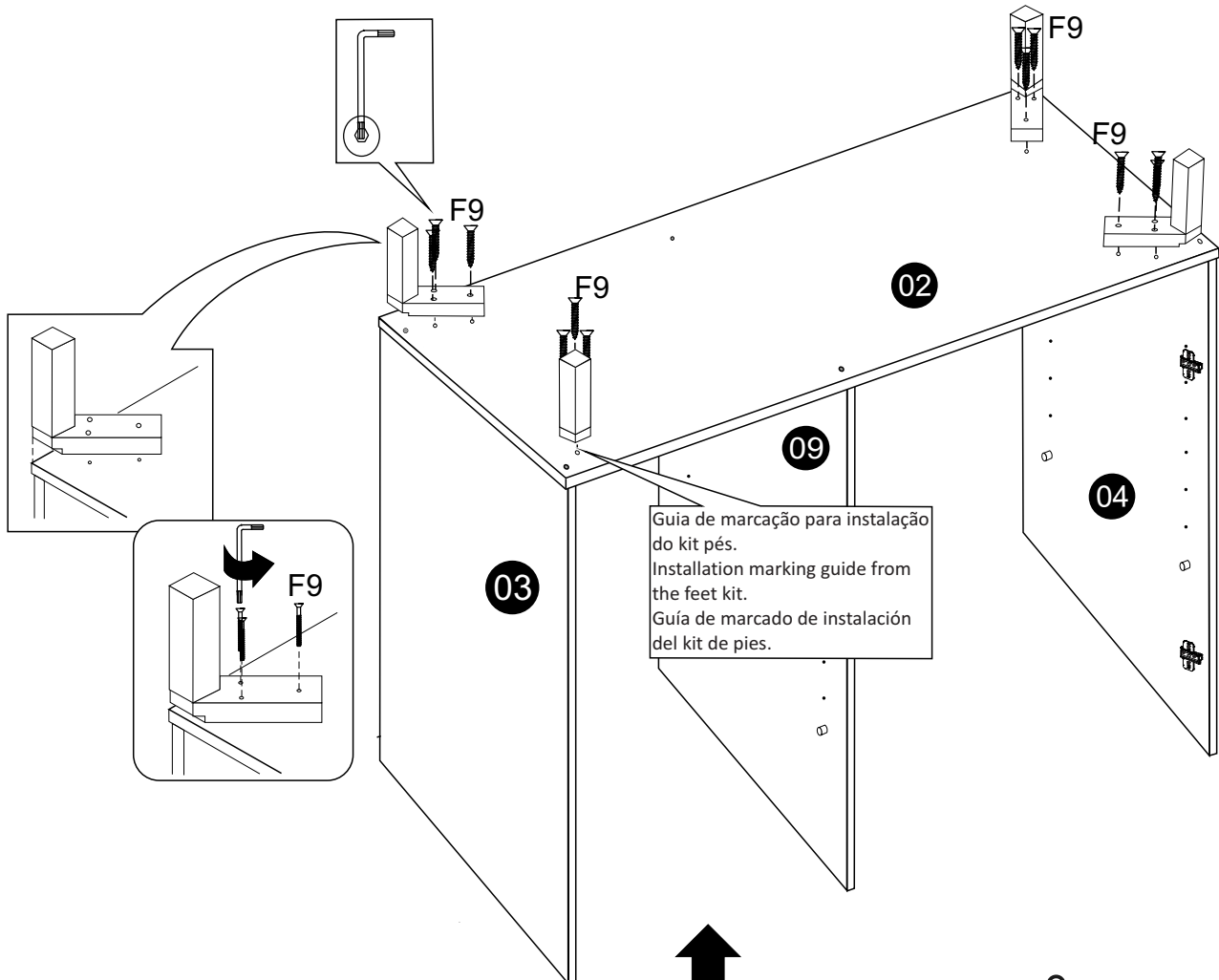

Desenho com laterais e divisória mais baixas
Design with lower sides and divider
Diseño con laterales inferiores y divisor



- No início da instalação dos pés, utilizar a chave R1 na vertical e no final na horizontal.
- At the beginning of the installation of the feet, use the key R1 vertically and at the end horizontally.
- Al inicio de la instalación de los pies, utilice la llave R1 en forma vertical y al final en forma horizontal.

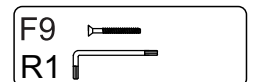

10

Prateleiras
Shelf
Estantes

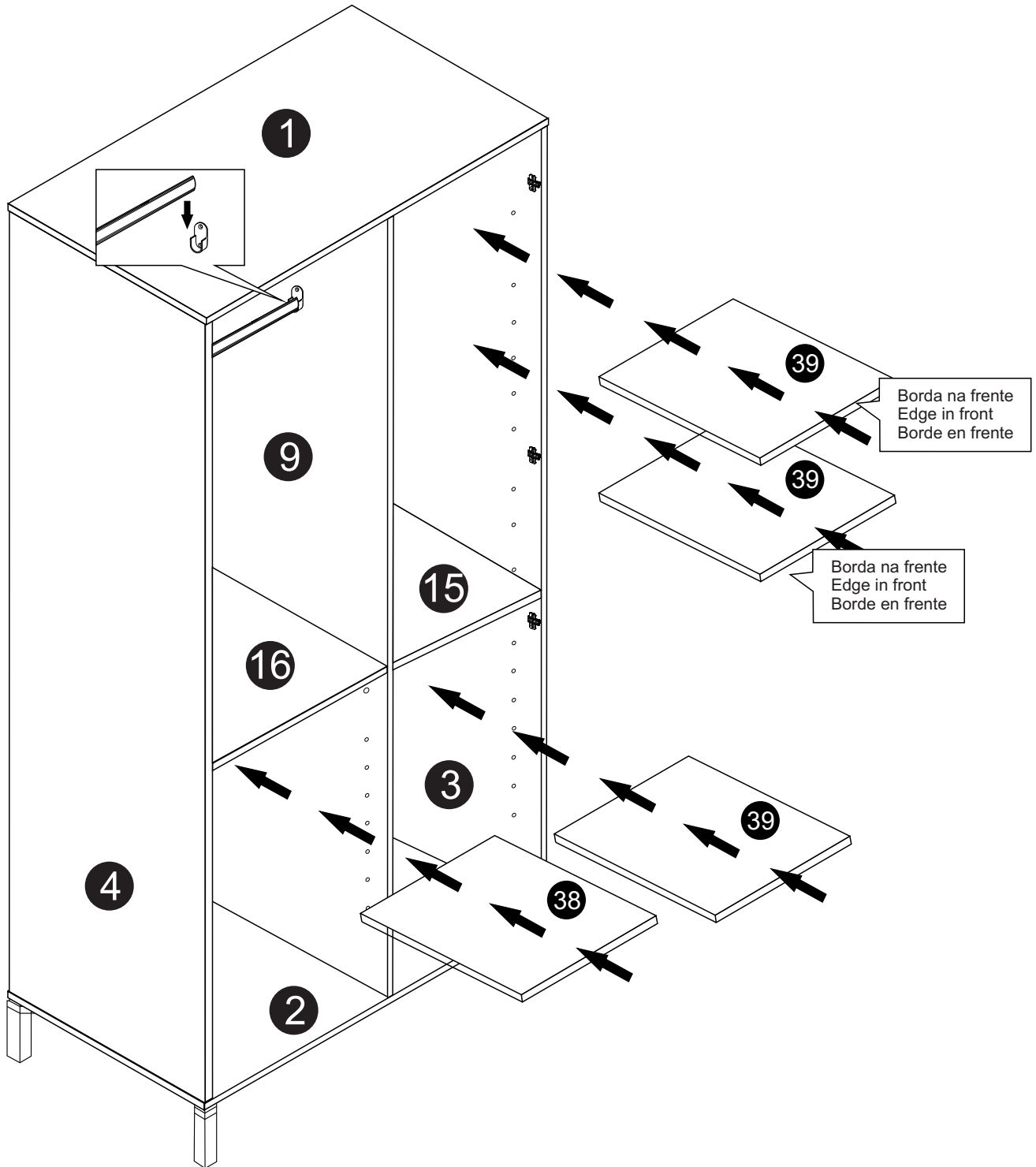

Kit Anti tombamento - Seguir o manual do produto
 Kit Anti tipping - Follow the product manual
 Kit Antivuelco - Siga el manual del producto

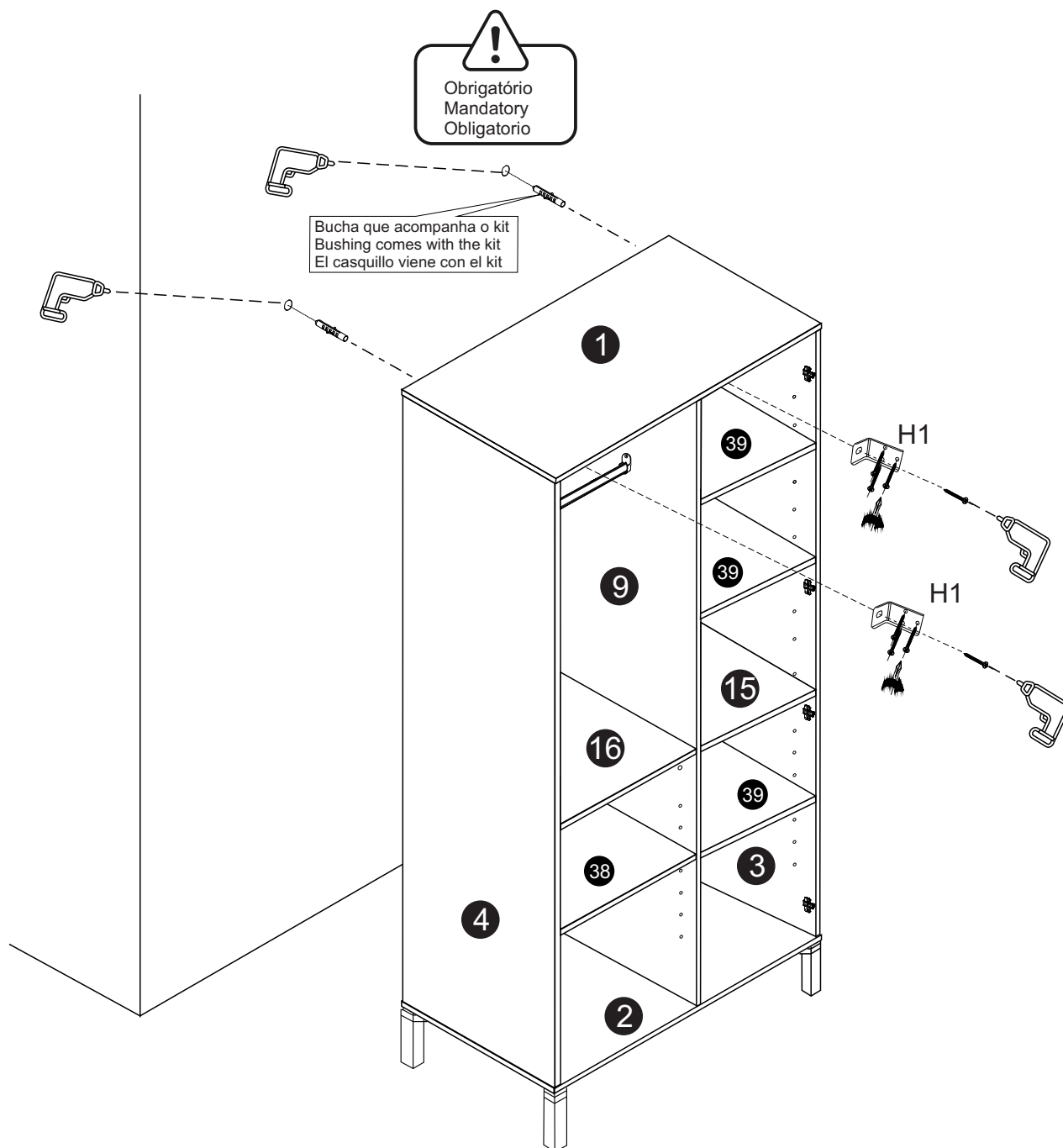

H1  01 Kit

12

Porta
Door
Puerta

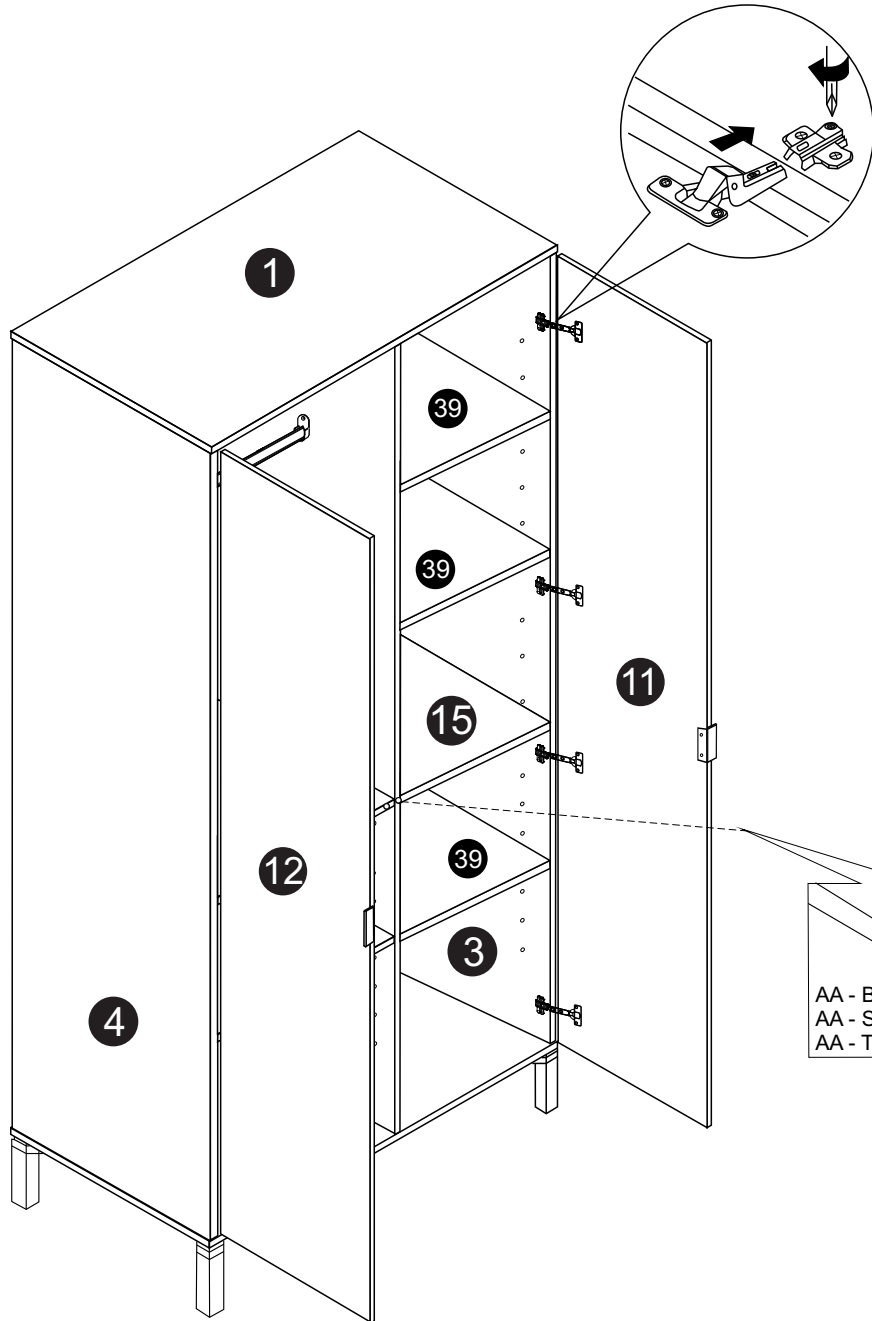

AA - Batente de silicone (2x)
 AA - Silicone stopper (2x)
 AA - Tapón de silicona (2x)

AA ○ 2 PCS

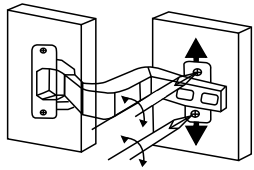
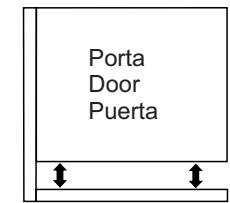

Ajuste de altura
 Height
 adjustment

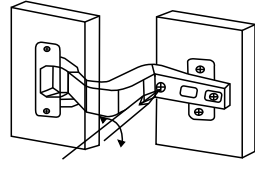
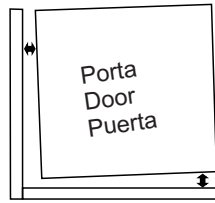

Ajuste interno
 Internal
 adjustment

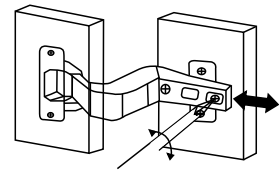
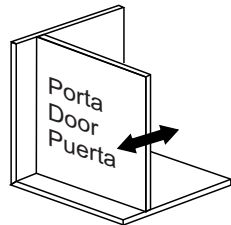

Ajuste de profundidade
 Depth
 adjustment

13

Finalizado
Finished
Acabado

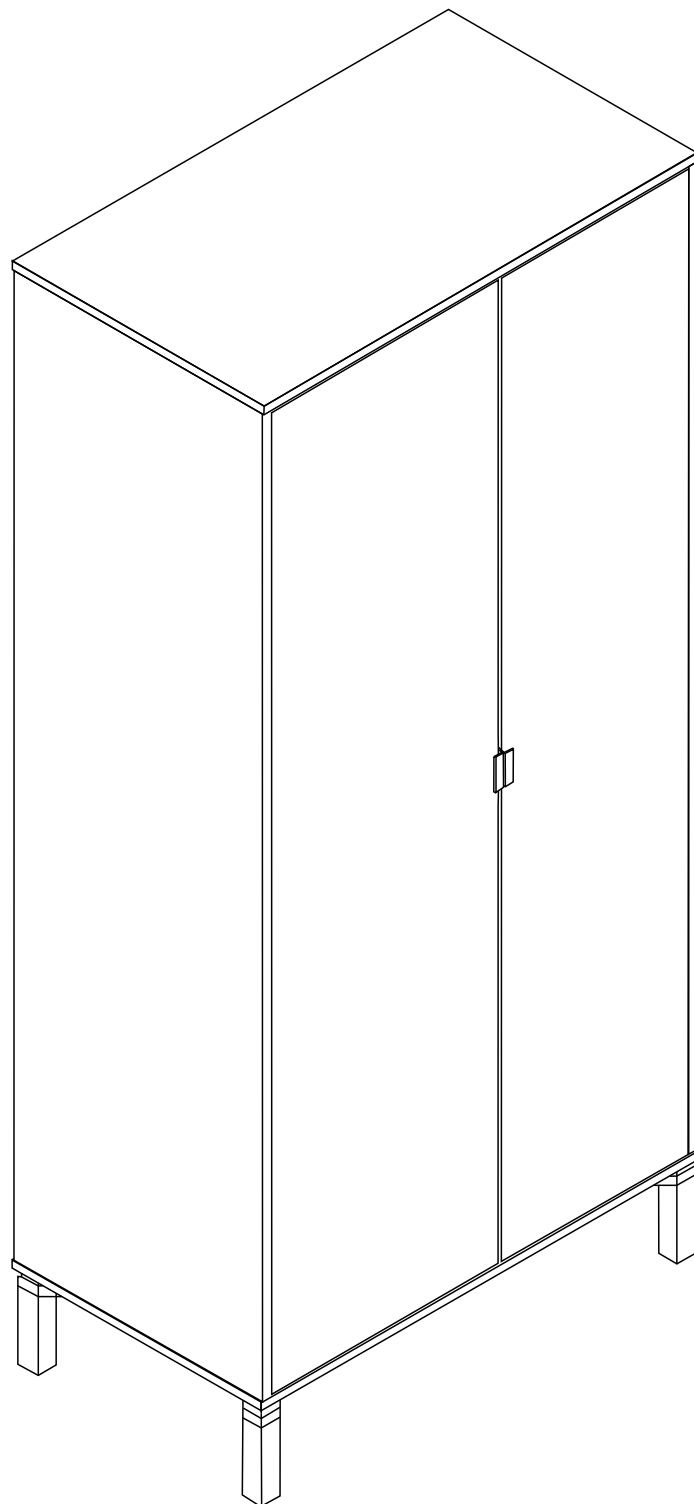



Ferimentos por esmagamentos graves ou fatais podem ocorrer com a queda do móvel.

Para reduzir o risco de tombamento de móveis:

- SEMPRE instale o sistema de antitombamento fornecido.
- NUNCA instale uma TV sobre esse produto.
- NUNCA permita que crianças fiquem em pé, subam ou se pendurem em gavetas, portas ou prateleiras.
- NUNCA abra mais de uma gaveta ao mesmo tempo.
- Coloque os objetos mais pesados nas gavetas inferiores.
-

Informação permanente.
Não remova!



Serious or fatal crushing injuries can occur from the tipover.

To reduce the risk of furniture tipover:

- ALWAYS install tipover restraint provided.
- NEVER put a TV on this product.
- NEVER allow children to stand, climb or hang on drawers, doors or shelves.
- NEVER open more than one drawer at a time.
- Place heaviest items in the lowest drawers.

This is a permanent label.
Do not remove!



Riesgo de aplastamiento graves o fatales en caso de caídas de los muebles.

Para reducir el riesgo de que los muebles se vuelquen:

- Instale siempre el sistema antivuelco proporcionado.
- NUNCA instale una TELE en este producto.
- NUNCA permita que los niños se paren, trepen o cuelguen de cajones, puertas o estantes.
- NUNCA abra más de un cajón al mismo tiempo.
- Coloque los objetos más pesados en los cajones inferiores.

Información permanente.
¡No retires!