

MANUAL DE MONTAGEM

ASSEMBLY INSTRUCTIONS

INSTRUCCIONES DE MONTAJE

NOTICE DE MONTAGE

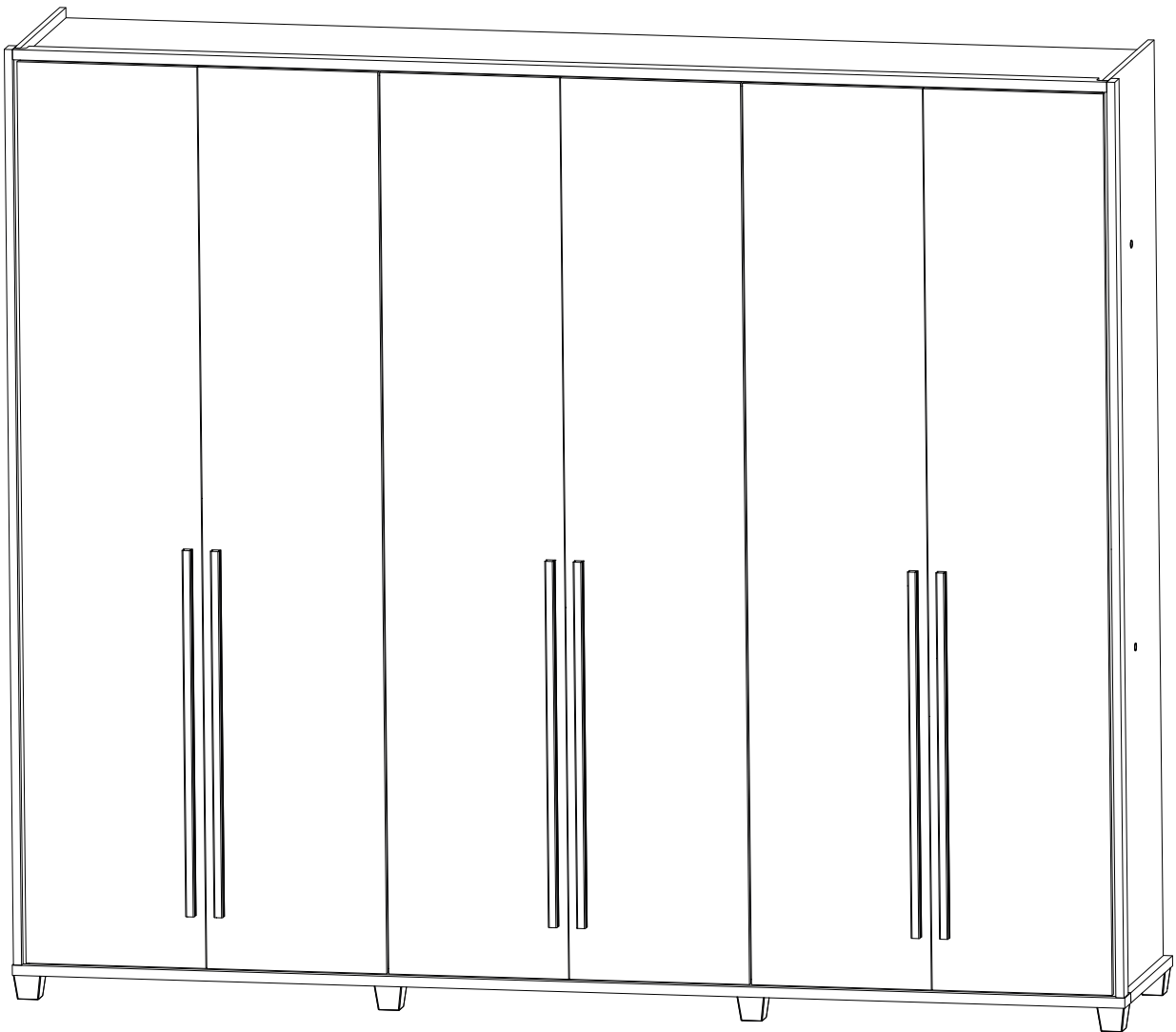

COD: 35900

REV. 00 - 25/03/24

OBSERVAÇÕES IMPORTANTES IMPORTANT REMARKS OBSERVACIONES IMPORTANTES REMARQUES IMPORTANTES



Nunca escale ou se apoie sobre o móvel. Você pode sofrer graves acidentes.

Never climb or lean on the furniture. You may suffer serious accidents.

Nunca escale o apoie sobre el mobiliario. Usted puede sufrir graves accidentes.

Ne montez jamais sur le meuble. Vous pourriez subir un grave accident.

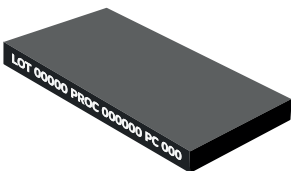

Observe os números impressos nas bordas para identificar as peças.

Identify the parts by observing the number printed on their edges.

Identifique las piezas observando el numero impreso en sus bordes.

Notez les numéros imprimés sur les bords pour identifier les pièces.



Movimente o móvel com cuidado, sem arrastar. Peça ajuda a outra pessoa para fazê-lo.

Move the piece carefully, don't drag it. Ask for someone else's help to do so.

Mover la unidad con cuidado, sin arrastar. Pedir ayuda da otra persona para moverlo.

Déplacez les meubles avec précaution sans le faire glisser. Demandez a quelqu'un de vous aider à le faire.



Utilize a embalagem para forrar a área de montagem e separar todas as peças.

Use the packaging to cover the assembly area and separate all parts.

Utilice el embalaje para cubrir la area de montaje y separe las piezas.

Couvrez la zone d'assemblage avec l'emballage pour séparer le pièces.



Limpe com um pano limpo e umedecido em água e sabão neutro. Não utilizar produtos químicos e abrasivos.

Wipe clean using a damp cloth and a mild cleaner. Don't use abrasive and chemical products.

Limpie con un paño limpiohumedecido con agua y jabón neutro. No utilice productos químicos y abrasivos.

Nettoyez avec un chiffon propre imbibé avec d'eau et de savon doux. N'utilisez pas de produits chimiques et abrasifs.



Não colocar objetos em alta temperatura diretamente sobre superfícies de vidro.

Do not place high-temperature objects directly on glass surfaces.

No coloque objetos de alta temperatura directamente sobre superficies de vidro.

Ne placez pas d'objets à haute température directment sur les surfaces en verre.

ACESSÓRIOS HARDWARE HERRAJES ACCESSOIRES

Identifique e separe os acessórios utilizados. Em cada embalagem, uma etiqueta identifica as peças e onde utilizá-las.

Identify and separate the hardware used in the assembly. There's a label on each package identifying the parts and where to use them.

Identifique y separete los accesorios utilizados en el montaje. Observe la etiqueta en cada paquete para saber donde montar.



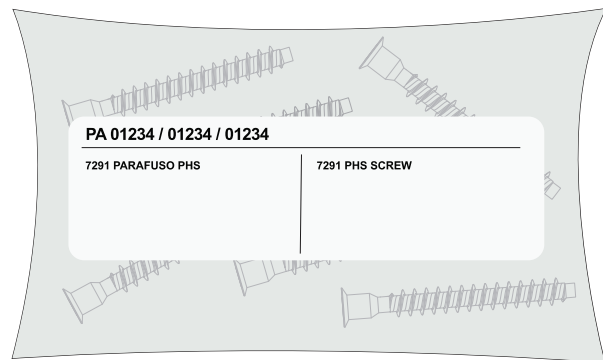





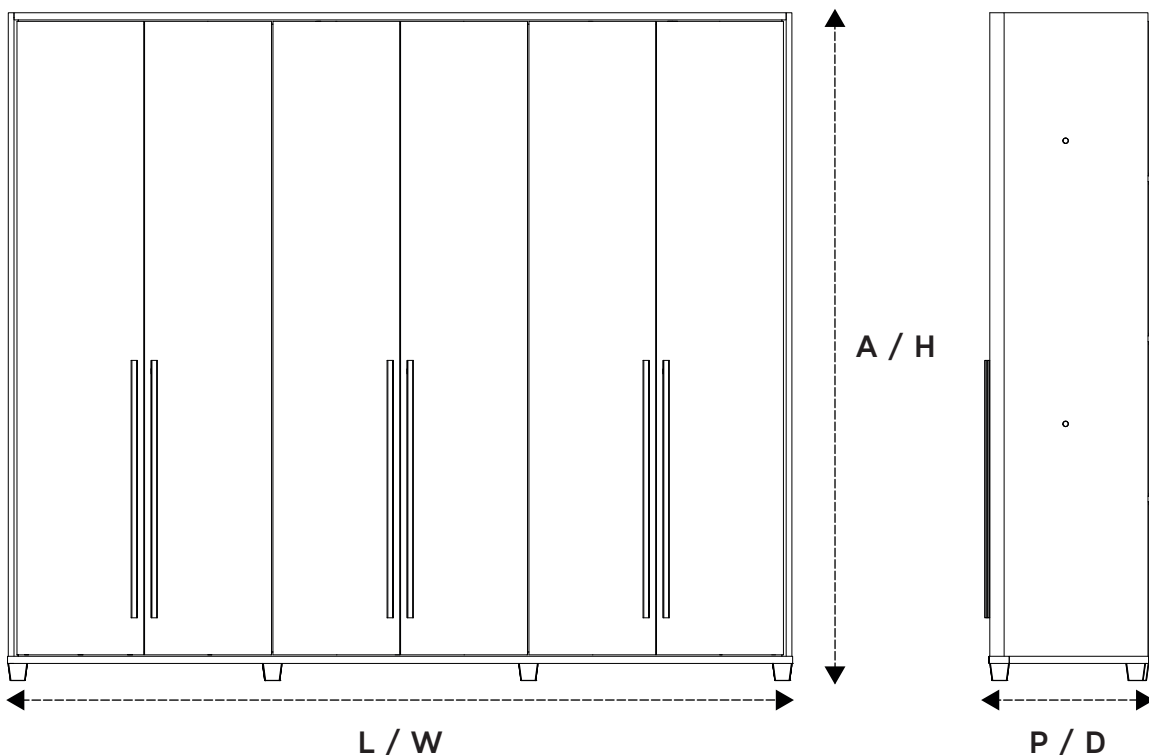

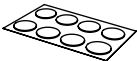



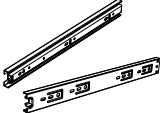
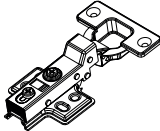

Identifiez et séparez les accessoires à être utilisés. Dans chaque emballage il y a une étiquette pour identifier les pièces et où les utiliser.

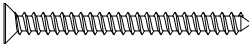

2745 mm

L:2745mm A:2335mm P:583mm
W:108.09in H:91.93in D:22.96in

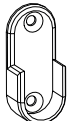

<p>A ADESIVO STICKER ADHESIVO AUTOCOLLANT (83X)</p> 	<p>B COD. 1669 (04X)</p> 	<p>C COD. 0138 (24X)</p> 	<p>D COD. 10063 (38X)</p> 	<p>E COD. 1668 6.0 x 30 (101X)</p> 
<p>F COD. 0342 (32X)</p> 	<p>G COD. 2661 (06X)</p> 	<p>H COD. 7349 (27X)</p> 	<p>I PÉ DE PLÁSTICO PLASTIC FOOT PIE DE PLÁSTICO PIED EN PLASTIQUE (08X)</p> 	<p>J COD. 0599 (38X)</p> 
<p>K COD. 0996 3.5 X 25 (02X)</p> 	<p>L COD. 1533 4.0 x 14 (68X)</p> 	<p>M COD. 7519 4.5 x 16 (188X)</p> 	<p>N COD. 0714 4.5 x 30 (79X)</p> 	<p>O COD. 0715 4.5 x 50 (26X)</p> 
<p>P COD. 0357 10 x 10 (120X)</p> 	<p>Q PUXADOR DOOR HANDLE MANIJA POIGNÉE GRIFF (01X)</p> 	<p>R COD. 0394 (06X)</p> 	<p>S COD. 16815 (01X)</p> 	<p>T COD. 16787 (02X)</p> 

MONTAGEM NECESSITA 2 PESSOAS
ASSEMBLY REQUIRES 2 PEOPLE
EL MONTAJE NECESITA 2 PERSONAS
MONTAGE A 2 PERSONNES

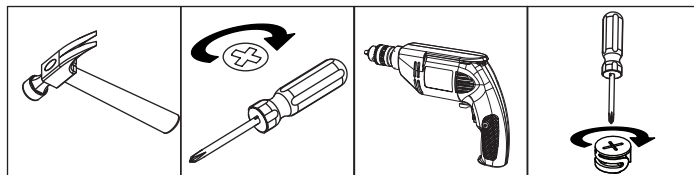



DESCRIÇÃO/ DESCRIPTION/ DESCRIPCIÓN/ DESCRIPTION

COD: 35900

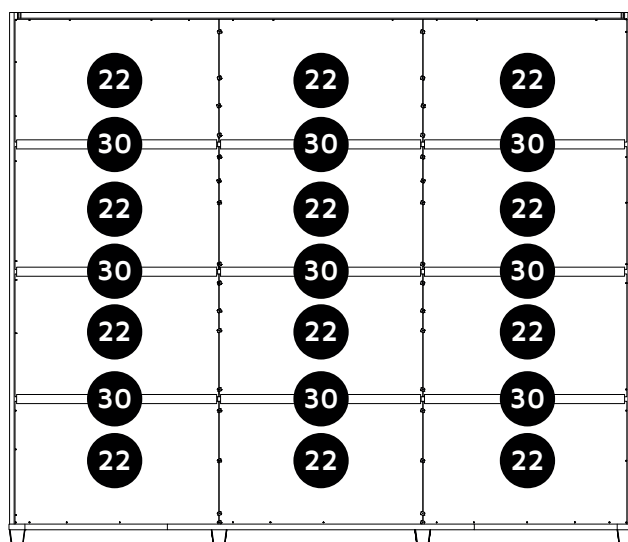
PEÇA PART PIEZA PIÈCE	QUANTIDADE QUANTITY CANTIDAD QUANTITÉ	DESCRIÇÃO	DESCRIPTION	DESCRIPCIÓN	DESCRIPTION	CAIXA BOX CAJA BOÎTE
01	01	BASE	BASE	BASE	BASE	03
02	01	CHAPÉU	TOP PANEL	PANEL SUPERIOR	PLATEAU	03
03	01	LATERAL ESQUERDA	LEFT SIDE	LATERAL IZQUIERDA	CÔTÉ GAUCHE	04
04	01	LATERAL DIREITA	RIGHT SIDE	LATERAL DERECHA	CÔTÉ DROITE	04
05	01	DIVISÓRIA ESQUERDA	LEFT DIVIDER	DIVISION IZQUIERDA	DIVISEUR GAUCHE	05
06	01	DIVISÓRIA DIREITA	RIGHT DIVIDER	DIVISION DERECHA	DIVISEUR DROITE	05
07	01	DIVISÓRIA CENTRAL	CENER DIVIDER	DIVISION CENTRAL	DIVISEUR CENTRALE	05
08	02	PRATELEIRA SUPERIOR	UPPER SHELF	ESTANTE SUPERIOR	ÉTAGÈRE SUPÉRIEURES	06
09	01	PRATELEIRA CENTRAL SUP.	UPPER CENTER SHELF	ESTANTE CENTRAL SUP.	ÉTAGÈRE SUPÉRIEURES	03
10	02	RODAPÉ LATERAL	SIDE BATTEN	SOPORTE LATERAL	PLINTHE LATÉRALE	07
11	02	PRATELEIRA INFERIOR	LOWER SHELF	ESTANTE INFERIOR	ÉTAGÈRE INFÉRIEURES	03
13	04	PRATELEIRA CENTRAL	CENTER SHELF	ESTANTE CENTRAL	ÉTAGÈRE CENTRALE	05
14	01	SARRAFO INTERNO	INNER BATTEN	SARRAFO INTERNO	LATTE INTERNE	04
15	01	RODAPÉ FRONTAL	FRONT LOWER BATTEN	SOPORTE FRONTAL	PLINTHE AVANT	07
16	02	MOLDURA LATERAL	SIDE FRAME	CUADRO LATERAL	CADRE LATÉRALE	07
17	01	MOLDURA SUPERIOR	UPPER FRAME	CUADRO SUPERIOR	CADRE SUPÉRIEURES	07
18	01	RODAPÉ TRASEIRO	BACKSIDELOWER BATTEN	SOPORTE TRASERO	PLINTHE ARRIÈRE	07
19	01	PORTA INTERNA	INNER DOOR	PUERTA INTERNA	PORTE INTERNE	04
20	06	PORTA	DOOR	PUERTA	PORTE	01/02
22	12	FUNDO	BACKPLATE	FONDO	FOND	05
25	04	DISTANCIADOR	DISTANCER	DISTANCIADOR	DISTANCEUR	04
30	09	PERFIL H	H-PROFILE	PERFIL EN H	PROFILÉ EN H	05
32	04	DISTANCIADOR	DISTANCER	DISTANCIADOR	DISTANCEUR	04
33	06	PUXADOR	DOOR HANDLE	MANIJA DE PUERTA	POIGNÉE DE PORTE	04
60	06	FRENTE GAVETA	DRAWER FRONT	FRENTE DEL CAJÓN	FAÇADE DE TIROIR	06
61	06	LATERAL GAVETA ESQ.	LEFT DRAWER SIDE	CAJÓN LATERAL IZQ.	CÔTÉ DE TIROIR	06
62	06	LATERAL GAVETA DIR.	RIGHT DRAWER SIDE	CAJÓN LATERAL DER.	CÔTÉ DE TIROIR	06
63	06	CONTRA FUNDO	DRAWER BACK PANEL	CAJÓN INFERIOR	DERRIÈRE	06
64	06	FUNDO GAVETA	DRAWER BOTTOM	FONDO DEL CAJÓN	FOND DE TIROIR	06

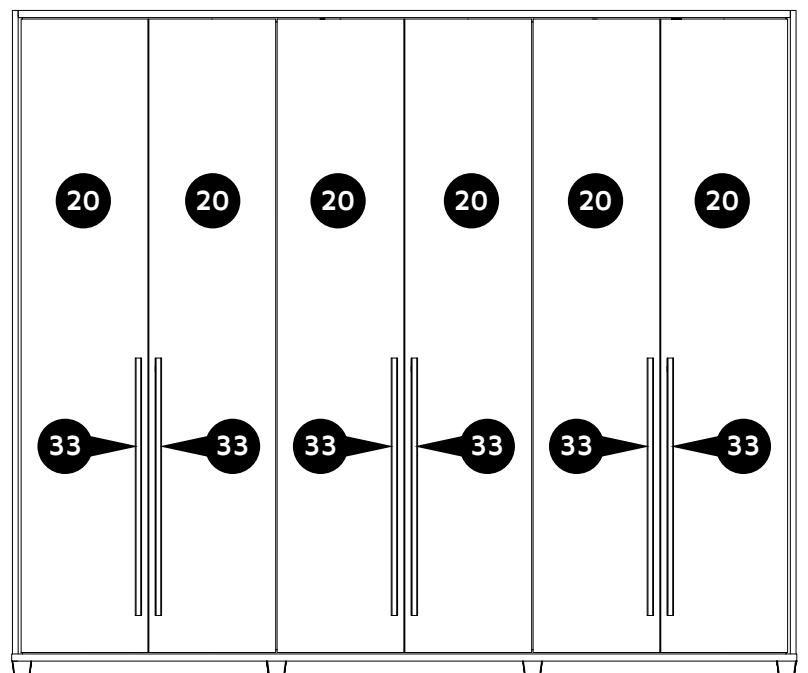
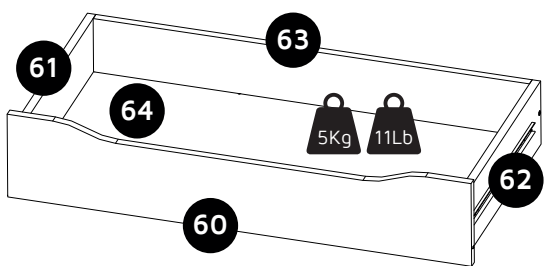
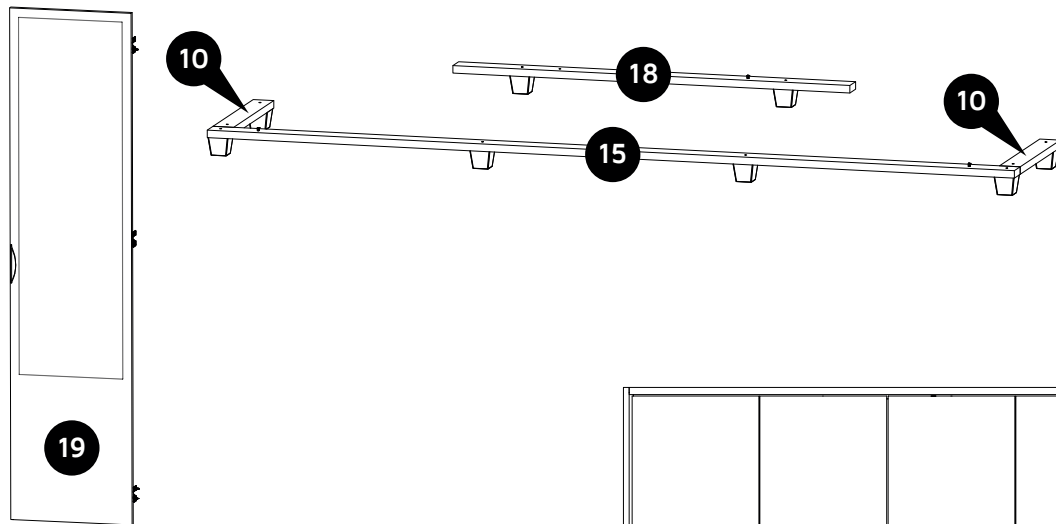
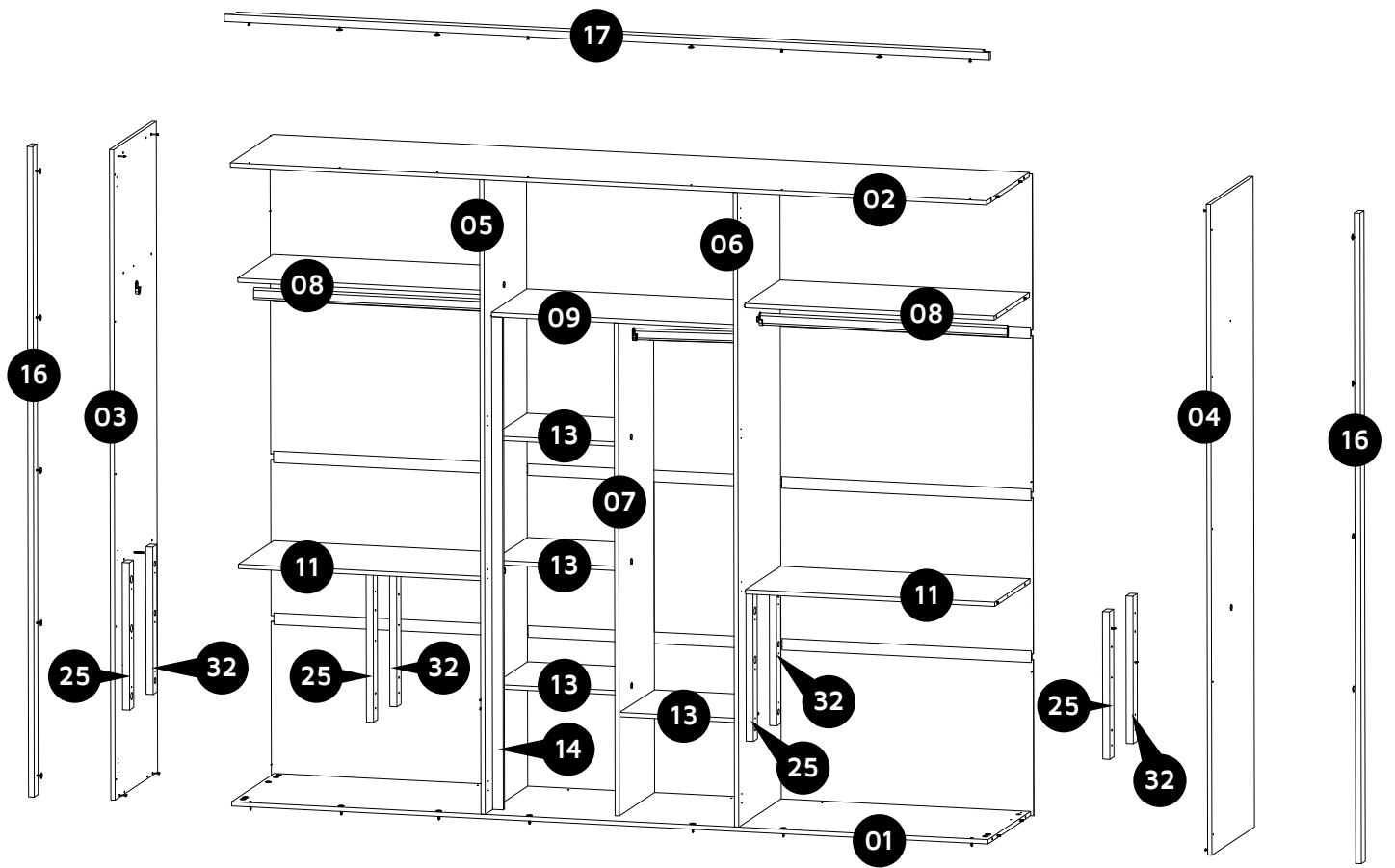



01

A 	E COD. 1668 	G COD. 2661 	I 	J COD. 0599 	L COD. 1533 	M COD. 7519 	N COD. 0714 	R COD. 0394
--------------	---------------------------	---------------------------	--------------	---------------------------	---------------------------	---------------------------	---------------------------	---------------------------

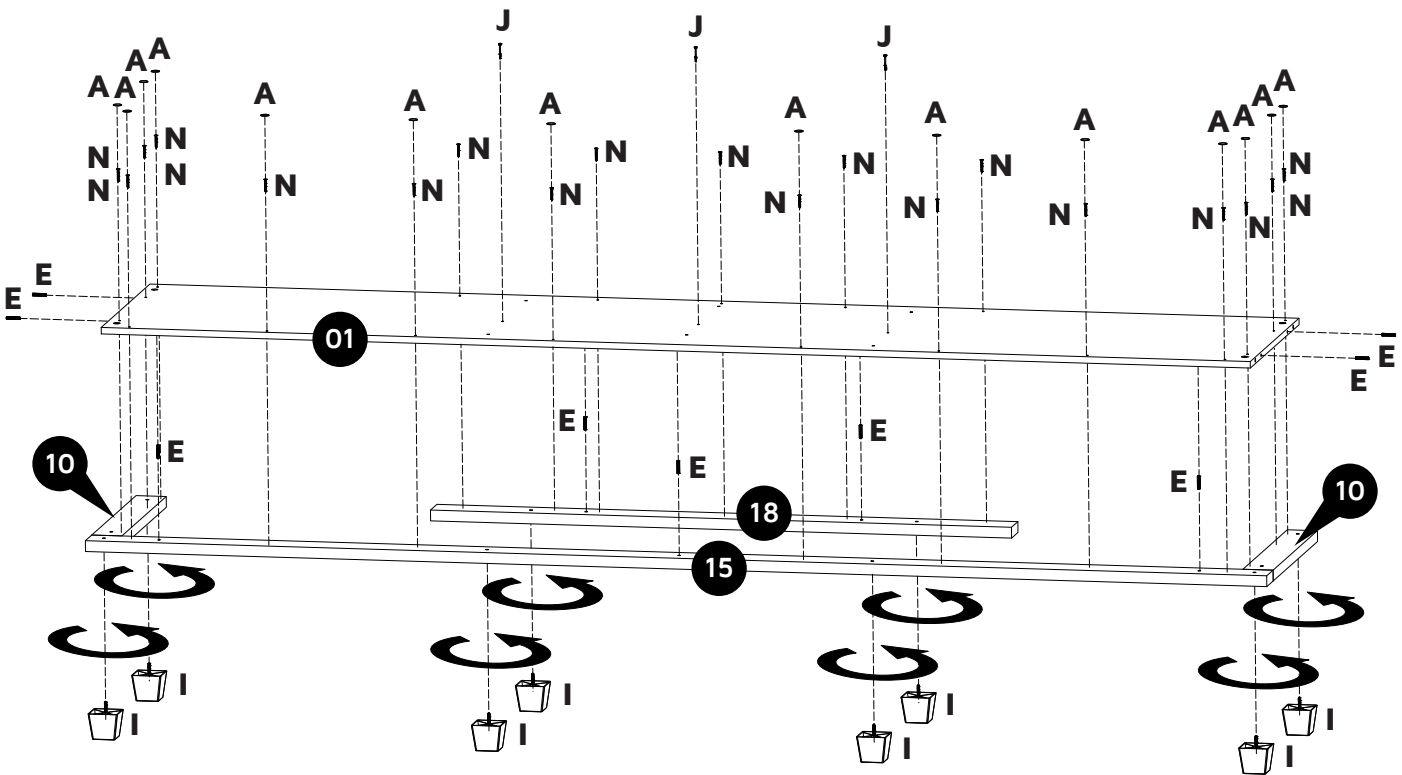

02

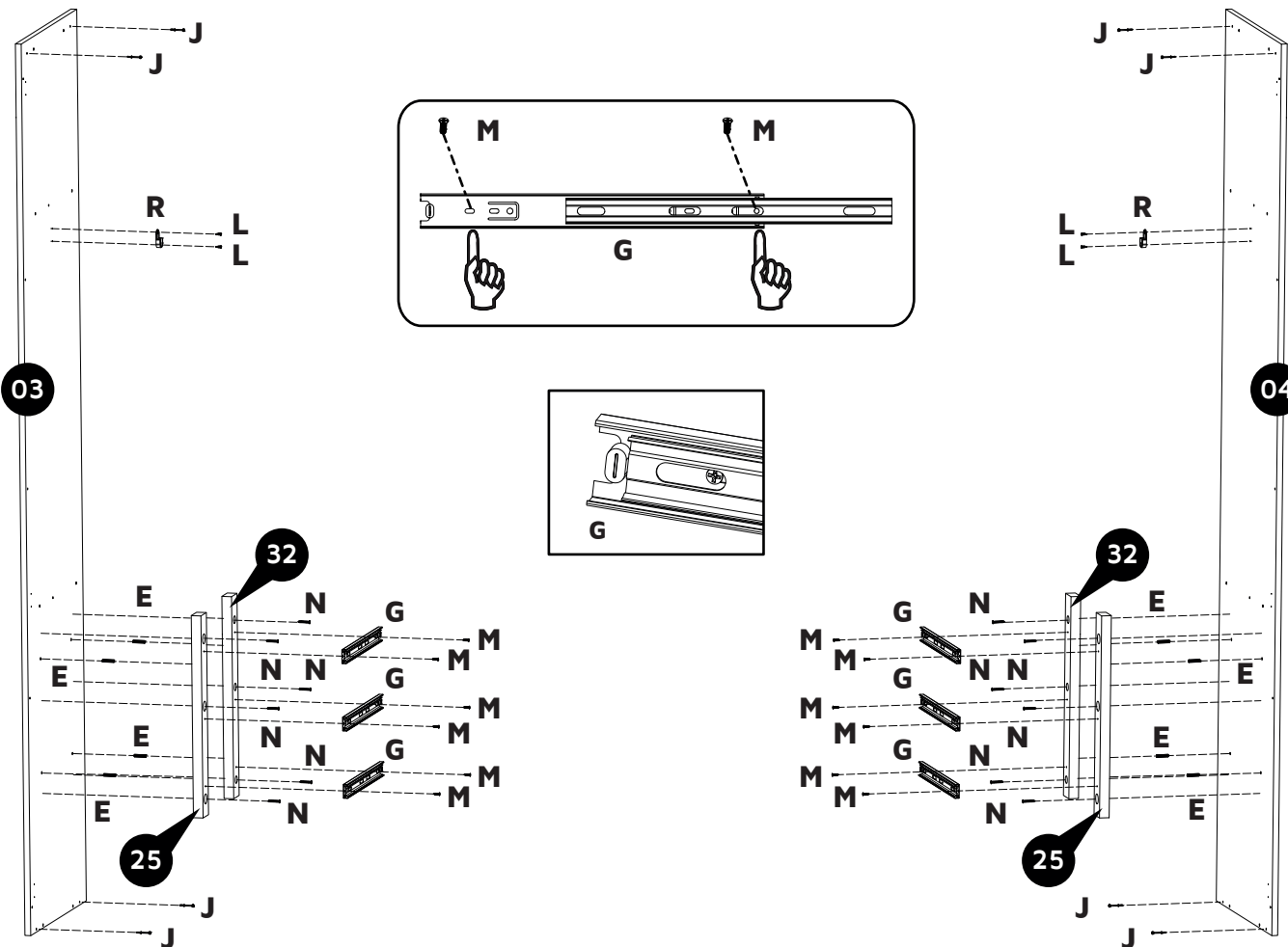

03



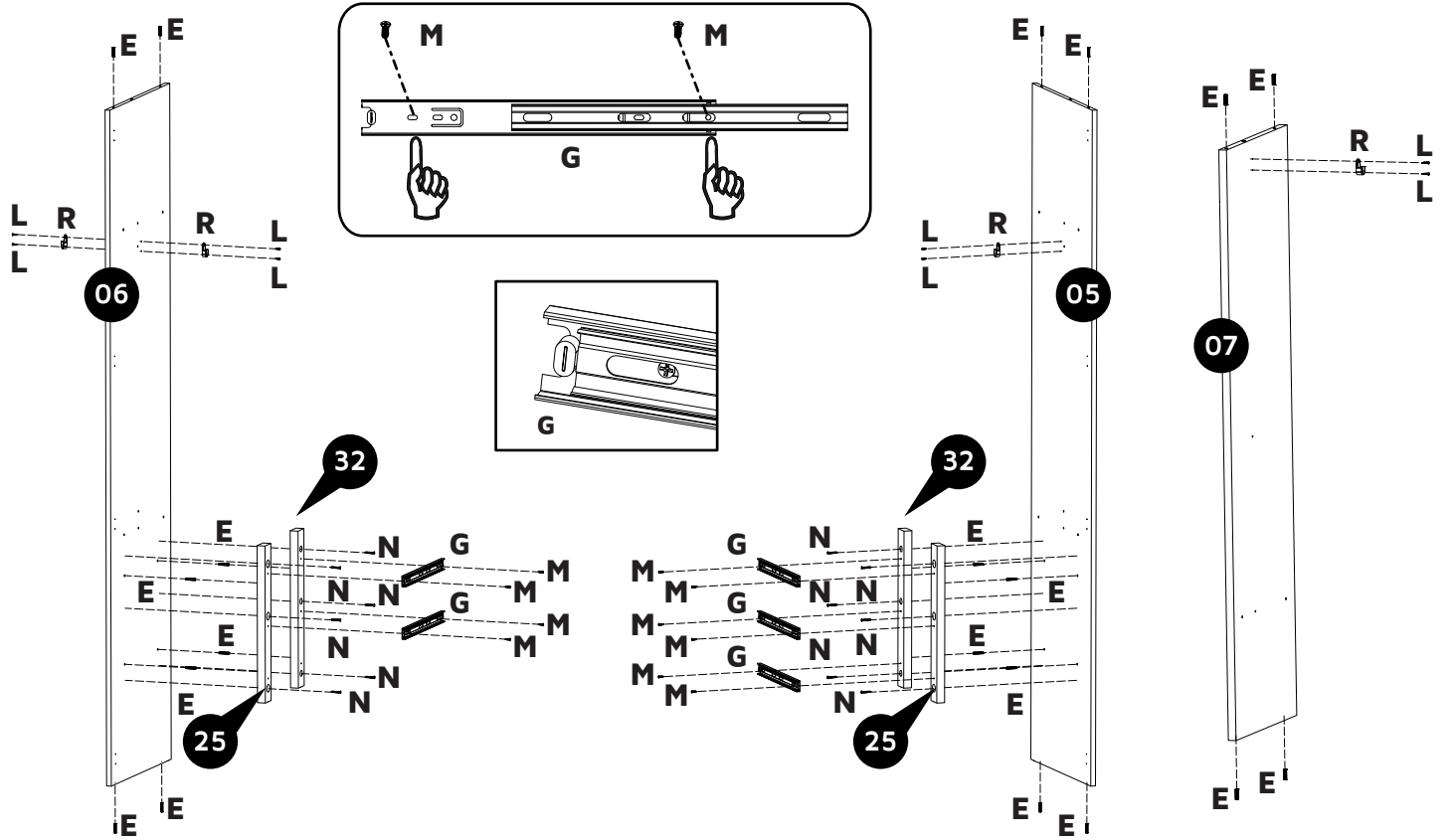



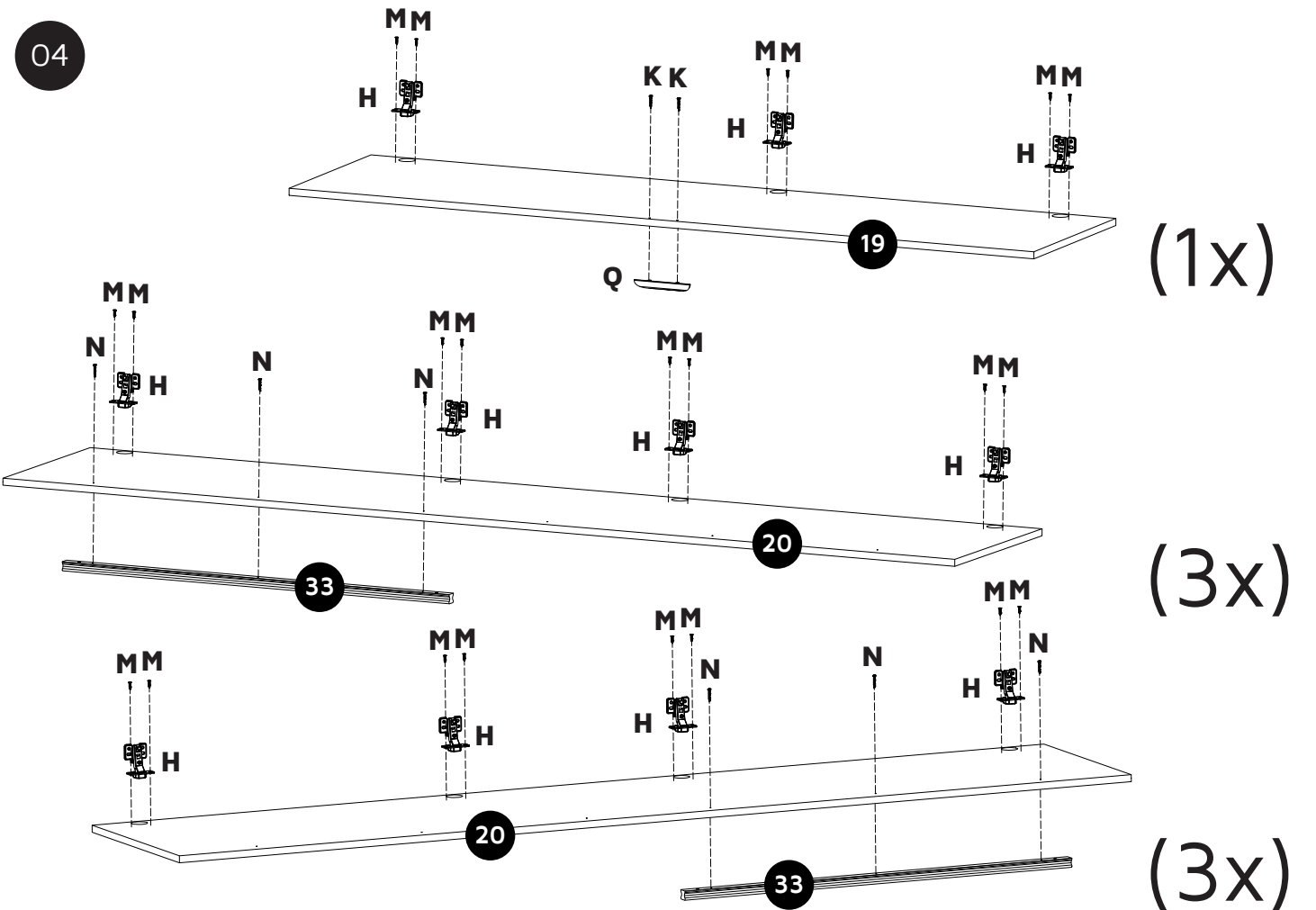

E COD. 1668	G COD. 2661	H COD. 7349	K COD. 0996	L COD. 1533	M COD. 7519	N COD. 0714	Q	R COD. 0394

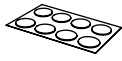

04



05

A 	C COD. 0138 	D COD. 10063 	E COD. 1668 	G COD. 2661 	J COD. 0599 	L COD. 1533 	O COD. 0715 
---	--	---	--	--	--	--	--

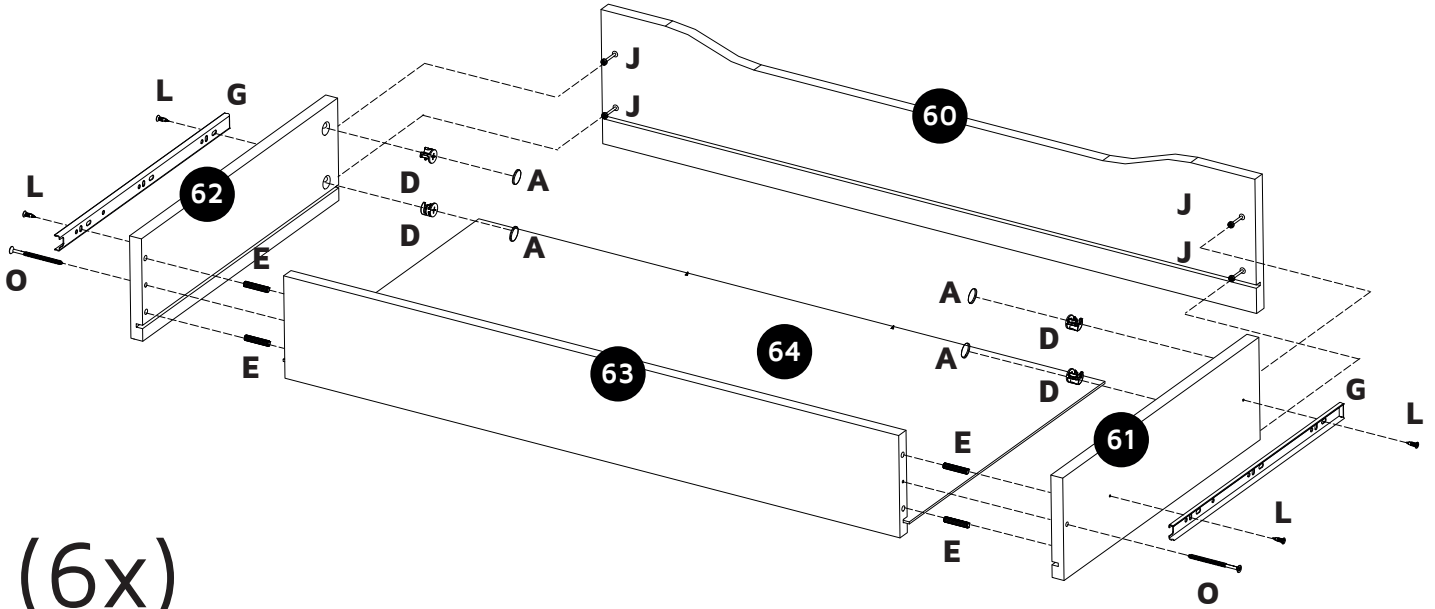
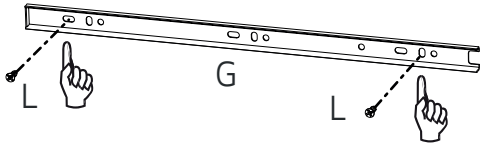





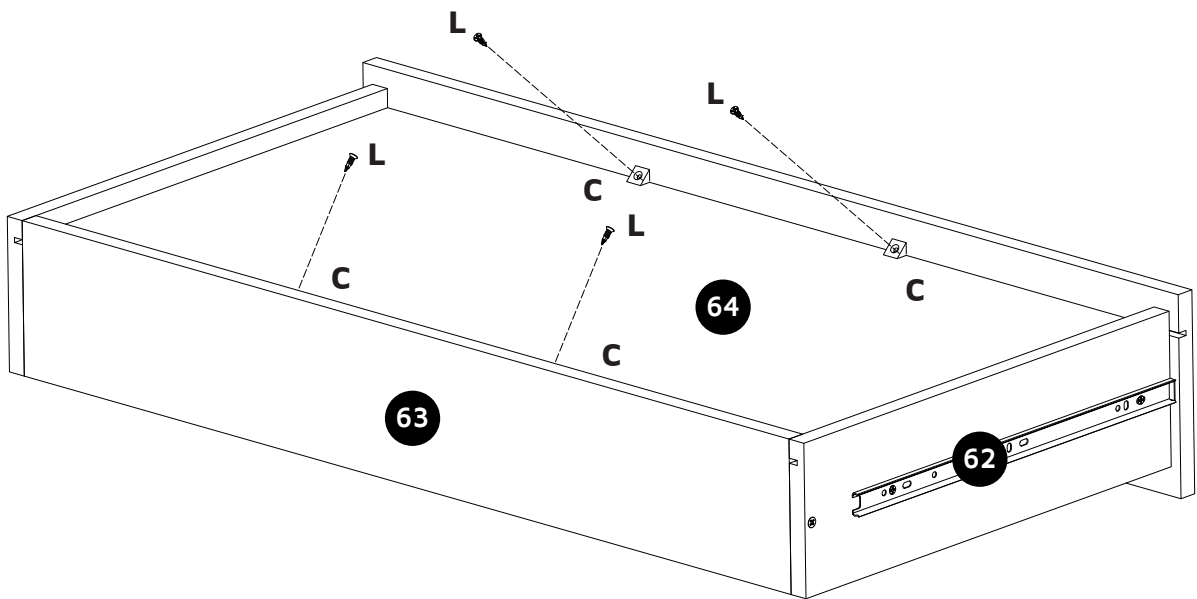

(6x)

06

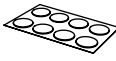

(6x)

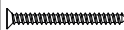
07



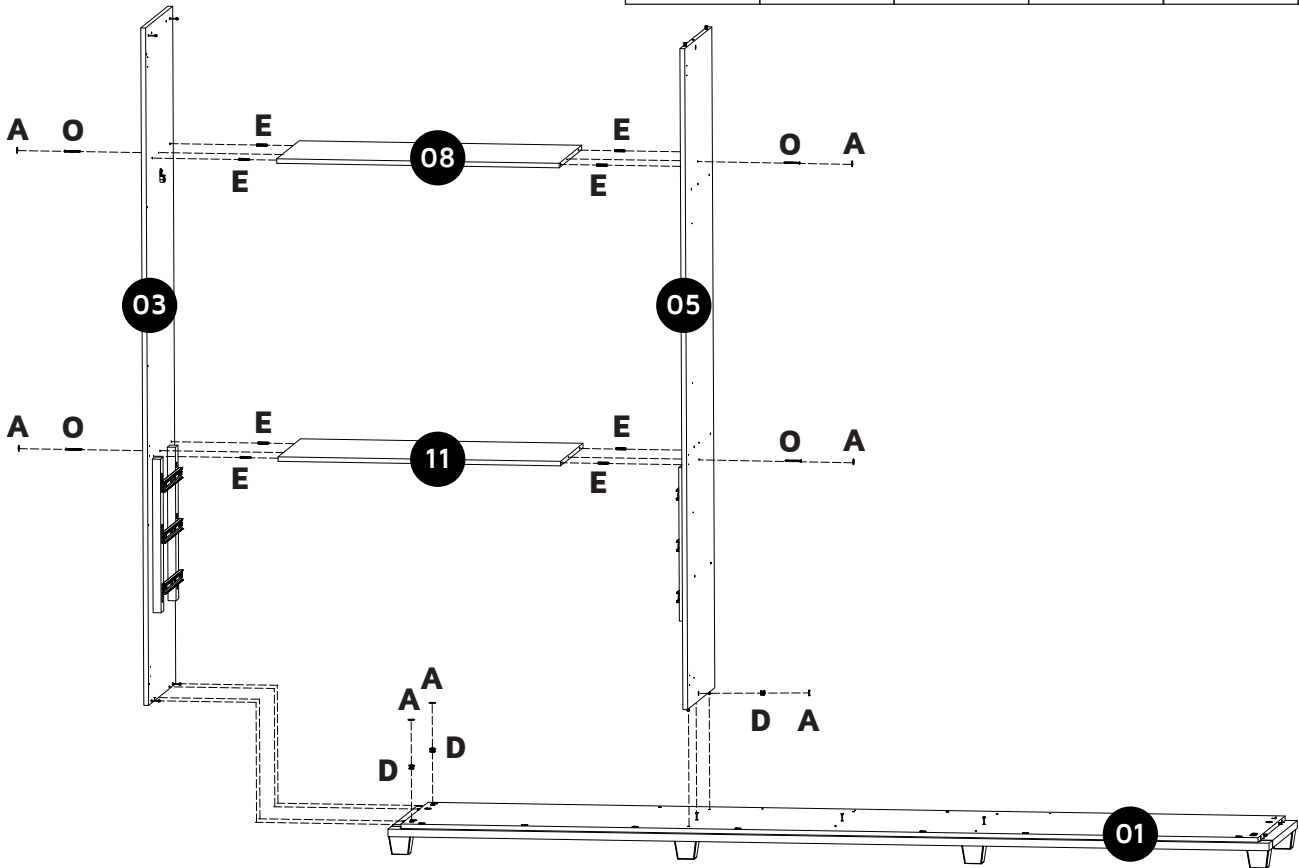

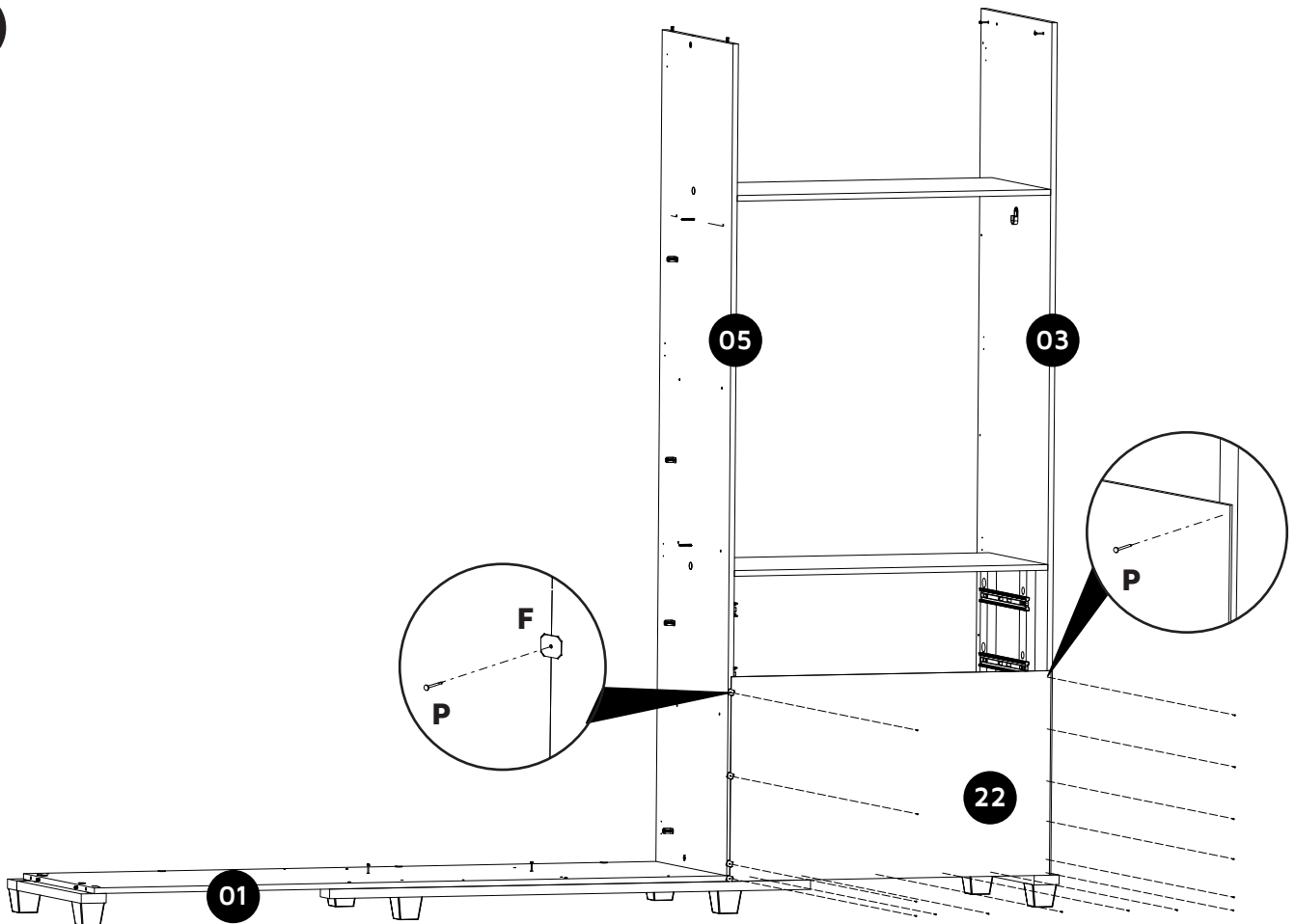

A 	D COD. 10063 	E COD. 1668 	F COD. 0342 	O COD. 0715 	P COD. 0357 
---	---	---	--	--	--



08



09



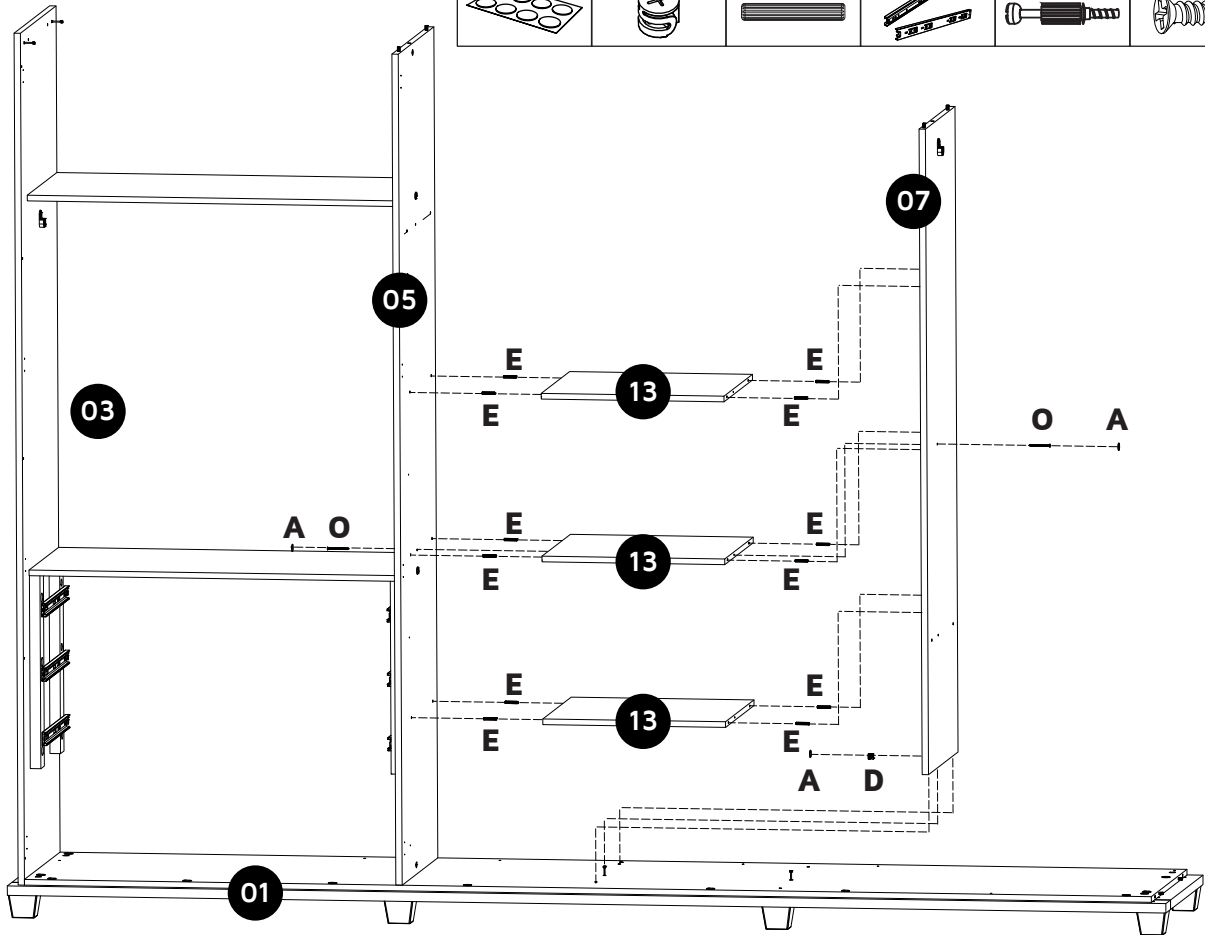

A 	D COD. 10063 	E COD. 1668 	G COD. 2661 	J COD. 0599 	M COD. 7519 	O COD. 0715 
---	---	--	---	--	--	--

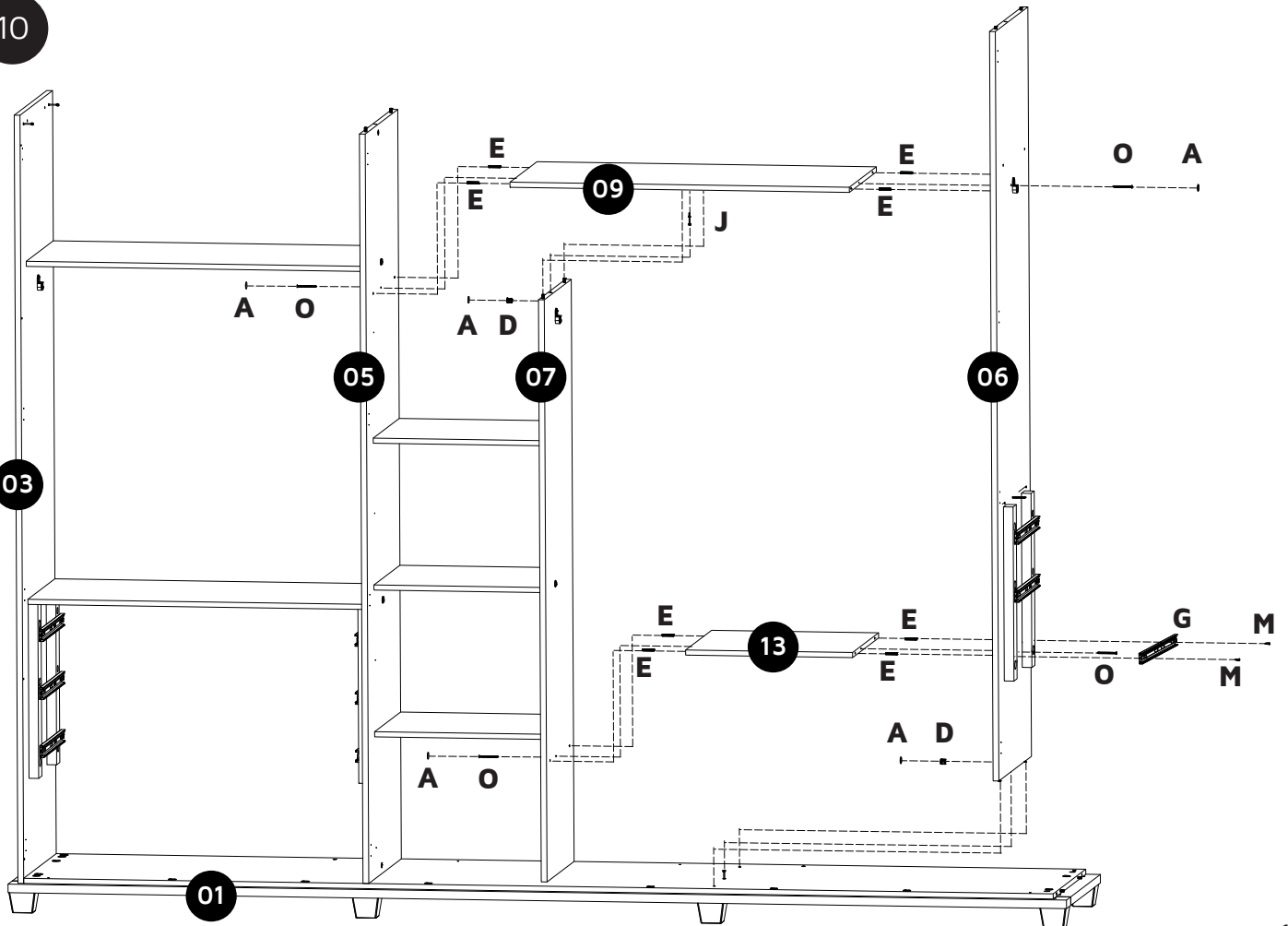

10

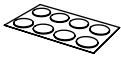

11



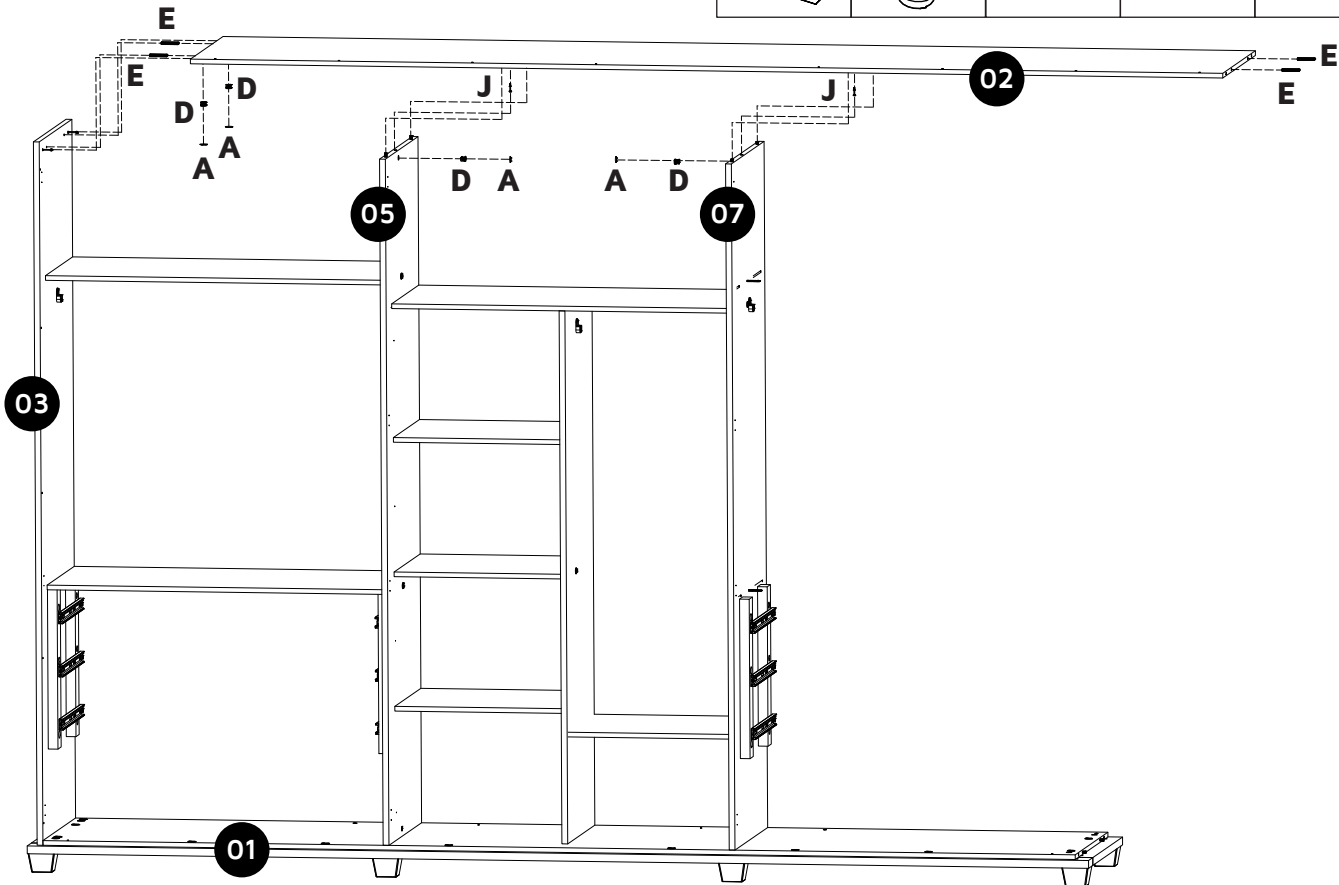

A 	D COD. 10063 	E COD. 1668 	J COD. 0599 	O COD. 0715 
---	---	--	--	--

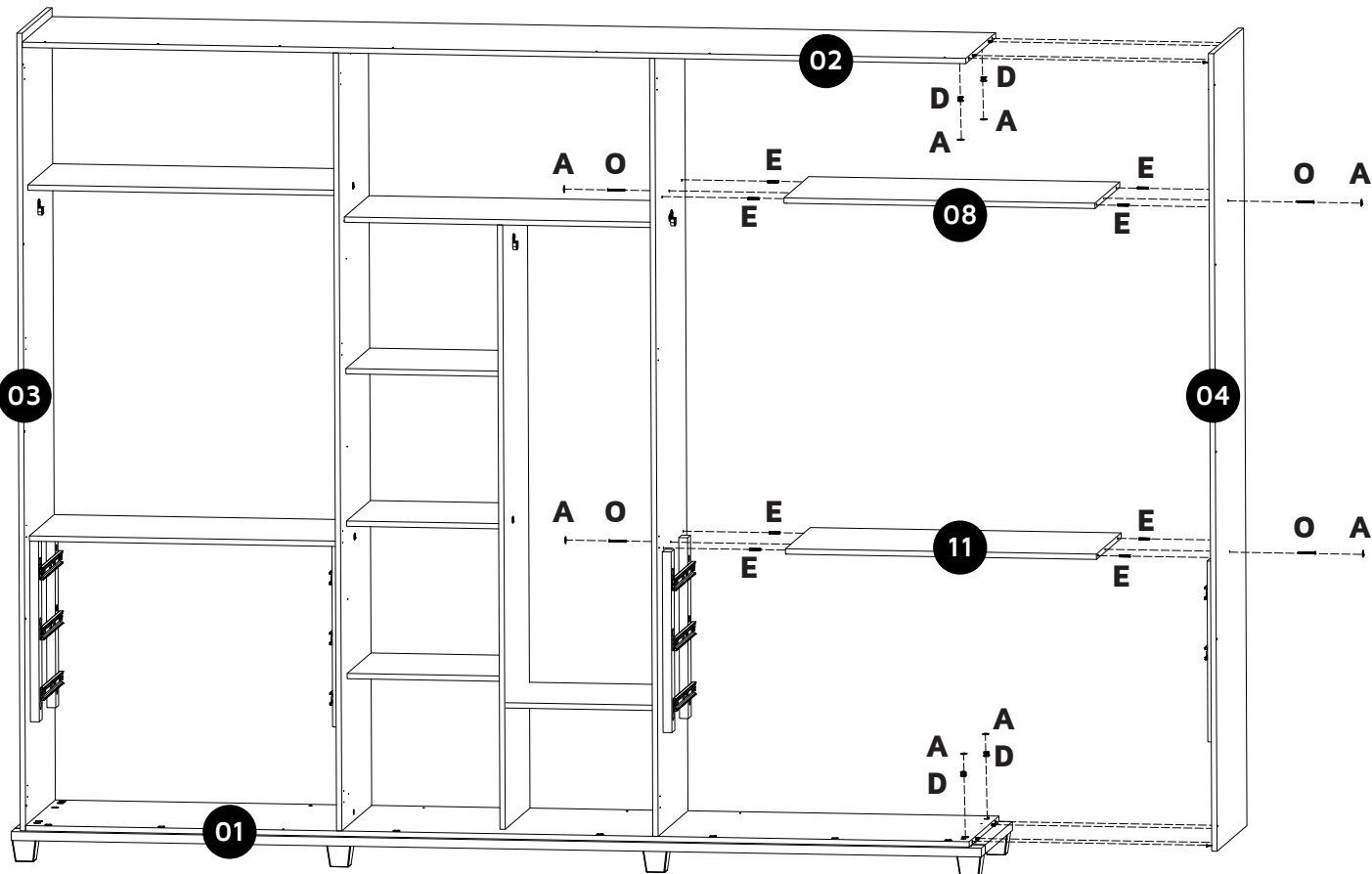

12

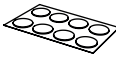

13



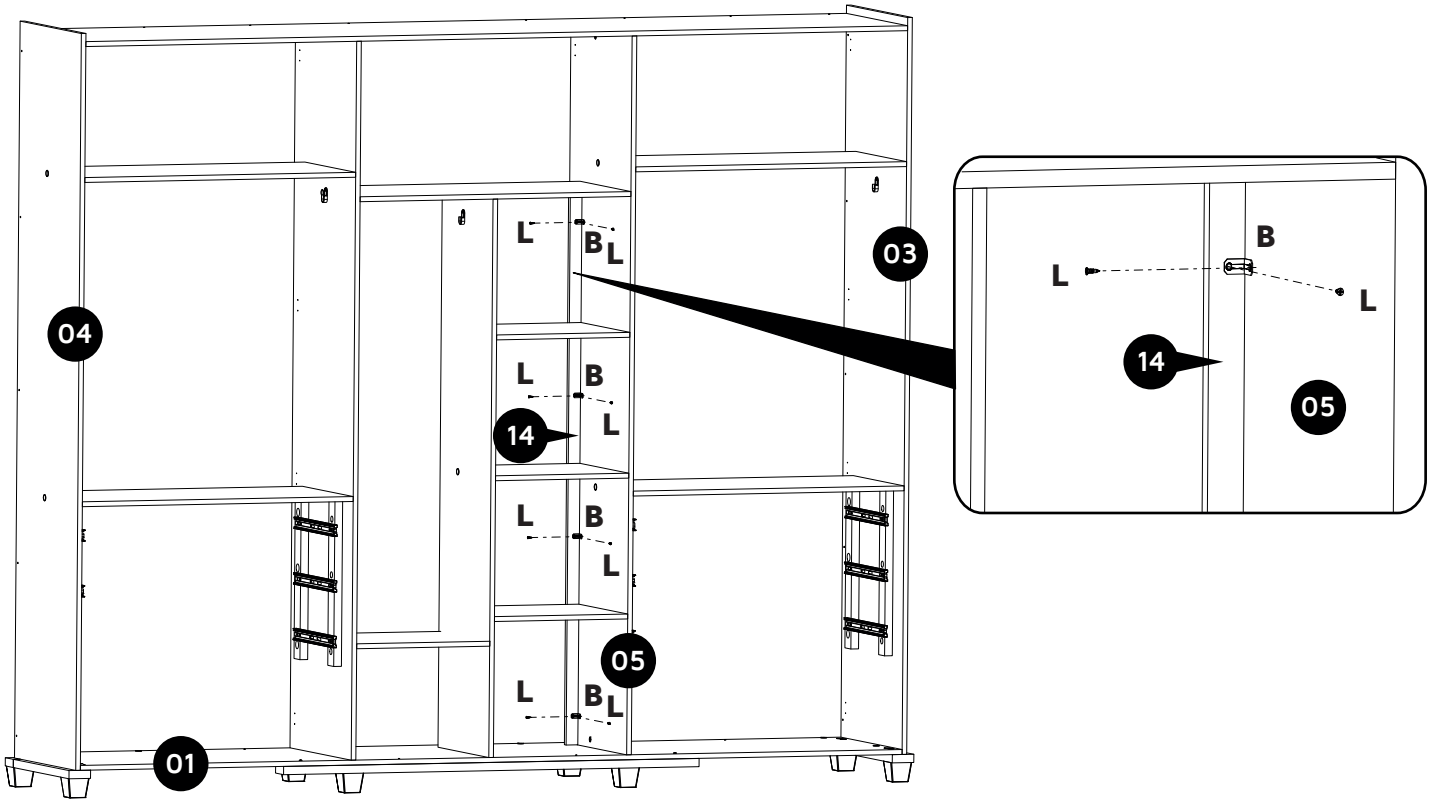

A 	B COD. 1669 	L COD. 1533 	N COD. 0714 
--	--	--	--

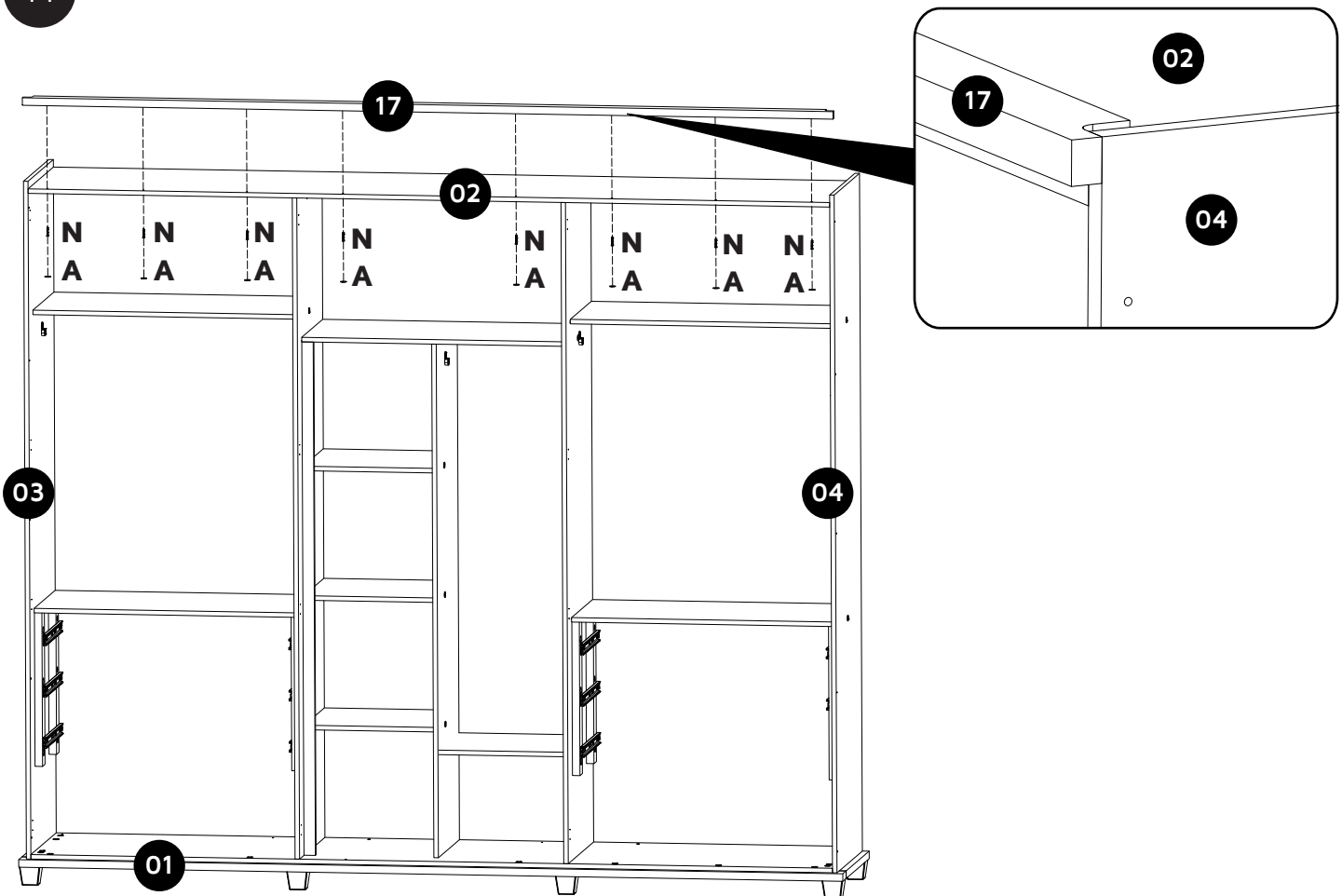

14

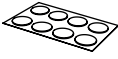

15

A 	F COD. 0342 	N COD. 0714 	P COD. 0357 
--	--	--	--

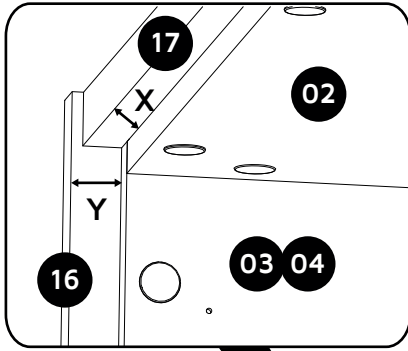

X = 18mm
00.709 inches

Y = 19mm
00.748 inches



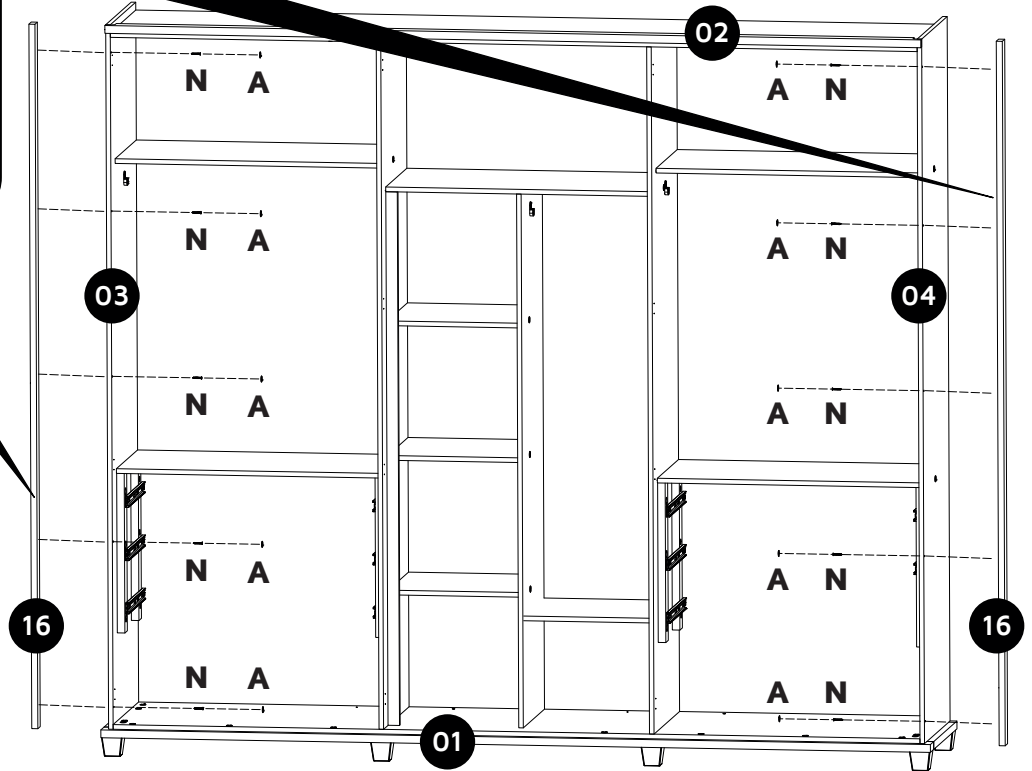

Atenção
Attention
Atención
Attention

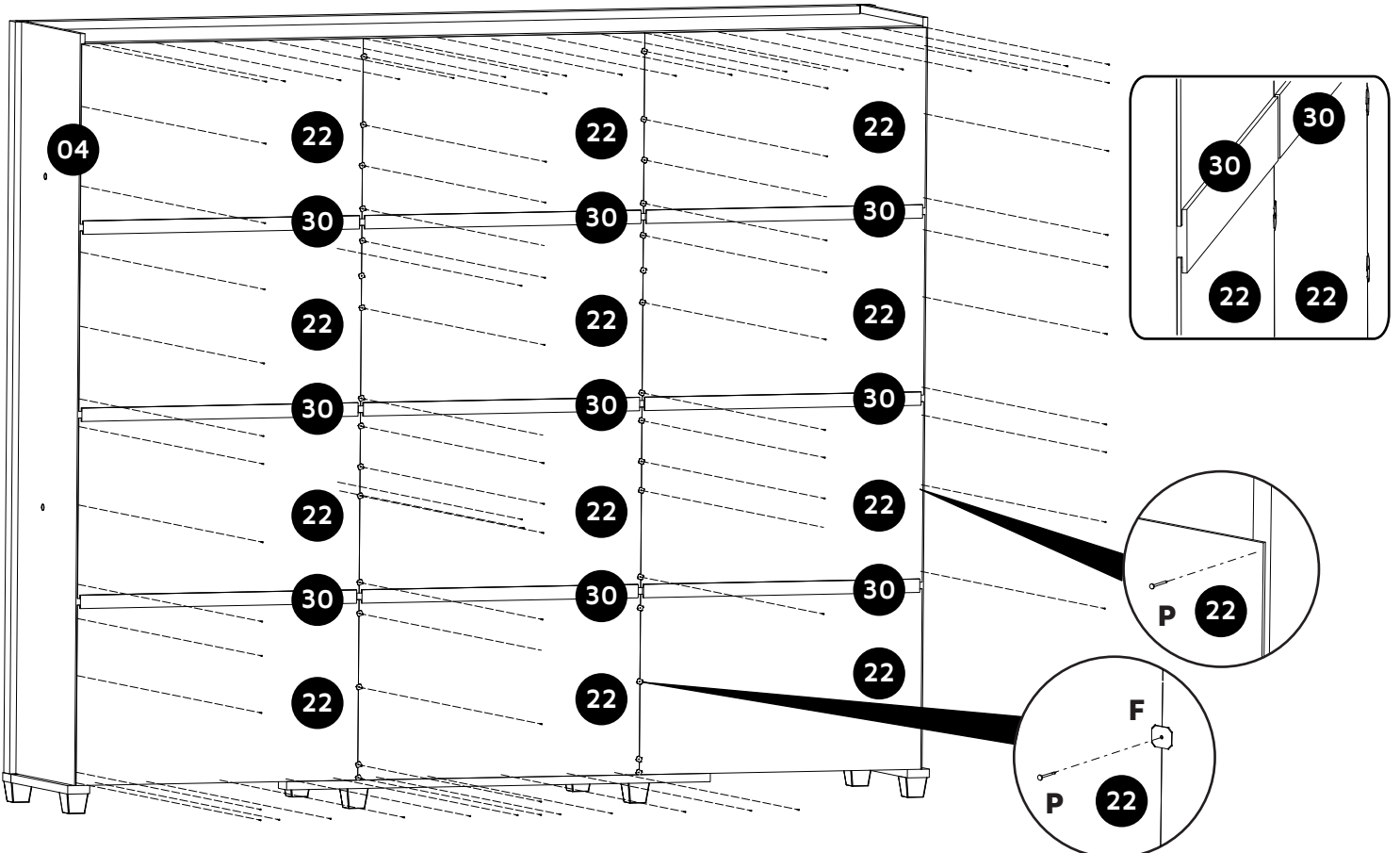

16



17

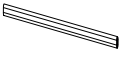
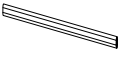

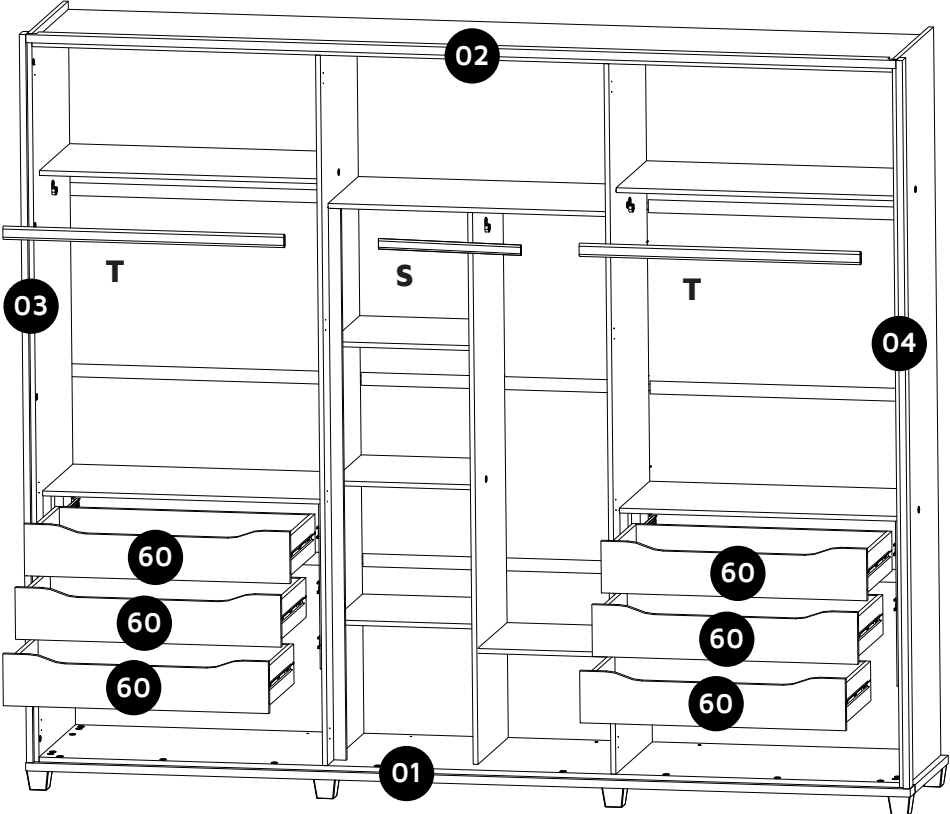
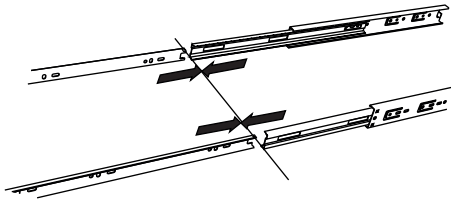
H COD. 7349 	M COD. 7519 	S COD. 16815 	T COD. 16787 
--	--	---	---

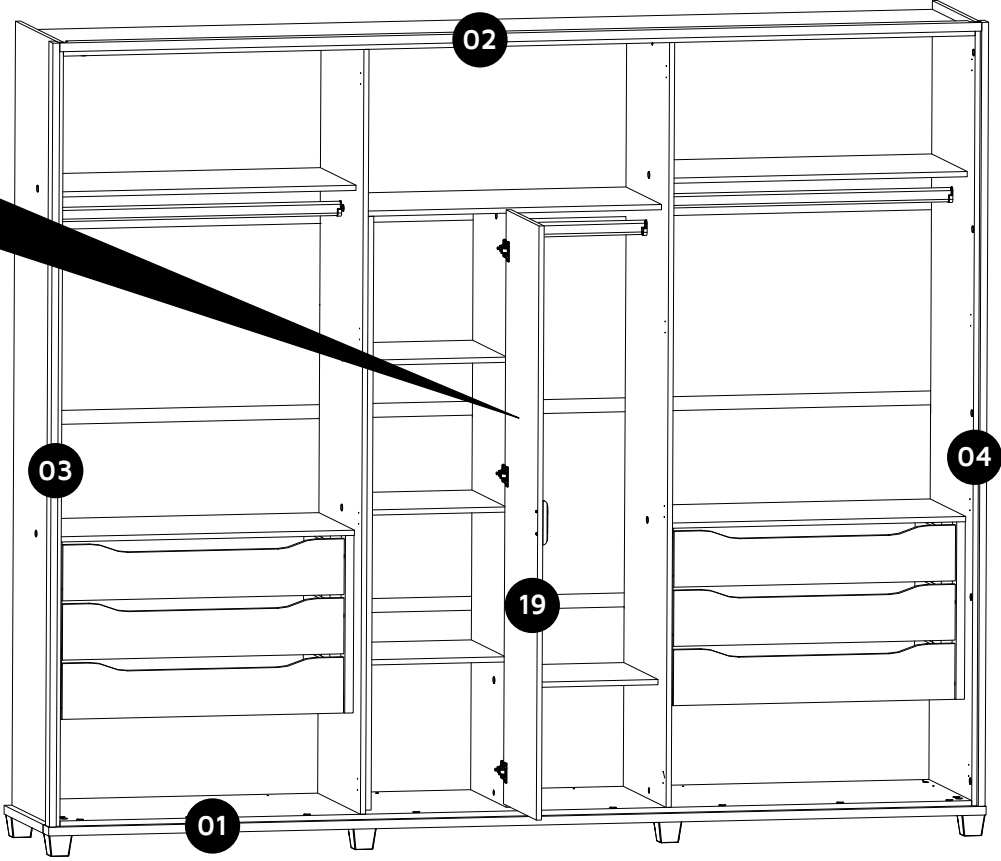
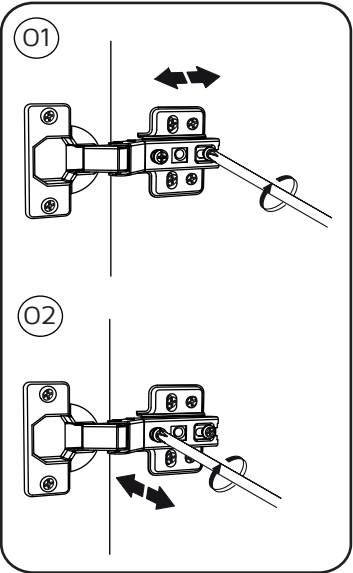
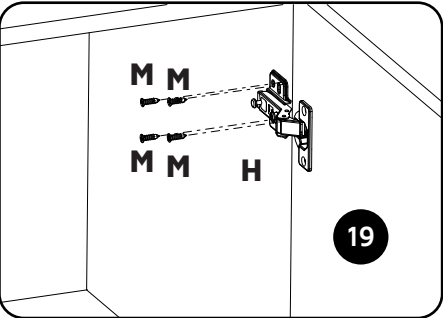

18



19

H COD. 7349	M COD. 7519
	

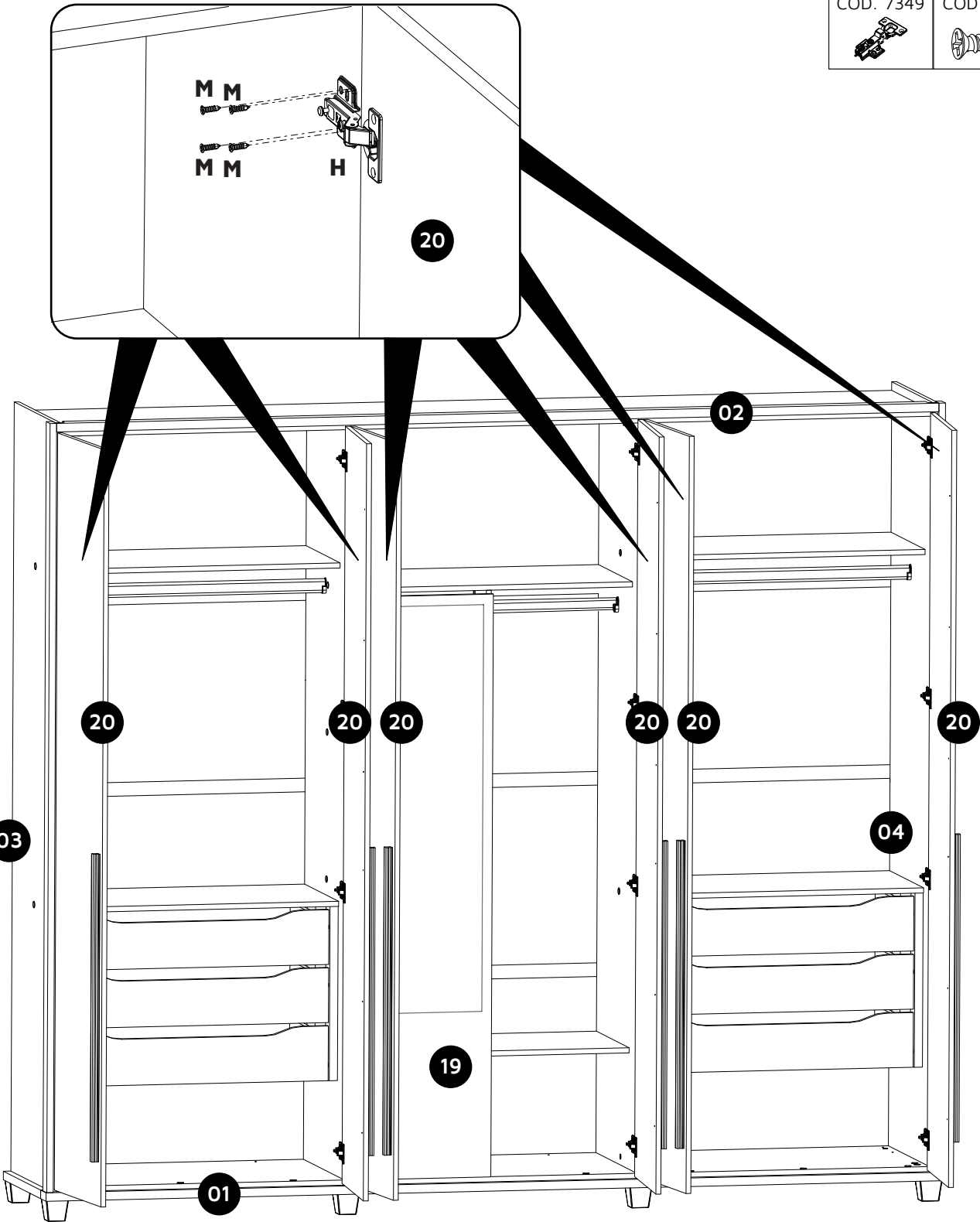

AJUSTE DAS DOBRADIÇAS
HINGE ADJUSTMENT
AJUSTE DE LAS BISAGRAS
RÉGLAGE DES CHARNIÈRES

