

N°	CÓDIGO CODE CÓDIGO	DESCRIÇÃO DESCRIPTION DESCRIPCIÓN	DIMENSÃO (mm) DIMENSION (mm) DIMENSION (mm)			QUANTIDADE QUANTITY CANTIDAD
			COMP. LEN. LON.	LARG. WID. ANC.	EPS DEP ESP	
1	65962	FECHAMENTO INFERIOR MAIOR/ BIG LOWER CLOSURE/ CIERRE INFERIOR GRANDE	1000	80	15	1
2	65963	FECHAMENTO INFERIOR MENOR/ SMALL LOWER CLOSURE/ CIERRE INFERIOR PEQUENA	225	80	15	2
3	65964	LATERAL MAIOR/ BIG SIDE/ LATERAL GRANDE	720	459	15	2
4	65967	PAINEL FECHAMENTO COM FURO/ CLOSING PANEL WITH HOLE/ PANEL DE CIERRE CON AGUJERO	720	528	15	1
5	65968	PAINEL FECHAMENTO SEM FURO/ CLOSING PANEL WITHOUT HOLE/ PANEL DE CIERRE SIN AGUJERO	720	528	15	1
6	65969	FECHAMENTO VERTICAL/ VERTICAL CLOSURE/ CIERRE VERTICAL	720	59	15	3
7	65972	TRAVESSA/ BATTEN/ TRAVIESA	720	70	25	3
8	65975	LATERAL MENOR/ SMALL SIDE/ LATERAL PEQUENA	720	227	15	2
9	65977	FECHAMENTO VERTICAL DA LATERAL MENOR/ VERTICAL CLOSURE OF THE SMALL SIDE/ CIERRE VERTICAL DE LA LATERAL PEQUENA	720	59	15	2
10	65978	TAMPO APOIO/ SUPPORT TOP/ SOPORTE SUPERIOR	1200	585	12	1
MESA 1,70 / 1,70 TABLE/ MESA 1,70						
11	63212	TAMPO /TOP/ TAMPAA	1700	900	25	1
12	56368/ 63446	VIDRO OPCIONAL / OPTIONAL GLASS/ VIDRIO OPCIONAL	1700	900	4	1
MESA 1,60 / 1,60 TABLE/ MESA 1,60						
11	72714	TAMPO /TOP/ TAMPAA	1595	795	25	1
12	72593	VIDRO OPCIONAL / OPTIONAL GLASS/ VIDRIO OPCIONAL	1595	795	4	1

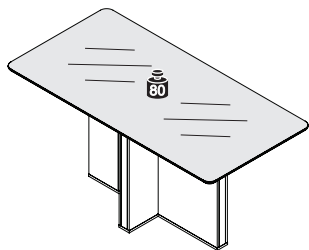

Rod. Prefeito Adolfo Nicolato, Km 10 - Rodeiro/MG - CEP:36510-000
+ 55 32 3577-3300 www.grupolopas.com.br

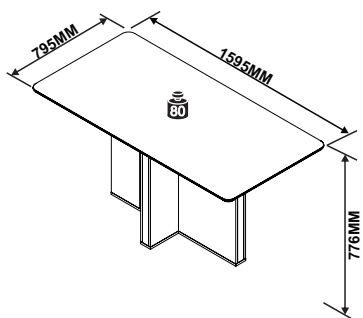

OPÇÃO COM VIDRO
OPTION WITH GLASS
OPCIÓN CON VIDRIO

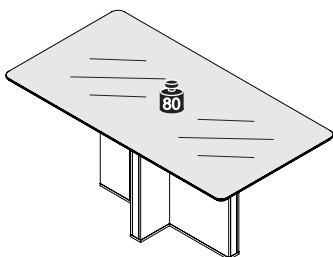
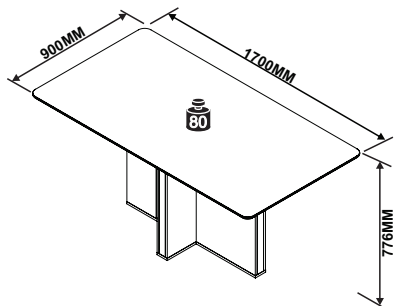

OPÇÃO COM VIDRO
OPTION WITH GLASS
OPCIÓN CON VIDRIO

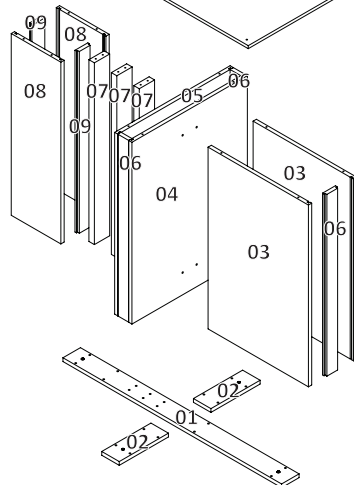
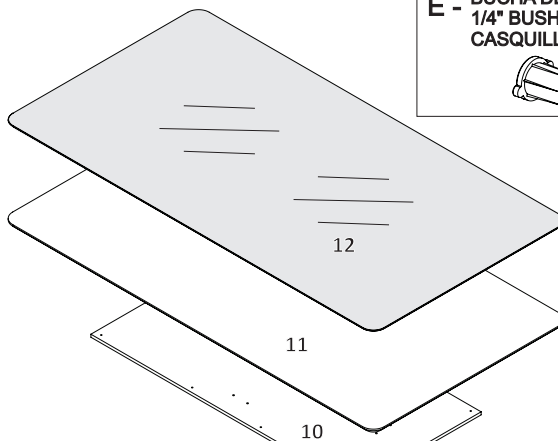

**A - PARAFUSO 5,0X40MM SOBERBO
5,0X40MM SCREW
TORNILLO 5,0X40MM** **44**
CÓD. 64863

**B - PARAFUSO 3,5X25MM FLANGEADO
3,5X25MM WASHER HEAD SCREW
TORNILLO 3,5X25MM FLANGEADO** **08**
CÓD. 64827

**C - SUPORTE DE SILICONE 13MM
13MM SILICONE SUPPORT
SOPORTE DE SILICONA 13MM** **08**
CÓD. 65084

**D - SAPATA REGULÁVEL
ADJUSTABLE SHOE
ZAPATO AJUSTABLE** **04**
CÓD. 65210

**E - BUCHA DE 1/4"
1/4" BUSHING
CASQUILLO 1/4"** **04**
CÓD. 66530

TERMO DE GARANTIA

DISPOSIÇÕES E PRAZOS DE GARANTIA

A Móveis Lopas estipula que o produto especificado terá garantia legal de 90 (noventa) dias, a partir da data de emissão da nota fiscal, contra defeitos de fabricação nos termos do artigo 26, II do CDC. Quaisquer garantias adicionais fornecidas pelo lojaista são de responsabilidade exclusiva destes, sendo, portanto os únicos responsáveis em caso de defeito do produto após a garantia legal, concedida pela fabricante.

A Móveis Lopas não possui pontos de assistência técnica. Constatado o eventual defeito de fabricação, desde que, dentro do prazo de garantia legal, o consumidor deverá entrar em contato com a loja onde adquiriu o produto.

No prazo de garantia, as partes eventualmente defeituosas serão substituídas gratuitamente, por outra da mesma linha e modelo.

O projeto, instalação e a montagem na residência do consumidor não serão de responsabilidade da Móveis Lopas.

A montagem deve seguir corretamente as instruções dos manuais que se encontram dentro da embalagem de cada módulo.

Esta garantia é válida em todo território brasileiro.

EXCLUSÃO DA GARANTIA

O presente termo exclui de sua garantia:
Danos causados em conseqüências de acidentes, mau uso, manuseio ou deslocamento incorreto dos produtos;
Avarias ou defeitos causados por montagem inadequada;
Danos em decorrência de agentes externos (inundações, incêndios, etc);
Danos causados pela utilização do produto em ambientes sujeitos a gases corrosivos, umidade excessiva, mofo, acondicionamento em locais de altas/baixas temperaturas, poeira ou acidez;
Danos causados por infestação de cupins e outras pragas;
Defeitos por exposição a luz solar excessiva;
Desgaste natural devido ao uso do produto;

CUIDE BEM DO SEU MÓVEL

Dicas de limpeza e conservação:
- Para limpar corretamente seu produto, use sempre um pano liso e levemente umedecido com água;
- Não se esqueça de enxugar o seu móvel! Ele não deve permanecer úmido, pois a água pode prejudicar o acabamento ou causar mofo na madeira;
- Não se recomenda o uso de produtos à base de amoníaco;
- Não utilize esponja de aço ou qualquer material que possa arranhá-lo durante a limpeza;
- Não utilize plásticos ou papéis coloridos para forrar seu móvel;
- Evite arrastar objetos em cima do móvel. Eles podem riscar e prejudicar o acabamento do seu móvel;
- O material dos seus móveis tem um tratamento contra fungos e cupins, mesmo assim, em ambientes infestados recomenda-se a desinfestação antes de instalar o seu móvel;
- Tente evitar a exposição direta ao sol. Sugere-se utilização de cortinas para proteger seu móvel;

A Móveis Lopas reserva-se o direito de alterar quaisquer características técnicas ou estéticas e introduzir melhoramentos nos produtos comercializados a qualquer momento, sem obrigação de efetuar o mesmo nos produtos em estoque ou já comercializados (vendidos).

TAKING GOOD CARE OF YOUR FURNITURE

Cleaning and caring instructions:

- Wipe the wood furniture down with a moist cloth to properly clean the furniture.
- Do not forget to dry your furniture out. Humidity can damage the finish or create mould.
- Chemical products are not recommended;
- Never clean the furniture with scouring powders, steel scrubber pads or any other product which can scratch it.
- Furniture surfaces should not be covered with colored plastic or paper sheets.
- Avoid dragging objects on top of the furniture. They might scratch the finishing.
- Wood furniture are made of mould and termites resistant materials, however, it is recommended to use termiticides in infested places before installing the furniture.
- Avoid furniture exposure to direct Sun light. Drapers suggested.

CUIDE BIEN DE SU MUEBLE

Indicaciones de limpieza y conservación

- Para limpiar correctamente su muebles de madera, siempre use un paño húmedo.
- No se olvide de secar su muebles! No debe permanecer húmedo, pues el agua puede perjudicar el acabado o causar moho en la madera.
- No es recomendable utilizar productos con amoníaco.
- No utilizar esponjas de acero o cualquier material que dañe la superficie de los muebles.
- No utilizar plásticos o papeles coloridos para forrar los muebles.
- Evite arrastrar objetos encima de los muebles. Ellos pueden riscar o dañar el acabado de su mueble.
- El material de los muebles tiene un tratamiento contra los hongos y las polillas, aun así, en ambientes infestados, se recomienda desinfectar antes de instalar su mueble.
- Evite la exposición directa al sol. Se sugiere la utilización de cortinas para proteger sus muebles.

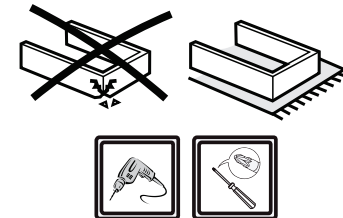

As ferramentas necessárias para montagem do produto não são fornecidas.
The necessary tools for assembly aren't supplied.
Las herramientas necesarias para armar los productos no son fornecidas.



Sugestão da quantidade de pessoas necessárias para montagem.
Tip of the number of people required for product assembly.
Consejo de la cantidad de personas necesarias para el armado de productos.

Instruções de Montagem Mesa 1,60/1,70M Astrid Assembly Instructions Astrid Table 1.60/1.70M Instrucciones de Armado Mesa Astrid 1,60/1,70M

65880 - A4 - 25/04/2023

KG Peso máximo suportado
Maximum weight supported
Peso máximo suportado

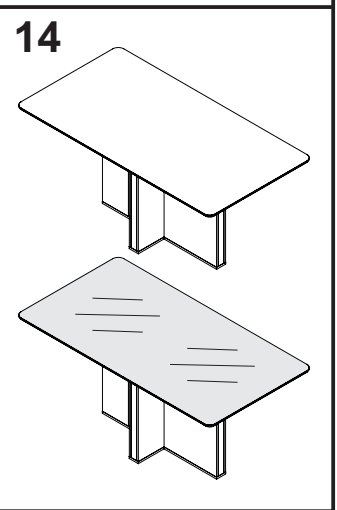
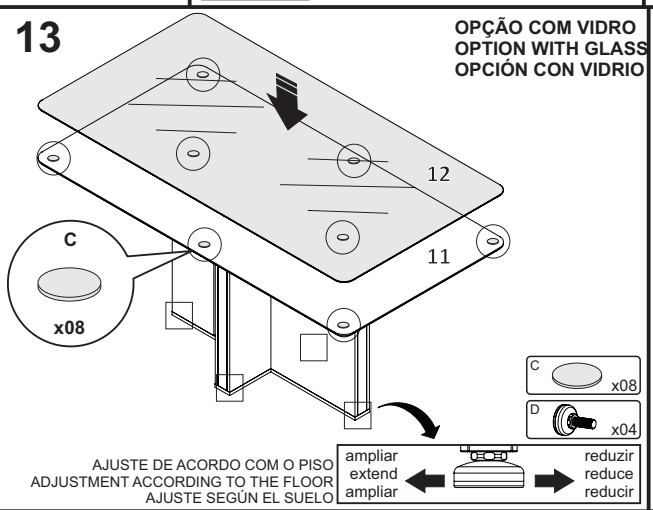
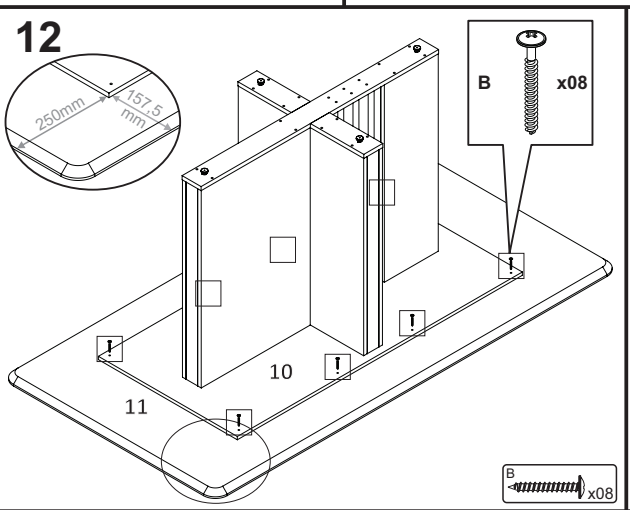
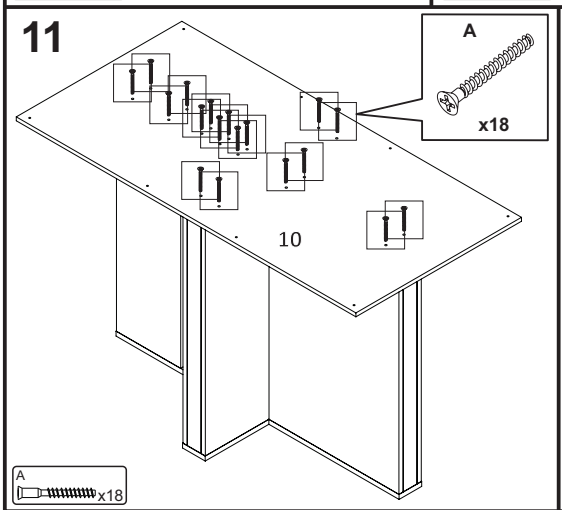
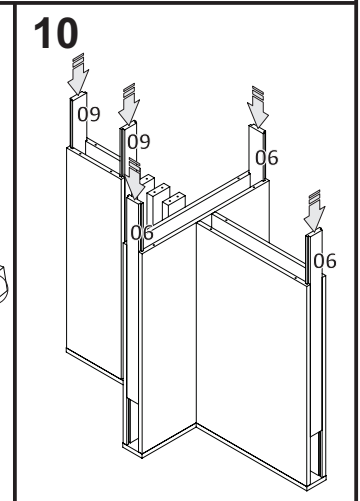
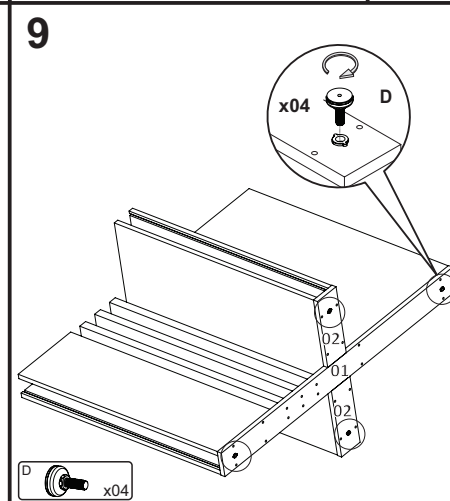
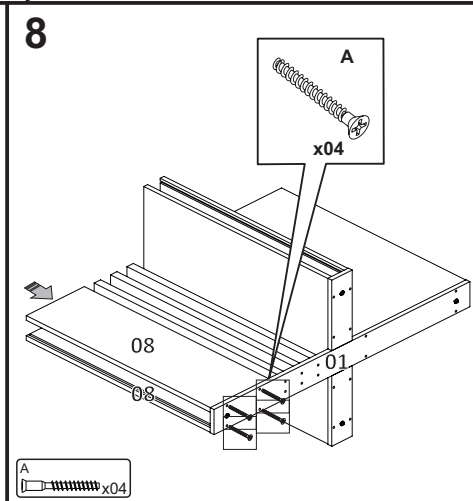
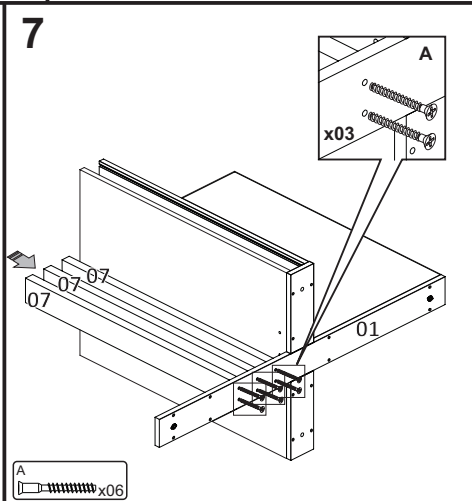
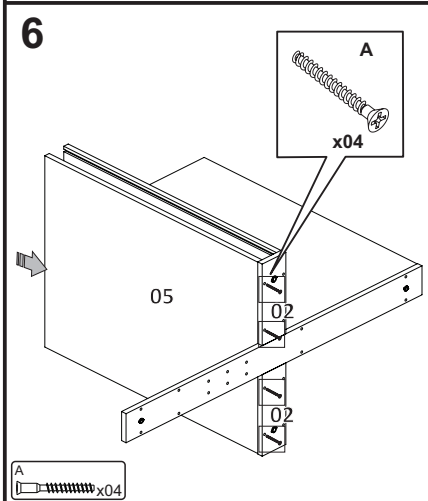
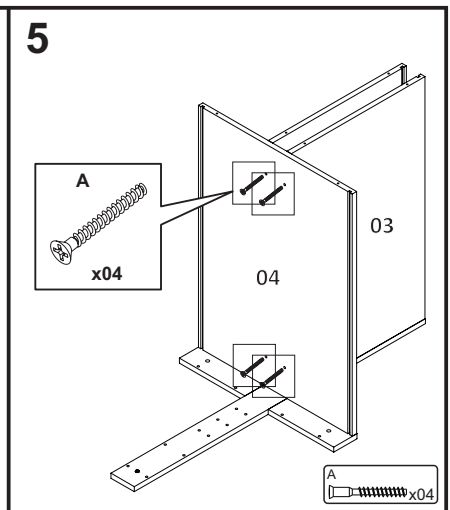
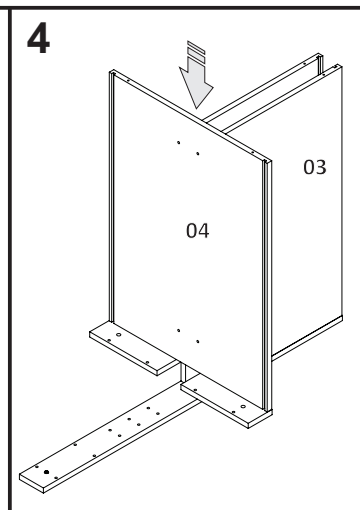
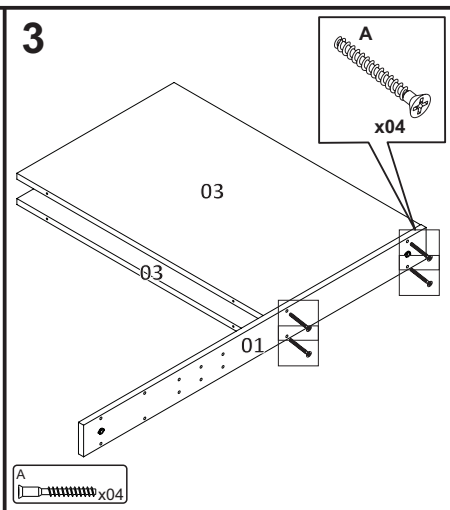
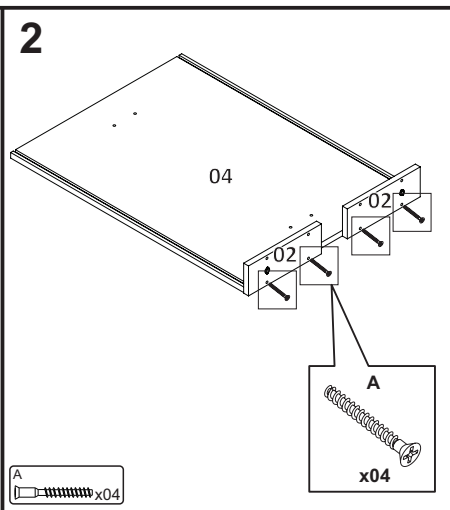
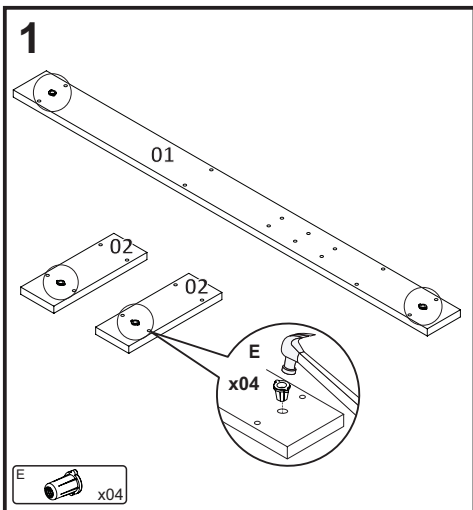

N°	CÓDIGO CODE CÓDIGO	DESCRIÇÃO DESCRIPTION DESCRIPCIÓN	DIMENSÃO (mm) DIMENSION (mm) DIMENSIÓN (mm)			QUANTIDADE QUANTITY CANTIDAD
			COMP. LEN. LON.	LARG. WID. ANC.	EPS DEP ESP	
1	58717	PÉ FRONTAL/ FRONT FOOT/ PIE FRONTAL	450	60	25	4
2	74528	PÉ TRASEIRO/ BACK FOOT/ PIE TRASEIRO	450	132	25	4
3	74791	TRAVESSA FRONTAL/ FRONT BATTEN/ TRAVIESSA FRONTAL	360	70	15	4
4	74793	TRAVESSA LATERAL/ SIDE BATTEN/ TRAVIESSA LATERAL	350	70	15	4
5	66405	APLIQUE/ DETAIL/ DETALLE	430	30	25	2
6	54268	ASSENTO/ SEAT/ ASIENTO	495	465	130	2
7	66420	ENCOSTO/ BACKBOARD/ RESPALDO PRIVILEGE	640	470	180	2



Rod. Prefeito Adolfo Nicolato, Km 10 - Rodeiro/MG - CEP:36510-000
+ 55 32 3577-3300 www.grupolopas.com.br

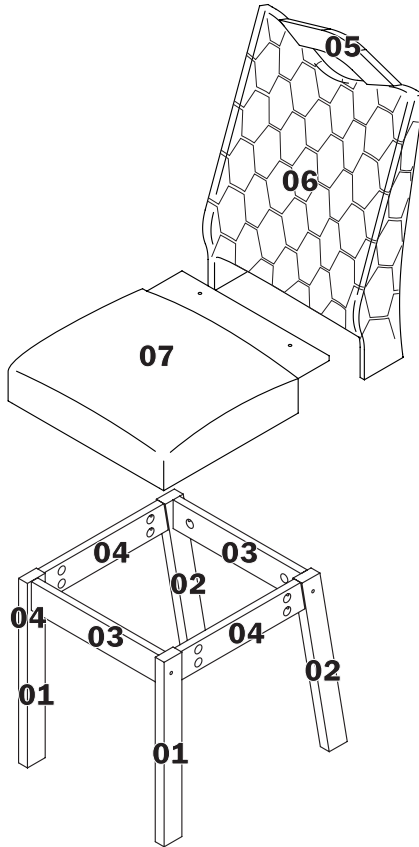
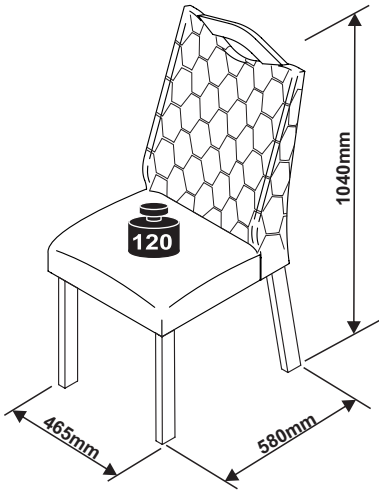

Instruções de Montagem Cadeira Vênus

Assembly Instructions Vênus Chair

Instrucciones de Armado Silla Vênus

74776 - A4 - 15/02/2023

KG Peso máximo suportado
Maximum weight supported
Peso máximo soportado

K - ARRUELA 1/4"
1/4" WASHER
ARANDELA 1/4"

24
CÓD. 65087

L - CAVILHA PLÁSTICA 8X40MM
8X40MM PLASTIC DOWEL
TARUGO DE PLASTICO 8X40MM

04
CÓD. 74221

A - ANEL DE FIXAÇÃO
FIXATION RING
ANILLO DE FIJACIÓN

24
18MM
CÓD. 64973

B - CANTONEIRA DOIS FUROS
TWO-HOLED CORNER PLATE
ESQUINERO DOS ORIFÍCIOS

08
CÓD. 65630

C - CHAPA UNIÃO C/08 FUROS
UNION BLADE WITH 08 HOLES
PLACA DE UNIÃO CON 08 ORIFÍCIOS

04
33,5X80MM
CÓD. 65614

D - CHAVE ZETA
ALLEN WRENCH
LLAVE CETA

01
460X28X4MM
CÓD. 64981

E - PARAFUSO 1/4X100MM
1/4X100MM SCREW
TORNILLO 1/4X100MM

16
CÓD. 64840

F - PARAFUSO 1/4X80MM
1/4X80MM SCREW
TORNILLO 1/4X80MM

08
CÓD. 64849

G - PARAFUSO 3,5X14MM
3,5X14MM SCREW
TORNILLO 3,5X14MM

32
CÓD. 64725

H - PARAFUSO 7X50MM
7X50MM SCREW
TORNILLO 7X50MM

04
CÓD. 64859

I - PARAFUSO 3,5X12MM FLANGEADO
3,5X12MM WASHER HEAD SCREW
TORNILLO 3,5X12MM FLANGEADO

16
CÓD. 64825

J - SAPATA REDONDA
CIRCULAR PAD
ZAPATA CIRCULAR

08
CÓD. 67081

TERMO DE GARANTIA

DISPOSIÇÕES E PRAZOS DE GARANTIA

A Móveis LOPAS estipula que o produto especificado terá garantia legal de 90 (noventa) dias, a partir da data de emissão da nota fiscal, contra defeitos de fabricação nos termos do artigo 26, II do CDC. Quaisquer garantias adicionais fornecidas pelo lojista são de responsabilidade exclusiva deste, sendo, portanto os únicos responsáveis em caso de defeito do produto após a garantia legal, concedida pela fabricante.

A Móveis LOPAS não possui pontos de assistência técnica. Constatado o eventual defeito de fabricação, desde que, dentro do prazo de garantia legal, o consumidor deverá entrar em contato com a loja onde adquiriu o produto. No prazo de garantia, as partes eventualmente defeituosas serão substituídas gratuitamente, por outra da mesma linha e modelo. O projeto, instalação e a montagem na residência do consumidor não serão de responsabilidade da Móveis LOPAS. A montagem deve seguir corretamente as instruções dos manuais que se encontram dentro da embalagem de cada módulo. Esta garantia é válida em todo território brasileiro.

EXCLUSÃO DA GARANTIA

O presente termo exclui de sua garantia: Danos causados em conseqüências de acidentes, mau uso, manuseio ou deslocamento incorreto dos produtos; Danos ou defeitos causados por montagem inadequada; Danos em decorrência de agentes externos (inundações, incêndios, etc); Danos causados pela utilização do produto em ambientes sujeitos a gases corrosivos, umidade excessiva, mofo, acondicionamento em locais de altas/baixas temperaturas, poeira ou acidez; Danos causados por infestação de cupins e outras pragas; Defeitos por exposição a luz solar excessiva; Desgaste natural devido ao uso do produto;

CUIDE BEM DO SEU MÓVEL

Dicas de limpeza e conservação:
- Para limpar corretamente seu produto, use sempre um pano liso e levemente umedecido com água;
- Não se esqueça de enxugar o seu móvel! Ele não deve permanecer úmido, pois a água pode prejudicar o acabamento ou causar mofo na madeira;
- Não se recomenda o uso de produtos à base de amoníaco;
- Não utilize esponja de aço ou qualquer material que possa arranhar a superfície do produto durante a limpeza;
- Não utilize plásticos ou papéis coloridos para forrar seu móvel;
- Evite arrastar objetos em cima do móvel. Eles podem riscar e prejudicar o acabamento do seu móvel;
- O material dos seus móveis tem um tratamento contra fungos e cupins, mesmo assim, em ambientes infestados recomenda-se a desidratação antes de instalar o seu móvel;
- Tente evitar a exposição direta ao sol. Sugere-se utilização de cortinas para proteger seu móvel;

A Móveis LOPAS reserva-se o direito de alterar quaisquer características técnicas ou estéticas e introduzir melhoramentos nos produtos comercializados a qualquer momento, sem obrigação de efetuar o mesmo nos produtos em estoque ou já comercializados (vendidos).

TAKING GOOD CARE OF YOUR FURNITURE

Cleaning and caring instructions:

- Wipe the wood furniture down with a moist cloth to properly clean the furniture.
- Do not forget to dry your furniture out. Humidity can damage the finish or create mold.
- Chemical products are not recommended;
- Never clean the furniture with scouring powders, steel scrubber pads or any other product which can scratch its surface.
- Furniture surfaces should not be covered with colored plastic or paper sheets.
- Avoid dragging objects on top of the furniture. They might scratch the finishing.
- Wood furniture are made of mould and termites resistant materials, however, it is recommended to use termiticides in infested places before installing the furniture.
- Avoid furniture exposure to direct Sun light. Drapers suggested.

CUIDE BIEN DE SU MUEBLE

Indicaciones de limpieza y conservación

- Para limpiar correctamente su muebles de madera, siempre use un paño húmedo.
- No se olvide de secar su muebles! No debe permanecer húmedo, pues el agua puede perjudicar el acabado o causar moho en la madera.
- No es recomendable utilizar productos con amoníaco.
- No utilizar esponjas de acero o cualquier material que dañe la superficie de los muebles.
- No utilizar plásticos o papeles coloridos para forrar los muebles.
- Evite arrastrar objetos encima de los muebles. Ellos pueden riscar o dañar el acabado de su mueble.
- El material de los muebles tiene un tratamiento contra los hongos y las polillas, aun así, en ambientes infestados, se recomienda desinfectar antes de instalar su mueble.
- Evite la exposición directa al sol. Se sugiere la utilización de cortinas para proteger sus muebles.

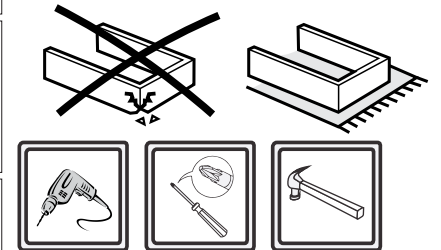

As ferramentas necessárias para montagem do produto não são fornecidas. The necessary tools for assembly aren't supplied. Las herramientas necesarias para armar los productos no son fornecidas.

Montagem
Mounting
Montaje

Sugestão da quantidade de pessoas necessárias para montagem.
Tip of the number of people required for product assembly.
Consejo de la cantidad de personas necesarias para el armado de productos.

Tempo de montagem
Assembly time
Tempo de armado

30min.

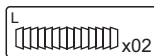
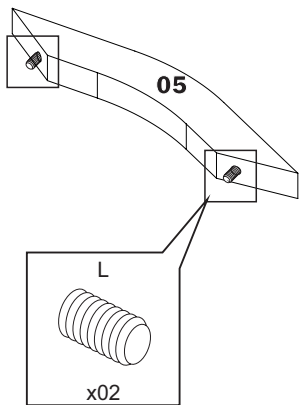
01**02**

ENCAIXAR O ANEL DE FIXAÇÃO COM A PORCA VIRADA PARA O PARAFUSO.
PUT THE FIXATION RING SCREWING THE NUT.
ENCAJAR EL ANILLO DE FIJACIÓN ATORNILLANDO LA TUERCA.

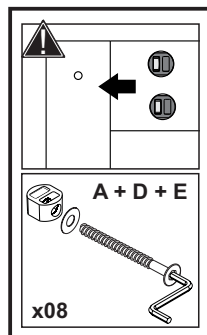

A + D + E

x08

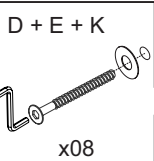
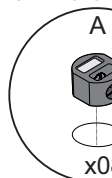

D + E + K

x08



E

x04



A



D



01



K



01



01



01



01



01



K



01



01



01



01



01



01



01



01



01



01



01

03

ENCAIXAR O ANEL DE FIXAÇÃO COM A PORCA VIRADA PARA O PARAFUSO.
PUT THE FIXATION RING SCREWING THE NUT.
ENCAJAR EL ANILLO DE FIJACIÓN ATORNILLANDO LA TUERCA.

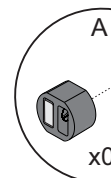

A

x02

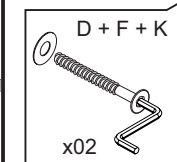

D + F + K

x02



D



F



02



02



02



02

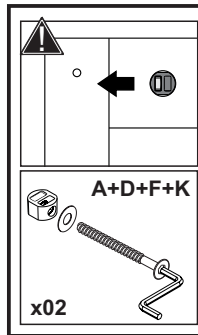

A + D + F + K

x02



K



02



02

04

ENCAIXAR O ANEL DE FIXAÇÃO COM A PORCA VIRADA PARA O PARAFUSO.
PUT THE FIXATION RING SCREWING THE NUT.
ENCAJAR EL ANILLO DE FIJACIÓN ATORNILLANDO LA TUERCA.

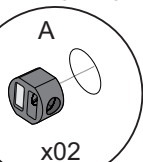
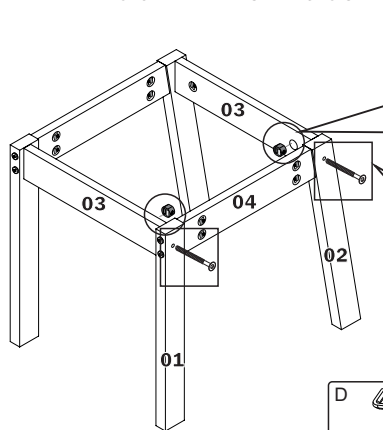

A

x02

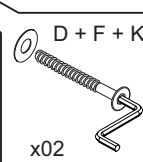

D + F + K

x02

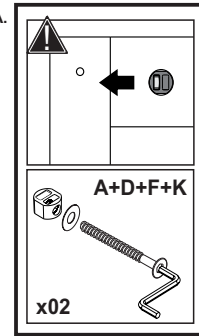

A + D + F + K

x02



K



02



02



D



F



02



02



02



02



02



02



02



02



02



02



02



02



02



02



02



02



02



02



02



02



02

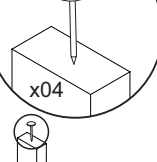
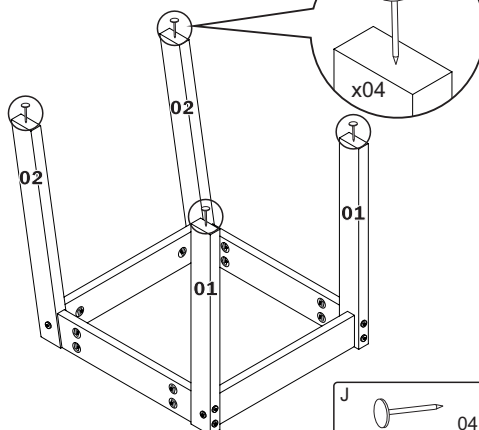

02

05

J

x04

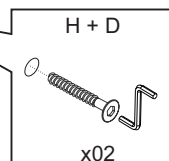
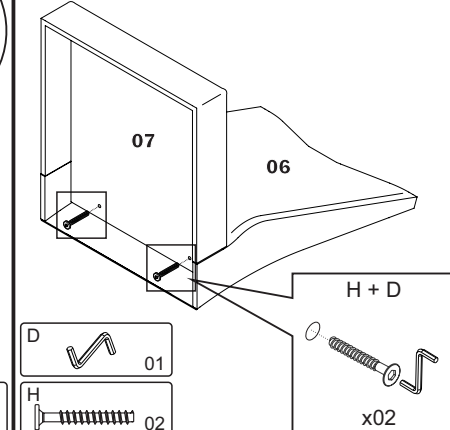

04

06

H + D

x02



D



01



H



02



02



02



02



02



02



02



02



02

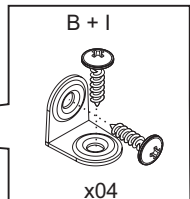
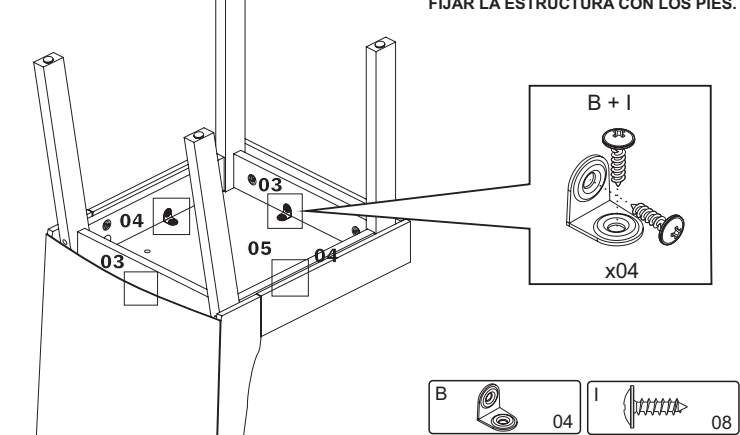

02

08

B + I

x04



B



04



I

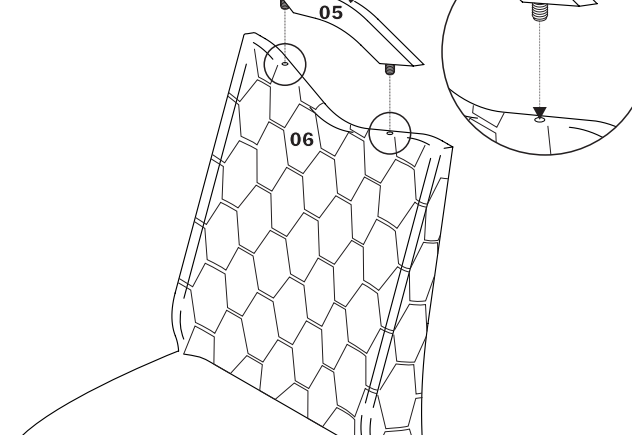

08

09**10**