

BALCÃO 120CM 1 PORTA 2 GAV / COUNTER 120CM 1 DOOR 2 DRAWERS / MOSTRADOR 120CM 1 PUERTA 2 CAJONES
PH-3074

Montagem

Recomenda-se a leitura prévia das instruções de montagem e profissionais especializados para montar.

Assistência

Caso ocorra problema com algum dos componentes, sublinhe-o, identifique o problema e retorne esta relação, via fax ou outro meio de comunicação disponível para o representante.

Assinatura do cliente

Assembly

Before the assembling is recommended to read carefully the assembly instruction by professional assemblers.

Assistance

If happen problems with any component, underline the same, identify the problem and send back this relation immediately, by fax or other way.

Client signature

Montaje

Se recomienda la lectura previa de las instrucciones de montaje y profesionales especializados para montarlos.

Assistencia

Caso sucedan problemas con alguno de los componentes, subraye el componente, identifique el problema, y retorne esta copia via fax u otro medio de comunicación posible.

Assinatura del cliente

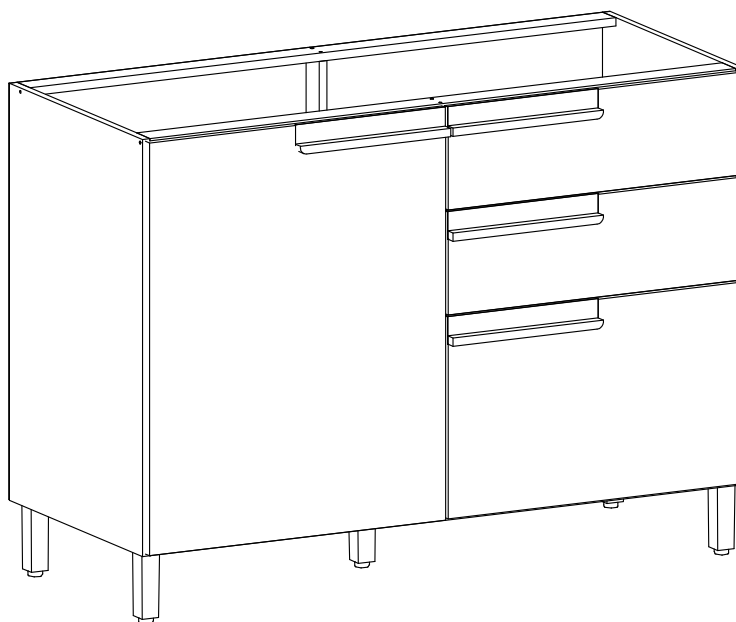

Atenção / Attention / Atención

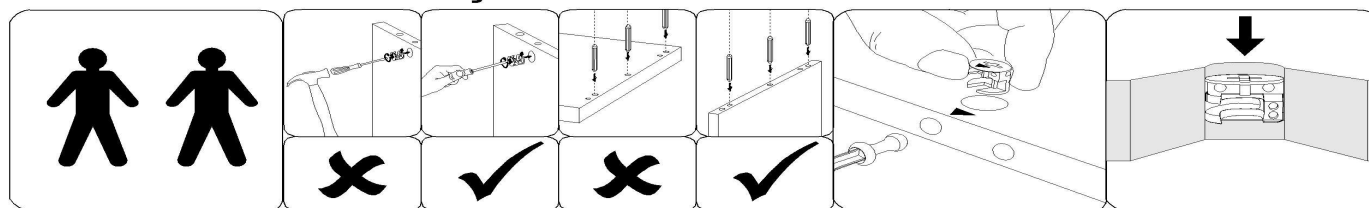

A Heval se reserva o direito de efetuar alterações nos produtos de suas linhas sem aviso prévio, quando entender necessário.

Herval reserves the right to effect modifications in the products, without previous advice, when understand necessary.

Herval se reserva el derecho de hacer las modificaciones que juzgue necesarias en sus productos, sin aviso previo, cuando lo crea necesario.

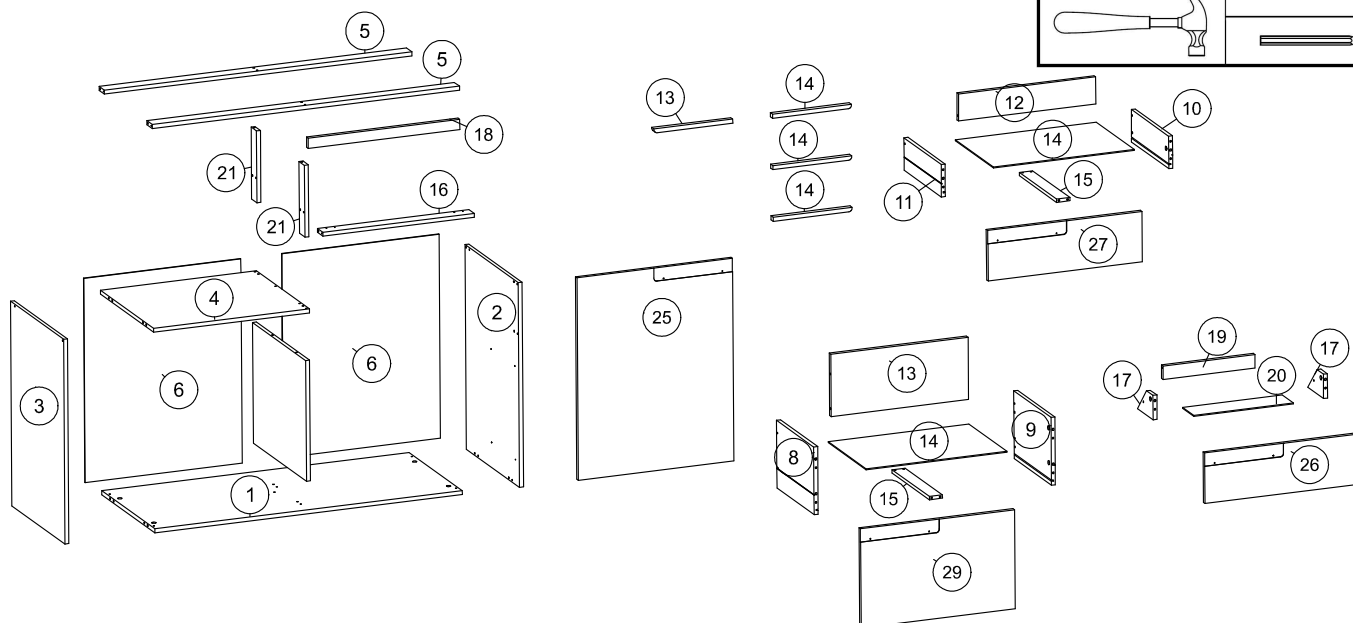

LISTA DE PEÇAS / PARTS LIST / LISTA DE PIEZAS

Volume 1 / Carton 1 / Caja 1

ÍNDICE / INDEX	CÓD. / CODE	PEÇA / PART / PIEZA	MED/MEASURE	QTDE / QUANT / CANT
1	159784E	BASE	1170.0x500.0x15.0	1
2	159794E	LATERAL DIREITA	755.0x500.0x15.0	1
3	159795E	LATERAL ESQUERDA	755.0x500.0x15.0	1
4	159796E	PRATELEIRA	593.0x500.0x15.0	1
5	159788E	TRAVESSA TAMPO	1170.0x50.0x15.0	2
6	159789E	FUNDO	753.0x598.0x3.0	2
7	159797E	DIVISÃO	445.0x500.0x15.0	1
8	159779E	LATERAL DE GAV ESQ. MAIOR	350.0x250.0x15.0	1
9	159778E	LATERAL DE GAV DIR. MAIOR	350.0x250.0x15.0	1
10	159777E	LATERAL DE GAV. DIR.	350.0x120.0x15.0	1
11	159776E	LATERAL DE GAV. ESQ.	350.0x120.0x15.0	1
12	159800E	TRASEIRO DE GAVETA	522.0x100.0x15.0	1
13	159801E	TRASEIRO DE GAVETA MAIOR	522.0x230.0x15.0	1
14	159802E	FUNDO DE GAVETA	357.0x536.0x3.0	2
14	1609851	PUXADOR DIREITO MANHATTAN	300.3x15.0x20.0	3
15	159783E	SUPORTE GAVETA	350.0x50.0x12.0	2
16	159803E	TRAVESSA	577.0x50.0x15.0	1
17	159804E	LATERAL PORTA TEMP.	147.0x90.0x15.0	2
18	159805E	VISTA	577.0x38.0x15.0	1
19	159806E	TRASEIRO PORTA TEMP.	350.0x50.0x15.0	1
20	159807E	FUNDO PORTA TEMP.	379.0x105.0x3.0	1
21	159808E	TRAVESSA VERTICAL	265.0x50.0x15.0	2
23	1609550	PÉ C/ SAPATA REGULÁVEL PLÁSTICA 0203420	xx	5
24	1609590	CORRED TRIL TELESC LIGHT 300MM	xx	4
28	1609852	PUXADOR ESQUERDO MANHATTAN	300.3x15.0x20.0	1
30	K072721	KIT 4 DOB 35MM ALTA - CALÇO FIXO - COM AMORT	xx	1
31	K072725	KIT PH3074 MÓD. BALCÃO 120CM 1 PORTA 2 GAV	xx	1
G	-	TAPA FURO ADESIVO PAPEL 15mm	15.0x15.0x0.5	5
N	XXXXXXX	TAPA FURO ADESIVO PAPEL 20MM	22.0x22.0x0.5	12

Volume 2 / Carton 2 / Caja 2

ÍNDICE / INDEX	CÓD. / CODE	PEÇA / PART / PIEZA	MED/MEASURE	QTDE / QUANT / CANT
25	159790E	PORTA ESQUERDA	747.0x592.0x15.0	1
26	159809E	FRENTE PORTA TEMP.	587.0x186.0x15.0	1
27	159810E	FRENTE GAVETA	587.0x186.0x15.0	1
29	159811E	FRENTE DE GAV. MAIOR	587.0x365.0x15.0	1

LISTA DE ACESSÓRIOS / FITTINGS LIST / LISTA DE ACESSORIOS

					CÓD./ CODE: K072725	
REF.	PEÇA	PART	PIEZA	QTDE	CÓDIGO	
A	PARAFUSO MINIFIX	Cam Bolt 32xØ6mm	Perno de Leva 32xØ6mm	14	1602006	
B	TAMBOR MINIFIX Ø14.9X11MM	Can Nut Ø15 mm	Porca de Leva Ø15 mm	14	1605358	
C	PREGO 10 X 10 C/CABEÇA - Ø1,5 x 23mm	Nail 10 X 10 - Ø1,5 x 23mm	Clavo 10 X 10	55	1605365	
D	FIXADOR PARA COSTAS ZINCO BR	Back Panel Bracket	Soporte Panel Trasero	5	1601469	
E	CANTONEIRA 20x20x42mm (08.02.096)	BRACKET 20X20X42MM	PARÉNTESIS 20X20X42MM	3	-	
F	CAVILHA DE MADEIRA 6X40	Dowel Ø6 x 40 mm	Tarugo Ø6 x 40 mm	40	1604742	
H	PARAFUSO 4 X 40 CAB. CHATA PHILIPS	Screw Ø4 x 40 mm	Tornilo Ø4 x 40 mm	22	1604937	
I	PARAFUSO 4 X 14 CAB. CHATA REBAIXADA PHILIPS	Screw Ø4 x 14 mm	Tornilo Ø4 x 14 mm	28	1602420	
J	PARAFUSO 4.5 X 35 CAB. CHATA PHILIPS	Screw Ø4.5 x 35 mm	Tornilo Ø4.5 x 35 mm	5	4,5x35	
K	PARAFUSO 4 X 25 CAB. CHATA PHILIPS	Screw Ø4 x 25 mm	Tornilo Ø4 x 25 mm	12	1607862	
L	PARAFUSO 3 X 30 CAB. CHATA PHILIPS	Screw Ø3 x 30 mm	Tornilo Ø3 x 30 mm	4	1607848	

KIT DOBRADIÇAS / HINGES KIT / KIT BISAGRAS

					CÓD./ CODE: K072721	
REF.	PEÇA	PART	PIEZA	QTDE	CÓDIGO	
I	PARAFUSO 4 X 14 CAB. CHATA REBAIXADA PHILIPS	Screw Ø4 x 14 mm	Tornilo Ø4 x 14 mm	24	1602420	
M	DOB. ALTA AMORT 35MM (4115402991)	HIGH HATCHE 35MM	HATCHE ALTO 35MM	4	1768796	

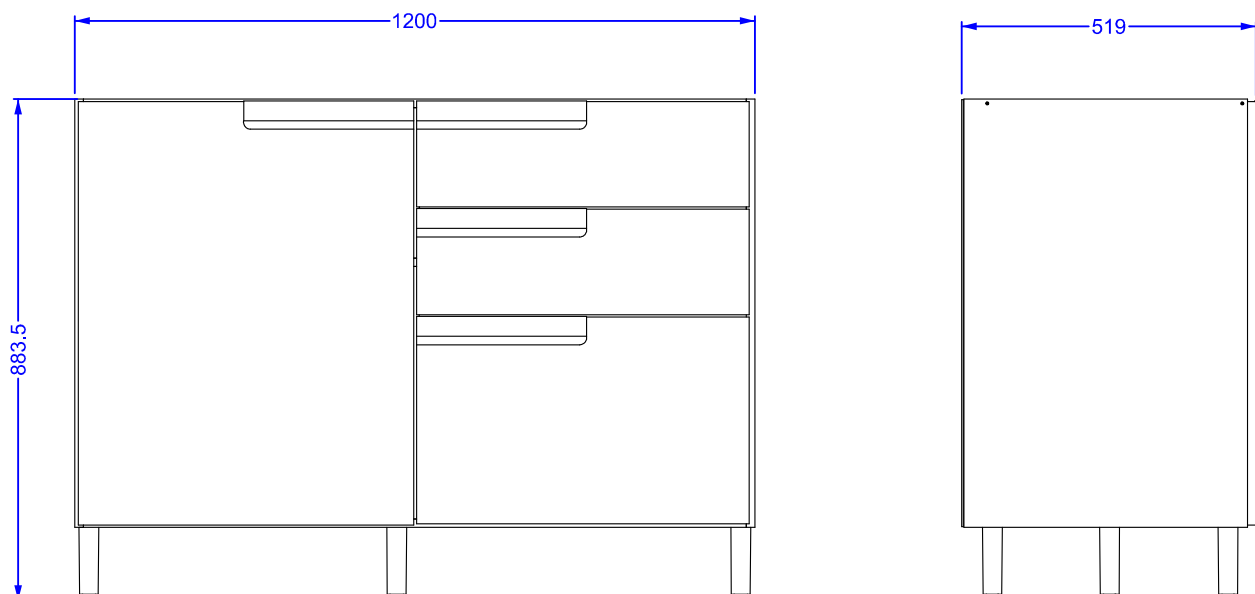



**PASSO 1
STEP 1
PASO 1**

PEÇAS NECESSÁRIAS
PARTS REQUIRED
PIEZAS NECESARIAS

INDICE	QUANT.
5	2
7	1
18	1
21	2

FERRAGEM NECESSÁRIA
HARDWARE REQUIRED
HERRAMIENTA NECESARIA

INDICE	IMAGEM	QTDE
E		3
F		12
I		6

FERRAMENTAS NECESSÁRIAS
TOOL REQUIRED
HERRAMIENTA NECESARIA

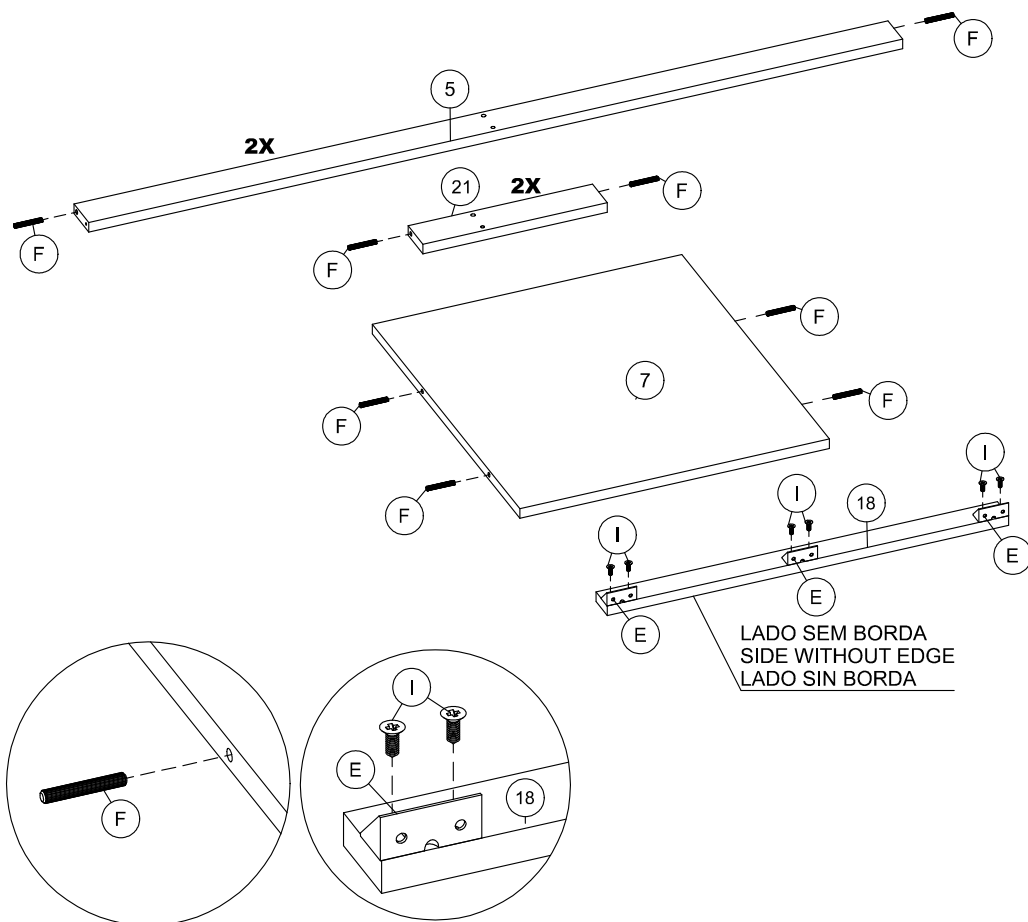
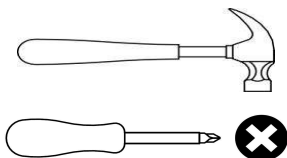



**PASSO 2
STEP 2
PASO 2**

PEÇAS NECESSÁRIAS
PARTS REQUIRED
PIEZAS NECESARIAS

INDICE	QUANT.
1	1
4	1
5	1
18	1

FERRAGEM NECESSÁRIA
HARDWARE REQUIRED
HERRAMIENTA NECESARIA

INDICE	IMAGEM	QTDE
F		6
I		12

FERRAMENTAS NECESSÁRIAS
TOOL REQUIRED
HERRAMIENTA NECESARIA

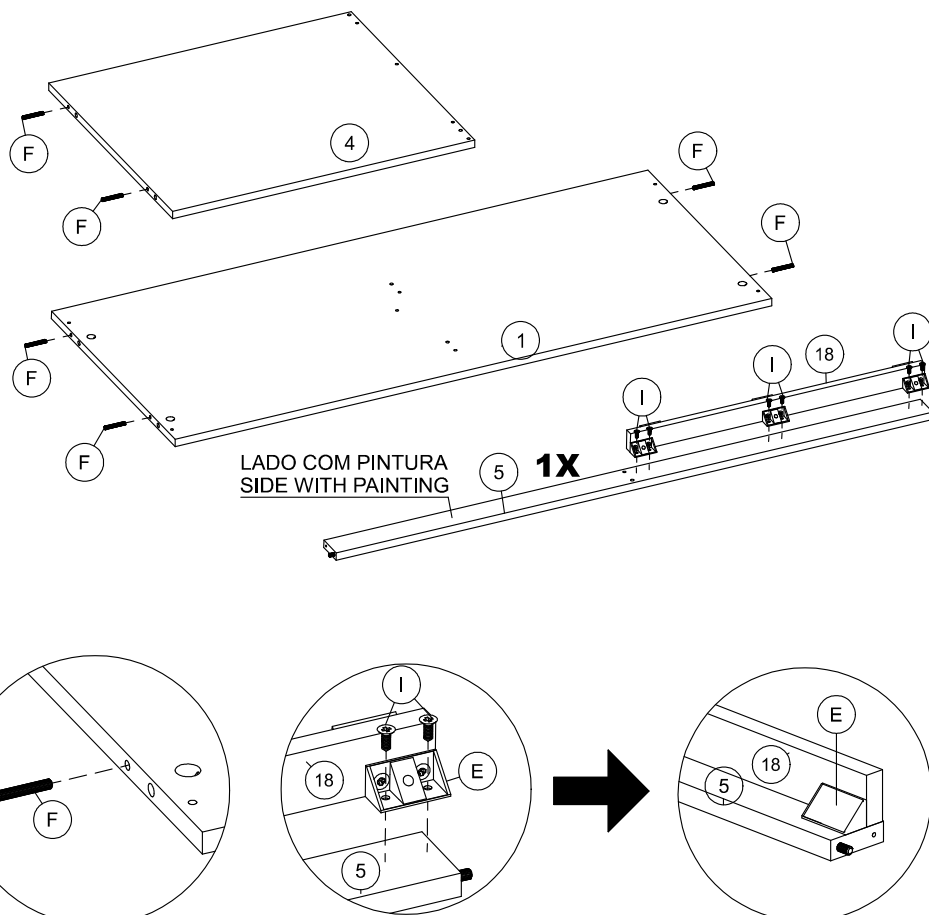
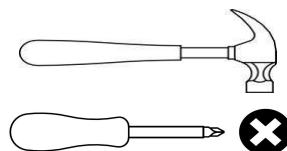

**PASSO 3
STEP 3
PASO 3**

PEÇAS NECESSÁRIAS
PARTS REQUIRED
PIEZAS NECESARIAS

INDICE	QUANT.
2	1
3	1

FERRAGEM NECESSÁRIA
HARDWARE REQUIRED
HERRAMIENTA NECESARIA

INDICE	IMAGEM	QTDE
A		6

FERRAMENTAS NECESSÁRIAS
TOOL REQUIRED
HERRAMIENTA NECESARIA

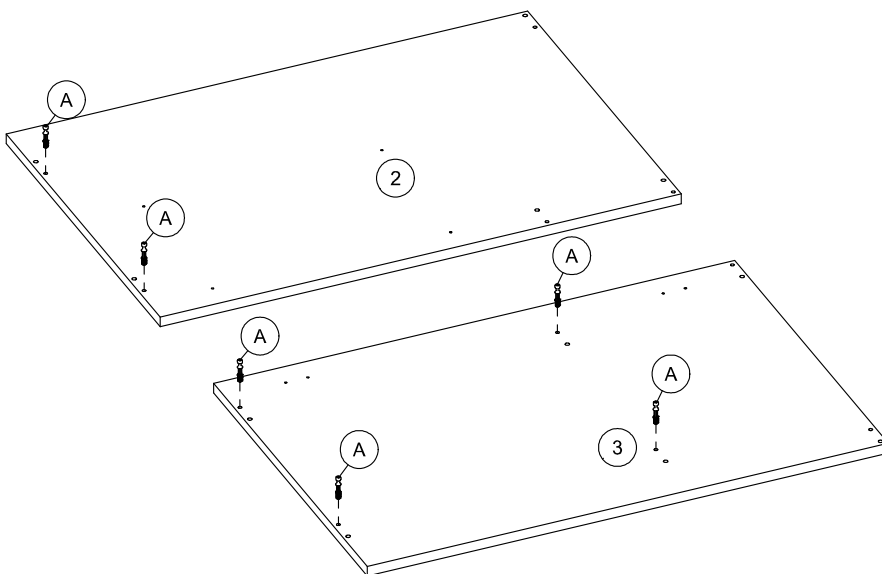
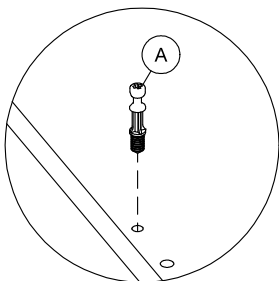
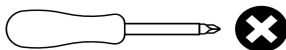

**PASSO 4
STEP 4
PASO 4**

PEÇAS NECESSÁRIAS
PARTS REQUIRED
PIEZAS NECESARIAS

INDICE	QUANT.
2	1
7	1
24	2

FERRAGEM NECESSÁRIA
HARDWARE REQUIRED
HERRAMIENTA NECESARIA

INDICE	IMAGEM	QTDE
I		8

FERRAMENTAS NECESSÁRIAS
TOOL REQUIRED
HERRAMIENTA NECESARIA

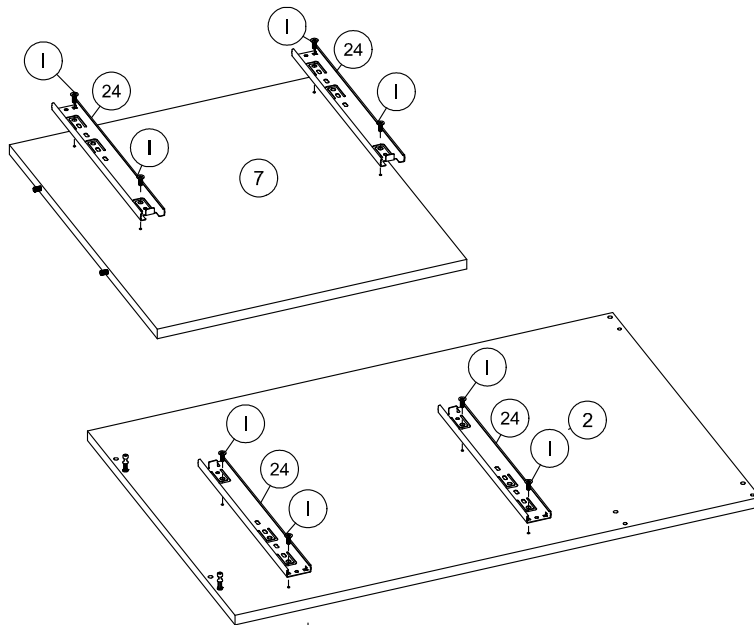
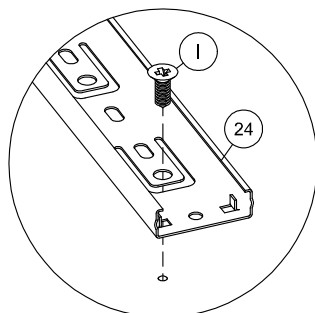

**PASSO 5
STEP 5
PASO 5**

PEÇAS NECESSÁRIAS
PARTS REQUIRED
PIEZAS NECESARIAS

INDICE	QUANT.
1	1
23	1

FERRAGEM NECESSÁRIA
HARDWARE REQUIRED
HERRAMIENTA NECESARIA

INDICE	IMAGEM	QTDE
J		1

FERRAMENTAS NECESSÁRIAS
TOOL REQUIRED
HERRAMIENTA NECESARIA

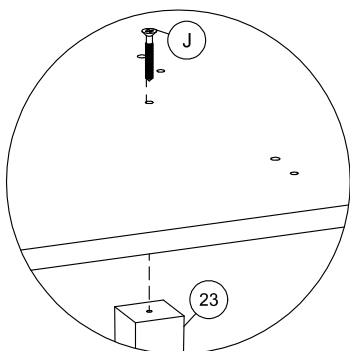
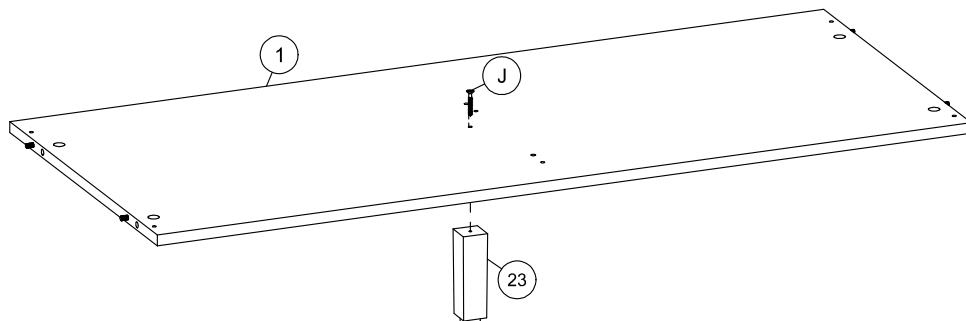
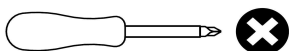

**PASSO 6
STEP 6
PASO 6**

PEÇAS NECESSÁRIAS
PARTS REQUIRED
PIEZAS NECESARIAS

INDICE	QUANT.
4	1
21	2

FERRAGEM NECESSÁRIA
HARDWARE REQUIRED
HERRAMIENTA NECESARIA

INDICE	IMAGEM	QTDE
H		2

FERRAMENTAS NECESSÁRIAS
TOOL REQUIRED
HERRAMIENTA NECESARIA

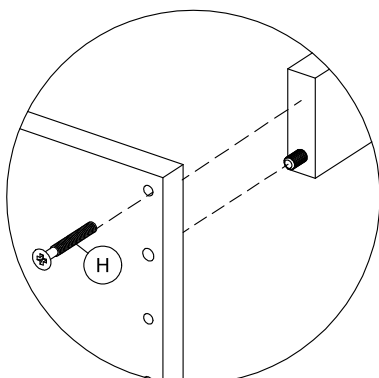
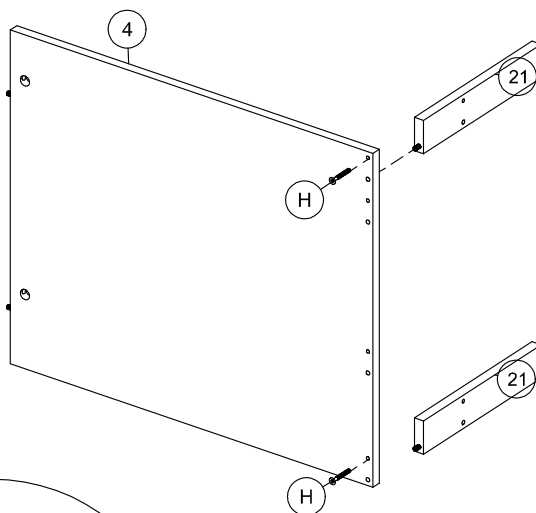
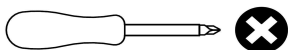

**PASSO 7
STEP 7
PASO 7**

PEÇAS NECESSÁRIAS
PARTS REQUIRED
PIEZAS NECESARIAS

INDICE	QUANT.
4	1
7	1
21	2

FERRAGEM NECESSÁRIA
HARDWARE REQUIRED
HERRAMIENTA NECESARIA

INDICE	IMAGEM	QTDE
H		4

FERRAMENTAS NECESSÁRIAS
TOOL REQUIRED
HERRAMIENTA NECESARIA

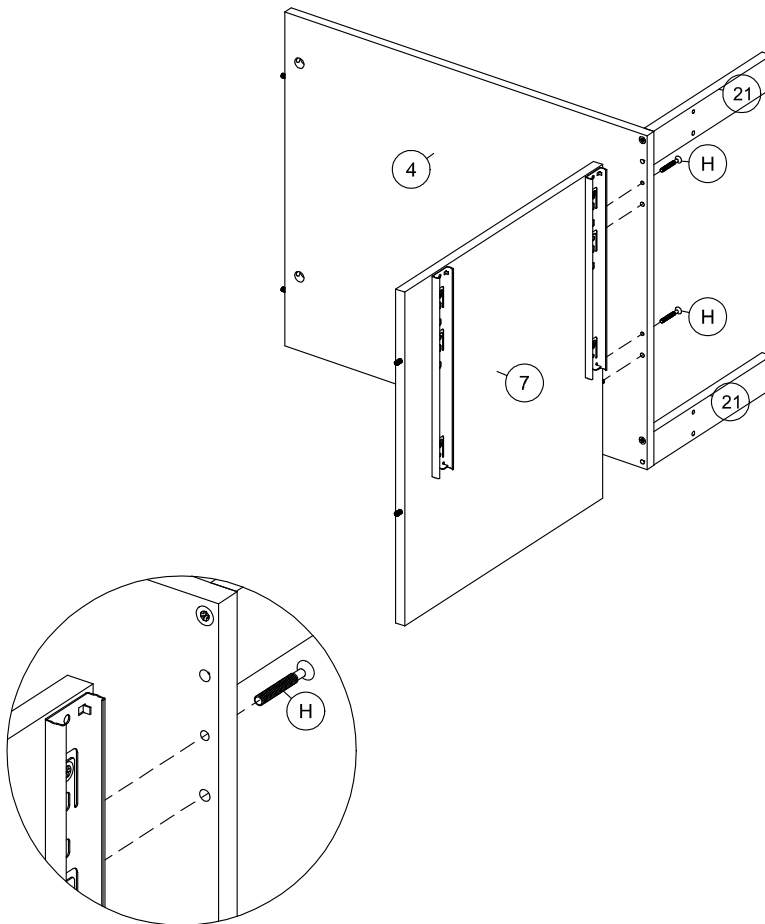
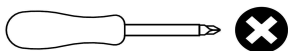

**PASSO 8
STEP 8
PASO 8**

PEÇAS NECESSÁRIAS
PARTS REQUIRED
PIEZAS NECESARIAS

INDICE	QUANT.
1	1
4	1
7	1
21	2

FERRAGEM NECESSÁRIA
HARDWARE REQUIRED
HERRAMIENTA NECESARIA

INDICE	IMAGEM	QTDE
H		2

FERRAMENTAS NECESSÁRIAS
TOOL REQUIRED
HERRAMIENTA NECESARIA

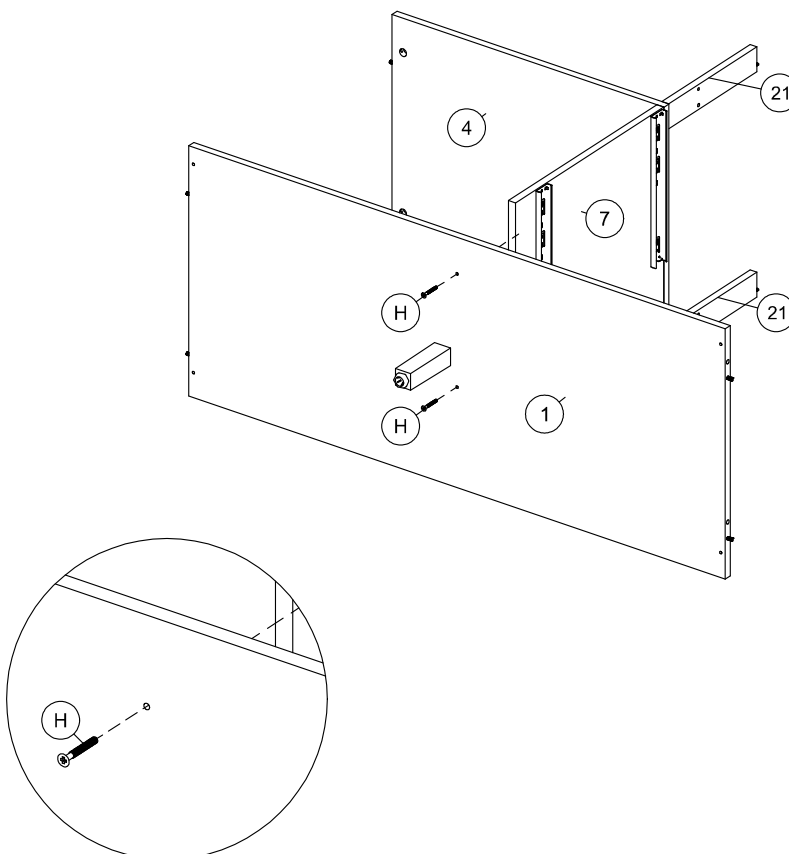
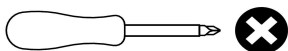



**PASSO 9
STEP 9
PASO 9**

PEÇAS NECESSÁRIAS
PARTS REQUIRED
PIEZAS NECESARIAS

INDICE	QUANT.
3	1
G	2

FERRAGEM NECESSÁRIA
HARDWARE REQUIRED
HERRAMIENTA NECESARIA

INDICE	IMAGEM	QTDE
B		4
H		2

FERRAMENTAS NECESSÁRIAS
TOOL REQUIRED
HERRAMIENTA NECESARIA

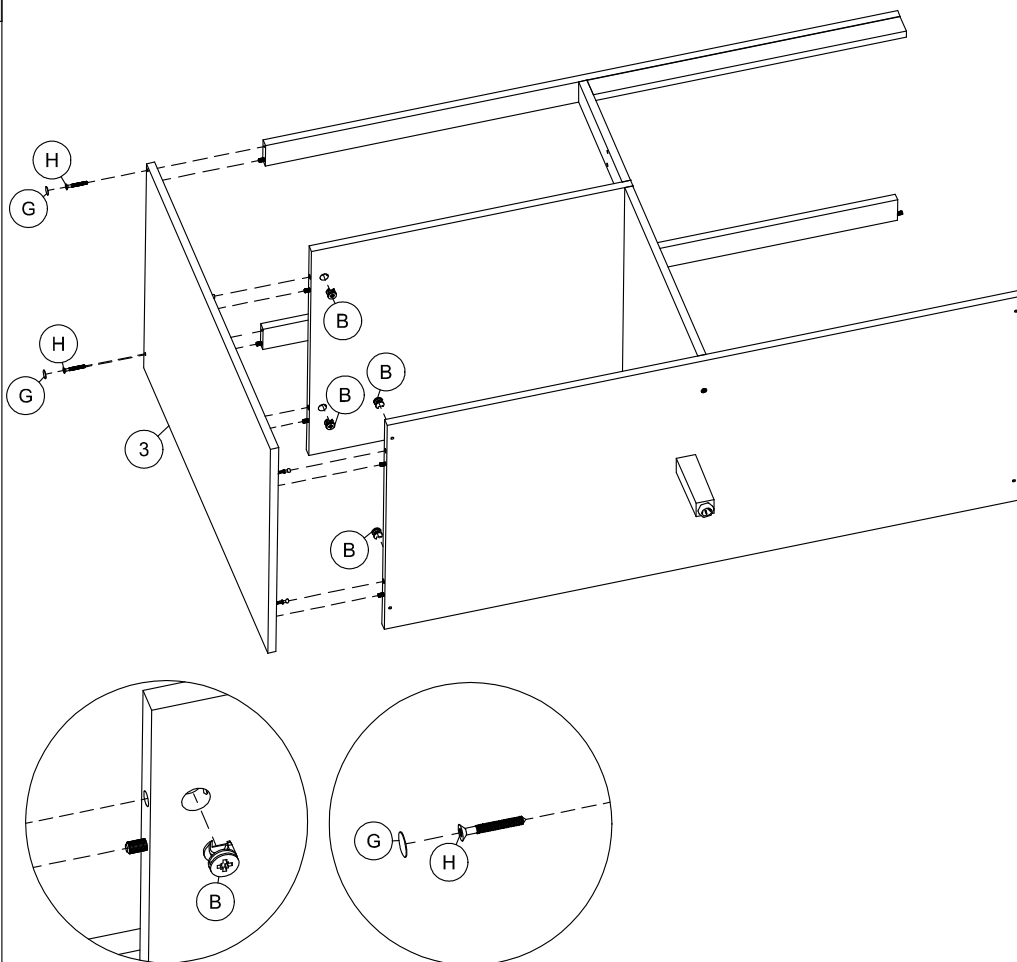
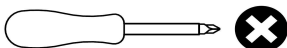

**PASSO 10
STEP 10
PASO 10**

PEÇAS NECESSÁRIAS
PARTS REQUIRED
PIEZAS NECESARIAS

INDICE	QUANT.
16	1

FERRAGEM NECESSÁRIA
HARDWARE REQUIRED
HERRAMIENTA NECESARIA

INDICE	IMAGEM	QTDE
H		1

FERRAMENTAS NECESSÁRIAS
TOOL REQUIRED
HERRAMIENTA NECESARIA

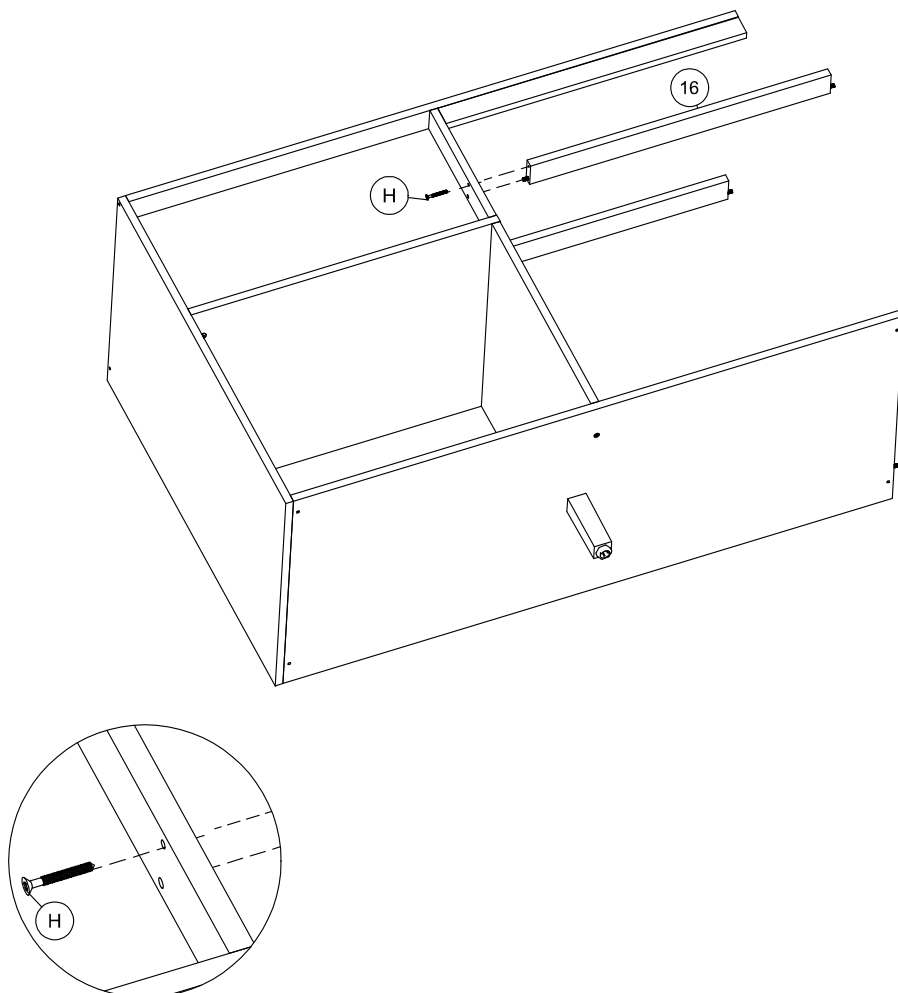
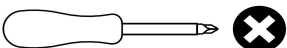

PASSO 11
STEP 11
PASO 11

PEÇAS NECESSÁRIAS
PARTS REQUIRED
PIEZAS NECESARIAS

INDICE	QUANT.
2	1
G	3

FERRAGEM NECESSÁRIA
HARDWARE REQUIRED
HERRAMIENTA NECESARIA

INDICE	IMAGEM	QTDE
B		2
H		3

FERRAMENTAS NECESSÁRIAS
TOOL REQUIRED
HERRAMIENTA NECESARIA

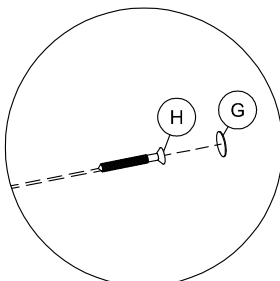
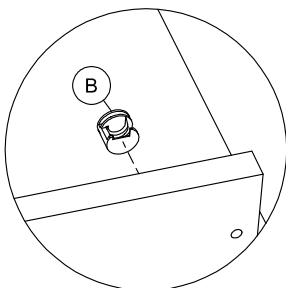
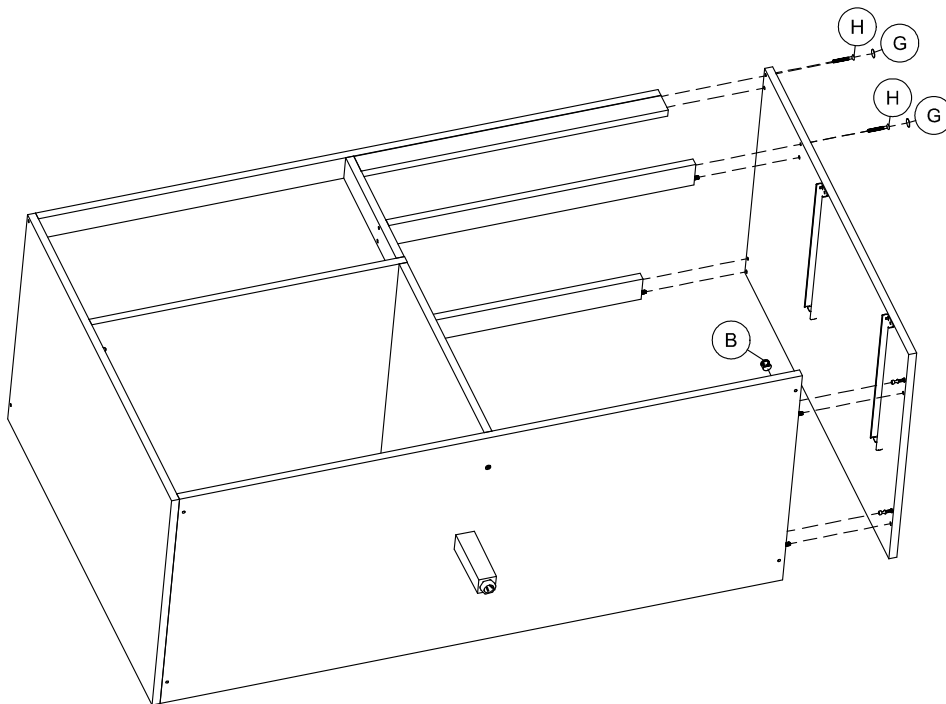
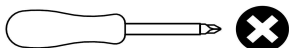

PASSO 12
STEP 12
PASO 12

PEÇAS NECESSÁRIAS
PARTS REQUIRED
PIEZAS NECESARIAS

INDICE	QUANT.
23	4

FERRAGEM NECESSÁRIA
HARDWARE REQUIRED
HERRAMIENTA NECESARIA

INDICE	IMAGEM	QTDE
J		4

FERRAMENTAS NECESSÁRIAS
TOOL REQUIRED
HERRAMIENTA NECESARIA

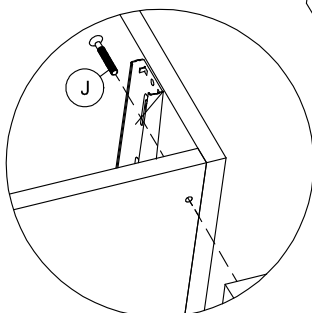
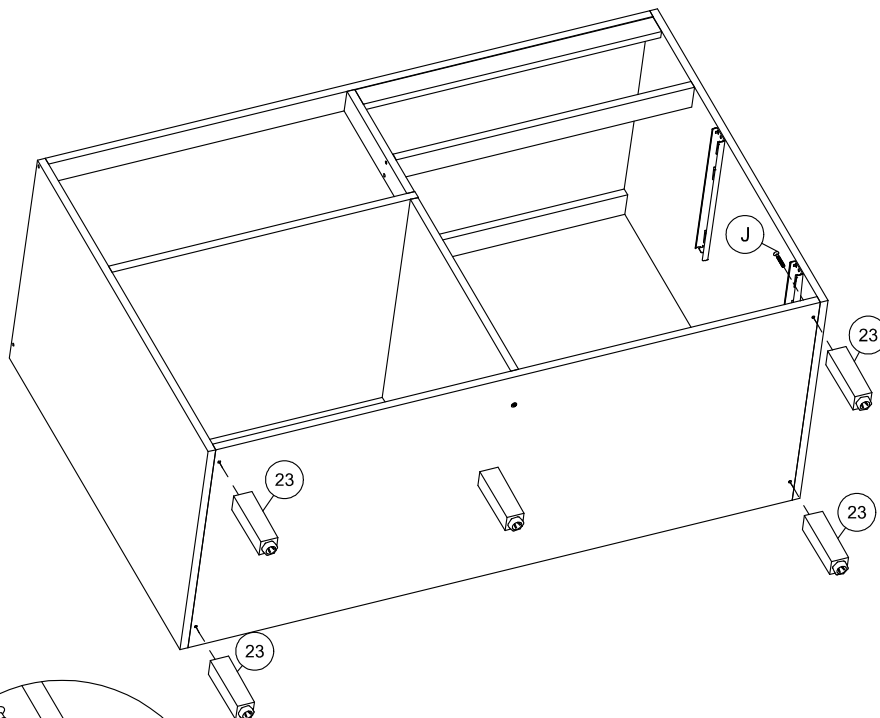
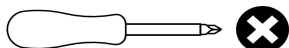





PASSO 13
STEP 13
PASO 13

PEÇAS NECESSÁRIAS
PARTS REQUIRED
PIEZAS NECESARIAS

INDICE	QUANT.
6	2

FERRAGEM NECESSÁRIA
HARDWARE REQUIRED
HERRAMIENTA NECESARIA

INDICE	IMAGEM	QTDE
34		1
C		35
D		5
H		8

FERRAMENTAS NECESSÁRIAS
TOOL REQUIRED
HERRAMIENTA NECESARIA

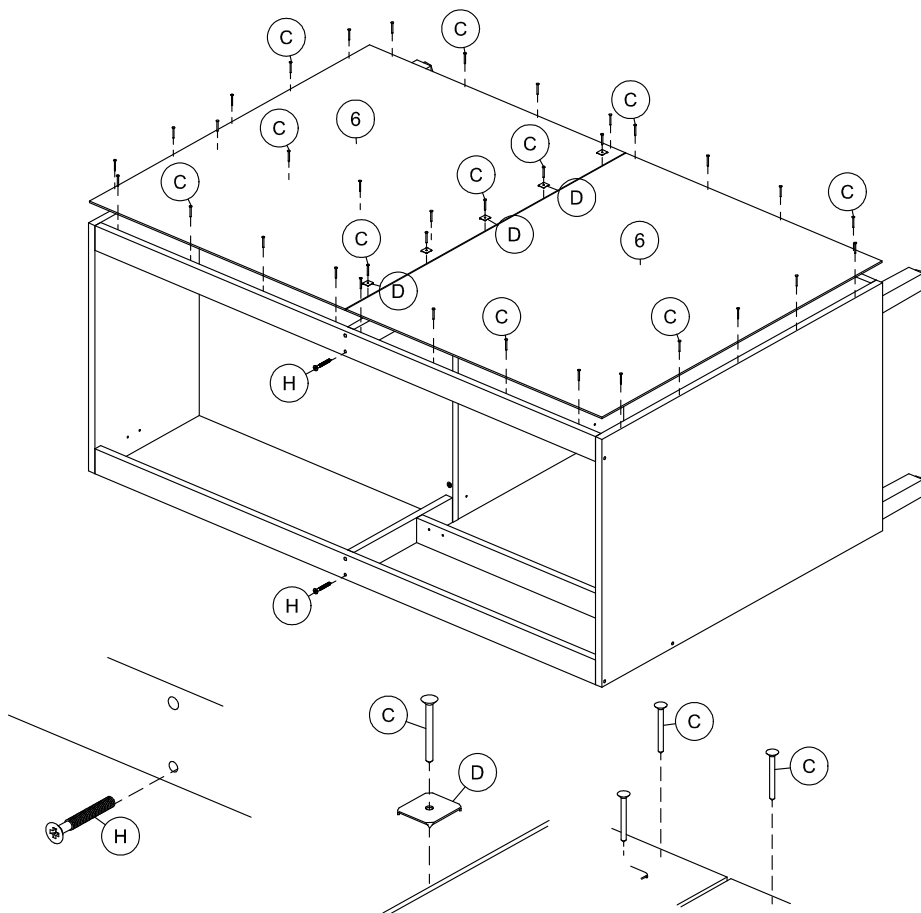
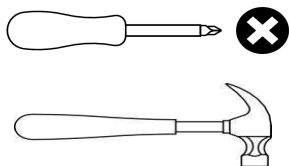

PASSO 14
STEP 14
PASO 14

PEÇAS NECESSÁRIAS
PARTS REQUIRED
PIEZAS NECESARIAS

INDICE	QUANT.
8	1
9	1
10	1
11	1
17	2

FERRAGEM NECESSÁRIA
HARDWARE REQUIRED
HERRAMIENTA NECESARIA

INDICE	IMAGEM	QTDE
F		10

FERRAMENTAS NECESSÁRIAS
TOOL REQUIRED
HERRAMIENTA NECESARIA

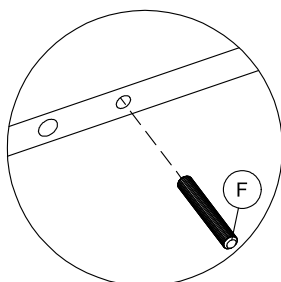
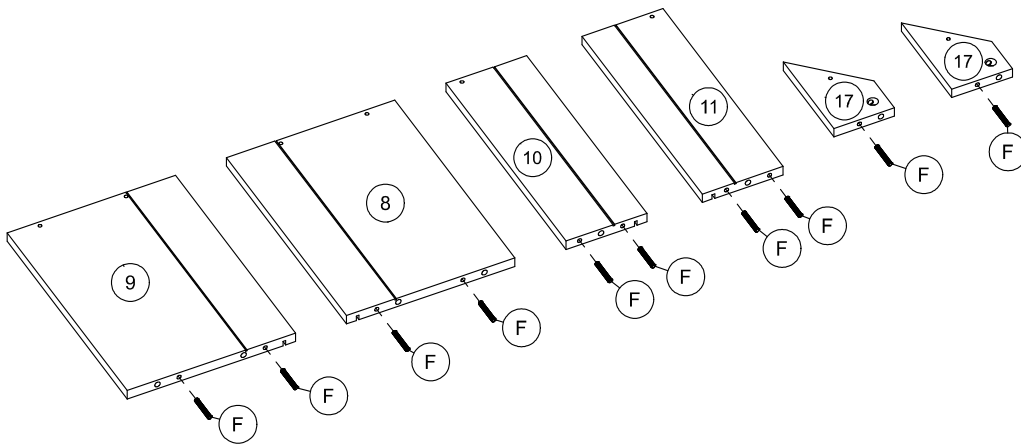
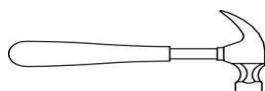

PASSO 15
STEP 15
PASO 15

PEÇAS NECESSÁRIAS
PARTS REQUIRED
PIEZAS NECESARIAS

INDICE	QUANT.
12	1
13	1
15	1

FERRAGEM NECESSÁRIA
HARDWARE REQUIRED
HERRAMIENTA NECESARIA

INDICE	IMAGEM	QTDE
F		10

FERRAMENTAS NECESSÁRIAS
TOOL REQUIRED
HERRAMIENTA NECESARIA

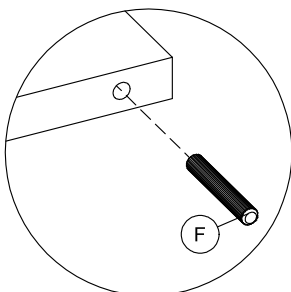
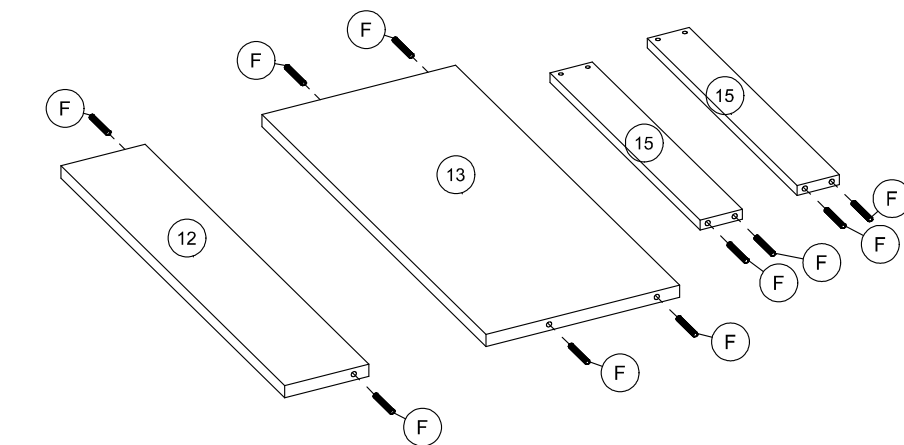
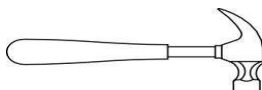



PASSO 16
STEP 16
PASO 16

PEÇAS NECESSÁRIAS
PARTS REQUIRED
PIEZAS NECESARIAS

INDICE	QUANT.
26	1
27	1
29	1
-	1

FERRAGEM NECESSÁRIA
HARDWARE REQUIRED
HERRAMIENTA NECESARIA

INDICE	IMAGEM	QTDE
-		8
A		8

FERRAMENTAS NECESSÁRIAS
TOOL REQUIRED
HERRAMIENTA NECESARIA

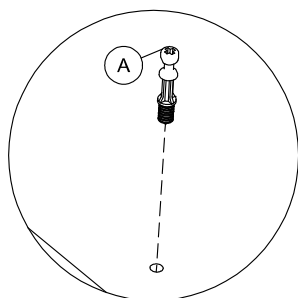
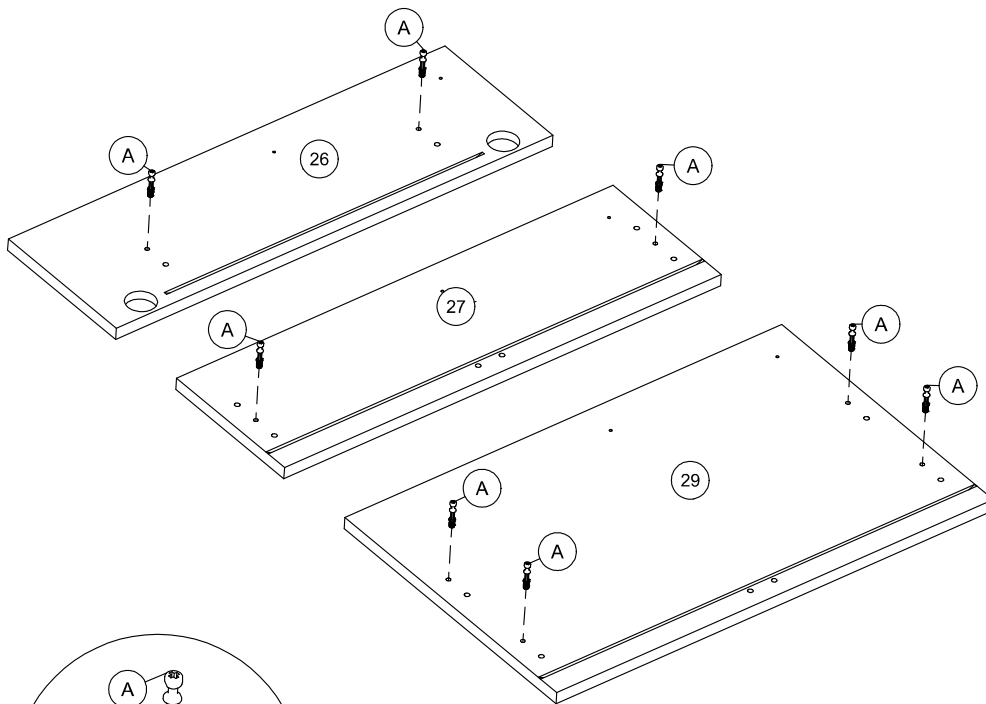
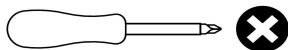

PASSO 17
STEP 17
PASO 17

PEÇAS NECESSÁRIAS
PARTS REQUIRED
PIEZAS NECESARIAS

INDICE	QUANT.
8	1
9	1
10	1
11	1
12	1
13	1
17	2
19	1

FERRAGEM NECESSÁRIA
HARDWARE REQUIRED
HERRAMIENTA NECESARIA

INDICE	IMAGEM	QTDE
H		8

FERRAMENTAS NECESSÁRIAS
TOOL REQUIRED
HERRAMIENTA NECESARIA

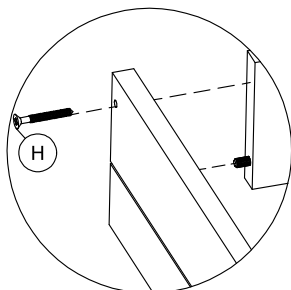
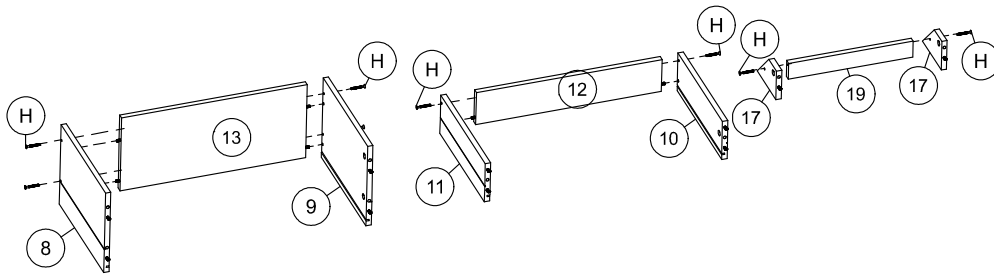
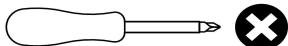

PASSO 18
STEP 18
PASO 18

PEÇAS NECESSÁRIAS
PARTS REQUIRED
PIEZAS NECESARIAS

INDICE	QUANT.
26	1
27	1
29	1
N	8

FERRAGEM NECESSÁRIA
HARDWARE REQUIRED
HERRAMIENTA NECESARIA

INDICE	IMAGEM	QTDE
B		8

FERRAMENTAS NECESSÁRIAS
TOOL REQUIRED
HERRAMIENTA NECESARIA

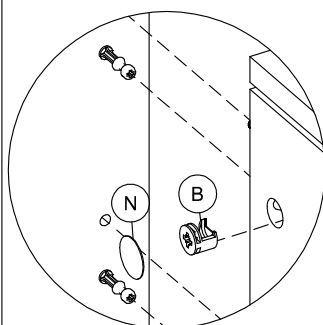
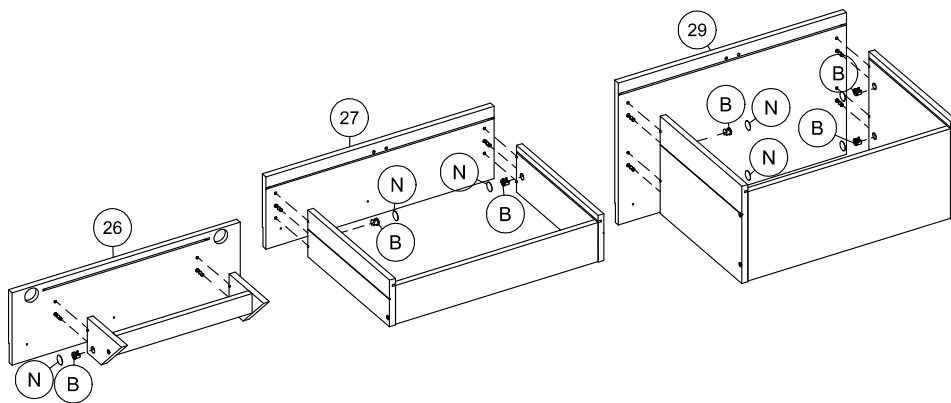
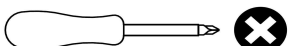

PASSO 19
STEP 19
PASO 19

PEÇAS NECESSÁRIAS
PARTS REQUIRED
PIEZAS NECESARIAS

INDICE	QUANT.
14	2
20	1

FERRAGEM NECESSÁRIA
HARDWARE REQUIRED
HERRAMIENTA NECESSARIA

INDICE	IMAGEM	QTDE
C		20

FERRAMENTAS NECESSÁRIAS
TOOL REQUIRED
HERRAMIENTA NECESSARIA

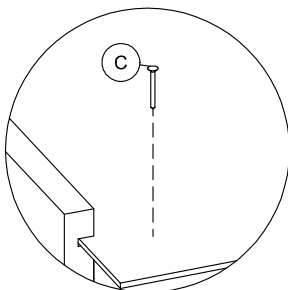
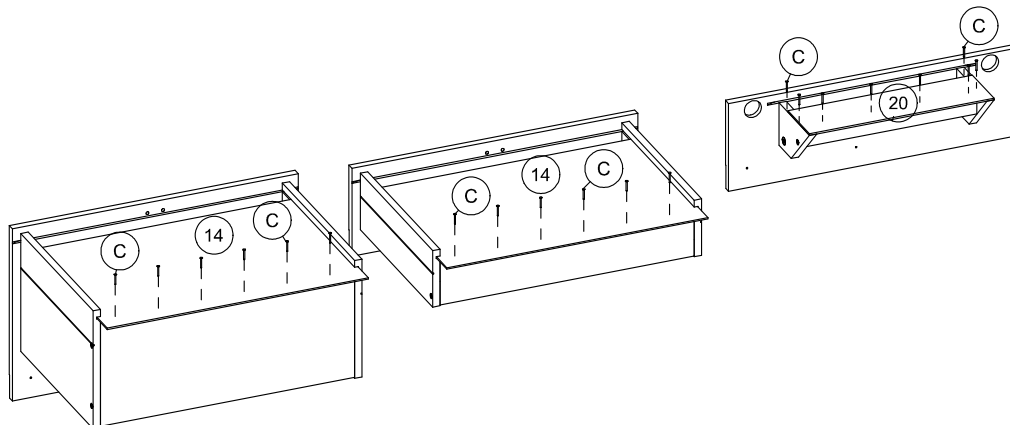
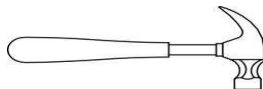



PASSO 20
STEP 20
PASO 20

PEÇAS NECESSÁRIAS
PARTS REQUIRED
PIEZAS NECESARIAS

INDICE	QUANT.
15	2
24	4

FERRAGEM NECESSÁRIA
HARDWARE REQUIRED
HERRAMIENTA NECESSARIA

INDICE	IMAGEM	QTDE
I		8
L		4

FERRAMENTAS NECESSÁRIAS
TOOL REQUIRED
HERRAMIENTA NECESSARIA

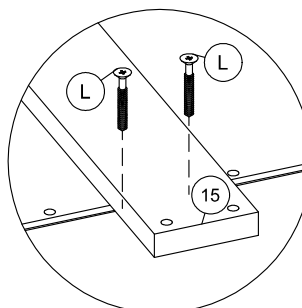
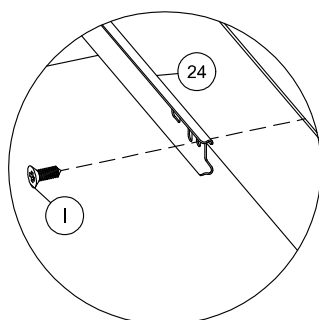
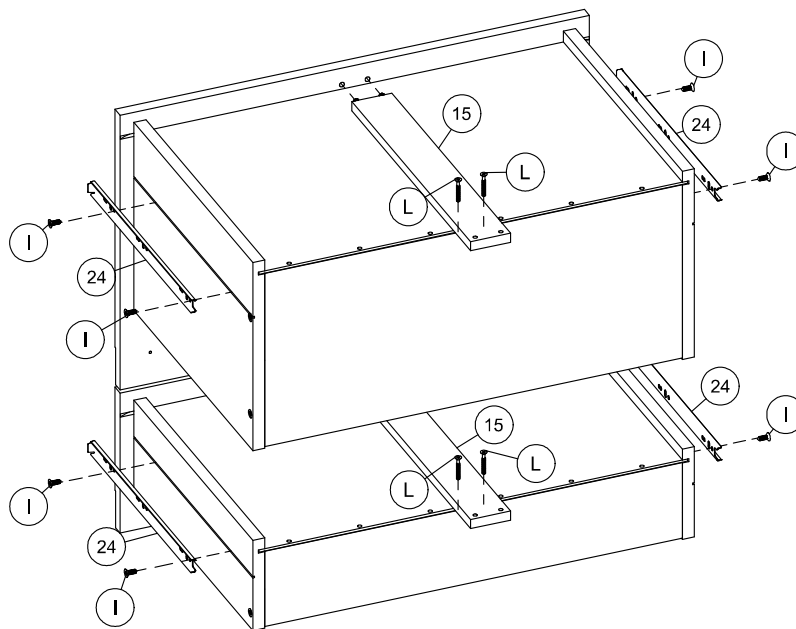
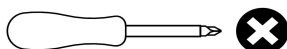



PASSO 21
STEP 21
PASO 21

PEÇAS NECESSÁRIAS
PARTS REQUIRED
PIEZAS NECESARIAS

INDICE	QUANT.
25	1
26	1

FERRAGEM NECESSÁRIA
HARDWARE REQUIRED
HERRAMIENTA NECESARIA

INDICE	IMAGEM	QTDE
I		8
M		4

FERRAMENTAS NECESSÁRIAS
TOOL REQUIRED
HERRAMIENTA NECESARIA

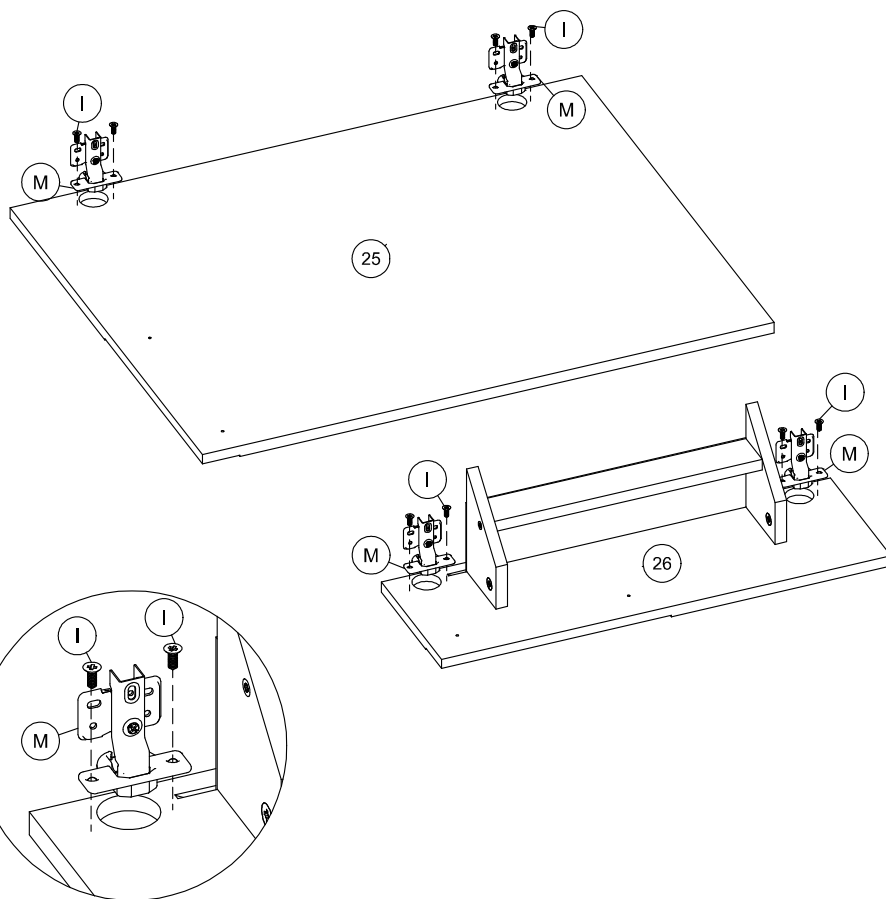
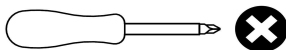



PASSO 22
STEP 22
PASO 22

PEÇAS NECESSÁRIAS
PARTS REQUIRED
PIEZAS NECESARIAS

INDICE	QUANT.
14	1
25	1
26	1
32	1

FERRAGEM NECESSÁRIA
HARDWARE REQUIRED
HERRAMIENTA NECESARIA

INDICE	IMAGEM	QTDE
I		16
K		8
M		4

FERRAMENTAS NECESSÁRIAS
TOOL REQUIRED
HERRAMIENTA NECESARIA

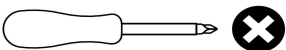

ESTE PARAFUSO É UTILIZADO PARA UNIR OS MOVEIS!
THIS SCREW IS USED TO JOIN THE FURNITURE!
ESTE TORNILLO SE UTILIZA PARA UNIR LOS MUEBLES!

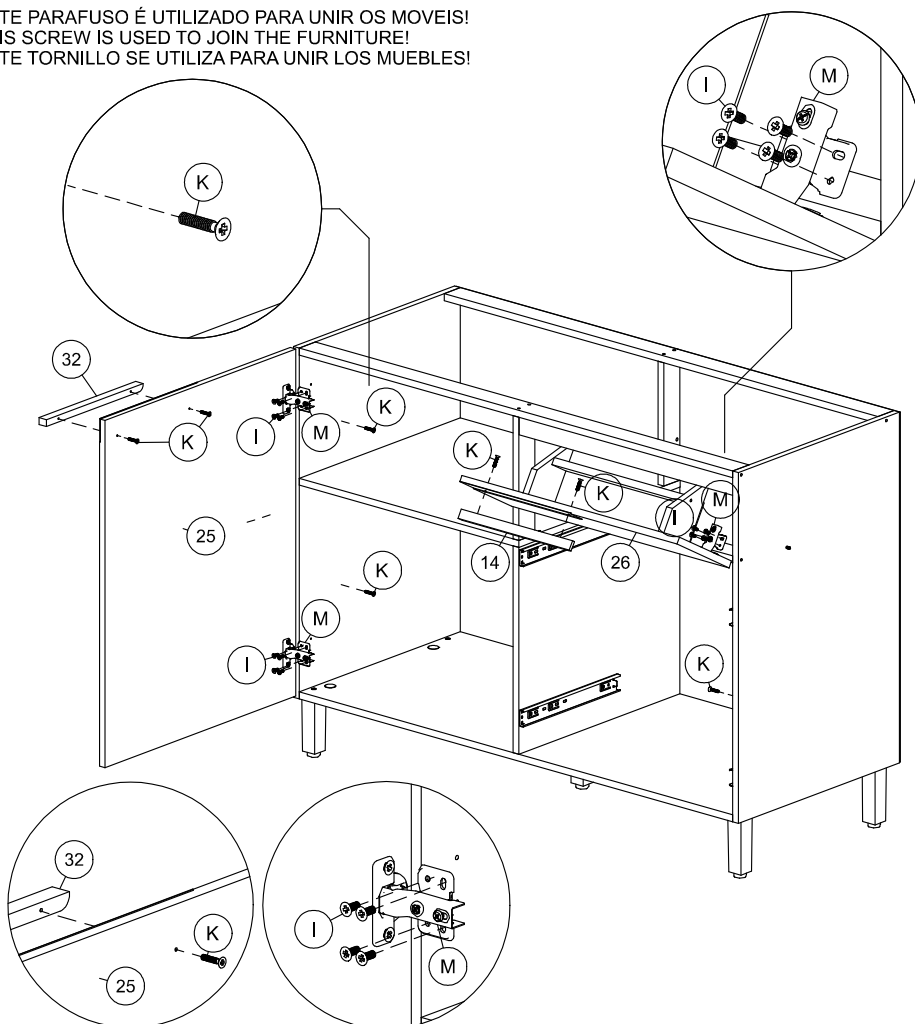

PASSO 23
STEP 23
PASO 23

PEÇAS NECESSÁRIAS
 PARTS REQUIRED
 PIEZAS NECESARIAS

INDICE	QUANT.
14	2
27	1
29	1

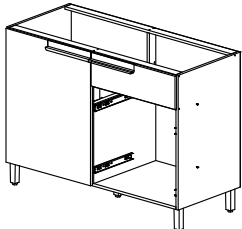

FERRAGEM NECESSÁRIA
 HARDWARE REQUIRED
 HERRAMIENTA NECESSARIA

INDICE	IMAGEM	QTDE
2.11		4

FERRAMENTAS NECESSÁRIAS
 TOOL REQUIRED
 HERRAMIENTA NECESSARIA

