

**BALCÃO 80CM 3 GAV / COUNTER 80CM 3 DRAWERS / MOSTRADOR 80CM 3 CAJONES**  
**PH-3072**

**Montagem**

Recomenda-se a leitura prévia das instruções de montagem e profissionais especializados para montar.

**Assistência**

Caso ocorra problema com algum dos componentes, sublinhe-o, identifique o problema e retorne esta relação, via fax ou outro meio de comunicação disponível para o representante.

-----  
Assinatura do cliente

**Assembly**

Before the assembling is recommended to read carefully the assembly instruction by professional assemblers.

**Assistance**

If happen problems with any component, underline the same, identify the problem and send back this relation immediately, by fax or other way.

-----  
Client signature

**Montaje**

Se recomienda la lectura previa de las instrucciones de montaje y profesionales especializados para montarlos.

**Assistencia**

Caso sucedan problemas con alguno de los componentes, subraye el componente, identifique el problema, y retorne esta copia via fax u otro medio de comunicación posible.

-----  
Assinatura del cliente

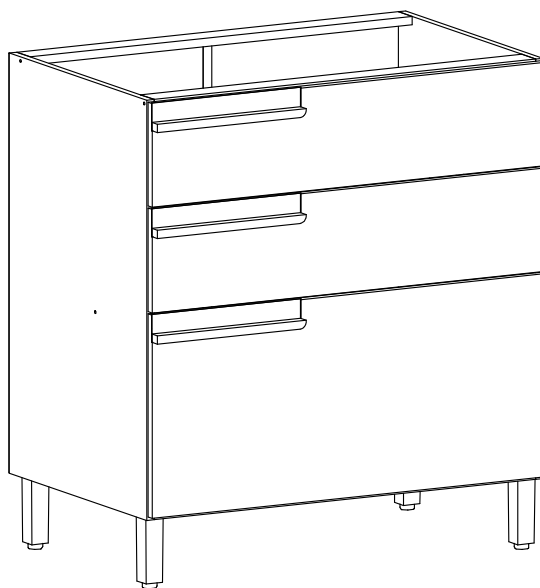

**Atenção / Attention / Atención**

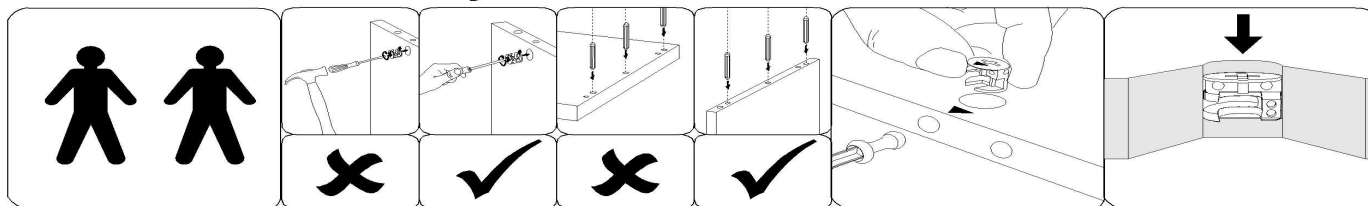

A Heval se reserva o direito de efetuar alterações nos produtos de suas linhas sem aviso prévio, quando entender necessário.

Herval reserves the right to effect modifications in the products, without previous advice, when understand necessary.

Herval se reserva el derecho de hacer las modificaciones que juzgue necesarias en sus productos, sin aviso previo, cuando lo crea necesario.

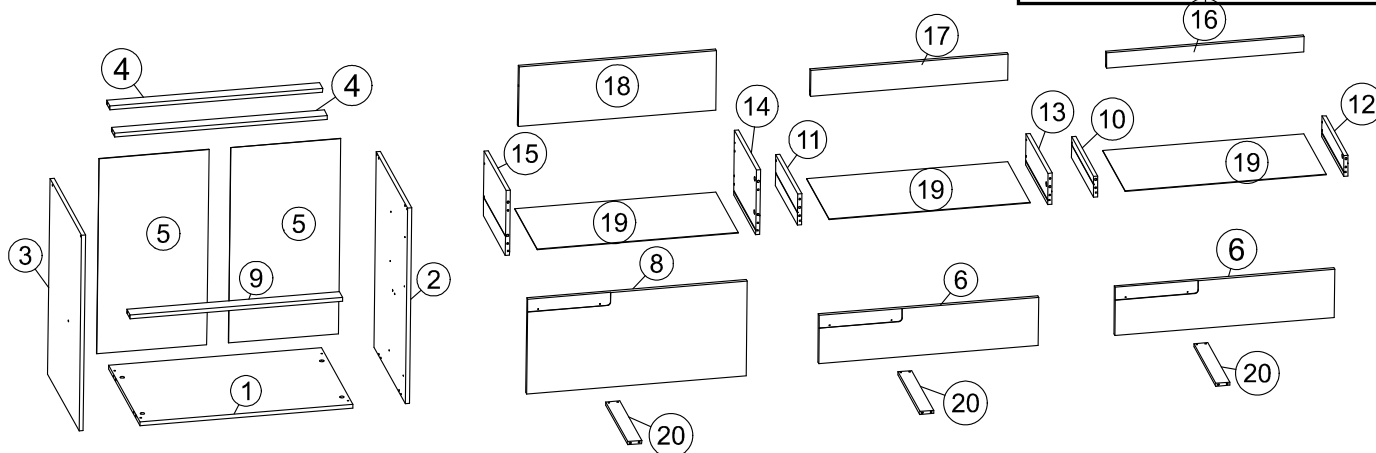
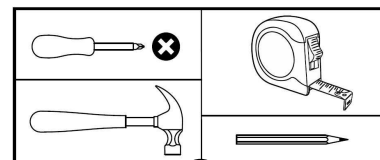

## LISTA DE PEÇAS / PARTS LIST / LISTA DE PIEZAS

### Volume 1 / Carton 1 / Caja 1

ÍNDICE / INDEX	CÓD. / CODE	PEÇA / PART / PIEZA	MED/MEASURE	QTDE / QUANT / CANT
1	159759E	BASE	770.0x500.0x15.0	1
2	159767E	LATERAL DIREITA	755.0x500.0x15.0	1
3	159768E	LATERAL ESQUERDA	755.0x500.0x15.0	1
4	159763E	TRAVESSA TAMPO	770.0x50.0x15.0	2
5	159764E	FUNDO	753.0x398.0x3.0	2
6	159770E	FRENTE GAVETA	794.0x186.0x15.0	2
8	159771E	FRENTE GAV MAIOR	794.0x365.0x15.0	1
9	159772E	TRAVESSA	770.0x50.0x15.0	1
10	159773E	LATERAL GAV ESQ SUPERIOR	350.0x80.0x15.0	1
11	159776E	LATERAL DE GAV. ESQ.	350.0x120.0x15.0	1
12	159774E	LATERAL GAV DIR SUPERIOR	350.0x80.0x15.0	1
13	159777E	LATERAL DE GAV. DIR.	350.0x120.0x15.0	1
14	159778E	LATERAL DE GAV. DIR. MAIOR	350.0x250.0x15.0	1
14	1609851	PUXADOR DIREITO MANHATTAN	300.3x15.0x20.0	3
15	159779E	LATERAL DE GAV. ESQ. MAIOR	350.0x250.0x15.0	1
16	159775E	TRASEIRO GAV. SUPERIOR	714.0x60.0x15.0	1
17	159781E	TRASEIRO DE GAVETA	714.0x100.0x15.0	1
18	159780E	TRASEIRO DE GAVETA MAIOR	714.0x230.0x15.0	1
19	159782E	FUNDO DE GAVETA	357.0x728.0x3.0	3
20	159783E	SUPORTE GAVETA	350.0x50.0x12.0	3
21	XXXXXXX	PERFIL I 723X20X3,8MM CINZA ALUM001	723.0x17.0x6.0	1
23	1609550	PÉ C/ SAPATA REGULÁVEL PLÁSTICA 0203420	xx	4
24	1609590	CORRED TRIL TELESC LIGHT 300MM	xx	6
25	K072722	KIT PH3072 MÓD. BALCÃO 80CM 3 GAV.	xx	1
E	-	TAPA FURO ADESIVO PAPEL 15mm	15.0x15.0x0.5	6
K	XXXXXXX	TAPA FURO ADESIVO PAPEL 20MM	22.0x22.0x0.5	8

### LISTA DE ACESSÓRIOS / FITTINGS LIST / LISTA DE ACCESORIOS

REF.	PEÇA	PART	PIEZA	QTDE	CÓDIGO
A	PARAFUSO MINIFIX	Cam Bolt 32xØ6mm	Perno de Leva 32xØ6mm	12	1602006
B	TAMBOR MINIFIX Ø14.9X11MM	Can Nut Ø15 mm	Porca de Leva Ø15 mm	12	1605358
C	PREGO 10 X 10 C/CABEÇA - Ø1,5 x 23mm	Nail 10 X 10 - Ø1,5 x 23mm	Clavo 10 X 10	44	1605365
D	CAVILHA DE MADEIRA 6X40	Dowel Ø6 x 40 mm	Tarugo Ø6 x 40 mm	34	1604742
F	PARAFUSO 4 X 40 CAB. CHATA PHILIPS	Screw Ø4 x 40 mm	Tornillo Ø4 x 40 mm	14	1604937
G	PARAFUSO 4 X 14 CAB. CHATA REBAIXADA PHILIPS	Screw Ø4 x 14 mm	Tornillo Ø4 x 14 mm	24	1602420
H	PARAFUSO 4.5 X 35 CAB. CHATA PHILIPS	Screw Ø4.5 x 35 mm	Tornillo Ø4.5 x 35 mm	4	4,5x35
I	PARAFUSO 4 X 25 CAB. CHATA PHILIPS	Screw Ø4 x 25 mm	Tornillo Ø4 x 25 mm	10	1607862
J	PARAFUSO 3 X 30 CAB. CHATA PHILIPS	Screw Ø3 x 30 mm	Tornillo Ø3 x 30 mm	6	1607848

**PASSO 1  
STEP 1  
PASO 1**

PEÇAS NECESSÁRIAS  
PARTS REQUIRED  
PIEZAS NECESARIAS

INDICE	QUANT.
1	1
4	2
9	1

FERRAGEM NECESSÁRIA  
HARDWARE REQUIRED  
HERRAMIENTA NECESSARIA

INDICE	IMAGEM	QTDE
D		10

FERRAMENTAS NECESSÁRIAS  
TOOL REQUIRED  
HERRAMIENTA NECESSARIA

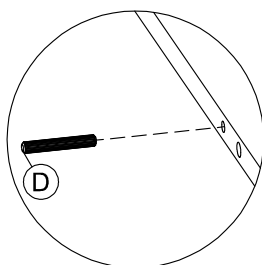
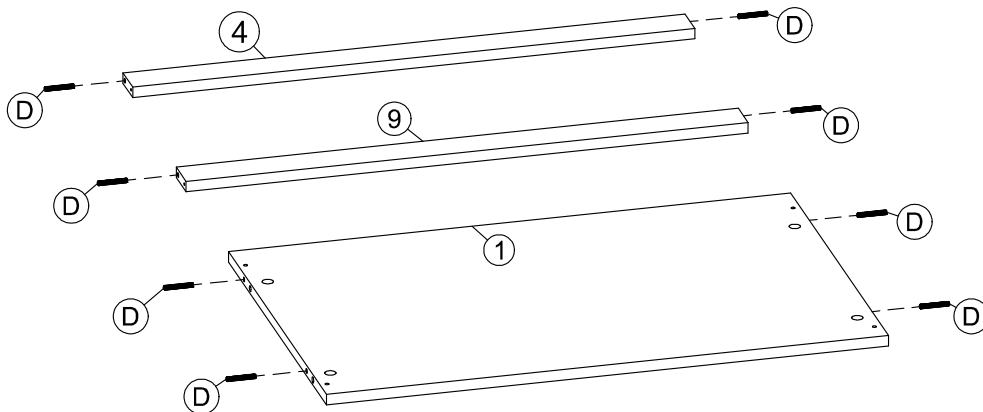
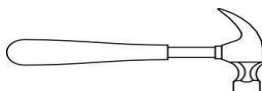



**PASSO 2  
STEP 2  
PASO 2**

PEÇAS NECESSÁRIAS  
PARTS REQUIRED  
PIEZAS NECESARIAS

INDICE	QUANT.
2	1
3	1
24	6

FERRAGEM NECESSÁRIA  
HARDWARE REQUIRED  
HERRAMIENTA NECESSARIA

INDICE	IMAGEM	QTDE
A		4
G		12

FERRAMENTAS NECESSÁRIAS  
TOOL REQUIRED  
HERRAMIENTA NECESSARIA

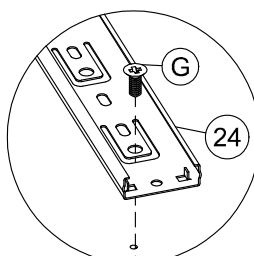
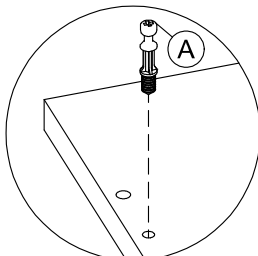
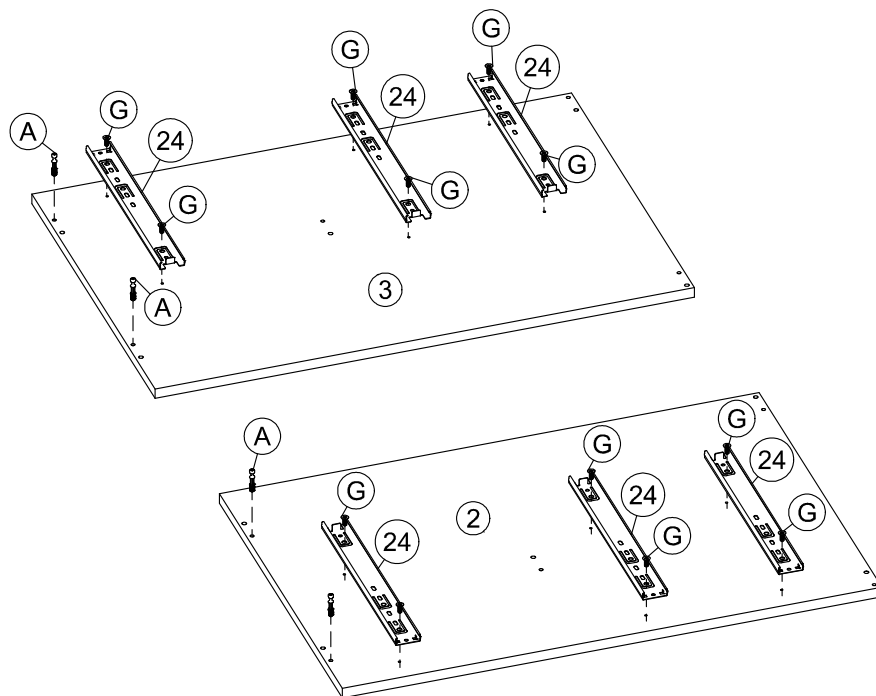
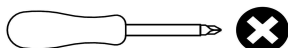



**PASSO 3  
STEP 3  
PASO 3**

PEÇAS NECESSÁRIAS  
PARTS REQUIRED  
PIEZAS NECESARIAS

INDICE	QUANT.
1	1
3	1
4	2
9	1
E	4

FERRAGEM NECESSÁRIA  
HARDWARE REQUIRED  
HERRAMIENTA NECESARIA

INDICE	IMAGEM	QTDE
B		4
F		6

FERRAMENTAS NECESSÁRIAS  
TOOL REQUIRED  
HERRAMIENTA NECESARIA

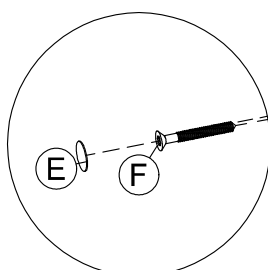
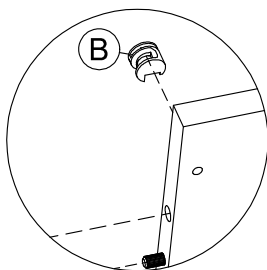
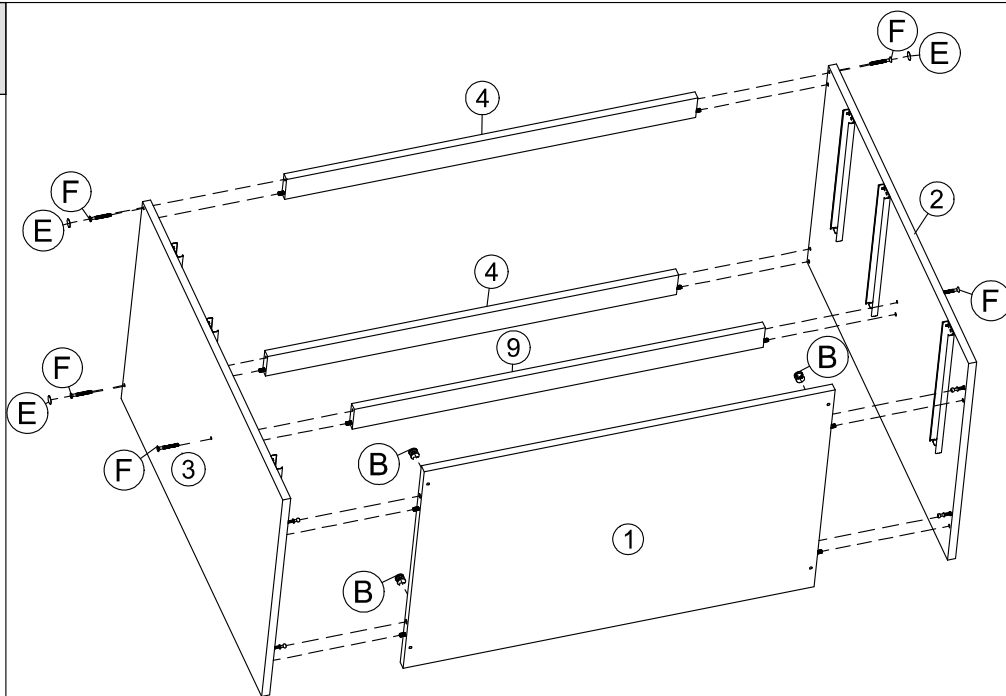
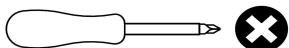

**PASSO 4  
STEP 4  
PASO 4**

PEÇAS NECESSÁRIAS  
PARTS REQUIRED  
PIEZAS NECESARIAS

INDICE	QUANT.
23	4

FERRAGEM NECESSÁRIA  
HARDWARE REQUIRED  
HERRAMIENTA NECESARIA

INDICE	IMAGEM	QTDE
H		4

FERRAMENTAS NECESSÁRIAS  
TOOL REQUIRED  
HERRAMIENTA NECESARIA

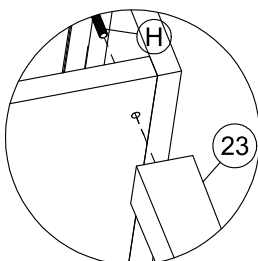
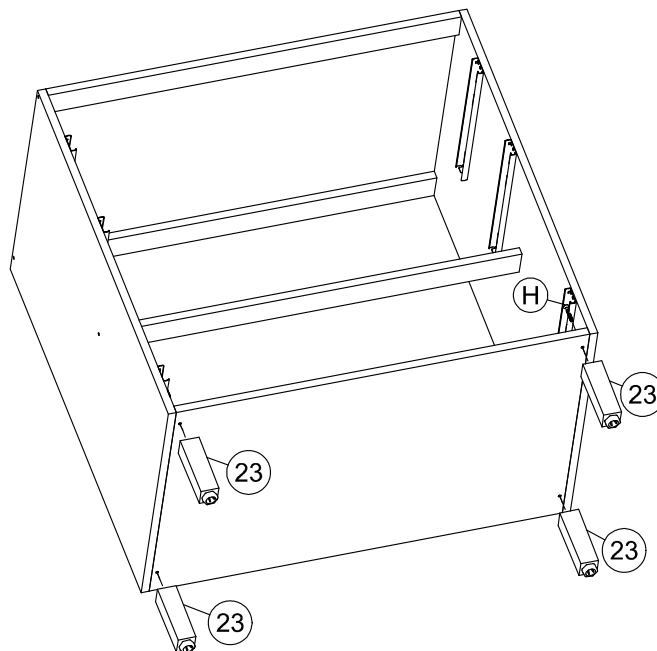
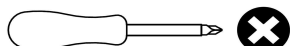

**PASSO 5  
STEP 5  
PASO 5**

PEÇAS NECESSÁRIAS  
PARTS REQUIRED  
PIEZAS NECESARIAS

INDICE	QUANT.
5	2
21	1

FERRAGEM NECESSÁRIA  
HARDWARE REQUIRED  
HERRAMIENTA NECESARIA

INDICE	IMAGEM	QTDE
C		26

FERRAMENTAS NECESSÁRIAS  
TOOL REQUIRED  
HERRAMIENTA NECESARIA

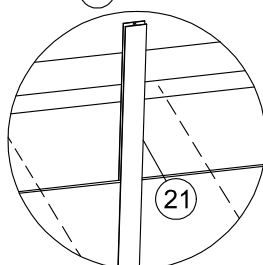
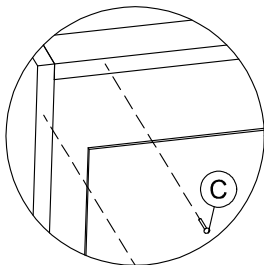
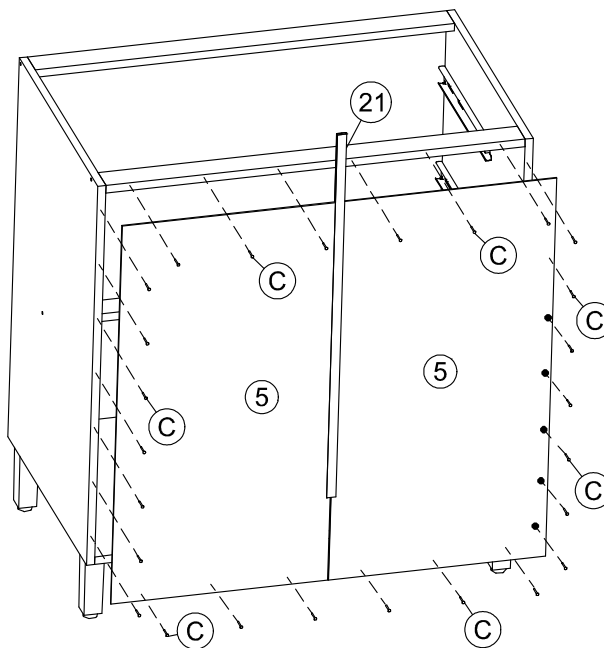
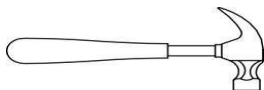

**PASSO 6  
STEP 6  
PASO 6**

PEÇAS NECESSÁRIAS  
PARTS REQUIRED  
PIEZAS NECESARIAS

INDICE	QUANT.
10	1
11	1
12	1
13	1
14	1
15	1

FERRAGEM NECESSÁRIA  
HARDWARE REQUIRED  
HERRAMIENTA NECESARIA

INDICE	IMAGEM	QTDE
D		10

FERRAMENTAS NECESSÁRIAS  
TOOL REQUIRED  
HERRAMIENTA NECESARIA

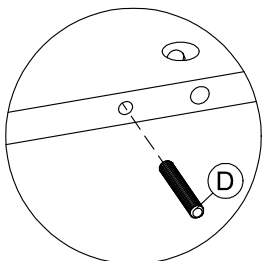
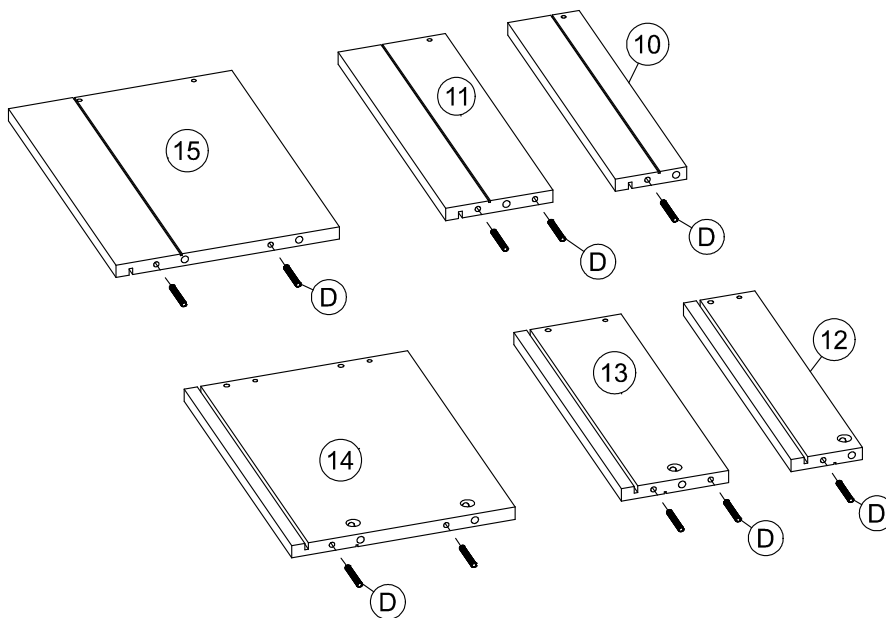
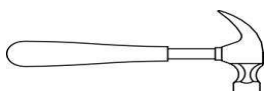

**PASSO 7  
STEP 7  
PASO 7**

PEÇAS NECESSÁRIAS  
PARTS REQUIRED  
PIEZAS NECESARIAS

INDICE	QUANT.
16	1
17	1
18	1
20	3

FERRAGEM NECESSÁRIA  
HARDWARE REQUIRED  
HERRAMIENTA NECESARIA

INDICE	IMAGEM	QTDE
D		14

FERRAMENTAS NECESSÁRIAS  
TOOL REQUIRED  
HERRAMIENTA NECESARIA

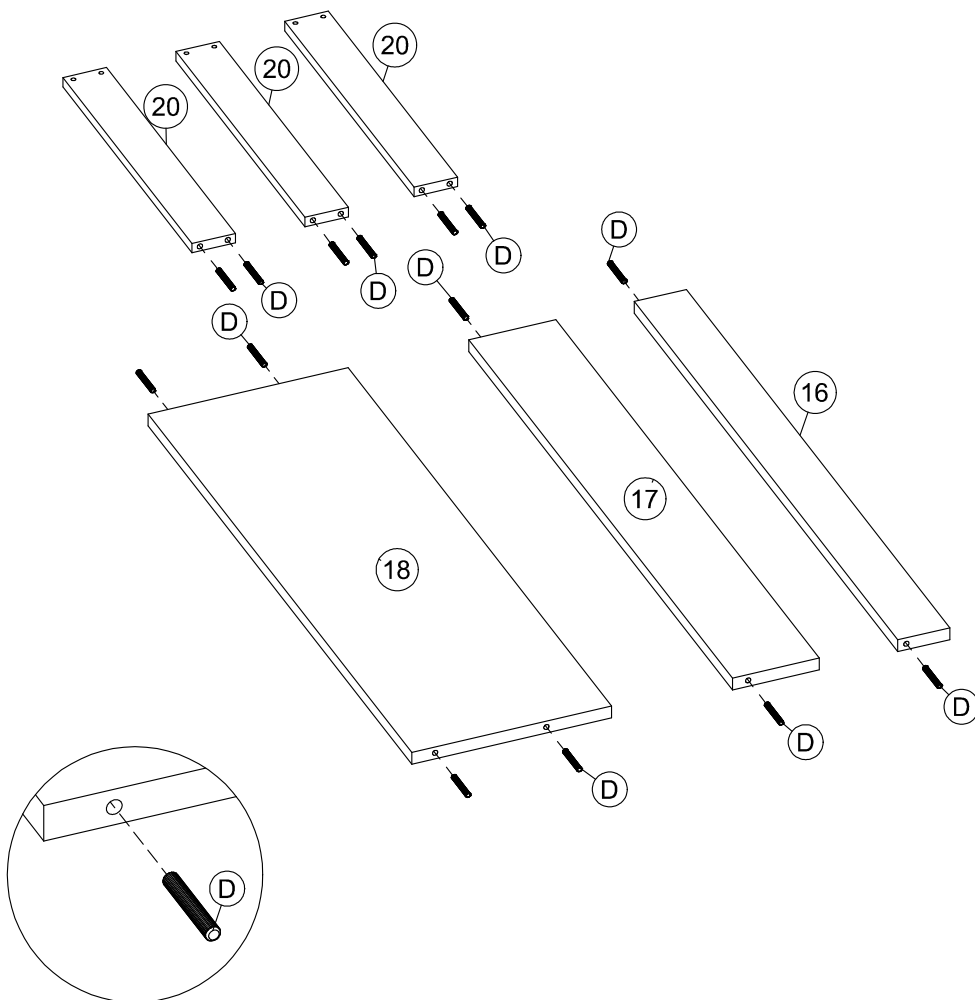
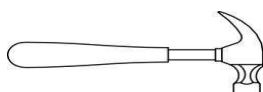

**PASSO 8  
STEP 8  
PASO 8**

PEÇAS NECESSÁRIAS  
PARTS REQUIRED  
PIEZAS NECESARIAS

INDICE	QUANT.
6	2
8	1

FERRAGEM NECESSÁRIA  
HARDWARE REQUIRED  
HERRAMIENTA NECESARIA

INDICE	IMAGEM	QTDE
A		8

FERRAMENTAS NECESSÁRIAS  
TOOL REQUIRED  
HERRAMIENTA NECESARIA

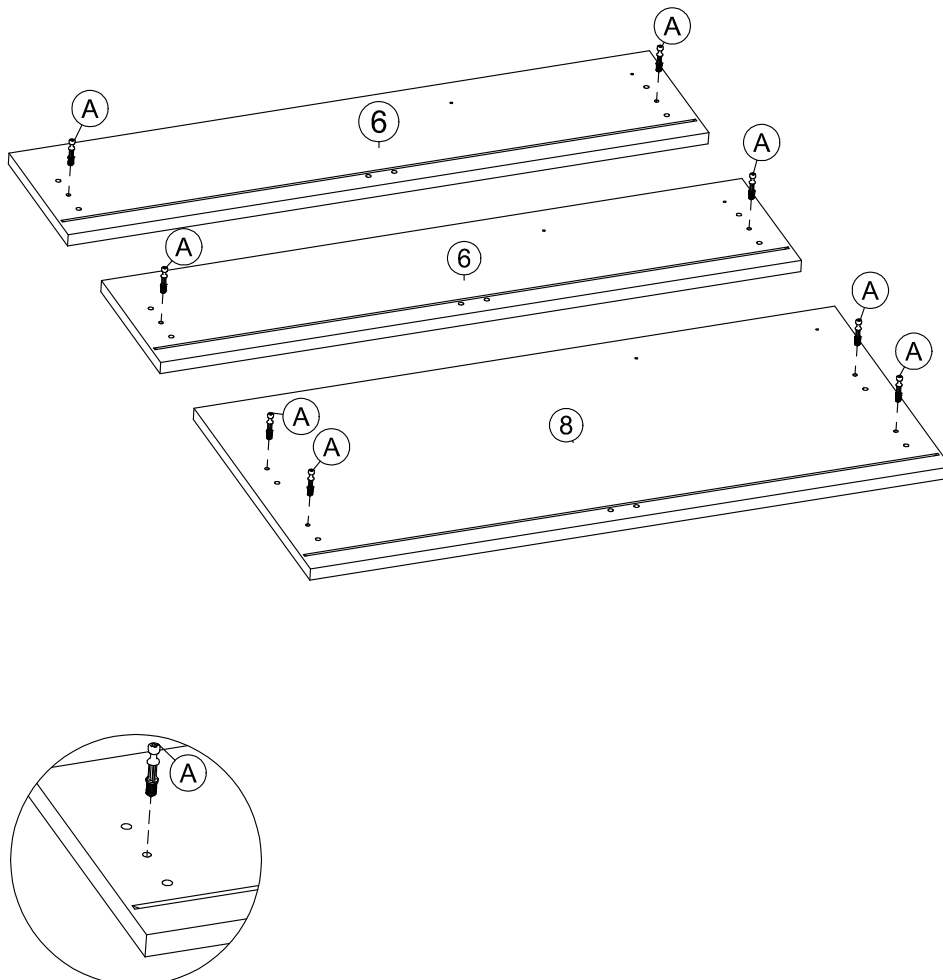
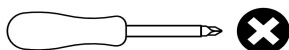

**PASSO 9  
STEP 9  
PASO 9**

PEÇAS NECESSÁRIAS  
PARTS REQUIRED  
PIEZAS NECESARIAS

INDICE	QUANT.
10	1
11	1
12	1
13	1
14	1
15	1
16	1
17	1
18	1

FERRAGEM NECESSÁRIA  
HARDWARE REQUIRED  
HERRAMIENTA NECESARIA

INDICE	IMAGEM	QTDE
F		8

FERRAMENTAS NECESSÁRIAS  
TOOL REQUIRED  
HERRAMIENTA NECESARIA

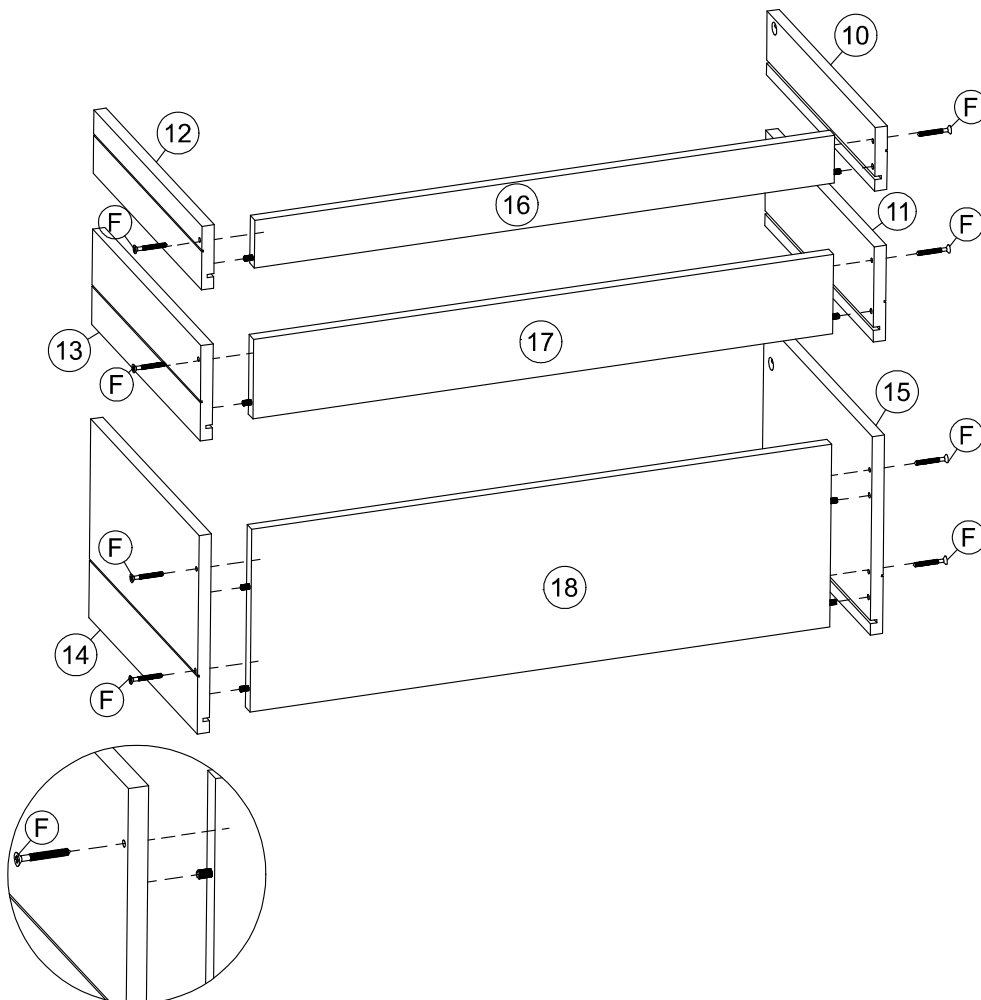
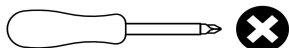

**PASSO 10  
STEP 10  
PASO 10**

PEÇAS NECESSÁRIAS  
PARTS REQUIRED  
PIEZAS NECESARIAS

INDICE	QUANT.
6	2
8	1
K	8

FERRAGEM NECESSÁRIA  
HARDWARE REQUIRED  
HERRAMIENTA NECESARIA

INDICE	IMAGEM	QTDE
B		8

FERRAMENTAS NECESSÁRIAS  
TOOL REQUIRED  
HERRAMIENTA NECESARIA

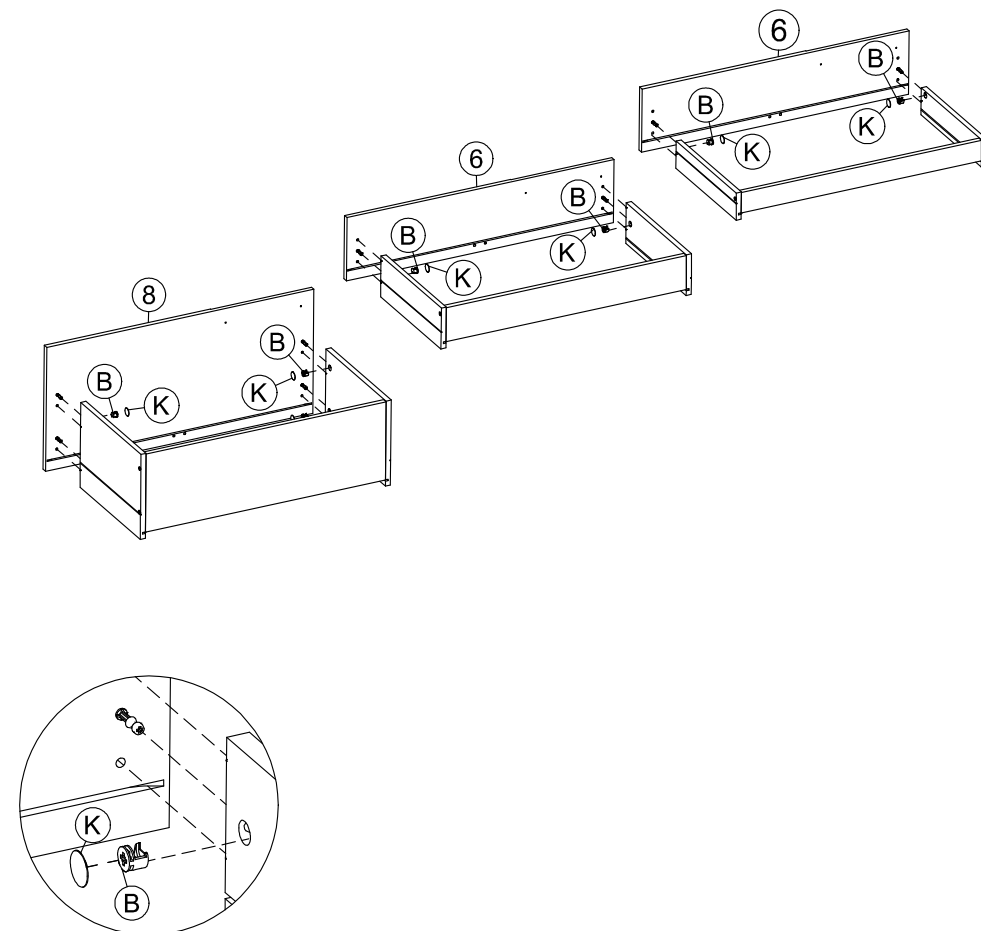
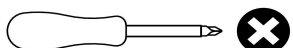

**PASSO 11**  
**STEP 11**  
**PASO 11**

PEÇAS NECESSÁRIAS  
PARTS REQUIRED  
PIEZAS NECESARIAS

INDICE	QUANT.
19	3

FERRAGEM NECESSÁRIA  
HARDWARE REQUIRED  
HERRAMIENTA NECESARIA

INDICE	IMAGEM	QTDE
C		18

FERRAMENTAS NECESSÁRIAS  
TOOL REQUIRED  
HERRAMIENTA NECESARIA

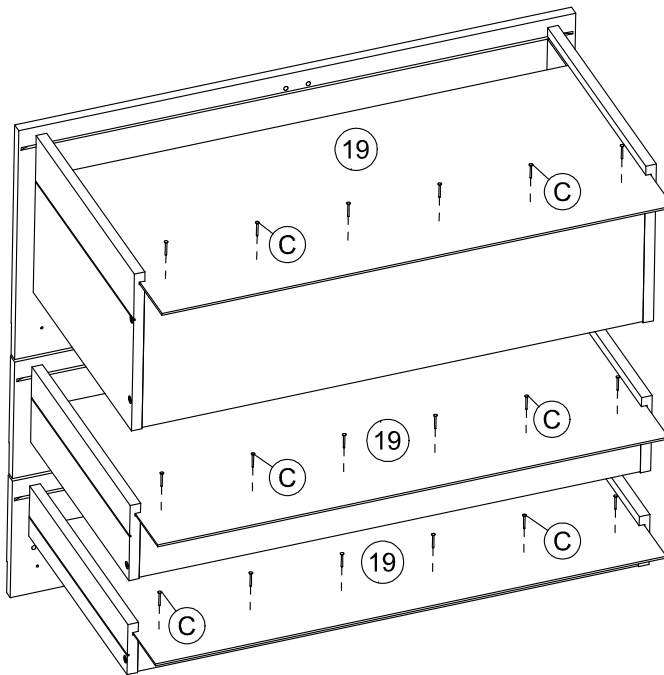
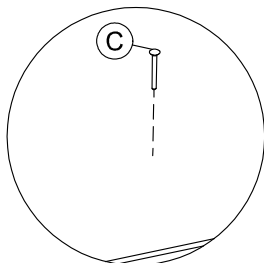
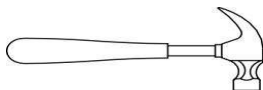

**PASSO 12**  
**STEP 12**  
**PASO 12**

PEÇAS NECESSÁRIAS  
PARTS REQUIRED  
PIEZAS NECESARIAS

INDICE	QUANT.
20	3

FERRAGEM NECESSÁRIA  
HARDWARE REQUIRED  
HERRAMIENTA NECESARIA

INDICE	IMAGEM	QTDE
J		6

FERRAMENTAS NECESSÁRIAS  
TOOL REQUIRED  
HERRAMIENTA NECESARIA

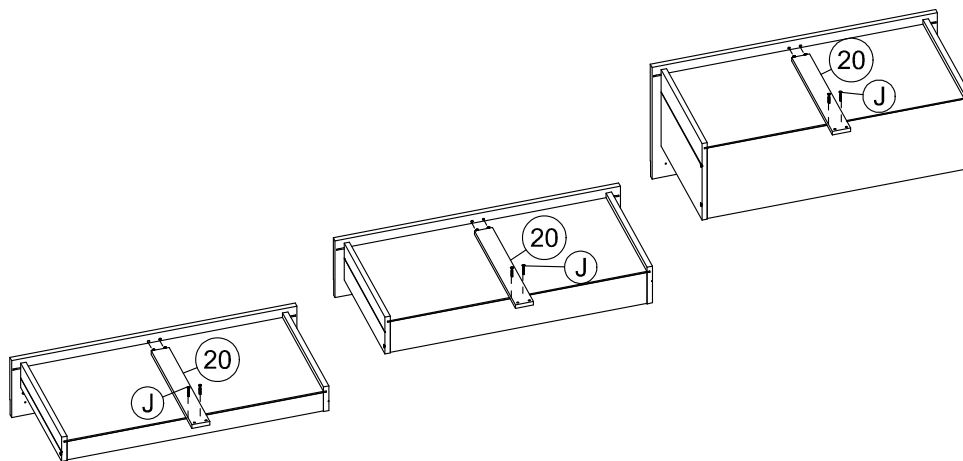
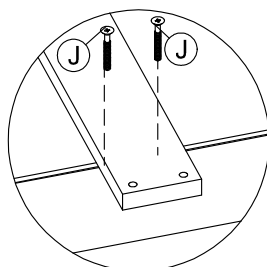
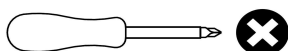



**PASSO 13**  
**STEP 13**  
**PASO 13**

PEÇAS NECESSÁRIAS  
PARTS REQUIRED  
PIEZAS NECESARIAS

INDICE	QUANT.
24	6

FERRAGEM NECESSÁRIA  
HARDWARE REQUIRED  
HERRAMIENTA NECESARIA

INDICE	IMAGEM	QTDE
G		12

FERRAMENTAS NECESSÁRIAS  
TOOL REQUIRED  
HERRAMIENTA NECESARIA

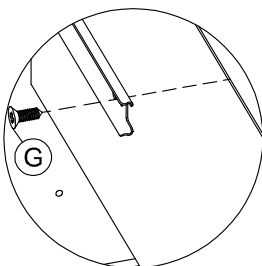
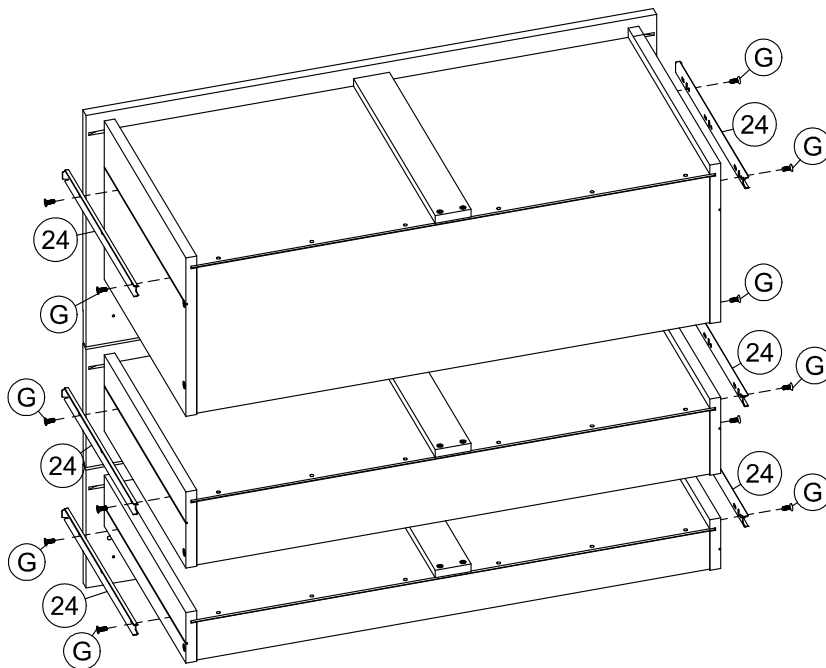
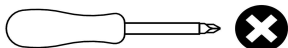

**PASSO 14**  
**STEP 14**  
**PASO 14**

PEÇAS NECESSÁRIAS  
PARTS REQUIRED  
PIEZAS NECESARIAS

INDICE	IMAGEM	QTDE
E		4

FERRAGEM NECESSÁRIA  
HARDWARE REQUIRED  
HERRAMIENTA NECESARIA

INDICE	IMAGEM	QTDE
E		4

FERRAMENTAS NECESSÁRIAS  
TOOL REQUIRED  
HERRAMIENTA NECESARIA

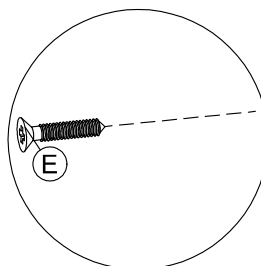
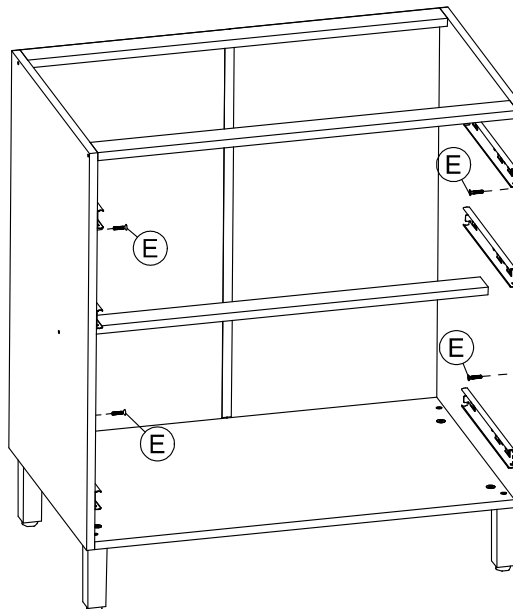
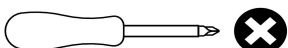

ESTE PARAFUSO É UTILIZADO PRA FIXAÇÃO ENTRE OS MÓDULOS  
THIS SCREW IS USED FOR FIXING BETWEEN THE MODULES  
ESTE TORNILLO SE UTILIZA PARA LA FIJACIÓN ENTRE LOS MÓDULOS

**PASSO 15**  
**STEP 15**  
**PASO 15**

PEÇAS NECESSÁRIAS  
 PARTS REQUIRED  
 PIEZAS NECESSARIAS

INDICE	QUANT.
14	3

FERRAGEM NECESSÁRIA  
 HARDWARE REQUIRED  
 HERRAMIENTA NECESSARIA

INDICE	IMAGEM	QTDE
I		6

FERRAMENTAS NECESSÁRIAS  
 TOOL REQUIRED  
 HERRAMIENTA NECESSARIA

