

BALCÃO 80CM 2 PORTAS / COUNTER 80CM 2 DOORS / MOSTRADOR 80CM 2 PUERTAS
PH-3071

Montagem

Recomenda-se a leitura prévia das instruções de montagem e profissionais especializados para montar.

Assistência

Caso ocorra problema com algum dos componentes, sublinhe-o, identifique o problema e retorne esta relação, via fax ou outro meio de comunicação disponível para o representante.

Assinatura do cliente

Assembly

Before the assembling is recommended to read carefully the assembly instruction by professional assemblers.

Assistance

If happen problems with any component, underline the same, identify the problem and send back this relation immediately, by fax or other way.

Client signature

Montaje

Se recomienda la lectura previa de las instrucciones de montaje y profesionales especializados para montarlos.

Assistencia

Caso sucedan problemas con alguno de los componentes, subraye el componente, identifique el problema, y retorne esta copia via fax u otro medio de comunicación posible.

Assinatura del cliente

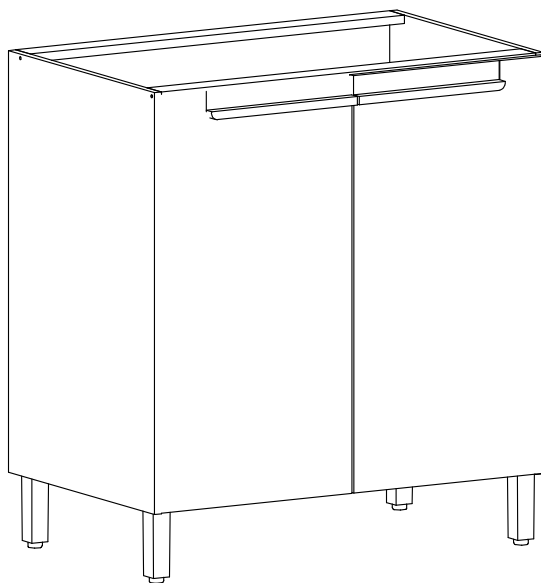

Atenção / Attention / Atención

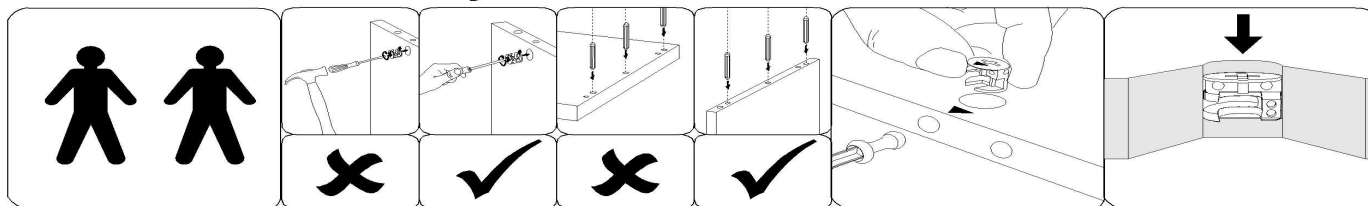

A Heval se reserva o direito de efetuar alterações nos produtos de suas linhas sem aviso prévio, quando entender necessário.

Herval reserves the right to effect modifications in the products, without previous advice, when understand necessary.

Herval se reserva el derecho de hacer las modificaciones que juzgue necesarias en sus productos, sin aviso previo, cuando lo crea necesario.

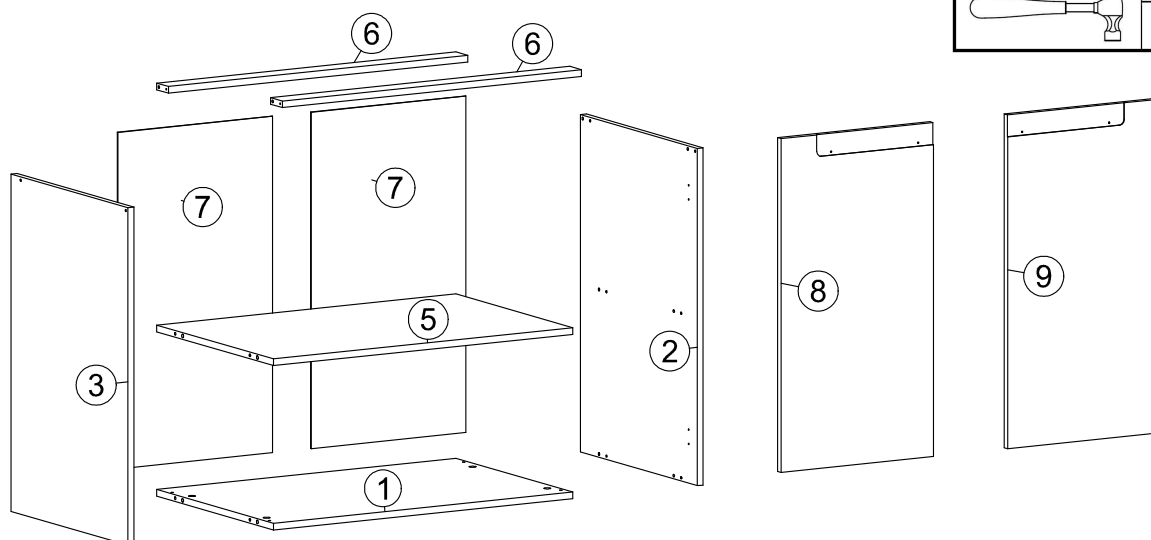

LISTA DE PEÇAS / PARTS LIST / LISTA DE PIEZAS

Volume 1 / Carton 1 / Caja 1

ÍNDICE/_INDEX	CÓD./_CODE	PEÇA/_PART/_PIEZA	MED/MEASURE	QTDE/_QUANT/_CANT
1	159759E	BASE	770.0x500.0x15.0	1
2	159760E	LATERAL DIREITA	755.0x500.0x15.0	1
3	159761E	LATERAL ESQUERDA	755.0x500.0x15.0	1
5	159762E	PRATELEIRA	770.0x500.0x15.0	1
6	159763E	TRAVESSA TAMPO	770.0x50.0x15.0	2
7	159764E	FUNDO	753.0x398.0x3.0	2
8	159765E	PORTA ESQUERDA	747.0x392.0x15.0	1
9	159766E	PORTA DIREITA	747.0x392.0x15.0	1
10	XXXXXX	PERFIL I 723X20X3,8MM	723.0x17.0x6.0	1
12	1609550	PÉ C/ SAPATA REGULÁVEL PLÁSTICA 0203420	xx	4
13	1609852	PUXADOR ESQUERDO MANHATTAN	300.3x15.0x20.0	1
14	1609851	PUXADOR DIREITO MANHATTAN	300.3x15.0x20.0	1
14	K072721	KIT 4 DOB 35MM ALTA - CALÇO FIXO - COM AMORT	xx	1
15	K072720	KIT PH3071 MÓD. BALCÃO 80CM 2 PORTAS	xx	1
E	-	TAPA FURO ADESIVO PAPEL 15mm	15.0x15.0x0.5	4
I	XXXXXX	TAPA FURO ADESIVO PAPEL 20MM	22.0x22.0x0.5	4

LISTA DE ACESSÓRIOS / FITTINGS LIST / LISTA DE ACCESORIOS

REF.	PEÇA	PART	PIEZA	QTDE	CÓDIGO
A	PARAFUSO MINIFIX	Cam Bolt 32xØ6mm	Perno de Leva 32xØ6mm	8	1602006
B	TAMBOR MINIFIX Ø14.9X11MM	Can Nut Ø15 mm	Porca de Leva Ø15 mm	8	1605358
C	PREGO 10 X 10 C/CABEÇA - Ø1,5 x 23mm	Nail 10 X 10 - Ø1,5 x 23mm	Clavo 10 X 10	32	1605365
D	CAVILHA DE MADEIRA 6X40	Dowel Ø6 x 40 mm	Tarugo Ø6 x 40 mm	12	1604742
F	PARAFUSO 4.5 X 35 CAB. CHATA PHILIPS	Screw Ø4.5 x 35 mm	Tornillo Ø4.5 x 35 mm	4	4,5x35
G	PARAFUSO 4 X 25 CAB. CHATA PHILIPS	Screw Ø4 x 25 mm	Tornillo Ø4 x 25 mm	8	1607862
H	PARAFUSO 4 X 40 CAB. CHATA PHILIPS	Screw Ø4 x 40 mm	Tornillo Ø4 x 40 mm	4	1604937

KIT DOBRADIÇAS / HINGES KIT / KIT BISAGRAS

REF.	PEÇA	PART	PIEZA	QTDE	CÓDIGO
J	PARAFUSO 4 X 14 CAB. CHATA REBAIXADA PHILIPS	Screw Ø4 x 14 mm	Tornillo Ø4 x 14 mm	24	1602420
K	DOB. ALTA AMORT 35MM (4115402991)	HIGH HATCHE 35MM	HATCHE ALTO 35MM	4	1768796

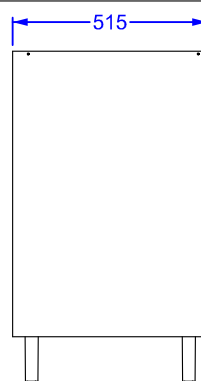
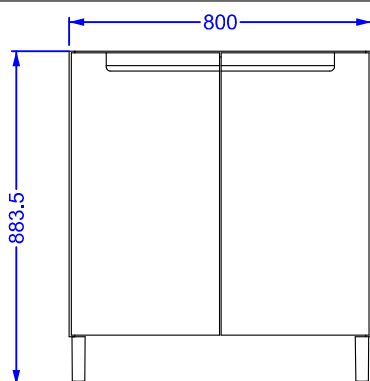

**PASSO 1
STEP 1
PASO 1**

PEÇAS NECESSÁRIAS
PARTS REQUIRED
PIEZAS NECESARIAS

INDICE	QUANT.
1	1
5	1
6	2

FERRAGEM NECESSÁRIA
HARDWARE REQUIRED
HERRAMIENTA NECESARIA

INDICE	IMAGEM	QTDE
D		12

FERRAMENTAS NECESSÁRIAS
TOOL REQUIRED
HERRAMIENTA NECESARIA

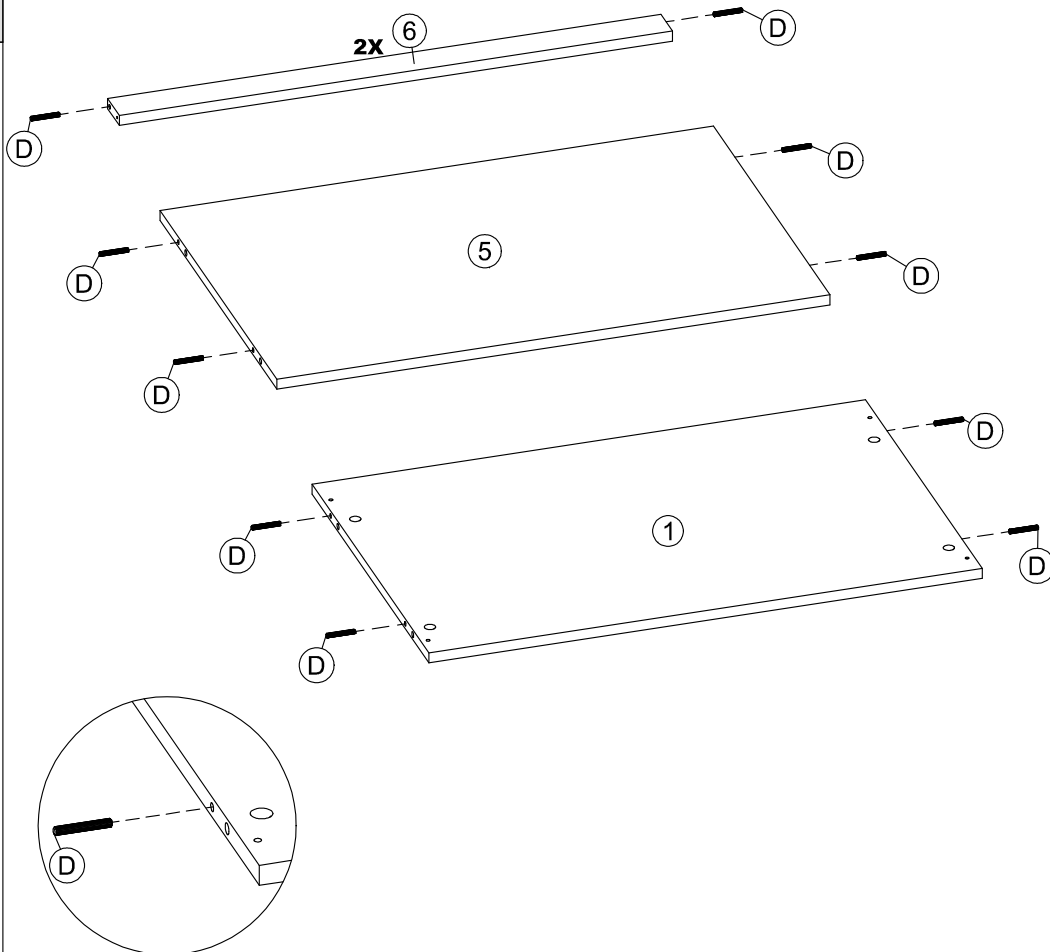
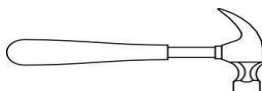

**PASSO 2
STEP 2
PASO 2**

PEÇAS NECESSÁRIAS
PARTS REQUIRED
PIEZAS NECESARIAS

INDICE	QUANT.
2	1
3	1

FERRAGEM NECESSÁRIA
HARDWARE REQUIRED
HERRAMIENTA NECESARIA

INDICE	QUANT.
A	8

FERRAMENTAS NECESSÁRIAS
TOOL REQUIRED
HERRAMIENTA NECESARIA

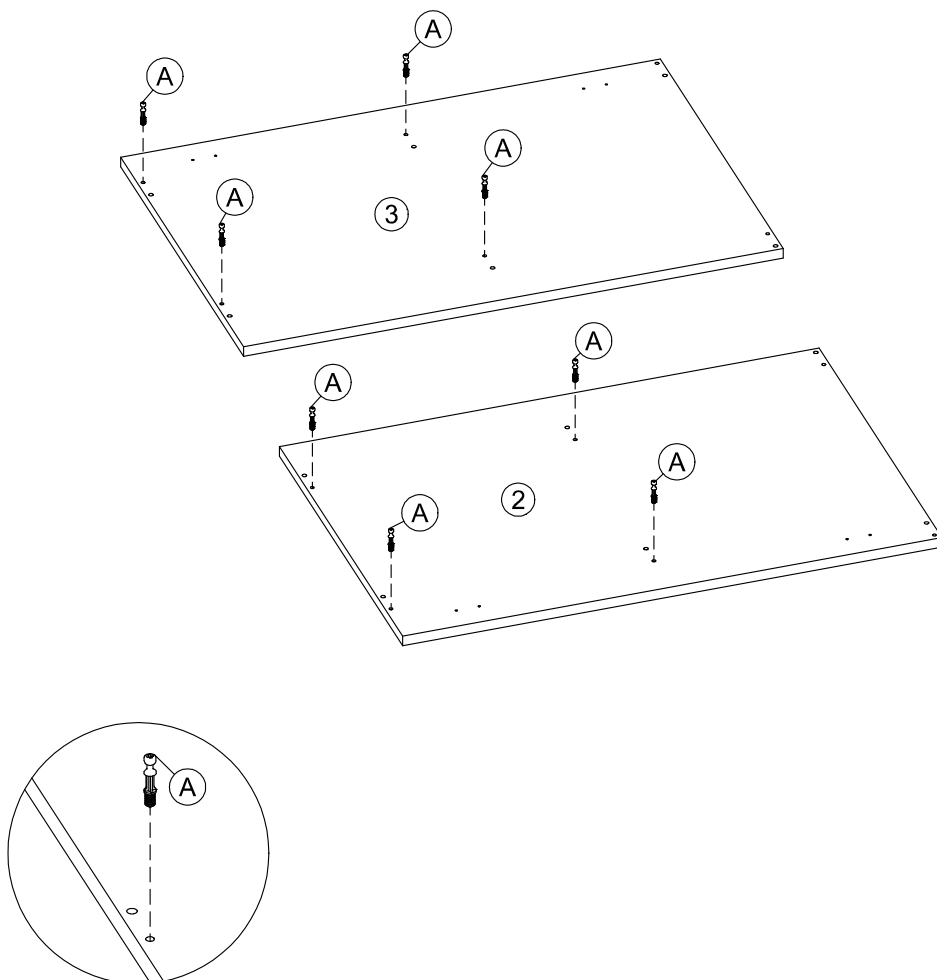
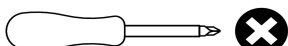



**PASSO 3
STEP 3
PASO 3**

PEÇAS NECESSÁRIAS
PARTS REQUIRED
PIEZAS NECESARIAS

INDICE	QUANT.
1	1
3	1
5	1
6	2

FERRAGEM NECESSÁRIA
HARDWARE REQUIRED
HERRAMIENTA NECESARIA

INDICE	IMAGEM	QTDE
B		4
E		2
H		2

FERRAMENTAS NECESSÁRIAS
TOOL REQUIRED
HERRAMIENTA NECESARIA

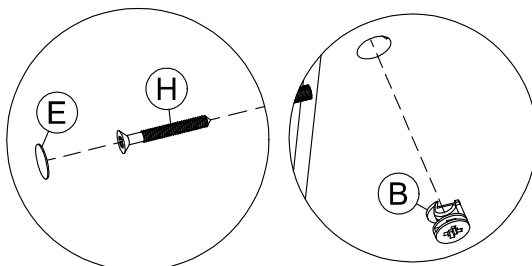
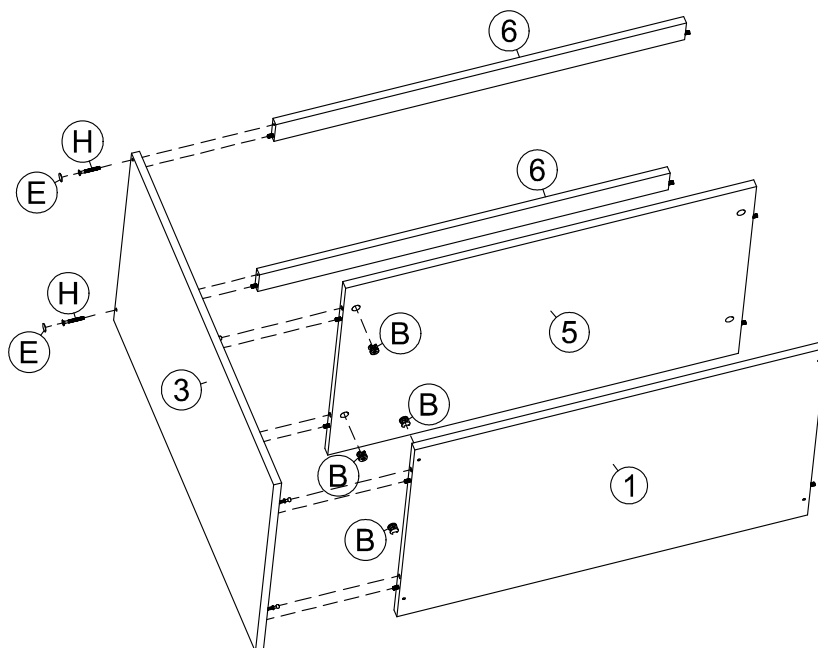
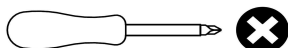



**PASSO 4
STEP 4
PASO 4**

PEÇAS NECESSÁRIAS
PARTS REQUIRED
PIEZAS NECESARIAS

INDICE	QUANT.
2	1

FERRAGEM NECESSÁRIA
HARDWARE REQUIRED
HERRAMIENTA NECESARIA

INDICE	IMAGEM	QTDE
B		4
E		2
H		2

FERRAMENTAS NECESSÁRIAS
TOOL REQUIRED
HERRAMIENTA NECESARIA

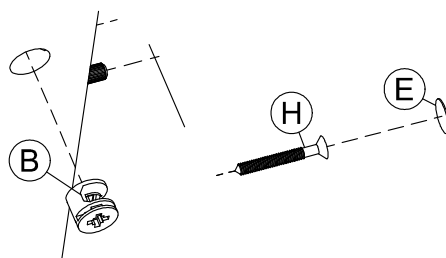
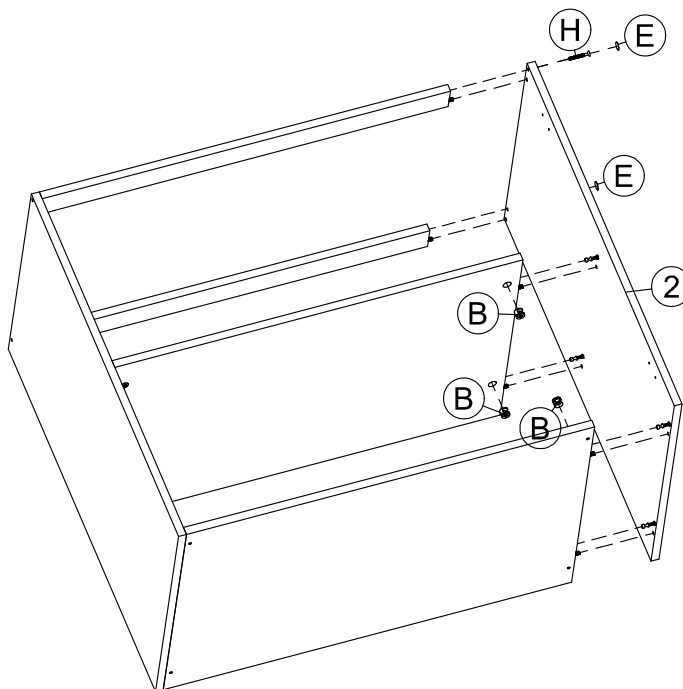
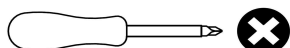

**PASSO 5
STEP 5
PASO 5**

PEÇAS NECESSÁRIAS
PARTS REQUIRED
PIEZAS NECESSARIAS

INDICE	QUANT.
12	4

FERRAGEM NECESSÁRIA
HARDWARE REQUIRED
HERRAMIENTA NECESSARIA

INDICE	IMAGEM	QTDE
F		4

FERRAMENTAS NECESSÁRIAS
TOOL REQUIRED
HERRAMIENTA NECESSARIA

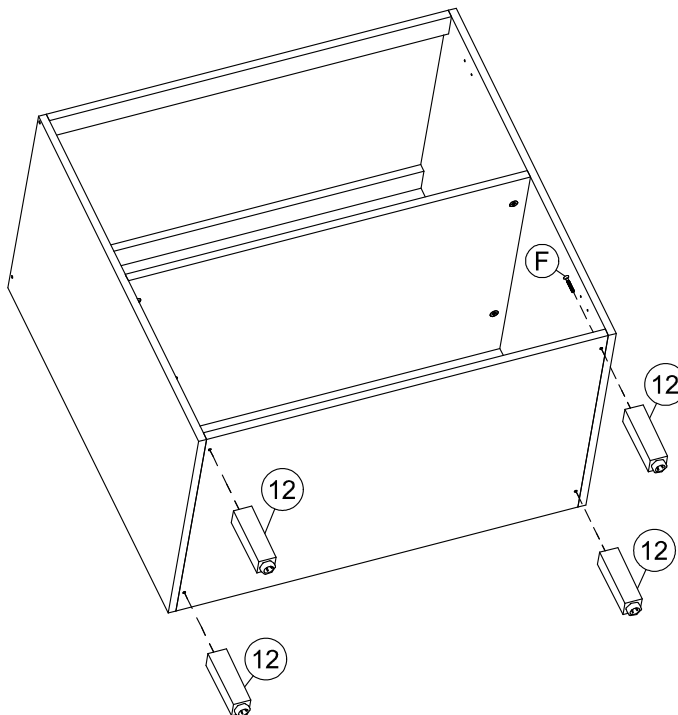
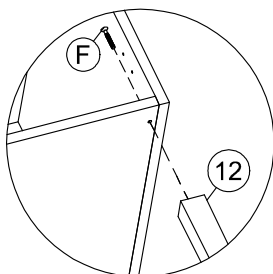
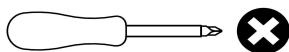

**PASSO 6
STEP 6
PASO 6**

PEÇAS NECESSÁRIAS
PARTS REQUIRED
PIEZAS NECESSARIAS

INDICE	QUANT.
7	2
10	1

FERRAGEM NECESSÁRIA
HARDWARE REQUIRED
HERRAMIENTA NECESSARIA

INDICE	IMAGEM	QTDE
C		32

FERRAMENTAS NECESSÁRIAS
TOOL REQUIRED
HERRAMIENTA NECESSARIA

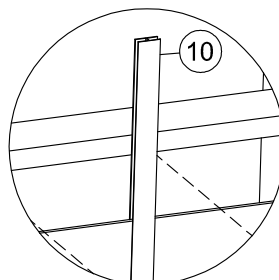
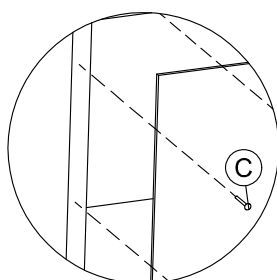
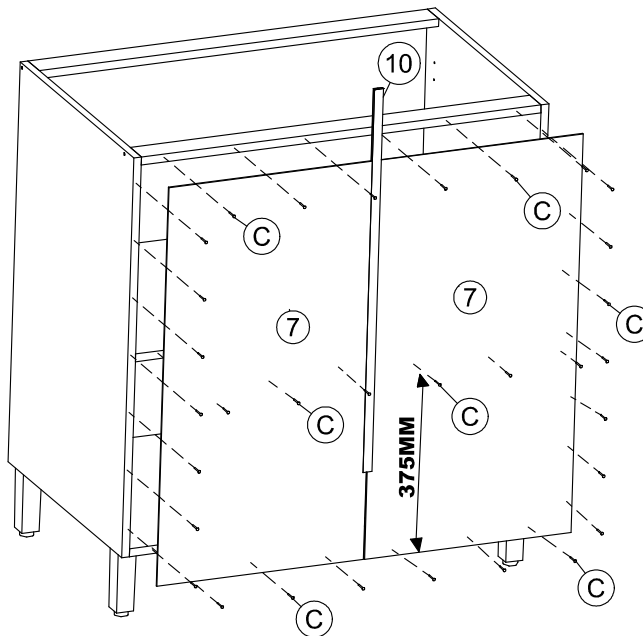
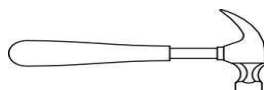



**PASSO 7
STEP 7
PASO 7**

PEÇAS NECESSÁRIAS
PARTS REQUIRED
PIEZAS NECESARIAS

INDICE	QUANT.
8	1
9	1

FERRAGEM NECESSÁRIA
HARDWARE REQUIRED
HERRAMIENTA NECESSARIA

INDICE	IMAGEM	QTDE
J		8
K		4

FERRAMENTAS NECESSÁRIAS
TOOL REQUIRED
HERRAMIENTA NECESSARIA

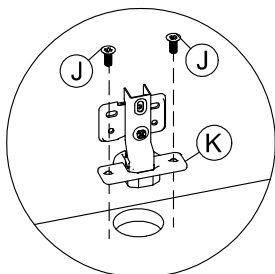
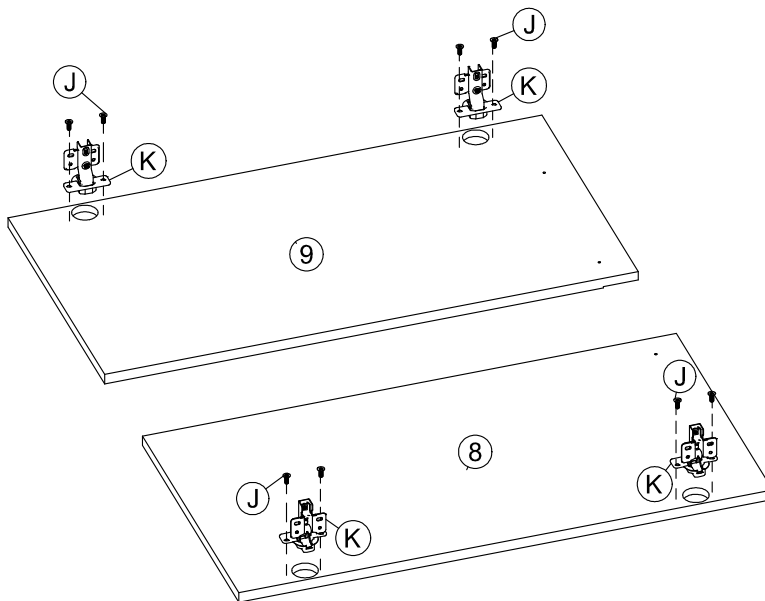
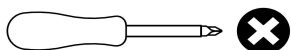





**PASSO 8
STEP 8
PASO 8**

PEÇAS NECESSÁRIAS
PARTS REQUIRED
PIEZAS NECESARIAS

INDICE	QUANT.
8	1
9	1
13	1
14	1

FERRAGEM NECESSÁRIA
HARDWARE REQUIRED
HERRAMIENTA NECESSARIA

INDICE	IMAGEM	QTDE
G		8
I		4
J		16
K		4

FERRAMENTAS NECESSÁRIAS
TOOL REQUIRED
HERRAMIENTA NECESSARIA

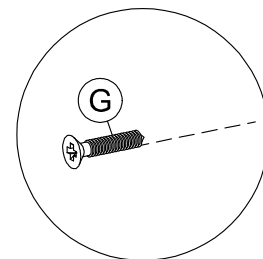
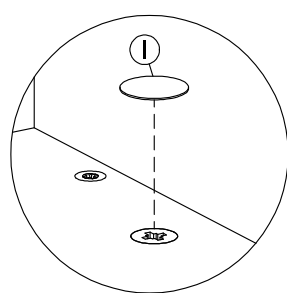
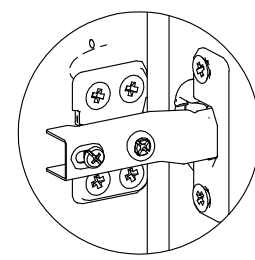
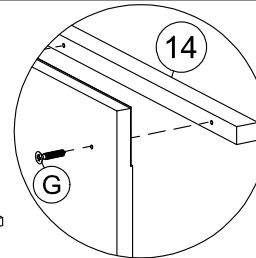
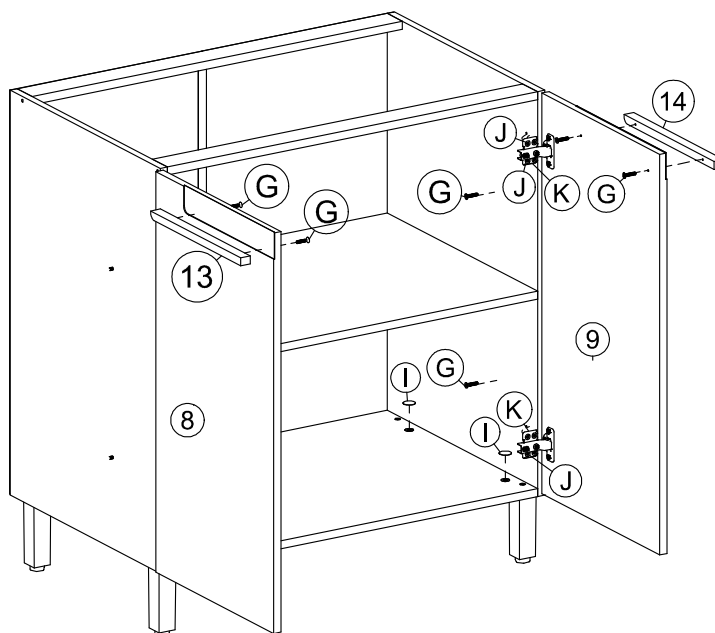
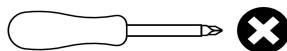

ESTE PARAFUSO É UTILIZADO PARA FIXAÇÃO ENTRE OS MÓDULOS
THIS SCREW IS USED FOR FIXING BETWEEN THE MODULES
ESTE TORNILLO SE UTILIZA PARA LA FIJACIÓN ENTRE LOS MÓDULOS