

HENN

Ind. e Com. de Móveis Henn
Mondai - SC - Brasil

+55 49 3674.3500

@moveishenn
www.henn.com.br

INSTRUÇÕES DE MONTAGEM

INSTRUCCIONES DE MONTAJE
ASSEMBLY INSTRUCTIONS

CADEIRA ESTHER

S39-537 Nature/Corano Caramelo
S39-538 Nature/Creme
S39-539 Nature/Cacao

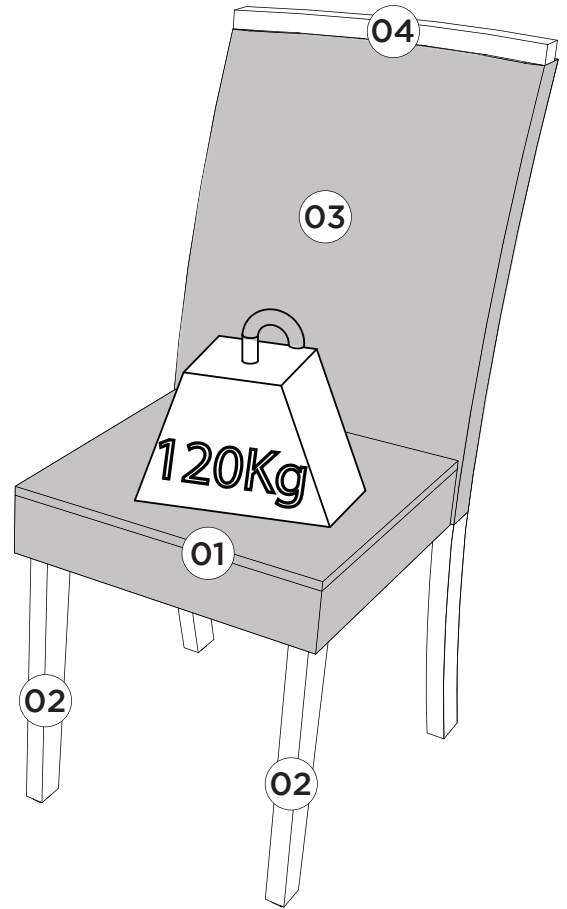
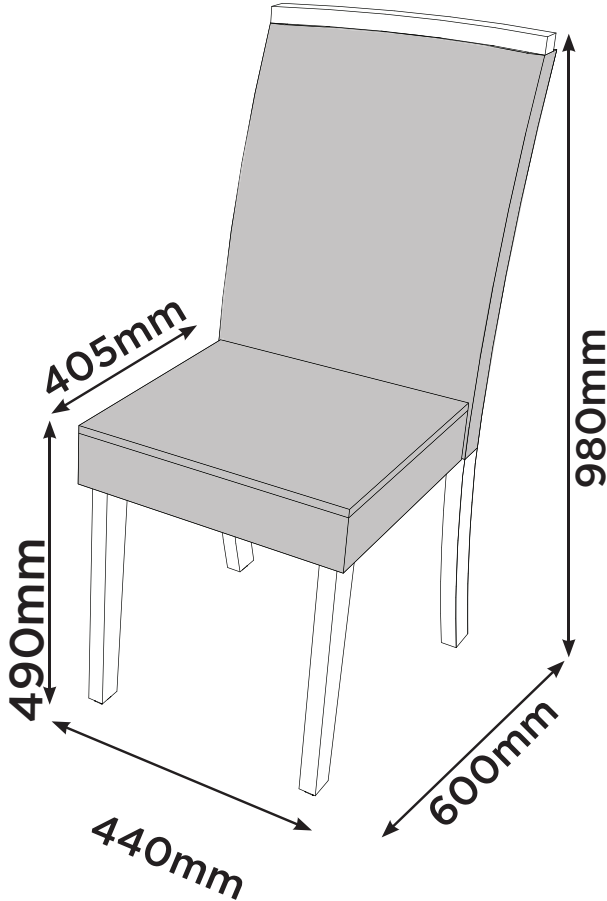

Pesos máximos recomendados
com carga distribuída
Peso máximo recomendado con
la carga distribuída
Recommended maximum
weights with evenly distributed.

Requisitos para montagem
Requisitor para la montaje
Assembly Requirements

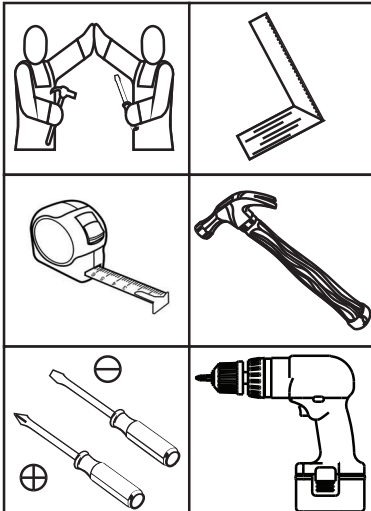

Imagens meramente ilustrativas
Imágenes meramente ilustrativas
Images for illustration only

AVISO

Para limpeza de seu móvel, use uma flanela seca ou umedecida, e não utilize produtos químicos que possam danificar seu produto.

SISTEMA DE MONTAGEM

O sistema de montagem dos produtos, funciona de acordo com a ordem crescente dos números indicados no desenho. Ex: 01, 02, 03, 04... até a conclusão da montagem.

ASSISTÊNCIA TÉCNICA

Para solicitação de Assistência Técnica você consumidor deverá entrar em contato com o Lojista o qual você realizou a compra deste produto e solicitar a assistência técnica das peças avariadas. A garantia abrange todas as peças, partes e componentes que eventualmente venham apresentar defeito de fabricação no prazo de 03 (três) meses, contando a partir da entrega do produto ao consumidor, mediante nota fiscal de compra. Se houver qualquer alteração na estrutura do produto ou ocorrer defeito por negligência do montador/consumidor em relação a instrução de montagem e manuseio, não será fornecido assistência técnica gratuita.

ADVERTENCIA

Para limpieza de su móvil, use una flanela seca o húmeda, y no utilice productos químicos que puedan dañar su producto.

SISTEMA DE MONTAJE

El sistema de montaje de los productos funciona de acuerdo con el orden creciente de los números indicados en el dibujo. Ej.: 01, 02, 03, 04... hasta la conclusión del montaje.

ASISTENCIA TÉCNICA

Para solicitar Asistencia Técnica, el consumidor debe comunicarse con el Comercio que usted realizó la compra de este producto y solicita asistencia técnica para las partes dañadas. La garantía cubre todas las partes, piezas y componentes que eventualmente puedan presentar defecto de fabricación en el plazo de 03 (tres) meses, contados a partir de la entrega del producto al consumidor, mediante factura de compra. Si se produce algún cambio en la estructura del producto o se produce un defecto por negligencia del montador/consumidor en relación con las instrucciones de montaje y manipulación, no se prestará asistencia técnica gratuita.

NOTICE

To clean your furniture, use a dry or wet cloth, and do not use chemicals that may damage your product.

ASSEMBLY SYSTEM

The products' assembly system works according to the increasing order of the indicated numbers. For example: 01, 02, 03, 04 ... to the end of the assembly.

TECHNICAL ASSISTANCE

To request Technical Assistance, the consumer must contact the retailer from whom you purchased this product and request technical assistance for the damaged parts. The warranty covers all parts, parts and components that may eventually present a manufacturing defect within a period of 03 (three) months, counting from the delivery of the product to the consumer, by means of a purchase invoice. If there is any change in the structure of the product or defect occurs due to negligence of the assembler/consumer in relation to the assembly and handling instruction, free technical assistance will not be provided.

1

2x

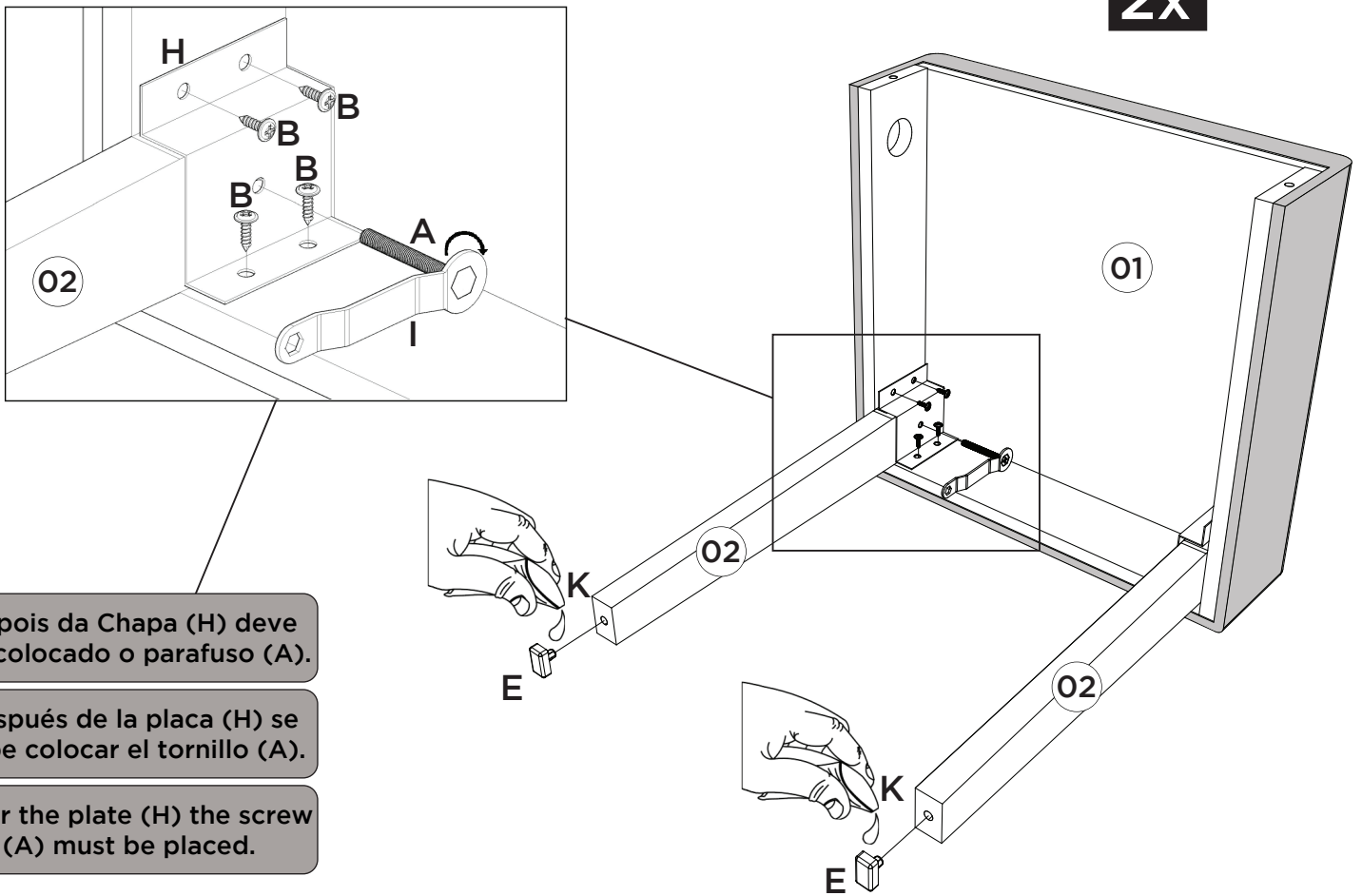

Depois da Chapa (H) deve ser colocado o parafuso (A).

Después de la placa (H) se debe colocar el tornillo (A).

After the plate (H) the screw (A) must be placed.

2

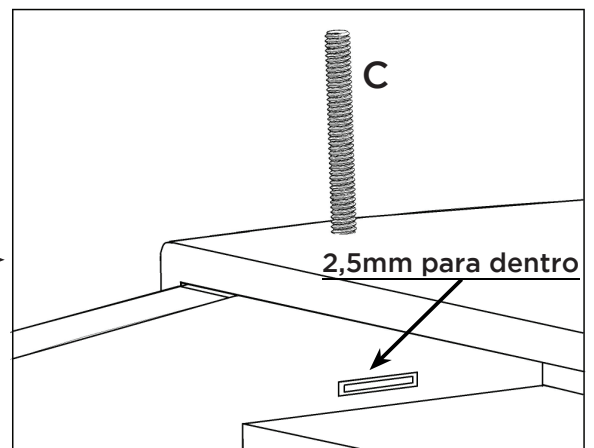
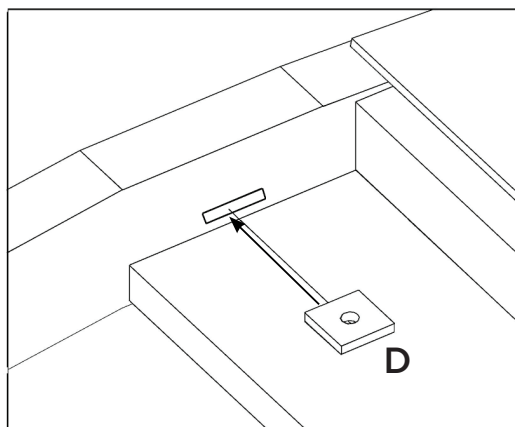

Deixar a Porca Metal (D) com a furação voltada para cima, pois esta, irá se encaixar com a Haste Roscada (C).

Deje la tuerca metal (D) con el orificio hacia arriba, ya que encajará con la varilla roscada (C).

Leave the Metal Nut (D) with the hole facing up as it will fit with the Threaded Rod (C).

2x

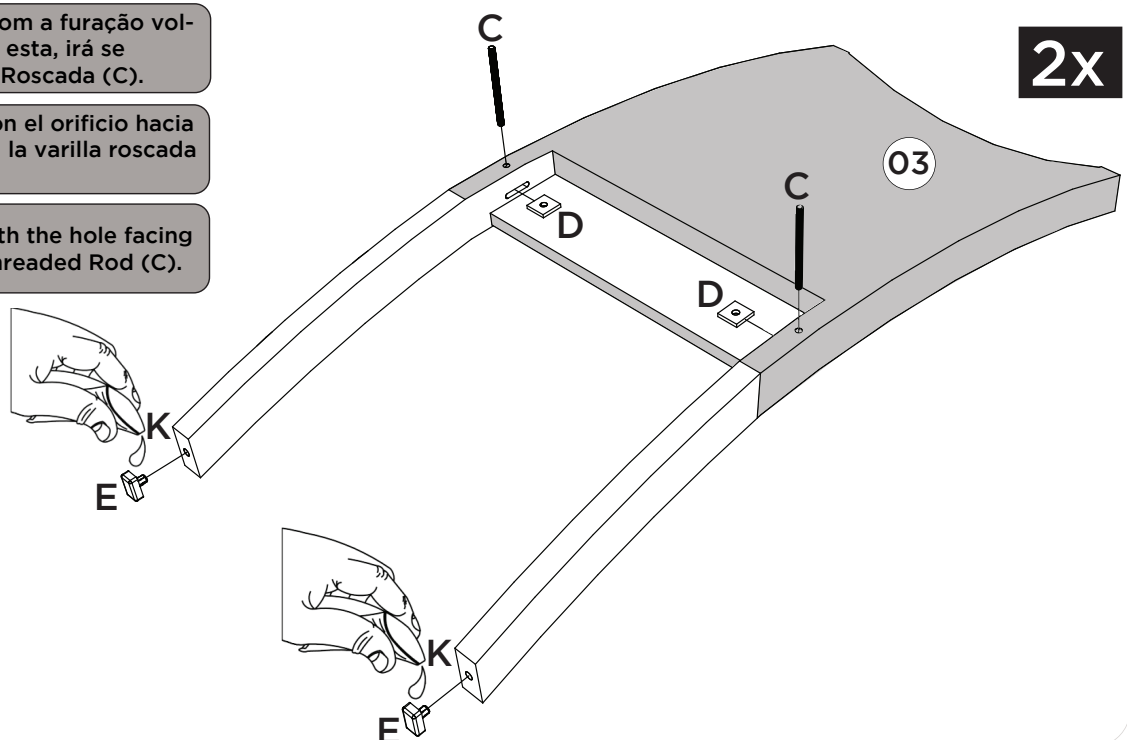

3 2x

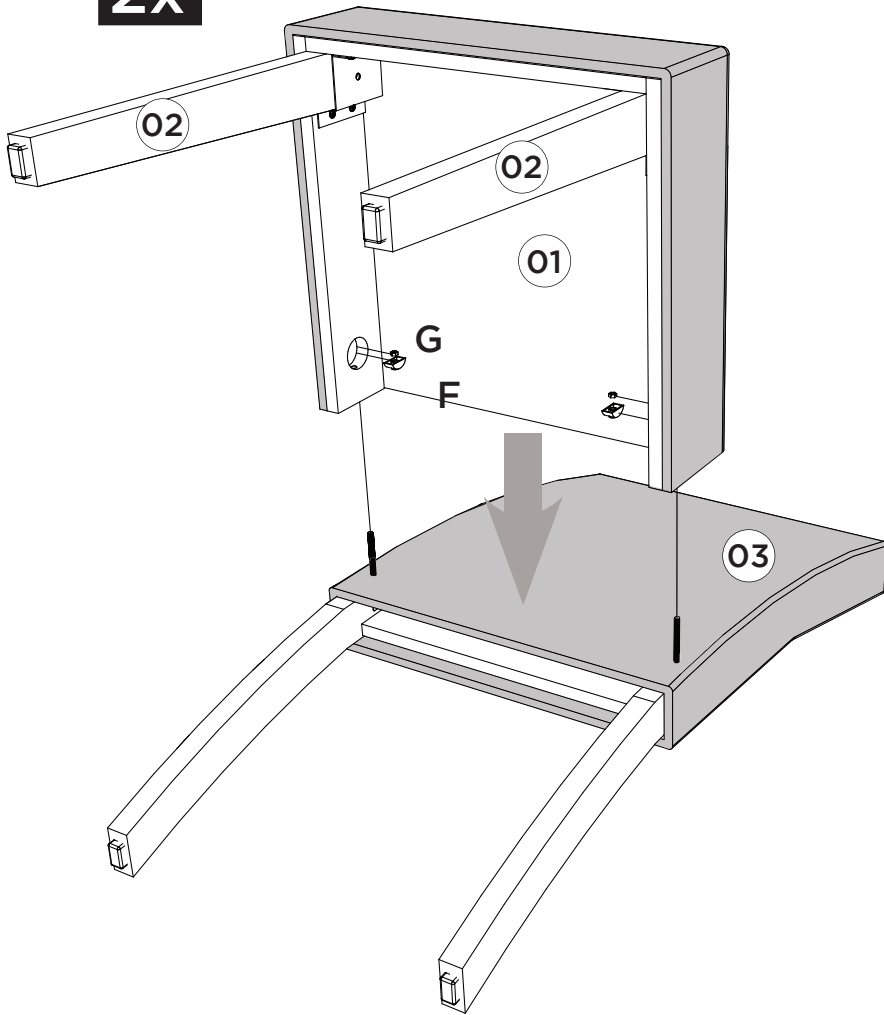

5

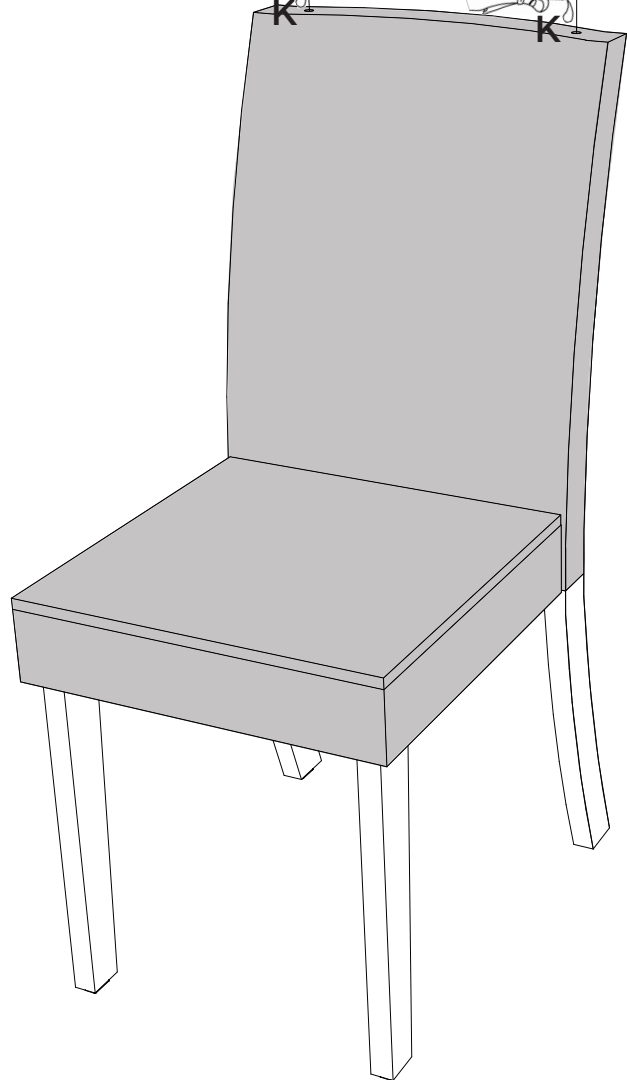
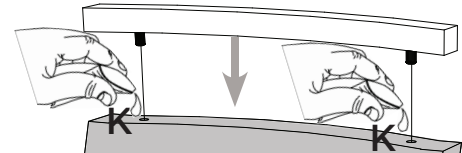
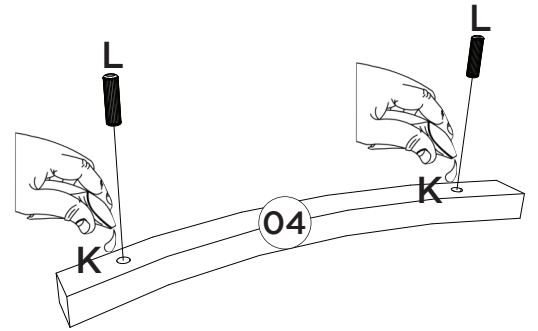

4





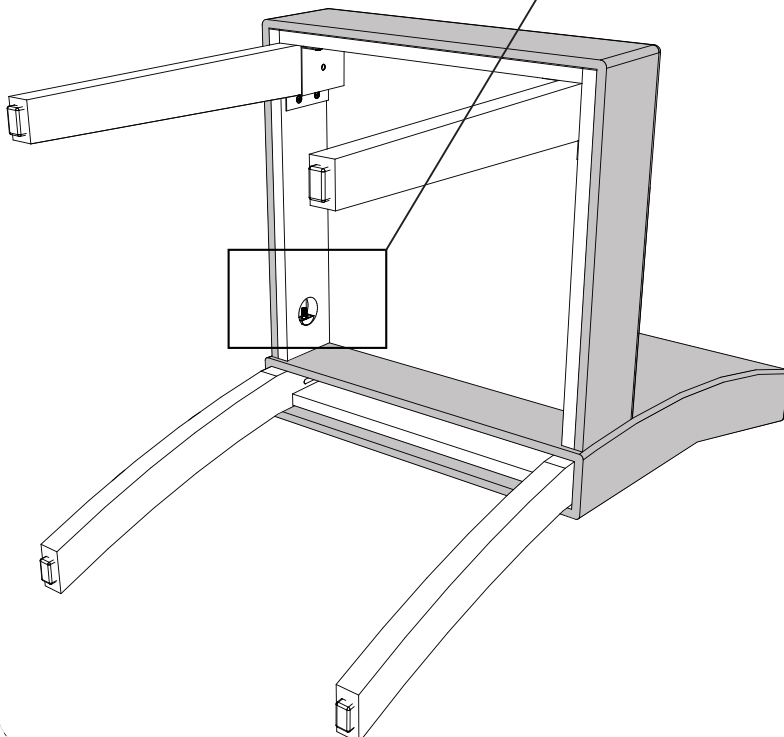
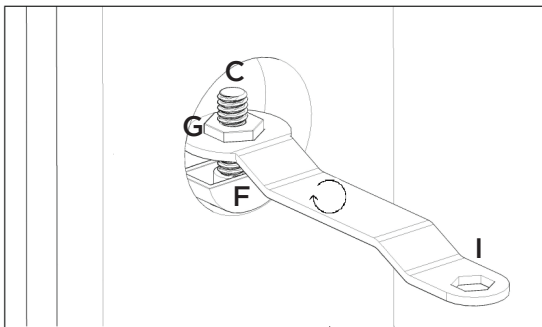





2x

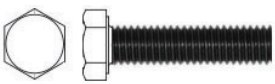

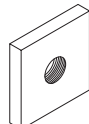
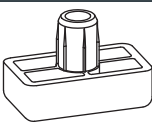
Item	Caixa Caja Box	Qty Ctd Qty	Descrição Descripción Description	Medidas (mm) Dimensions (mm) Size (measurements) (mm)
01	1/1	02	Assento Estofado Asiento tapizado Upholstered seat	430x410x130
02	1/1	04	Pé Frontal Pie delantero Front foot	450x55x25
03	1/1	02	Encosto Estofado Respaldo tapizado Upholstered backrest	982x440x185
04	1/1	02	Moldura Superior Marco superior Top Frame	420x74x25

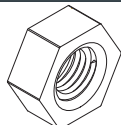
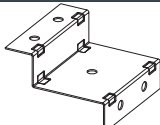
O volume contém peças para montagem de 2 Cadeiras.
 El volumen contiene piezas para montar 2 sillas.
 The volume contains parts for mounting 2 Chairs.

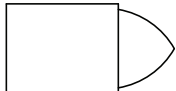
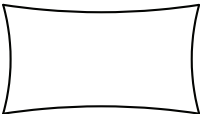
Ferragens | Herrajes | Hardware

<p>A  04x</p> <p>Parafuso 38mm com Rosca 1/4 Tornillo de 38 mm con rosca de 1/4 38mm Screw w / 1/4 Thread</p>	<p>B  16x</p> <p>Parafuso 3,5x14mm FLA. Tornillo 3,5x14mm FLA. Screw 3,5x14mm FLA.</p>	<p>C  04x</p> <p>Haste Roscada Varilla roscada Threaded rod</p>	<p>D  04x</p> <p>Porca Metal 23x23x3,2mm Rosca 1/4 Tuerca de metal 23x23x3,2mm 1/4 Rosca Porca Metal 23x23x3.2mm 1/4 thread</p>
<p>E  08x</p> <p>Sapata Deslizante 15x26x8mm Zapato deslizante 15x26x8mm Sliding Shoe 15x26x8mm</p>	<p>F  04x</p> <p>Arruela Meia Lua Media luna cerda Half moon nut</p>	<p>G  04x</p> <p>Porca Sextavada com Rosca 1/4 1/4 tuerca hexagonal roscada 1/4 Threaded Hex Nut</p>	<p>H  04x</p> <p>Chapa metal (ZC) 74x44mm La chapa metálica (CB) 74x44mm Sheet Metal (ZC) 74x44mm</p>
<p>I  01x</p> <p>Chave Sextavada Llave hexagonal Hex Wrench</p>	<p>J  01x</p> <p>Giz de correção Tiza de corrección Chalk of correction</p>	<p>K  01x</p> <p>Sachê de cola Bolsa de pegamento Glue bag</p>	<p>L  04x</p> <p>Cavilha Madeira 10x35mm Taco de madeira de 10x35 mm 10x35mm wooden dowel</p>

HENNInd. e Com. de Móveis Henn
Mondai - SC - Brasil

☎ +55 49 3674.3500

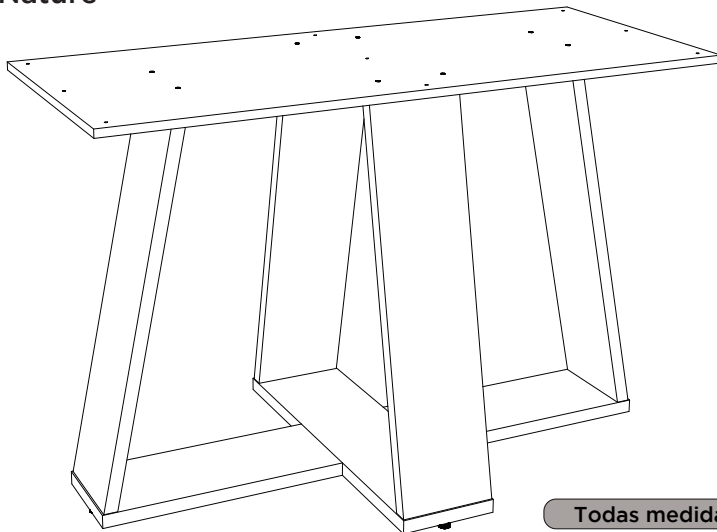
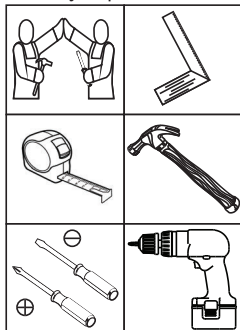
📧 @moveishenn
www.henn.com.br**INSTRUÇÕES DE
MONTAGEM**INSTRUCCIONES DE MONTAJE
ASSEMBLY INSTRUCTIONS**BASE MESA LINS | BASE MESA LINS | LINS TABLE BASE****S429-128 Nature****Todas medidas em mm.****Todas las medidas en mm.****All measurements in mm.****Requisitos para montagem
Requisitos para la montaje
Assembly Requirements**

Imagens meramente ilustrativas,
não acompanha o produto.
Imágenes ilustrativas, no incluidas
con el producto.

Illustrative images, not included
with the product.

AVISO

Para limpeza de seu móvel, use uma flanela seca ou umedecida, e não utilize produtos químicos que possam danificar seu produto.

SISTEMA DE MONTAGEM

O sistema de montagem dos produtos, funciona de acordo com a ordem crescente dos números indicados no desenho.
Ex: 01, 02, 03, 04... até a conclusão da montagem.

ASSISTÊNCIA TÉCNICA

Para solicitação de Assistência Técnica você consumidor deverá entrar em contato com o Lojista o qual você realizou a compra deste produto e solicitar a assistência técnica das peças avariadas. A garantia abrange todas as peças, partes e componentes que eventualmente venham apresentar defeito de fabricação no prazo de 03 (três) meses, contando a partir da entrega do produto ao consumidor, mediante nota fiscal de compra. Se houver qualquer alteração na estrutura do produto ou ocorrer defeito por negligência do montador/consumidor em relação a instrução de montagem e manuseio, não será fornecido assistência técnica gratuita.

ADVERTENCIA

Para limpieza de su móvil, use una flanela seca o húmeda, y no utilice productos químicos que puedan dañar su producto.

SISTEMA DE MONTAJE

El sistema de montaje de los productos funciona de acuerdo con el orden creciente de los números indicados en el dibujo. Ej.: 01, 02, 03, 04... hasta la conclusión del montaje.

ASISTENCIA TÉCNICA

Para solicitar Asistencia Técnica, el consumidor debe comunicarse con el Comercio que usted realizó la compra de este producto y solicita asistencia técnica para las partes dañadas. La garantía cubre todas las partes, piezas y componentes que eventualmente puedan presentar defecto de fabricación en el plazo de 03 (tres) meses, contados a partir de la entrega del producto al consumidor, mediante factura de compra. Si se produce algún cambio en la estructura del producto o se produce un defecto por negligencia del montador/consumidor en relación con las instrucciones de montaje y manipulación, no se prestará asistencia técnica gratuita.

NOTICE

To clean your furniture, use a dry or wet cloth, and do not use chemicals that may damage your product.

ASSEMBLY SYSTEM

The products' assembly system works according to the increasing order of the indicated numbers. For example: 01, 02, 03, 04 ... to the end of the assembly.

TECHNICAL ASSISTANCE

To request Technical Assistance, the consumer must contact the retailer from whom you purchased this product and request technical assistance for the damaged parts. The warranty covers all parts, parts and components that may eventually present a manufacturing defect within a period of 03 (three) months, counting from the delivery of the product to the consumer, by means of a purchase invoice. If there is any change in the structure of the product or defect occurs due to negligence of the assembler/consumer in relation to the assembly and handling instruction, free technical assistance will not be provided.

ACESSÓRIOS | ACCESORIOS | ACCESSORIES

A



x16

B



x19

C

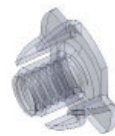

x4

D



x4

E

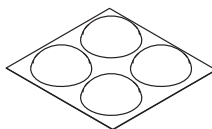

x12

F

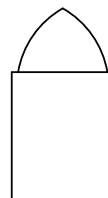

x1

LISTA DE PEÇAS | LISTA DE PIEZAS | LIST OF PIECES

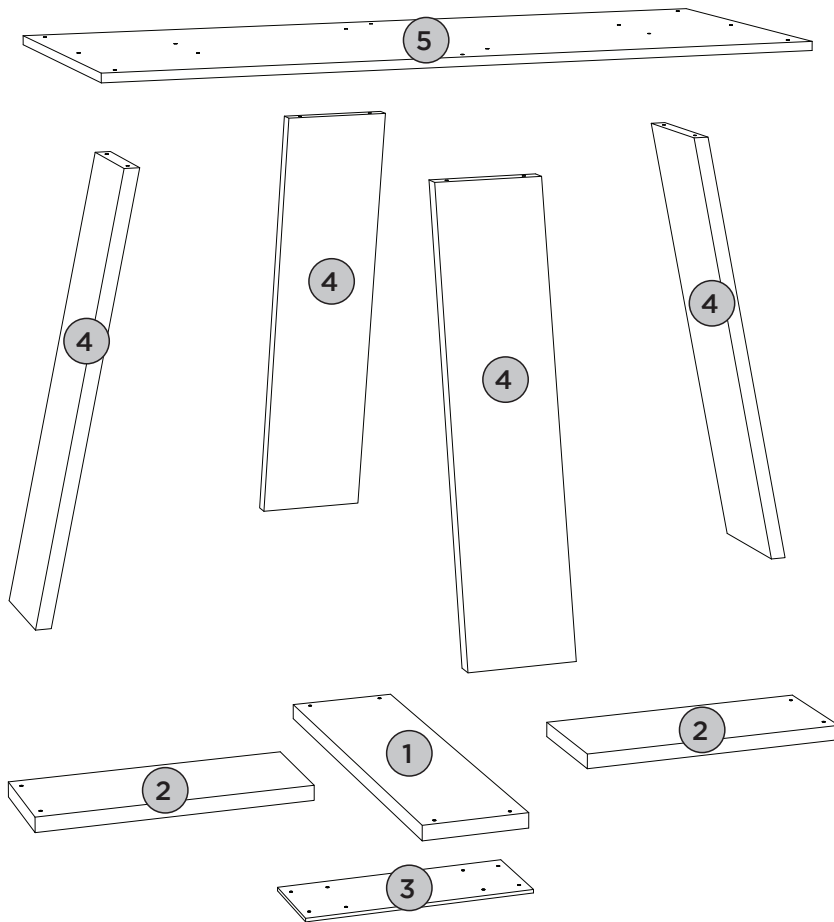

Item	Caixa Caja Box	Qtd Ctd Qty	Descrição Descripción Description	Dimensões (mm) Dimensiones (mm) Dimensions (mm)		
				Comprimento Largo Length	Largura Ancho Width	Espessura Grosor Thickness
1	1/1	01	BASE MAIOR BASE MÁS GRANDE BIGGER BASE	655	180	25
2	1/1	02	BASE MENOR BASE MÁS PEQUEÑA SMALLER BASE	465	180	25
3	1/1	01	FUNDO FONDO BOTTOM	400	150	6
4	1/1	04	PÉ PIE FOOT	746	178	25
5	1/1	01	TAMPO ESTRUTURAL PARTE SUPERIOR ESTRUCTURAL STRUCTURAL TOP	1200	500	15

PASSO 1

ITM/S429-

PEÇAS REQUERIDAS

1	BASE MAIOR	x1
2	BASE MENOR	x2

ACESSÓRIOS REQUERIDOS

C		04
D		04

FERRAMENTAS NECESSÁRIAS

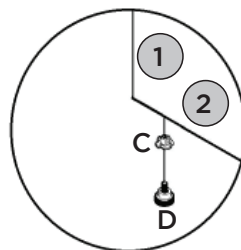
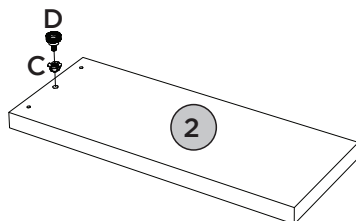
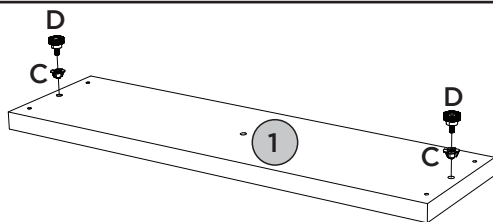

PASSO 2

PEÇAS REQUERIDAS

1	BASE MAIOR	x1
2	BASE MENOR	x2
3	FUNDO	x1

ACESSÓRIOS REQUERIDOS

B		10
---	---	----

FERRAMENTAS NECESSÁRIAS

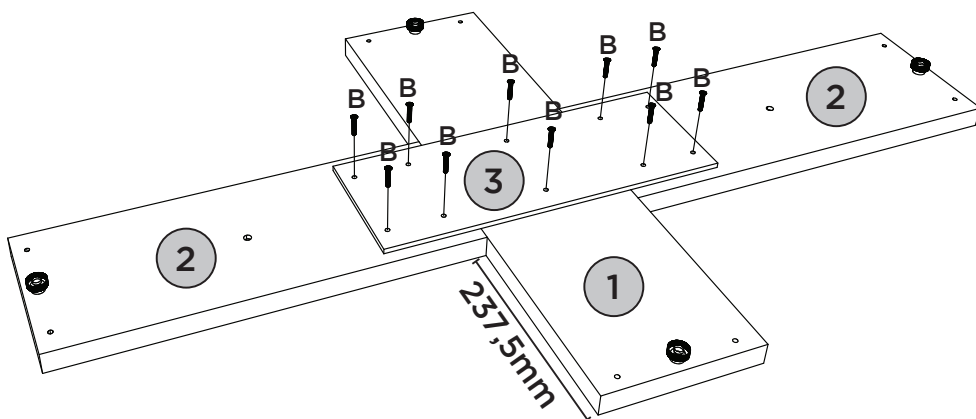
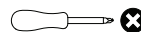

PEÇAS REQUERIDAS

4	PÉ	x4
---	----	----

ACESSÓRIOS REQUERIDOS

A			08
---	---	---	----

FERRAMENTAS NECESSÁRIAS

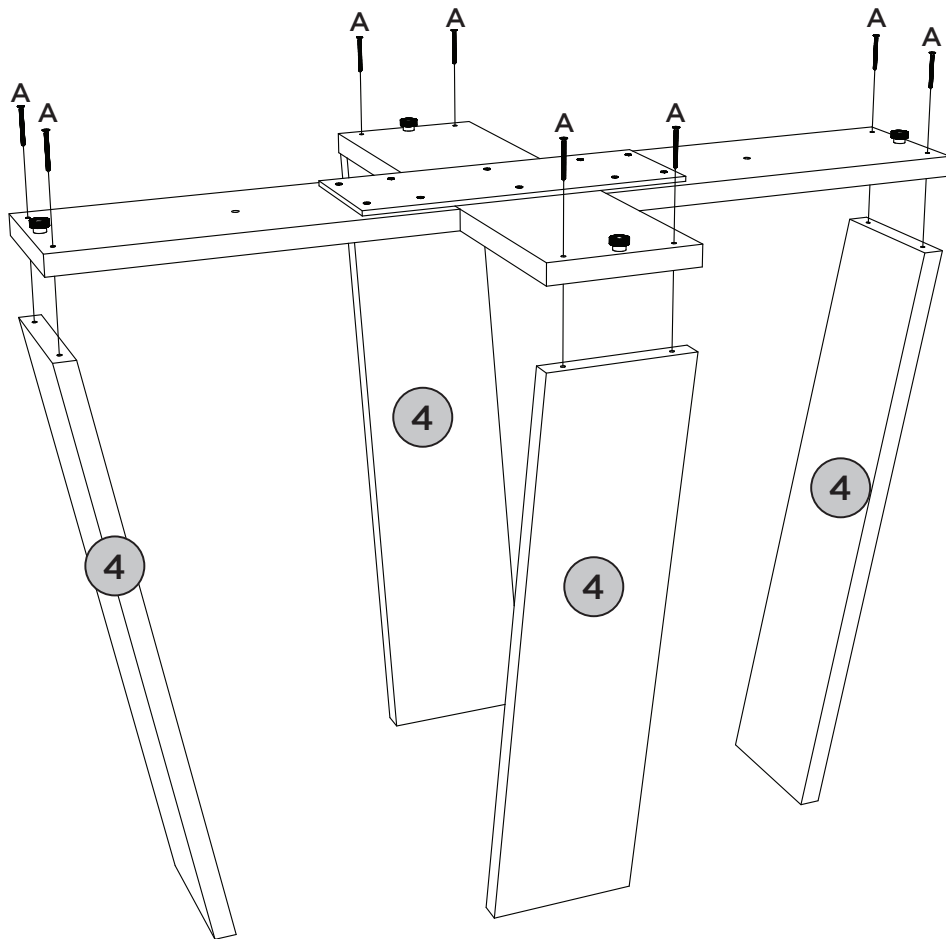
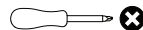

PASSO 4

ITM/S429-

PEÇAS REQUERIDAS

ACESSÓRIOS REQUERIDOS

FERRAMENTAS NECESSÁRIAS

5	TAMPO ESTRUTURAL	x1
---	------------------	----

A			08
---	---	---	----

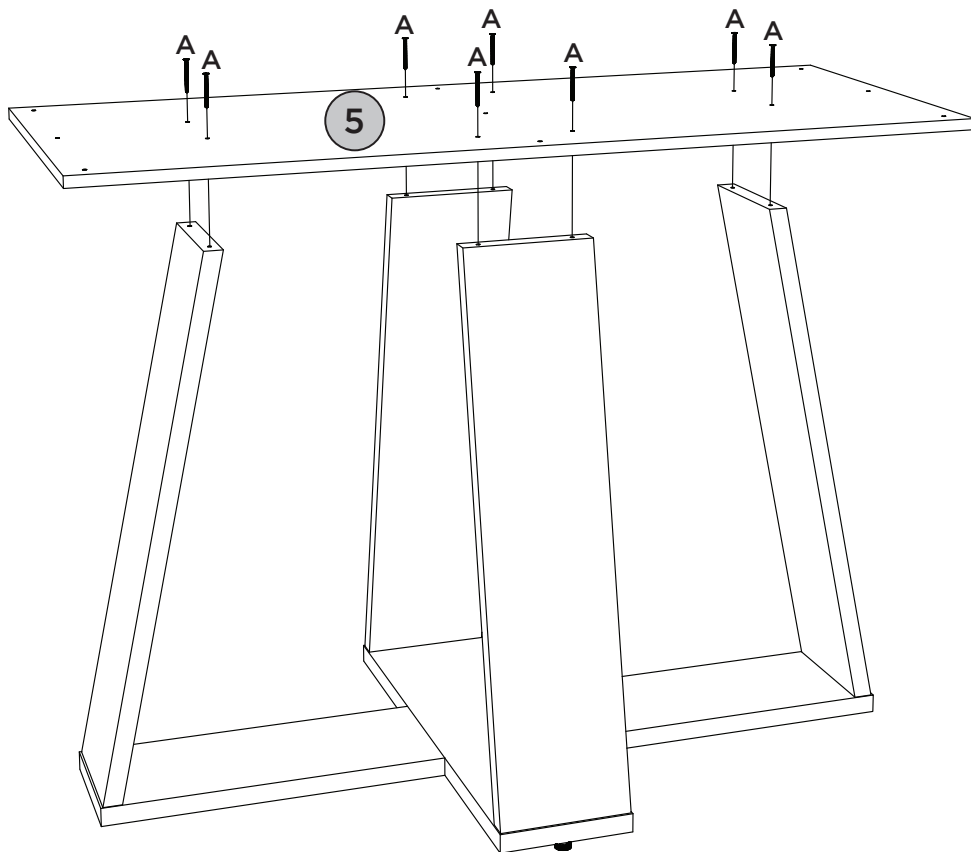
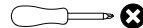

Opção de Montagem com o Tampo 2000x900
canto reto com Vidro (S906-139)

Opción de montaje con parte superior 2000x900
esquina recta con vidrio (S906-139)

Mounting Option with Top 2000x900
straight corner with Glass (S906-139)

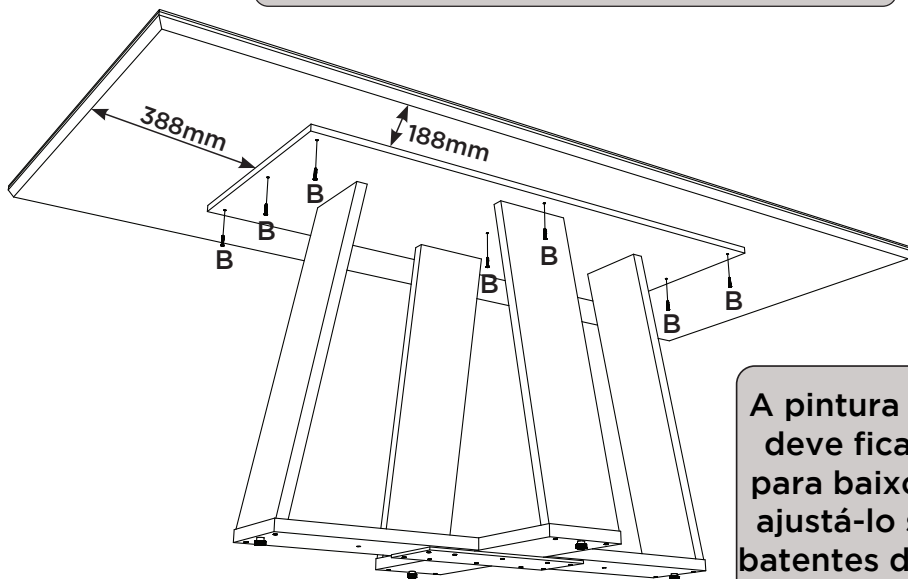

A pintura do Vidro
deve ficar virada
para baixo, depois
ajustá-lo sobre os
batentes de silicone
(E)

La pintura de vidrio
debe mirar
hacia abajo, luego
ajustarla sobre los
topes de silicona
(E)

The glass paint
should be facing
downwards, then
adjust it over the
silicone stops (E)

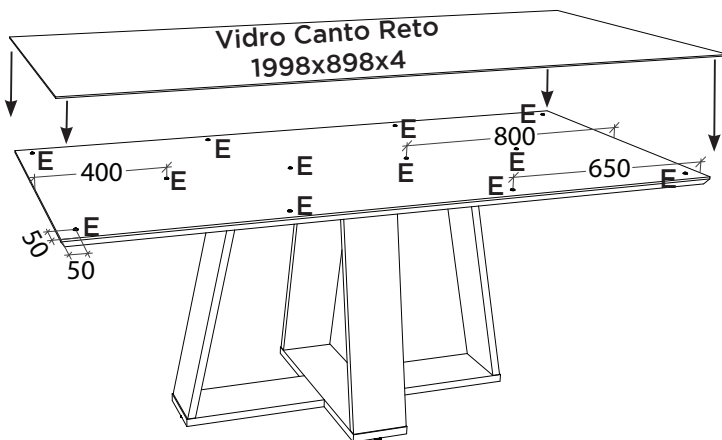

Produto Concluído (S429 + S906)
Producto Terminado (S429 + S906)
Finished Product (S429 + S906)

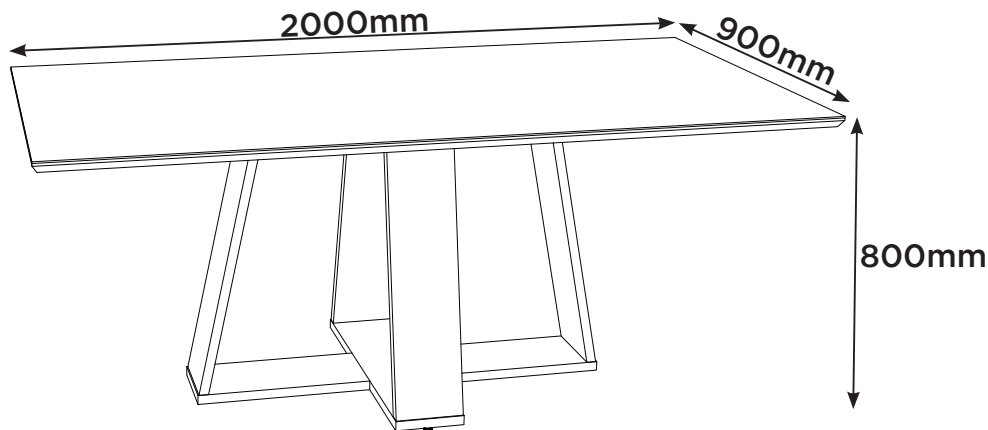

Opção de Montagem com o Tampo 2000x900
canto moeda com Vidro (S907-139)

Opción de montaje con parte superior 2000x900
Esquina de monedas con vidrio (S907-139)

Mounting Option with Top 2000x900
Coin corner with Glass (S907-139)

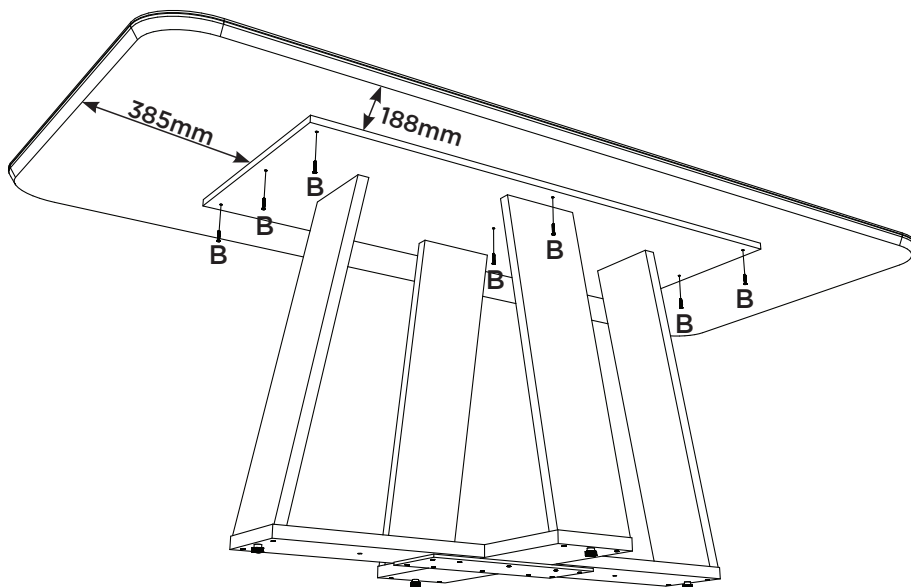

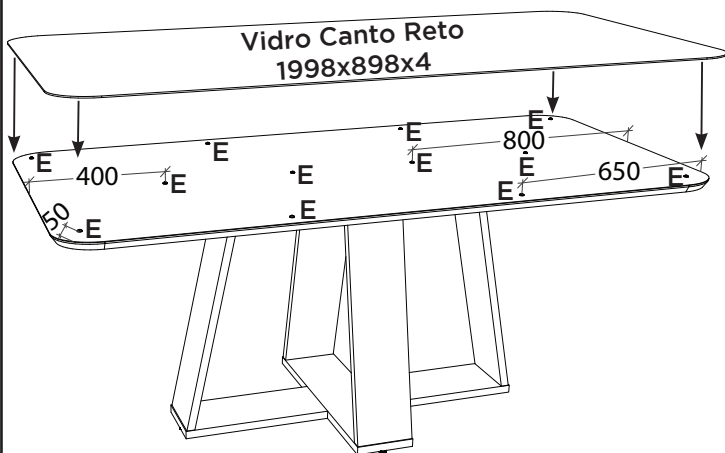

A pintura do Vidro deve ficar virada para baixo, depois ajustá-lo sobre os batentes de silicone (E)

La pintura de vidrio debe mirar hacia abajo, luego ajustarla sobre los topos de silicona (E)

The glass paint should be facing downwards, then adjust it over the silicone stops (E)

Produto Concluído (S429 + S907)
 Producto Terminado (S429 + S907)
 Finished Product (S429 + S907)

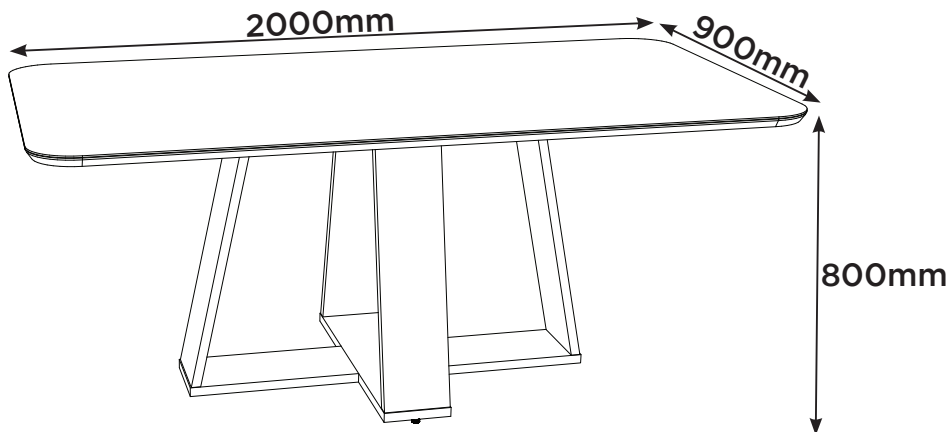

Opção de Montagem com o Tampo 1800x900
canto moeda com Vidro (S922-139)

Opción de montaje con parte superior 1800x900
Esquina de monedas con vidrio (S922-139)

Mounting Option with Top 1800x900
Coin corner with Glass (S922-139)

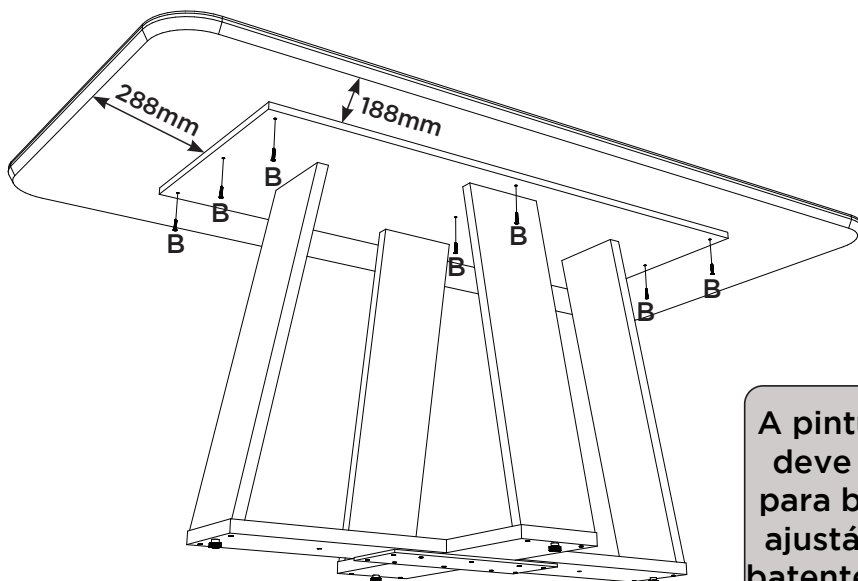

A pintura do Vidro
deve ficar virada
para baixo, depois
ajustá-lo sobre os
batentes de silicone
(E)

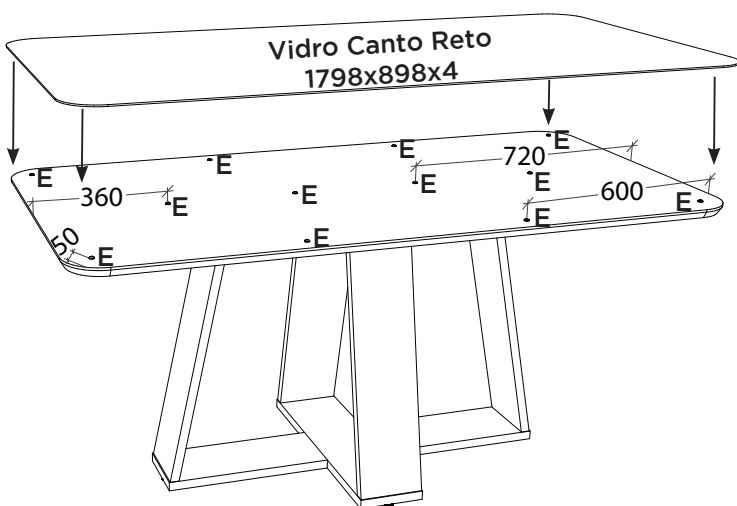

La pintura de vidrio
debe mirar
hacia abajo, luego
ajustarla sobre los
topes de silicona
(E)

The glass paint
should be facing
downwards, then
adjust it over the
silicone stops (E)

Producto Concluído (S429 + S922)
Producto Terminado (S429 + S922)
Finished Product (S429 + S922)

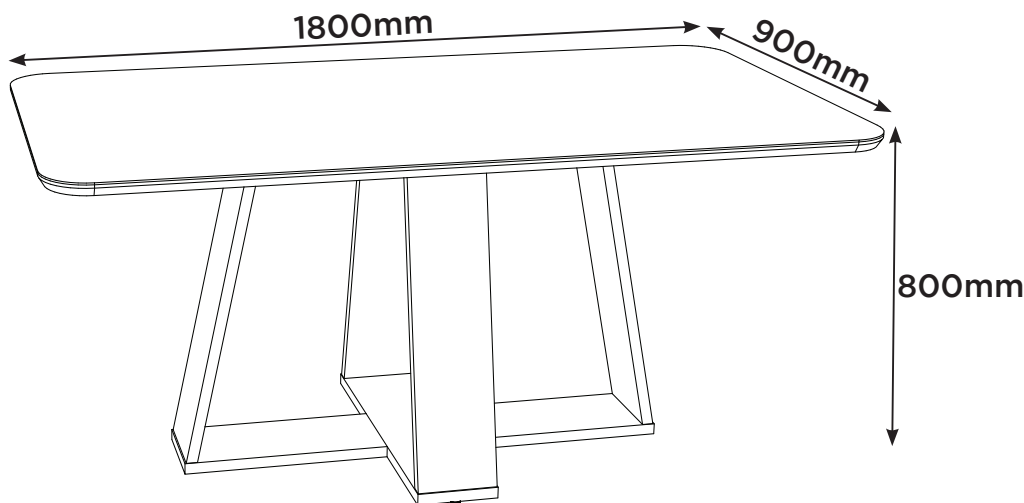

Pesos máximos recomendados con carga distribuída
Peso máximo recomendado con la carga distribuida
Recommended maximum weight with distributed load.

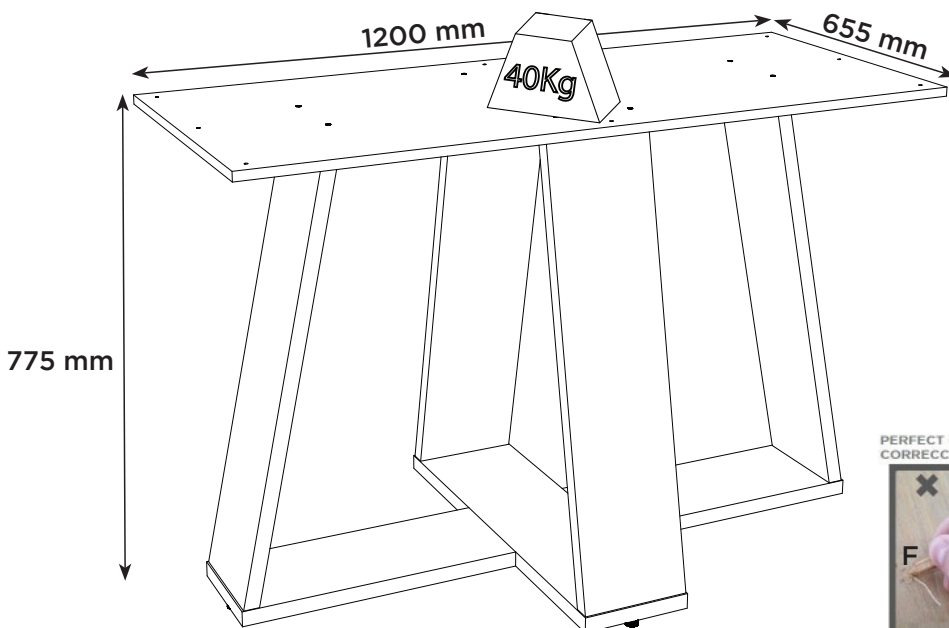

PERFECT CORRECTION
CORRECCIÓN PERFECTA

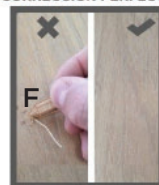

Produto Concluído
Producto terminado
Finished Product

