

**MANUAL DE MONTAGEM
ASSEMBLY INSTRUCTIONS
INSTRUCCIONES DE MONTAJE**

COD BR: BE 44 / BE 47

Sumário Summary Resumen

Introdução Introduction Introducción	3
Antes de começar Before starting Antes de comenzar	4
Evite acidentes Avoid accidents Evitar accidentes	4
Dimensões e ferramentas Dimensions and tools Dimensiones y herramientas	5
Identificação das peças Identifying parts Identificación de las piezas	6
Acessórios incluídos na caixa Hardware included in box Accesorios incluidos en la caja	7
Montagem do móvel Furniture assembly Montaje del mueble	8

Introdução Introduction Introducción

Leia atentamente este manual e siga os passos indicados para uma perfeita montagem.
Read this manual and follow the steps for the perfect fit.
Lea este manual y siga los pasos para el ajuste perfecto.

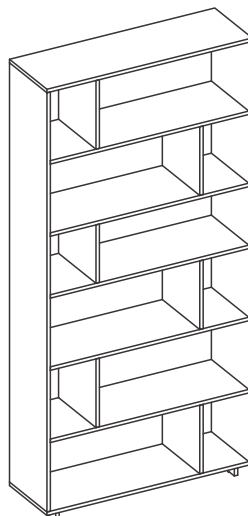

Antes de começar Before starting Antes de comenzar

Antes de começar a montagem prepare o ambiente, deixando-o completamente limpo e com bom espaço para iniciar o trabalho.

Prepare the room before starting the assembly, leaving it completely clean and the area in good condition to start the work.

Antes de comenzar el montaje preparar el ambiente, dejándolo completamente limpio y con bueno espacio para comenzar el trabajo.

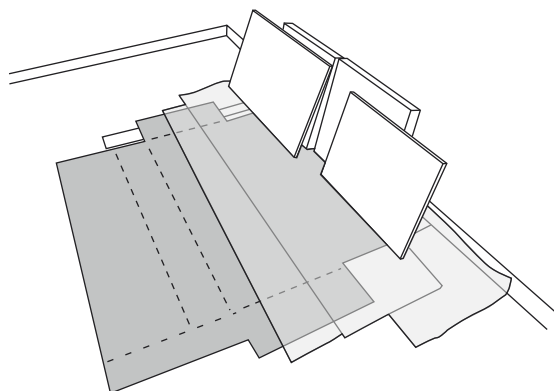

Utilize o papelão da própria embalagem para separar e apoiar as peças retiradas das caixas.

Use the cardboard of the packaging to separate and support the parts removed from the boxes.

Utilice el cartón de la embalaje para separar y apoyar las piezas desmontadas de las cajas.

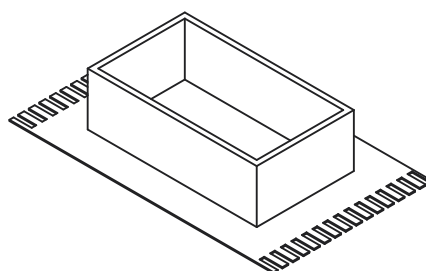

Forre a área de montagem com um cobertor ou tapete. Assim, você evita avarias nas peças durante o processo de montagem.

Cover the assembly area with a blanket or carpet to avoid damaging the parts during the assembly process.

Cubrir la zona de ensamble con una manta o alfombra. De este modo, se evitan daños en las piezas durante el proceso de montaje.



Evite acidentes Avoid accidents Prevenir accidentes

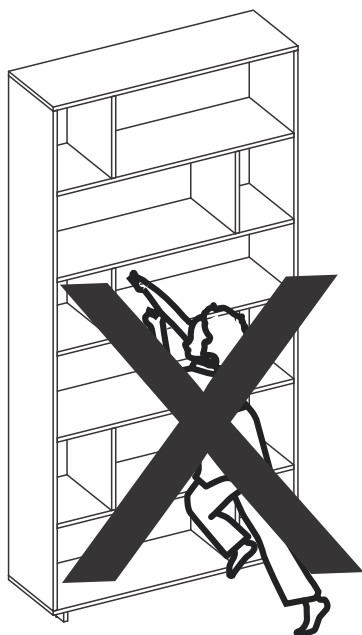

Não escale ou se apoie no móvel.

Do not climb or lean on the furniture.

No se suba ni se apoye en el mueble.

Dimensões e ferramentas
Dimensions and tools
Dimensiones y herramientas

BE 44

Dimensões:

L: 900 A:1875 P: 294 mm

Dimensions:

W: 35.43 H: 73.62 D: 11.69 inches

Dimensiones:

L: 900 A: 1875 P: 294 mm

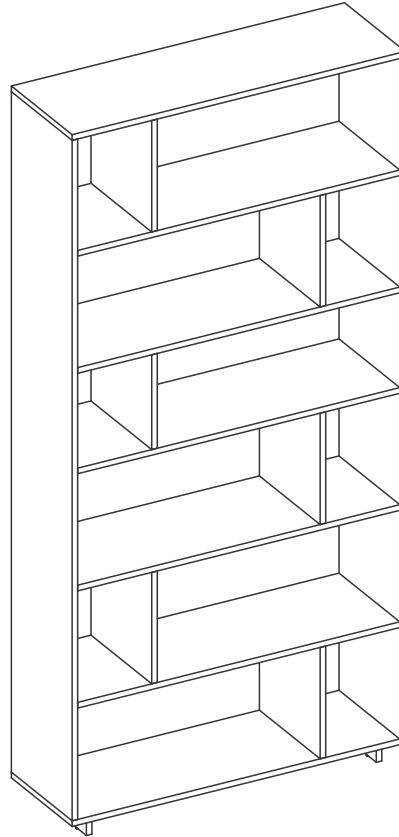

BE 47

Dimensões:

L: 1200 A:1875 P: 294 mm

Dimensions:

W: 47.24 H: 73.62 D: 11.69 inches

Dimensiones:

L: 1200 A: 1875 P: 294 mm

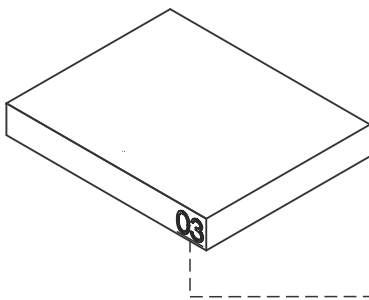

UTILIZE ALCOOL PARA REMOVER O NUMERO DAS PEÇAS
USE ALCOHOL TO REMOVE PART NUMBERS
UTILICE ALCOHOL PARA ELIMINAR EL NUMERO DE LAS PIEZAS

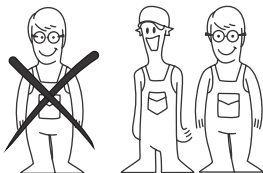

Para facilitar a montagem, utilize uma parafusadeira elétrica.
To improve assembly, use an electronic screwdriver.
Para facilitar el armado, utilice un destornillador eléctrico.

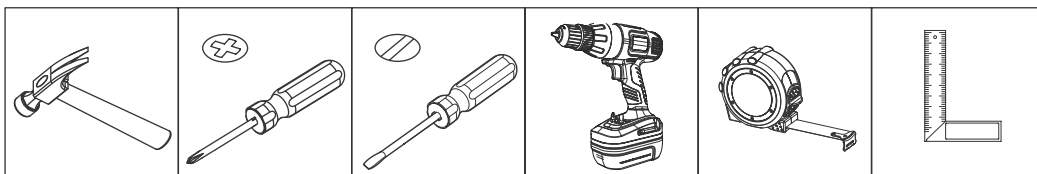

COD BR: BE 44 / BE 47

PEÇA	DESCRIÇÃO	QUANT.
001	LATERAL	2
002	BASE	1
003	TAMPO	1
004	PRATELEIRA	5
005	DIVISÓRIA MAIOR	5
006	DIVISÓRIA MENOR	1
007	COSTA	4
008	PÉS	4

PART	DESCRIPTION	QTY
001	SIDE	2
002	BASE	1
003	TOP	1
004	SHELF	5
005	LONGER DIVISION	5
006	LOWER DIVISION	1
007	BACK	4
008	FEET	4

PIEZA	DESCRIPCIÓN	CANTIDAD
001	LATERAL	2
002	BASE	1
003	TAPA	1
004	ESTANTE	5
005	DIVISORIO MAYOR	5
006	DIVISORIO MENOR	1
007	REVÉS	4
008	PIES	4

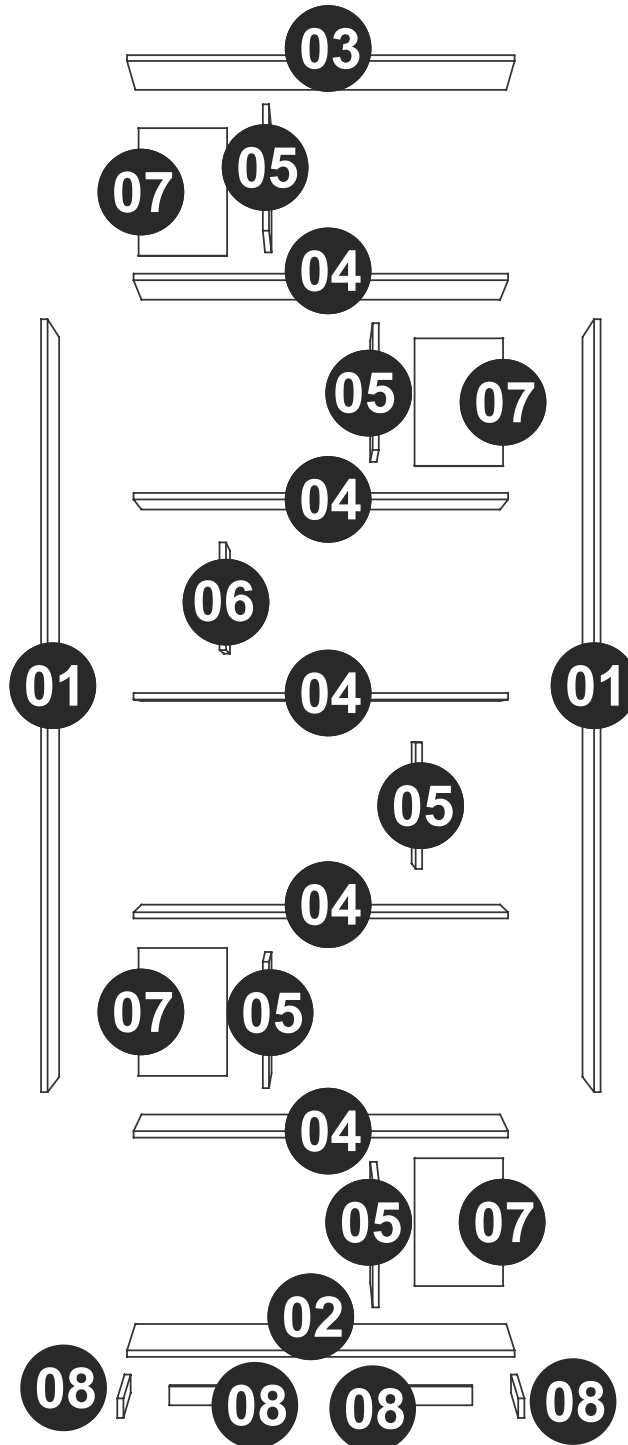



PÉS REDONDOS x 8
 ROUND FEET x 8
 PIES REDONDOS x 8

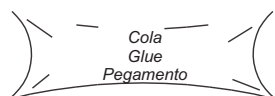

EF 000008x 2



EF 000106 x 4
 3,5 X 14 CC



EF 000033 x 60
 8x30

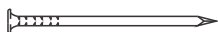

EF 000168 X 100
 10 X 10 C/C



EF 000132 x 26
 4 X 50 CC

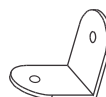

EF 000265 X 2



GIZ x 01
 CHALK x 01
 TIZA x 01

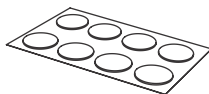

TAPA FUROS x 26
 STICKER x 26
 TAPAS PLÁSTICAS x 26

Utilize para medir as ferragens.

Utilice para medir el herraje.

Use for measuring the hardware.

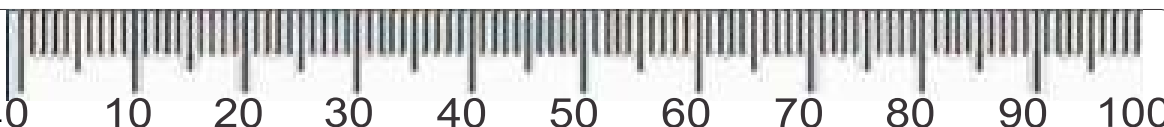

Garantia (exclusivo para o Brasil/exclusivo de Brasil/exclusive to Brazil):

A garantia dos produtos fabricados pela BRV Móveis, abrange eventuais defeitos-vícios de fabricação, no prazo estabelecido pelo código de Defesa do Consumidor, em seu artigo 26.II. o qual prevê a garantia de 90 (noventa) dias.

A = 2KG - 4.41LB

B = 6KG - 13.2LB

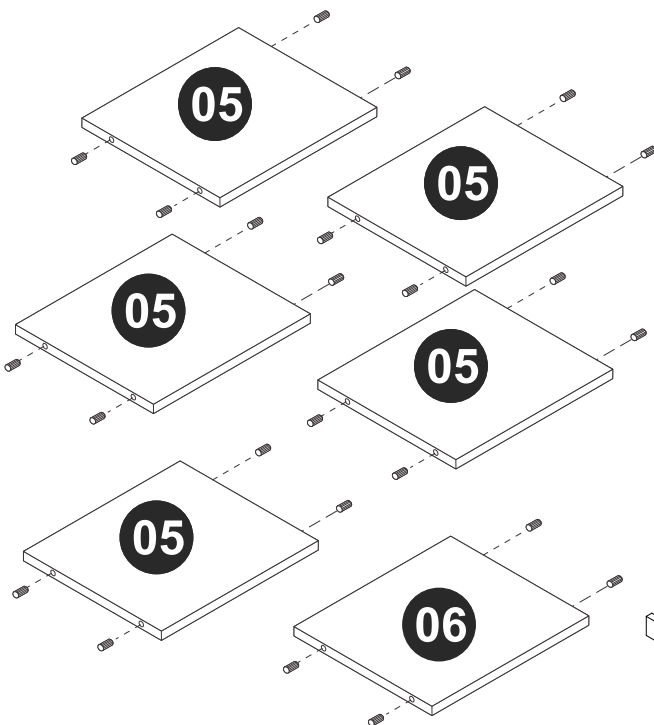
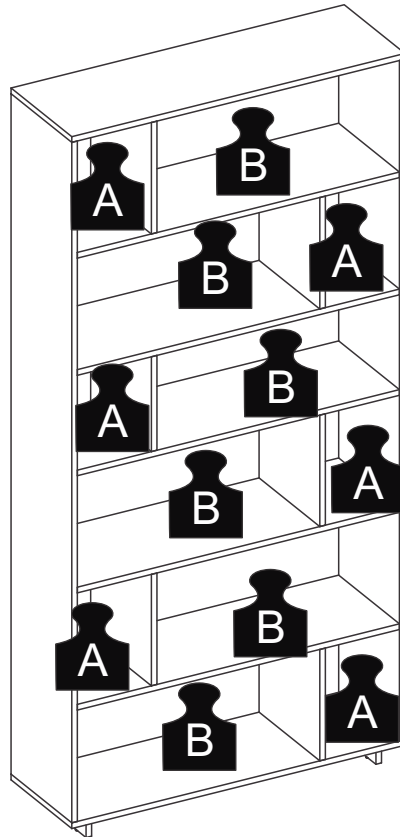

PASSO 1 / STEP 1 / PASO 1

Utilize a cola (EF 000008) antes de inserir a ferragem EF 000033 nas peças 05, 06 e 08.

Use the glue (EF 000008) before connecting hardware EF 000033 into pieces 05, 06 and 08.

Utilice el pegamento (EF 000008) antes de añadir el herraje EF 000033 en las piezas 05, 06 y 08.

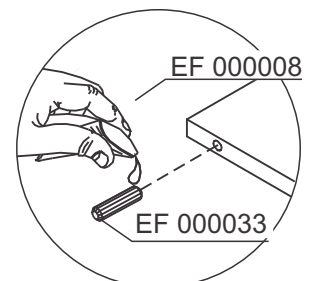
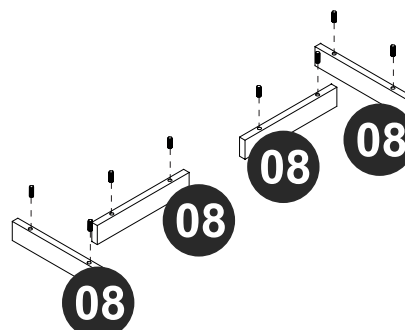

PASSO 2 / STEP 2 / PASO 2

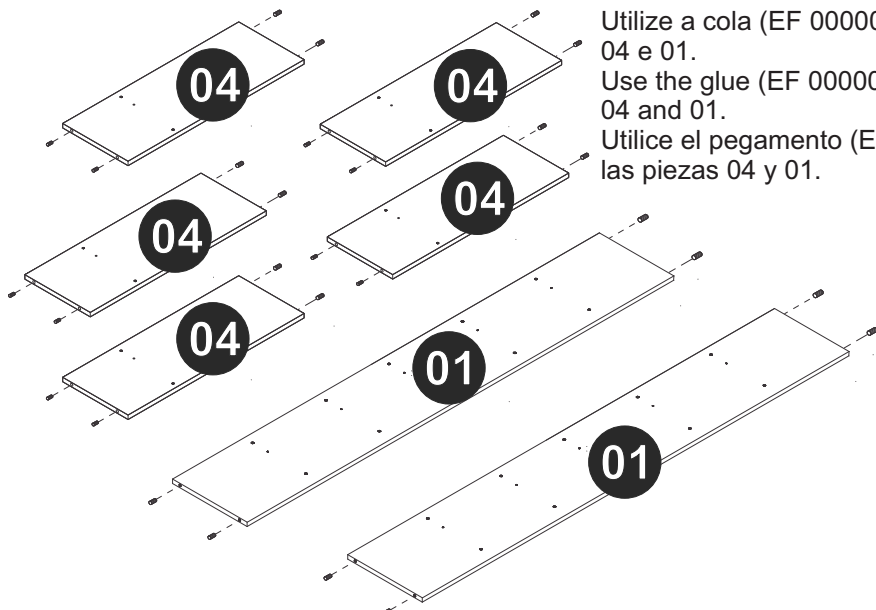

Utilize a cola (EF 000008) antes de inserir a ferragem EF 000033 nas peças 04 e 01.
Use the glue (EF 000008) before connecting hardware EF 000033 into pieces 04 and 01.
Utilice el pegamento (EF 000008) antes de añadir el herraje EF 000033 en las piezas 04 y 01.

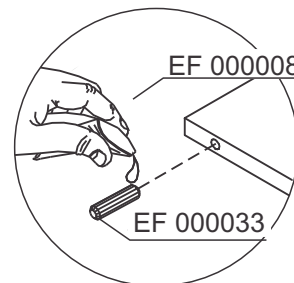

PASSO 3 / STEP 3 / PASO 3

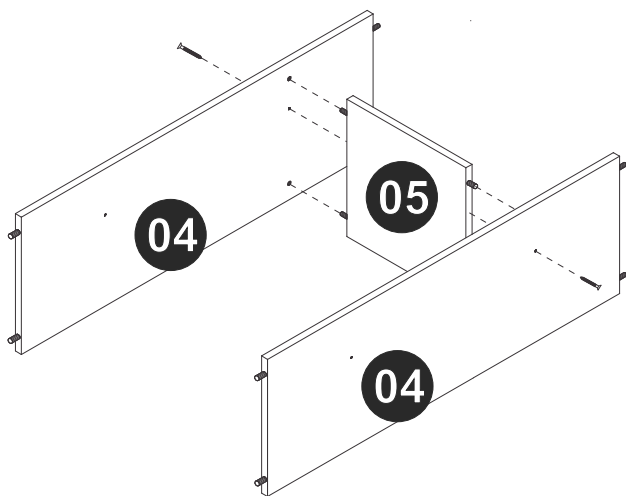

Conecte as peças 04 e 05 utilizando a ferragem EF 000132.
Connect pieces 04 and 05 using hardware EF 000132.
Junte las piezas 04 y 05 utilizando el herraje EF 000132.

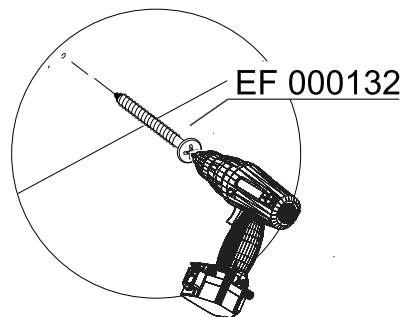

PASSO 4 / STEP 4 / PASO 4

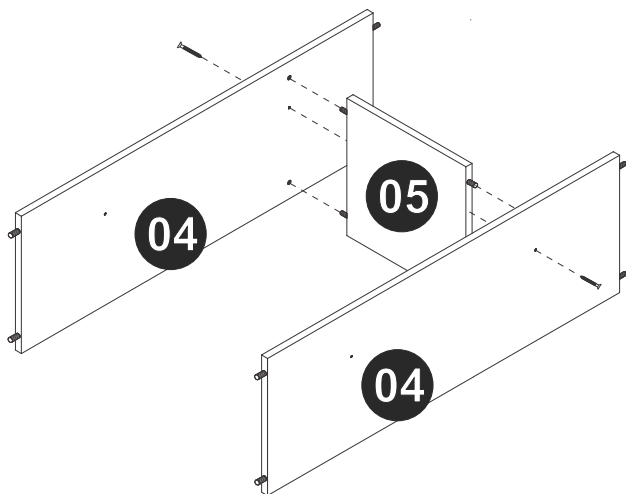

Conecte as peças 04 e 05 utilizando a ferragem EF 000132.
Connect pieces 04 and 05 using hardware EF 000132.
Junte las piezas 04 y 05 utilizando el herraje EF 000132.

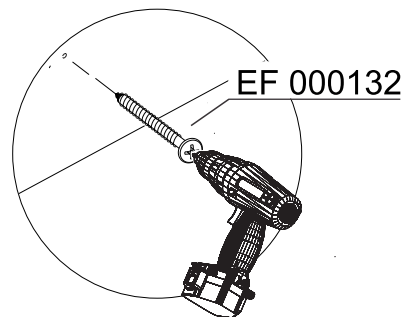

PASSO 5 / STEP 5 / PASO 5

Conecte as peças partes montadas nos passos 3 e 4 utilizando a peça 06, fixe as peças 05 utilizando a ferragem EF 000132, de acordo com a imagem.
Connect the parts assembled in the steps 3 and 4 using piece 06, fix pieces 05 using EF 000132, according the image.
Junte las partes armadas en los pasos 3 y 4 utilizando la pieza 06, fije las piezas 05 utilizando el herraje EF 000132, de acuerdo con la imagen.

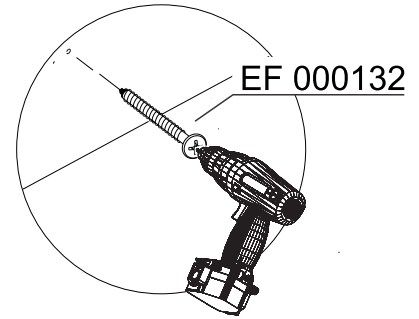
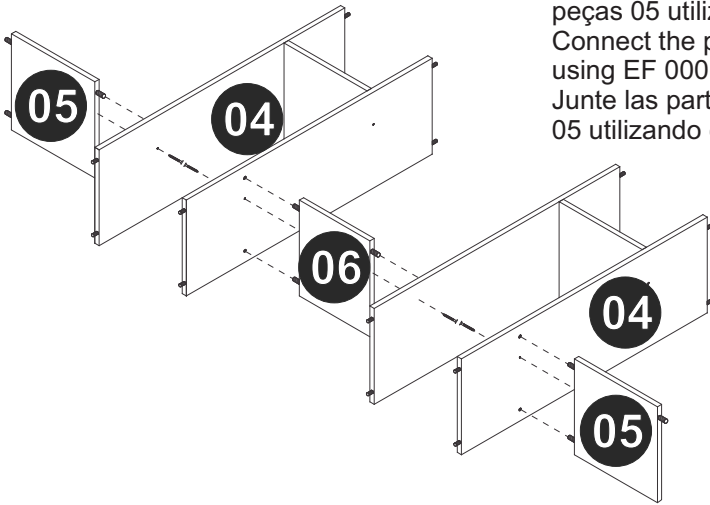

PASSO 6 / STEP 6 / PASO 6

Conecte as peças 04 e 05 à parte montada no passo anterior utilizando a ferragem EF 000132.
Connect piece 04 and 05 to the part assembled in the previous step using hardware EF 000132.
Junte la pieza 04 y 05 a la parte armada en el paso anterior utilizando el herraje EF 000132.

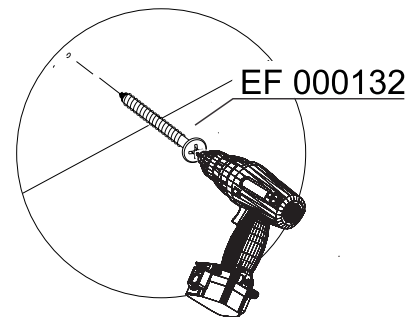
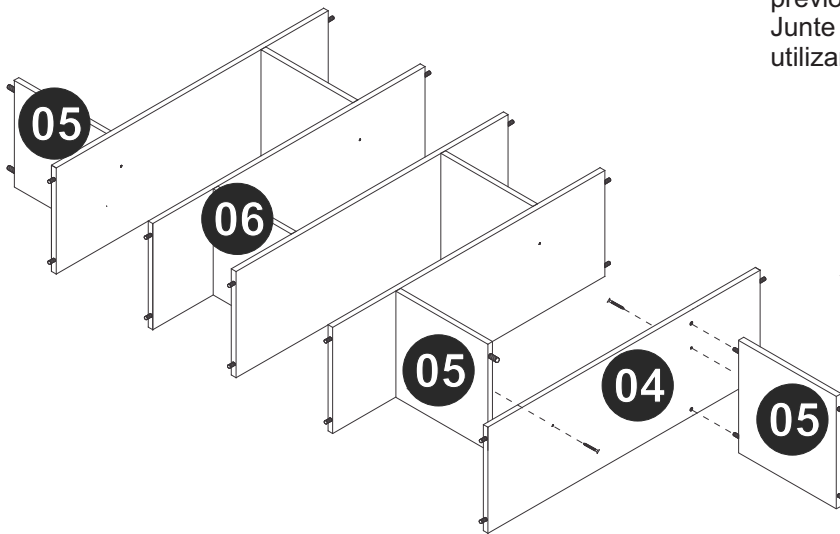

PASSO 7 / STEP 7 / PASO 7

Conecte as peças 01 à parte montada no passo anterior utilizando a ferragem EF 000132.
Connect piece 01 to the part assembled in the previous step using hardware EF 000132.
Junte la pieza 01 a la parte armada en el paso anterior utilizando el herraje EF 000132.

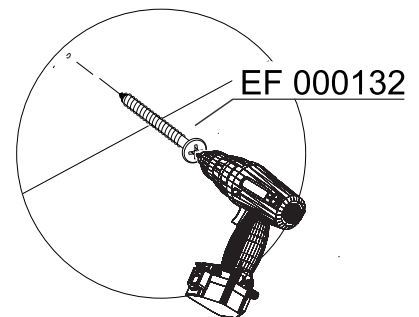
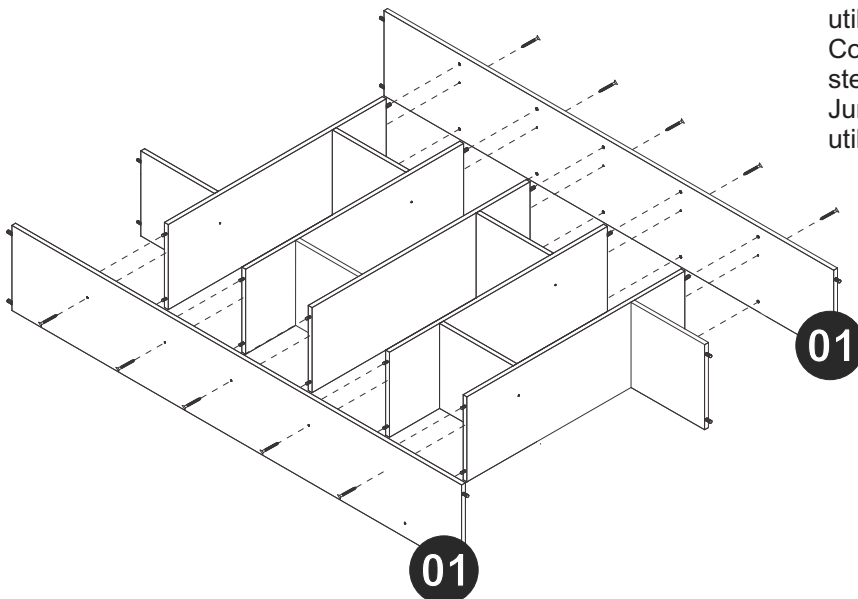

PASSO 8 / STEP 8 / PASO 8

Conecte as peças 02 e 03 à parte montada no passo anterior utilizando a ferragem EF 000132.
Connect piece 02 and 03 to the part assembled in the previous step using hardware EF 000132.
Junte la pieza 02 y 03 a la parte armada en el paso anterior utilizando el herraje EF 000132.

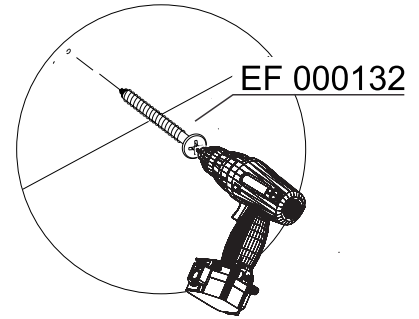
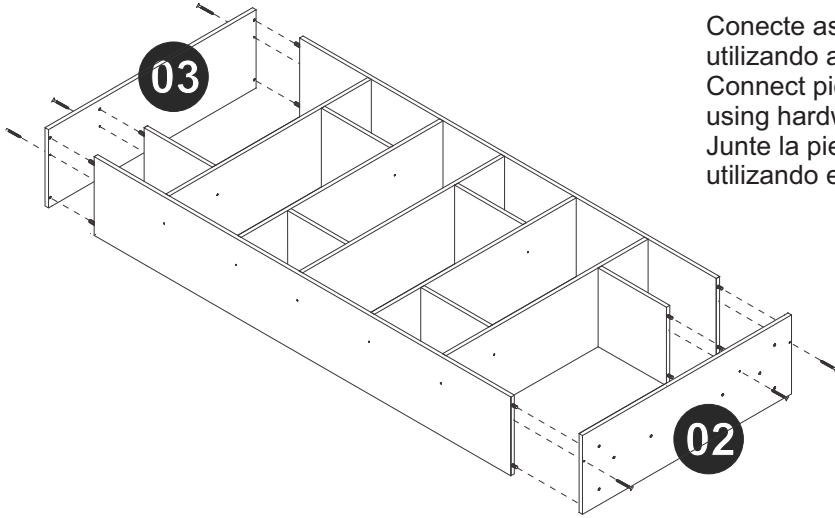

PASSO 9 / STEP 9 / PASO 9

Fixe as peças 08 na peça 02 utilizando as ferragens EF 000265 e EF 000106.
Fix pieces 08 at piece 02 using hardware EF 000265 and EF 000106.
Fije las piezas 08 en la pieza 02 utilizando los herrajes EF 000265 y EF 000106.

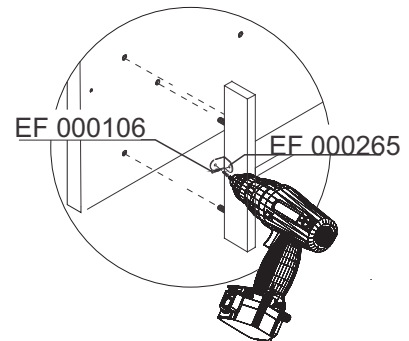
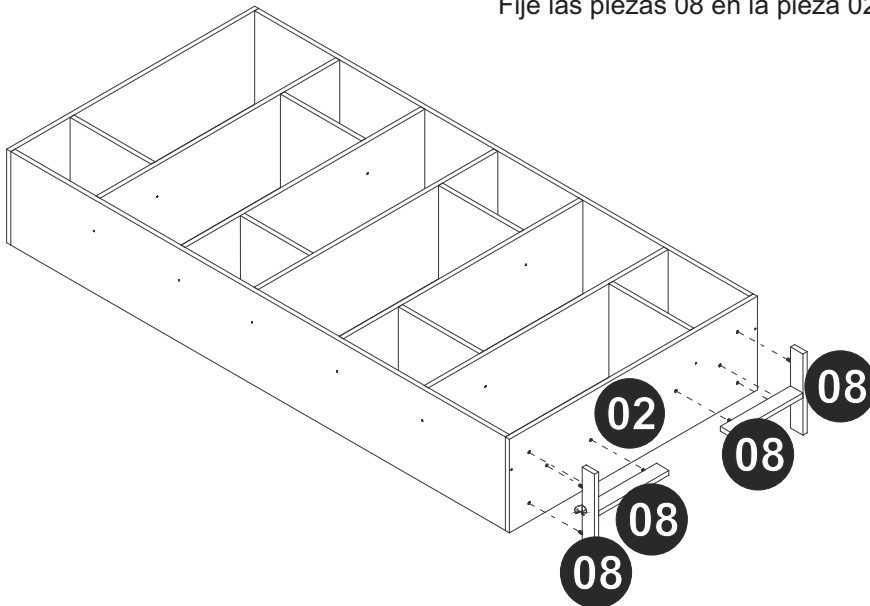

PASSO 10 / STEP 10 / PASO 10

Fixe os pés redondos utilizando a ferragem EF 000168.
Fix the round feet using hardware EF 000168.
Fije los pies redondos utilizando el herraje EF 000168.

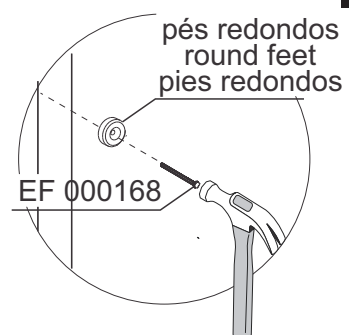
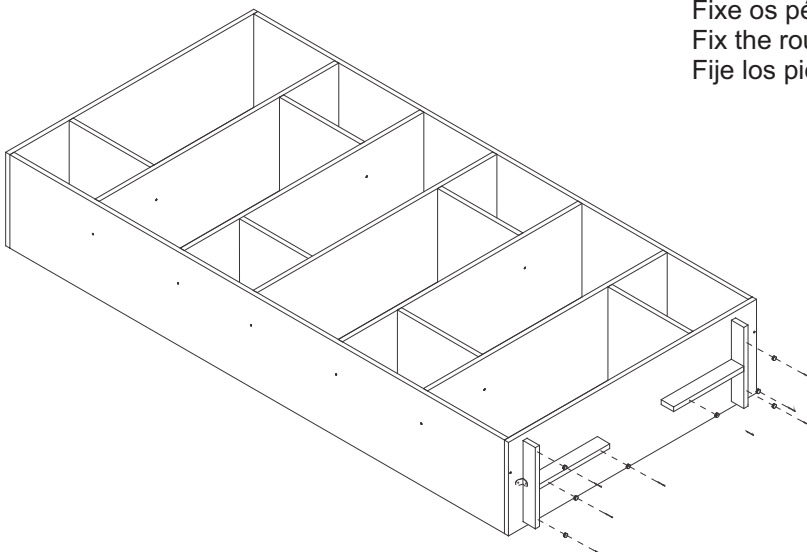

PASSO 11 / STEP 11/ PASO 11

Conecte as peças 07 ao móvel montado utilizando a ferragem EF 000168.
Connect pieces 07 to the part assembled furniture using hardware EF 000168.
Junte las piezas 07 al mueble armado utilizando el herraje EF 000168.

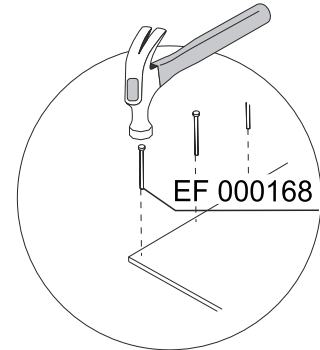
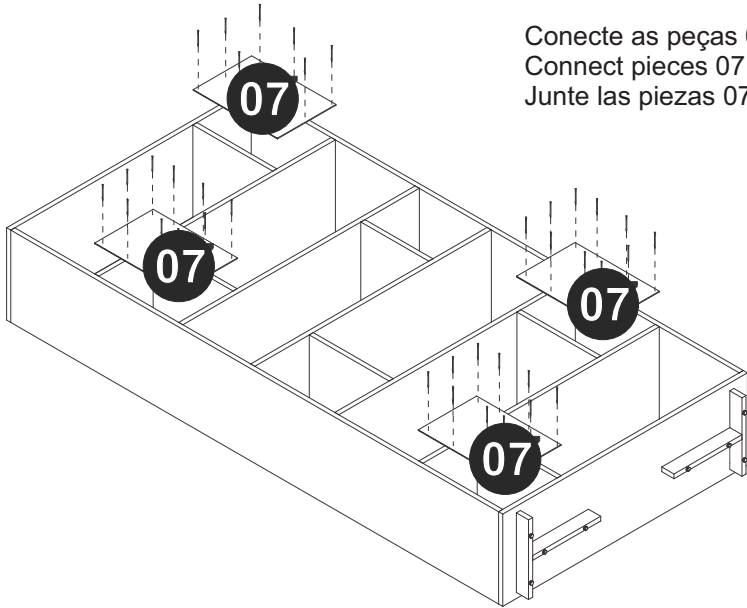

PASSO 12 / STEP 12 / PASO 12

Use o giz para dar o acabamento final ao produto. Use os tapa furos para cobrir os parafusos aparentes.
Use the chalk to give the final finish on the product. Use stickers to cover apparent screws.
Utilice la tiza para dar el acabado final al producto. Utilice los tapa huecos para cubrir los tornillos aparentes.

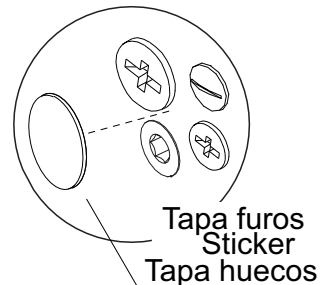
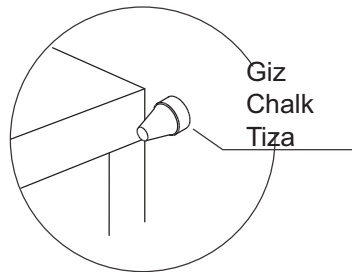
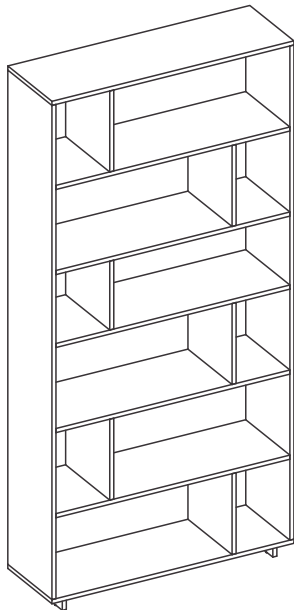

Agora que você já comprou o seu móvel, ele merece ser montado do jeito certo.

Erros de montagem causam mais de **60%** dos danos em móveis.

Por que contratar?

Tranquilidade do **início ao fim** da montagem



PROFISSIONAIS QUALIFICADOS

Especialistas certificados na **MadeiraMadeira Serviços**.



FERRAMENTAS PROFISSIONAIS

que **protegem** seus móveis.



AGENDAMENTO EM 24 HORAS

escolha a data e o turno **ideais para** você.



GARANTIA DE 3 MESES

de cobertura **completa**.

Mais de 1 MILHÃO DE MONTAGENS
★ com avaliação 4.7 ★

Mariana S., São Paulo

"Chegaram no horário e montaram tudo rapidamente. Serviço incrível!"



Carlos R., Belo Horizonte

"Tentei montar sozinho e foi um desastre. Com a **MadeiraMadeira Serviços** ficou perfeito."



Ana P., Rio de Janeiro

"Agendamento ágil e **montagem pontual e perfeita**. Recomendo demais!"



Agende agora pelo
QR Code

Madeira**Madeira** Serviços · Atendimento em todo o Brasil



Escaneie o QRCode