

Capacidade de Carga - Load Capacity - Capacidad de carga

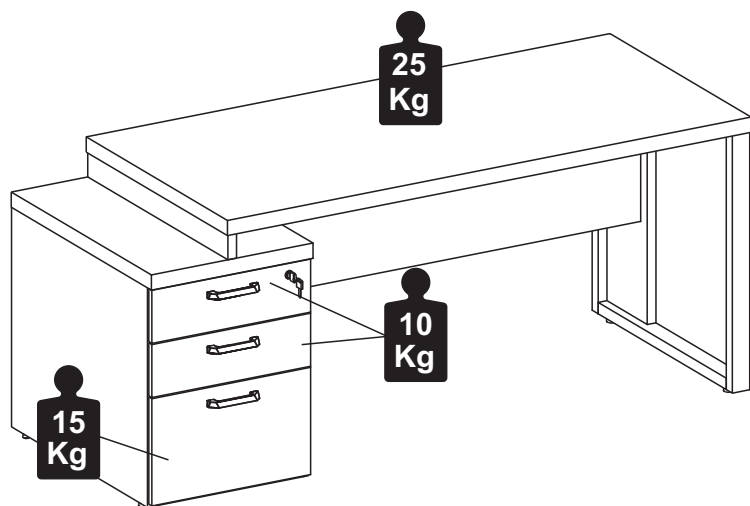

Manutenção e Limpeza

Vidros: pano levemente umedecido com álcool, seguido de pano seco.
Madeiras: pano levemente umedecido com água, seguido de pano seco.
*Nunca utilizar produtos químicos ou abrasivos.

Maintenance and Cleaning

Glasses: cloth lightly moistened with alcohol, followed by dry cloth.
Woods: cloth slightly moistened with water, followed by cloth seo.
*Never use chemicals or abrasives.

Mantenimiento y Limpieza

Vidrios: legeramente humedecido con alcohol, seguido de un paño seco.
Madera: ligeramente humedecido con agua, seguido de un paño seco.
*No utilice nunca productos quimicos o abrasivos.

INSTRUÇÕES DE MONTAGEM ASSEMBLY INSTRUCTIONS INSTRUCCIONES DE MONTAJE

GAVETEIRO DRAWERS CAJONERO

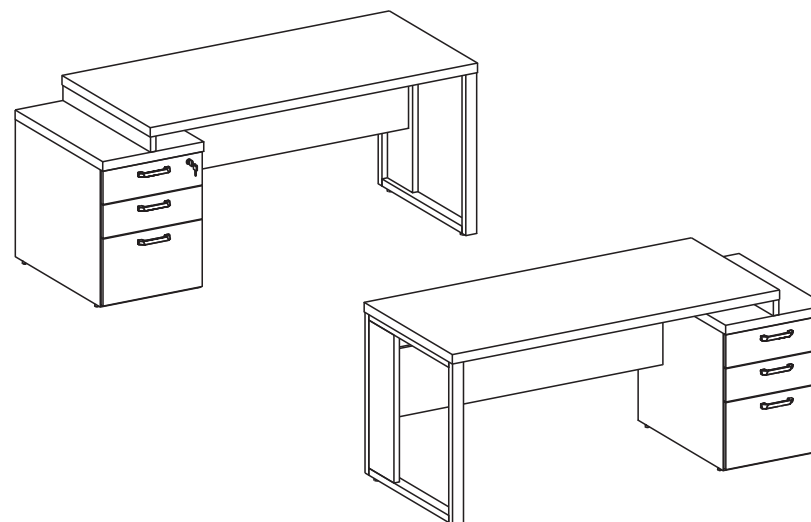

REF. #SAT 1573/1973

 **GEBB WORK**

MOBILIÁRIO PARA ESCRITÓRIO

GEBB Work Ind. de Móveis Ltda.
Rua Felix Roman, 190
São Valentin

95709-170 - Bento Gonçalves - RS - Brasil
Fone: (0XX54) 3454-1105 - (0XX54) 3453-1407
Phone: (0XX54) 3454-1105 - (0XX54) 3453-1407
E-mail: pedidos@gebbwork.com.br

www.gebbwork.com.br

WhatsApp: +55 54 99177-8324

LISTA DE PEÇAS

LISTA DE PEÇAS

- 01 - Lateral Direita
- 02 - Lateral Esquerda
- 03 - Tampo Engrossurado
- 04 - Base
- 05 - Frente Gaveta
- 06 - Frente Gaveta c/ Fech.
- 07 - Frente Gav. Maior
- 08 - Lateral Esq. Gaveta
- 09 - Lateral Dir. Gaveta
- 10 - Costa Gaveta
- 11 - Fundo Gaveta
- 12 - Lateral Esq. Gav. Maior
- 13 - Lateral Dir. Gav. Maior
- 14 - Costa Gav. Maior
- 15 - Costa
- 16 - Prateleira
- 17 - Divisória
- 18 - Base
- 20 - Tampo
- 21 - Painel Frontal
- 22 - Travessa Lateral
- 23 - Aplique
- 24 - Lateral Metálica
- 25 - Aplique Lateral

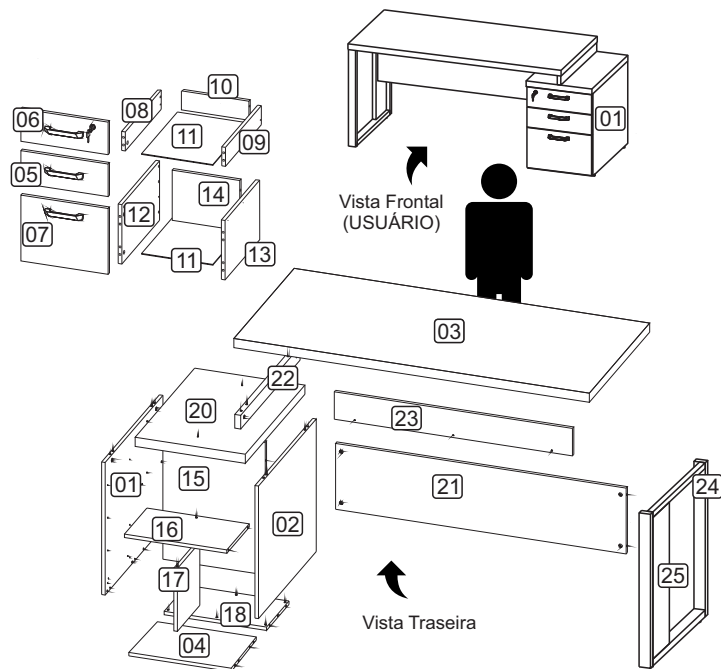

LISTA DE PIEZAS

- 01 - Lateral Derecha
- 02 - Lateral Izquierda
- 03 - Tampo Engrossado
- 04 - Base
- 05 - Frente Cajón
- 06 - Frente Cajón tranca
- 07 - Frente Cajón Mayor
- 08 - Lateral Izq. Cajón
- 09 - Lateral Der. Cajón
- 10 - Revés Cajón
- 11 - Fondo Cajón
- 12 - Lateral Izquierda Cajón mayor
- 13 - Lateral Derecha Cajón Menor
- 14 - Revés Cajón Mayor
- 15 - Costa
- 16 - Estante
- 17 - Divisoria
- 18 - Base
- 20 - Tampo
- 21 - Panel Frontal
- 22 - Travessa Lateral
- 23 - Aplique
- 24 - Lateral Metálica
- 25 - Aplique Lateral

PARTS IDENTIFICATION

- 01 - Right Side
- 02 - Left Side
- 03 - Cover
- 04 - Base
- 05 - Drawer Front
- 06 - Front Drawer Locks
- 07 - Large Front Drawer
- 08 - Left Drawer Side
- 09 - Right Drawer Side
- 10 - Drawer Back
- 11 - Drawer Bottom
- 12 - Large Left Side Drawer
- 13 - Large Right Side Drawer
- 14 - Drawer Back
- 15 - Coast
- 16 - Shelf
- 17 - Diviion
- 18 - Base
- 20 - Cover
- 21 - Front Panel
- 22 - Sid Dish
- 23 - Apply
- 24 - Metallic Side
- 25 - Side Fitting

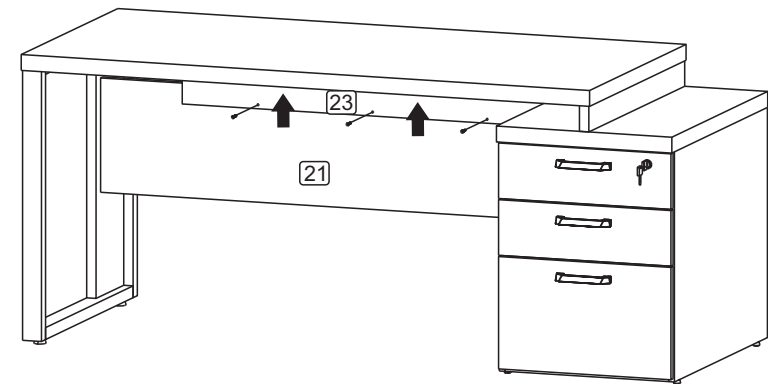

*Pressionar a peça (23) para cima para não empenar o tampo
 Presionar la pieza (23) hacia arriba para no empaquetar la tapa

ou

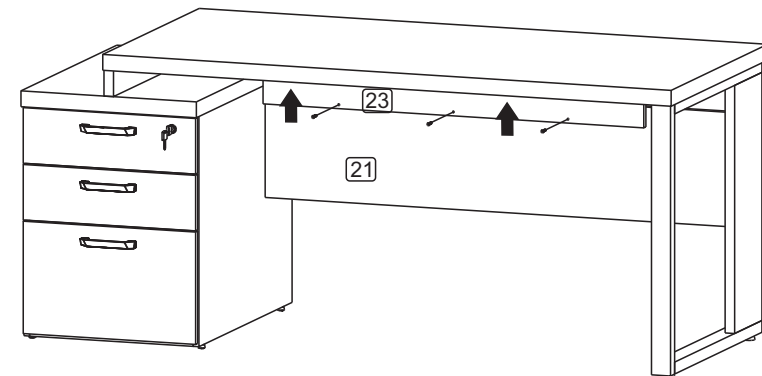

A4 - 3x

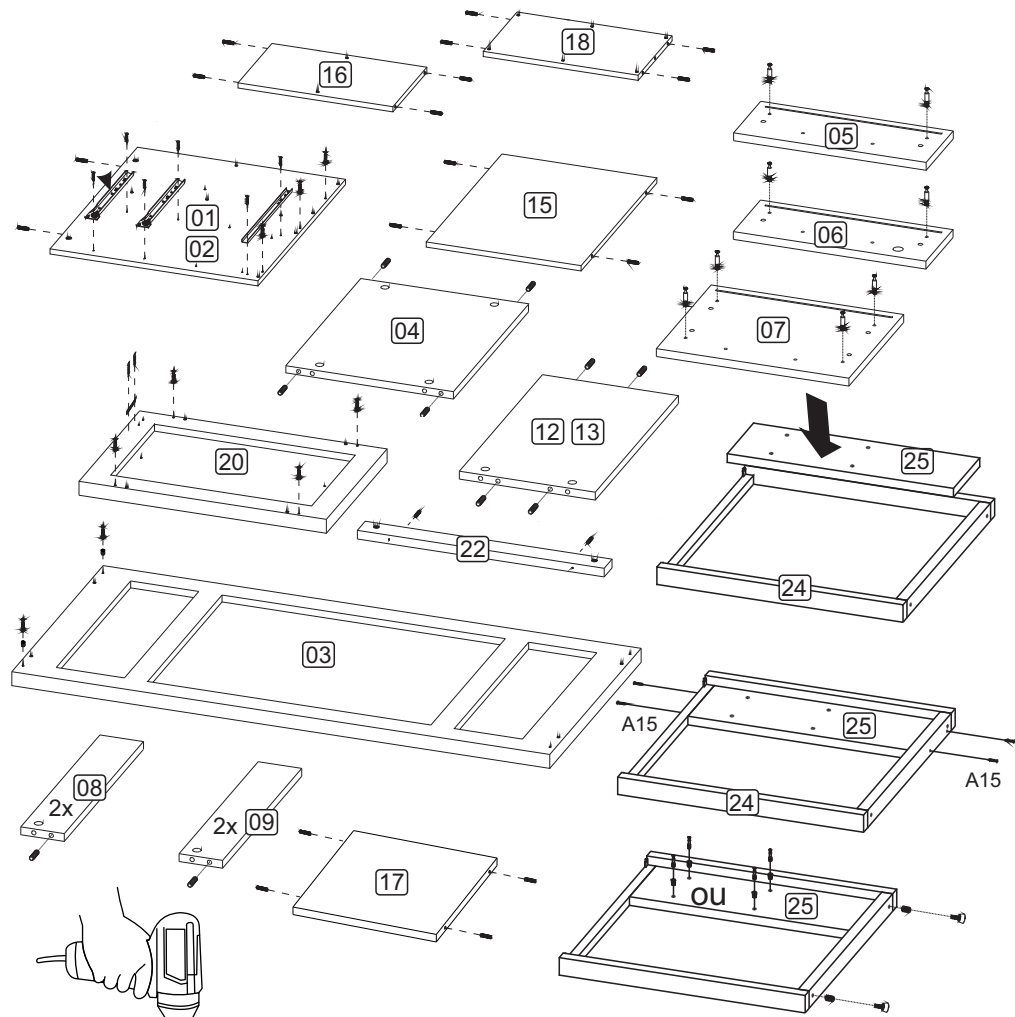

Usar ponteira de parafusadeira sextavada

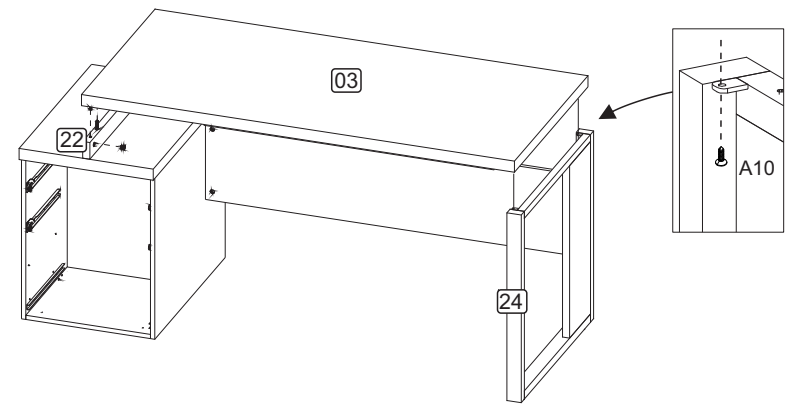
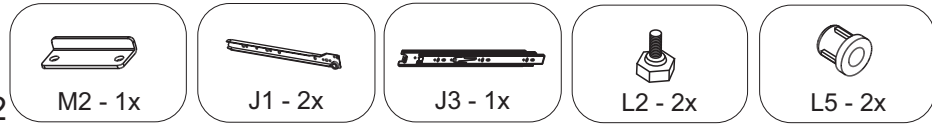
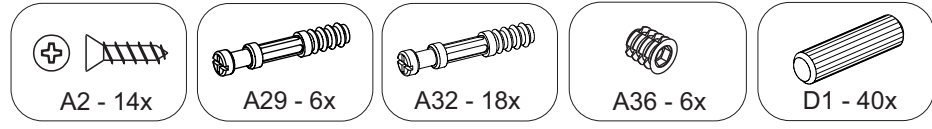
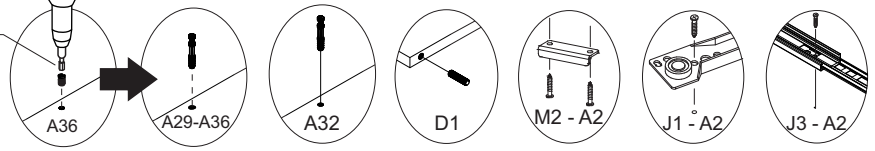
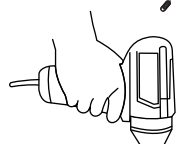

ou

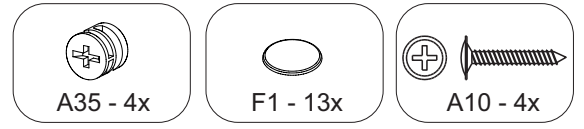
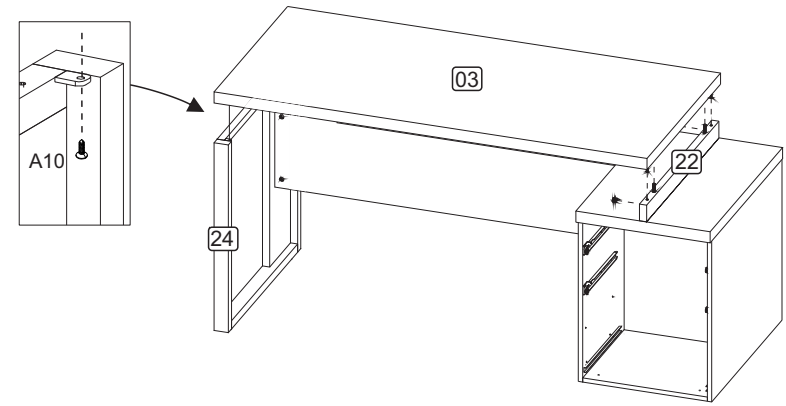

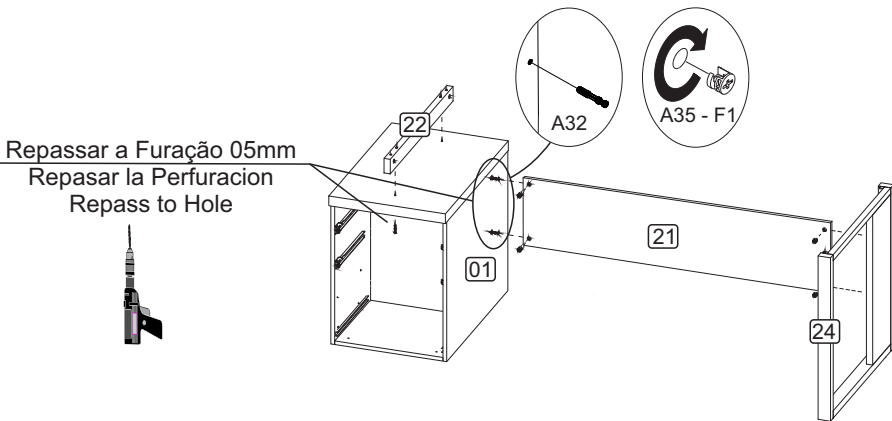

ou

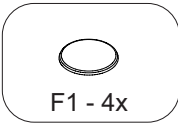
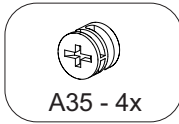
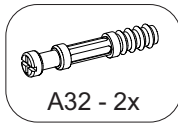
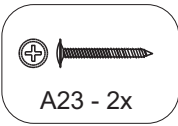
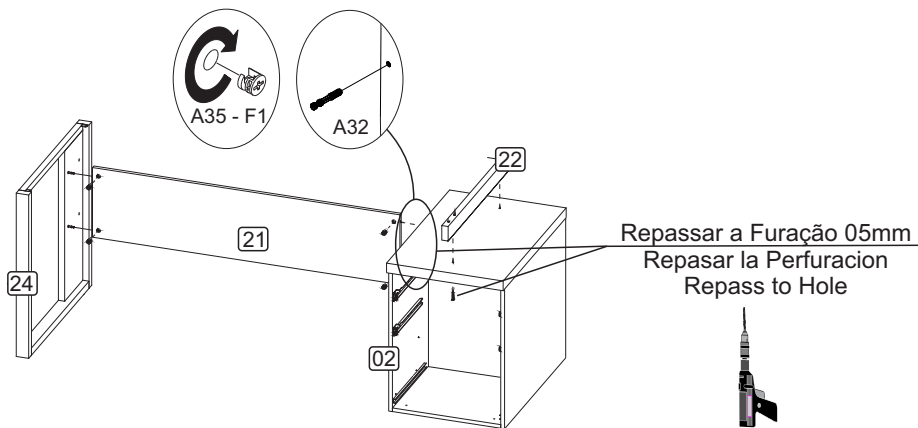

ACESSÓRIOS ACCESSORIES ACCESORIOS

A2 - PARAF. 3,5x14 CC
20x



A3 - PARAF. 3,5x20 CP
32x



A4 - PARAF. 3,5x25 CC
3x



A5 - PARAF. 3,5x25 CF
6x



A6 - PARAF. 3,5x40 CC
2x



A10 - PARAF. 4,0x20 CF
2x



A15 - PARAF. 4,0x40 CP
4x



A23 - PARAF. 5,0x35 CF
2x



A29 - PARAF. MINIFIX
M6x33m **6x**

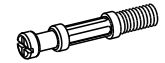

A32 - PARAF. MINIFIX
20x

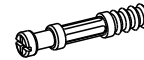

A35 - TAMBOR
MINIFIX **26x**



A36 - BUCHA M6x13
6x



B25 - SEPARADOR
P/ FECHADURA **1x**



B16 - HASTE MET.
353mm **2x**



C1 - PUXADOR
3x



D1 - CAVILHA 8x30
40x

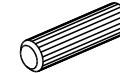

F1 - TAPA FURO ø18
25x



H6 - CANTONEIRA P/GAV
QUICK INSTALL **4x**



I1 - FECHADURA P/GAV.
1x



J1 - CORREDIÇA 350mm
2x



J3 - CORREDIÇA
TELESC. 350mm **1x**



L2 - SAPATA PLAST. SEXT. **2x**



L3 - SAPATA PLAST. 1/4
4x



L5 - BUCHA PLÁSTICA
P/SAPATA 5/16 **2x**



M2 - BATENTE P/PORTA
1x



M3 - CHAPA P/SAPATA
1/4" **4x**



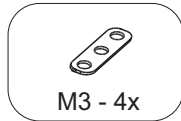
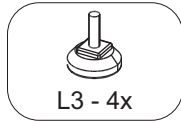
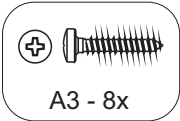
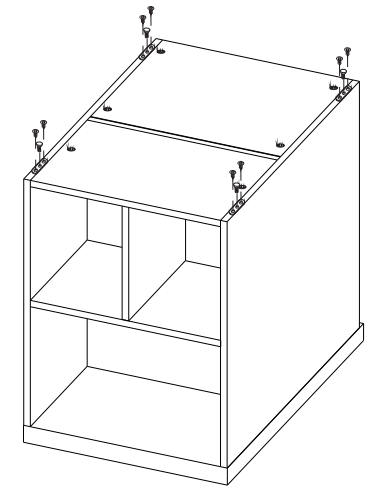
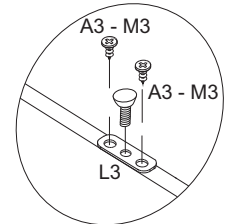
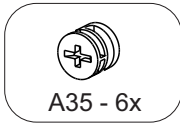
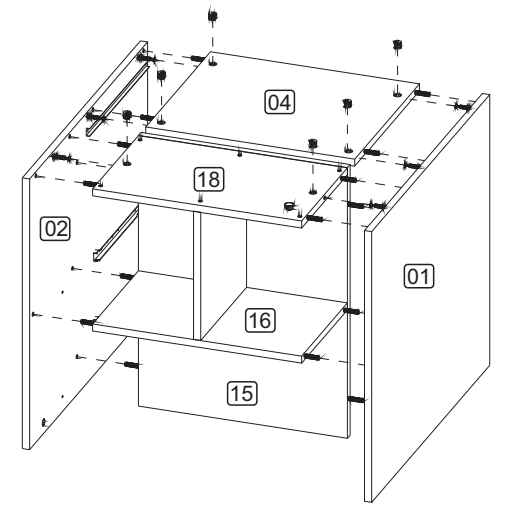
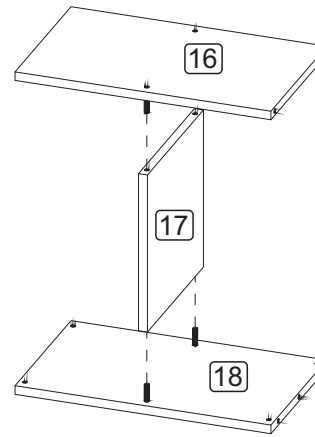
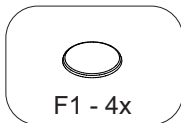
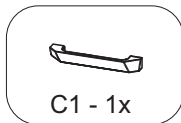
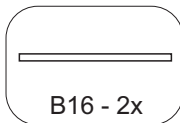
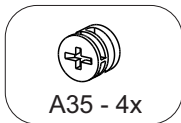
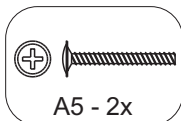
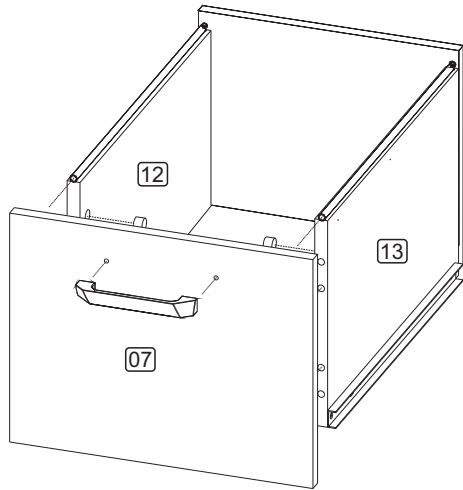

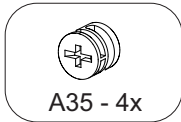
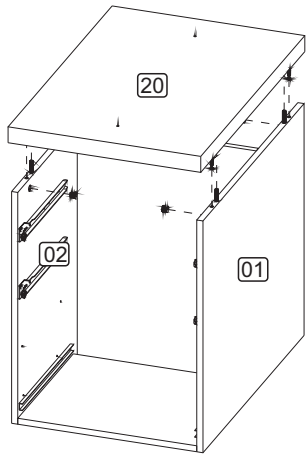

(2x)

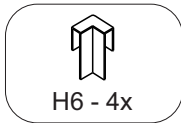
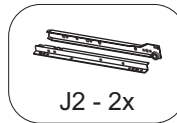
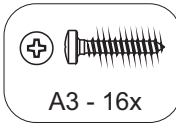
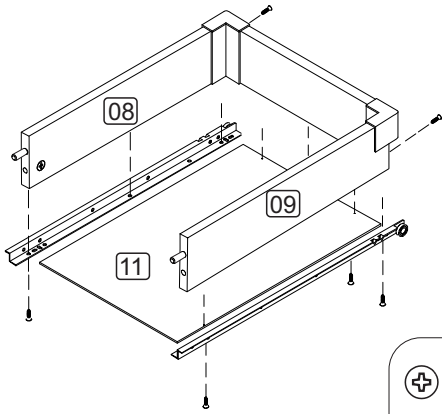
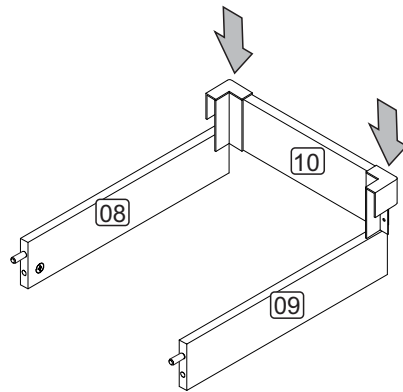
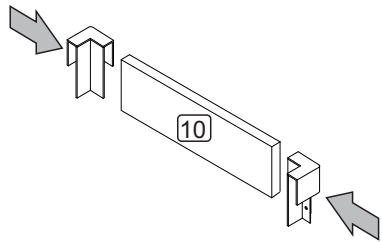

06/12

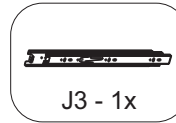
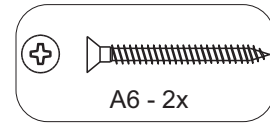
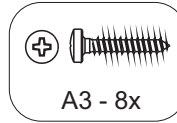
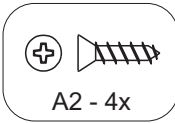
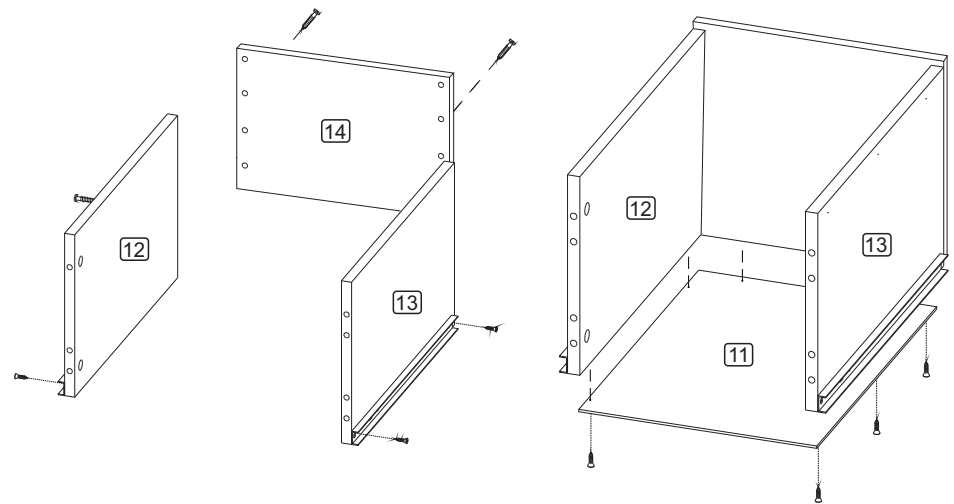
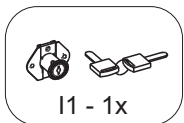
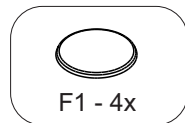
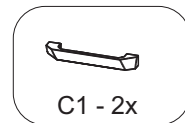
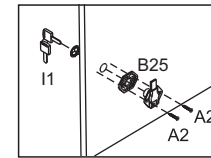
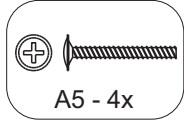
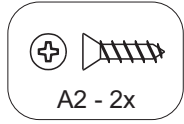
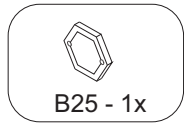
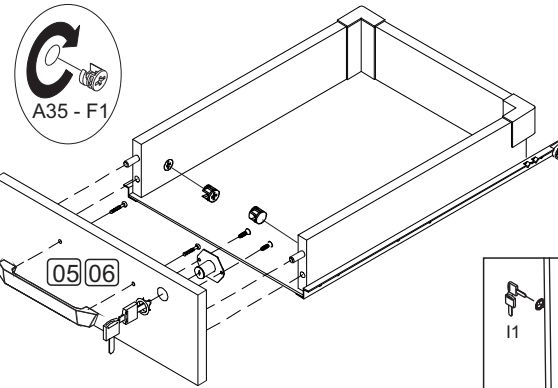

07/12