



Ind. e Com. de Móveis Henn
Mondai - SC - Brasil

+55 49 3674.3500

@moveishenn
www.henn.com.br

INSTRUÇÕES DE MONTAGEM

INSTRUCCIONES DE MONTAJE
ASSEMBLY INSTRUCTIONS

Roupeiro 03 Portas e 02 Gavetas | Armario 03 puertas y 02 cajones | Wardrobe 03 Doors 02 Drawers

- BS05-127 Nature/Off White
- BS05-130 Castanho HP



Pesos máximos recomendados com carga distribuída
Peso máximo recomendado con la carga distribuida
Recommended maximum weights with evenly distributed.

AVISO

Para limpeza de seu móvel, use uma flanela seca ou umedecida, e não utilize produtos químicos que possam danificar seu produto.

SISTEMA DE MONTAGEM

O sistema de montagem dos produtos, funciona de acordo com a ordem crescente dos números indicados no desenho. Ex: 01, 02, 03, 04... até a conclusão da montagem.

ASSISTÊNCIA TÉCNICA

Para solicitação de Assistência Técnica você consumidor deverá entrar em contato com o Lojista o qual você realizou a compra deste produto e solicitar a assistência técnica das peças avariadas. A garantia abrange todas as peças, partes e componentes que eventualmente venham apresentar defeito de fabricação no prazo de 03 (três) meses, contando a partir da entrega do produto ao consumidor, mediante nota fiscal de compra. Se houver qualquer alteração na estrutura do produto ou ocorrer defeito por negligência do montador/consumidor em relação a instrução de montagem e manuseio, não será fornecido assistência técnica gratuita.

ADVERTENCIA

Para limpeza de su móvil, use una flanela seca o húmeda, y no utilice productos químicos que puedan dañar su producto.

SISTEMA DE MONTAJE

El sistema de montaje de los productos funciona de acuerdo con el orden creciente de los números indicados en el dibujo. Ej.: 01, 02, 03, 04... hasta la conclusión del montaje.

ASSISTENCIA TÉCNICA

Para solicitar Asistencia Técnica, el consumidor debe comunicarse con el Comercio que usted realizó la compra de este producto y solicita asistencia técnica para las partes dañadas. La garantía cubre todas las partes, piezas y componentes que eventualmente puedan presentar defecto de fabricación en el plazo de 03 (tres) meses, contados a partir de la entrega del producto al consumidor, mediante factura de compra. Si se produce algún cambio en la estructura del producto o se produce un defecto por negligencia del montador/consumidor en relación con las instrucciones de montaje y manipulación, no se prestará asistencia técnica gratuita.

NOTICE

To clean your furniture, use a dry or wet cloth, and do not use chemicals that may damage your product.

ASSEMBLY SYSTEM

The products' assembly system works according to the increasing order of the indicated numbers. For example: 01, 02, 03, 04 ... to the end of the assembly.

TECHNICAL ASSISTANCE

To request Technical Assistance, the consumer must contact the retailer from whom you purchased this product and request technical assistance for the damaged parts. The warranty covers all parts, parts and components that may eventually present a manufacturing defect within a period of 03 (three) months, counting from the delivery of the product to the consumer, by means of a purchase invoice. If there is any change in the structure of the product or defect occurs due to negligence of the assembler/consumer in relation to the assembly and handling instruction, free technical assistance will not be provided.

Requisitos para montagem

Requisitos para la montaje

Assembly Requirements

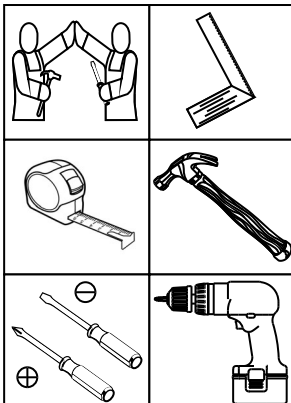

Imagens meramente ilustrativas,
não acompanha o produto.
Imágenes ilustrativas, no incluidas
con el producto.
Illustrative images, not included
with the product.

1º

Vista Inferior

Vista Inferior

Bottom view

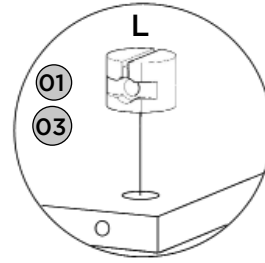
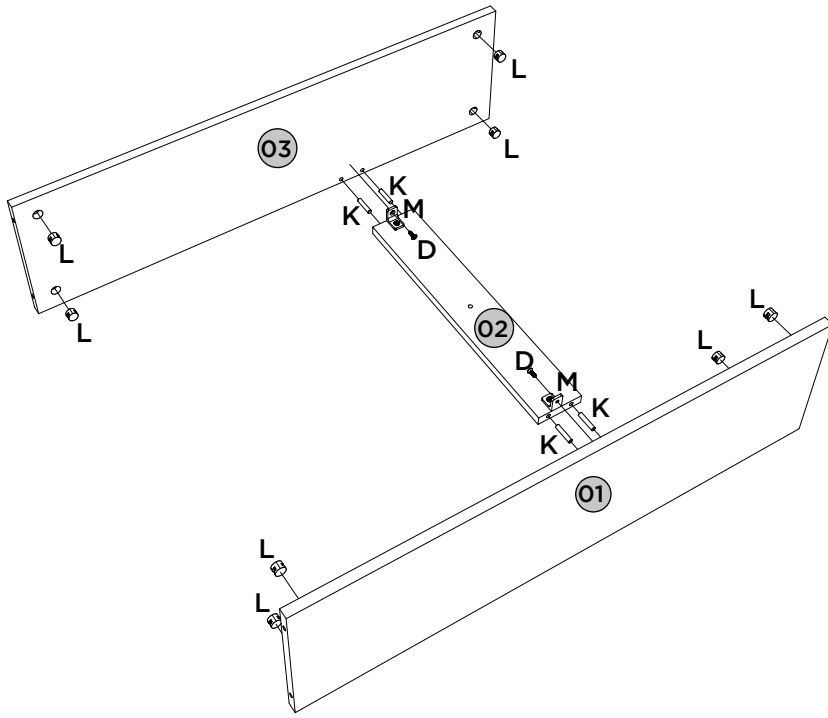

Distância menor da furação para frente

Distancia de orificio más pequeña hacia adelante

Smaller hole distance forward

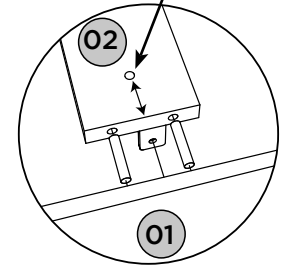
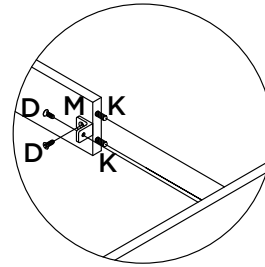

2º

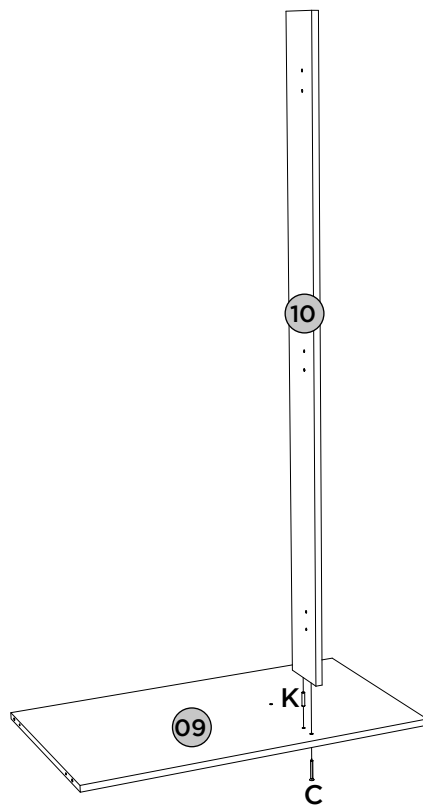

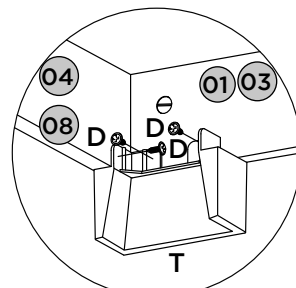
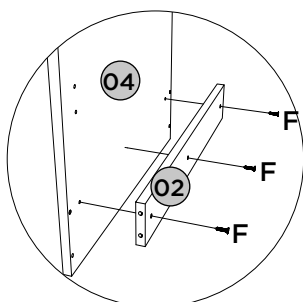
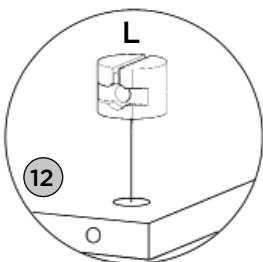
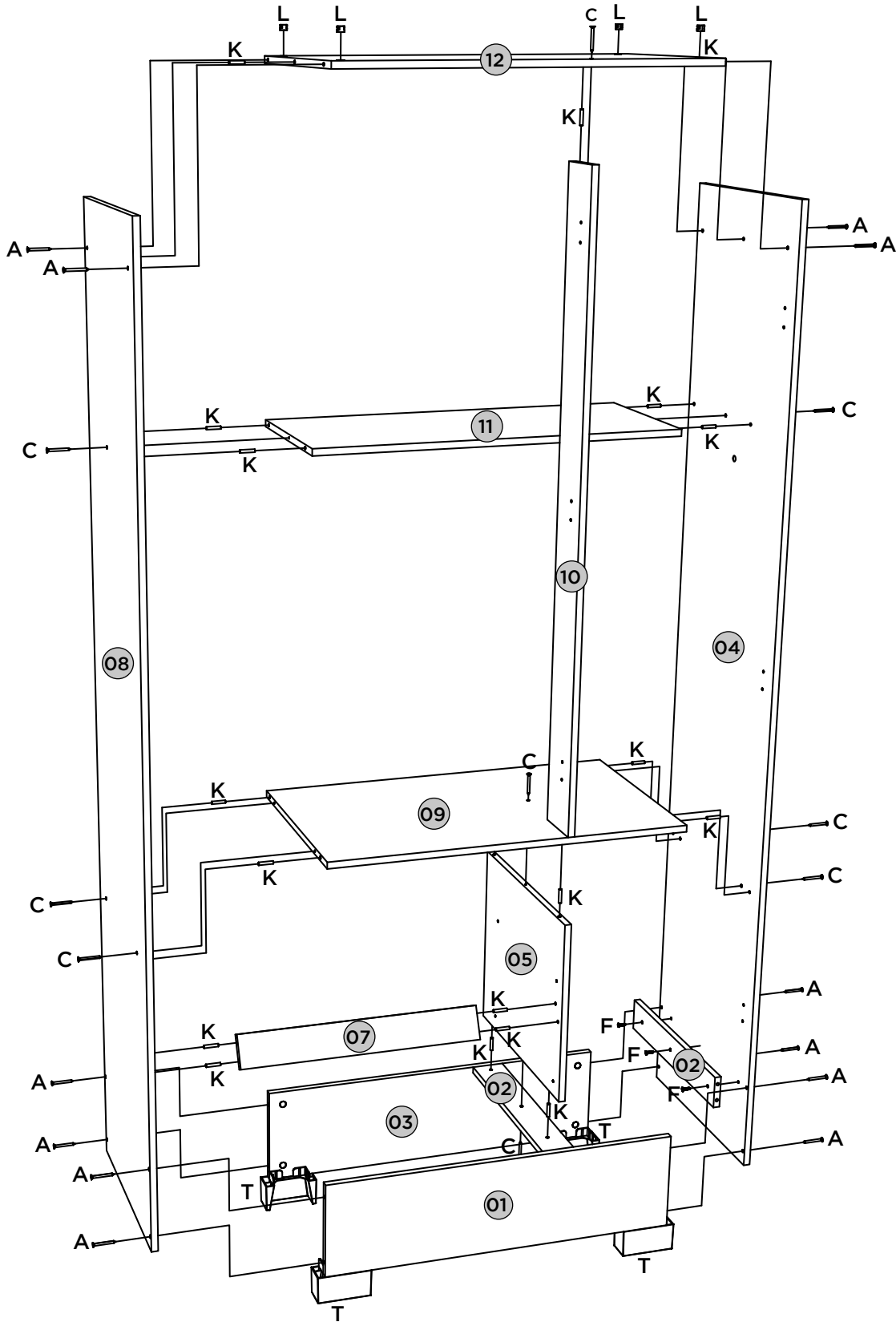

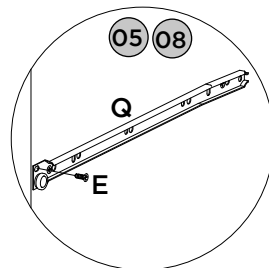
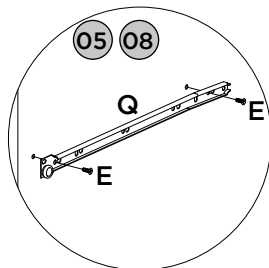
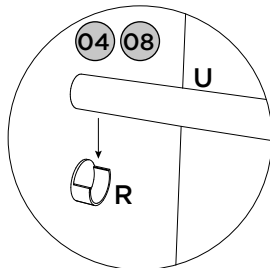
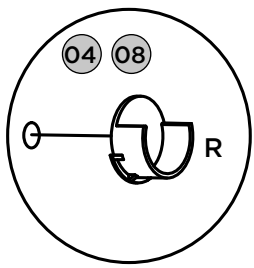
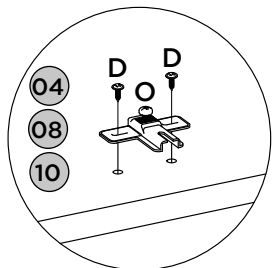
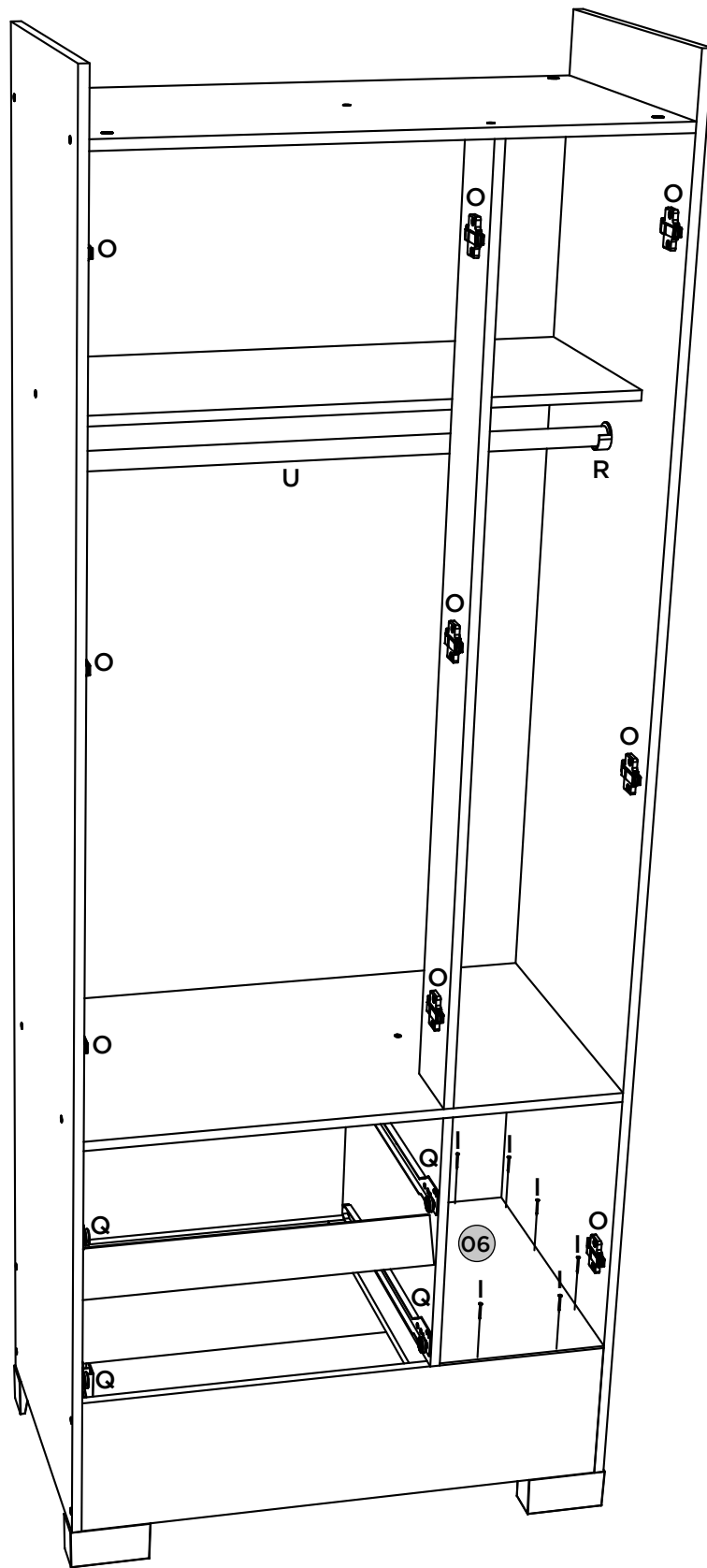

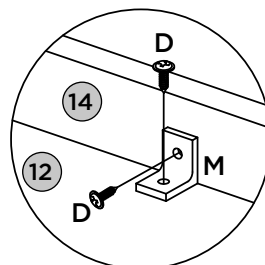
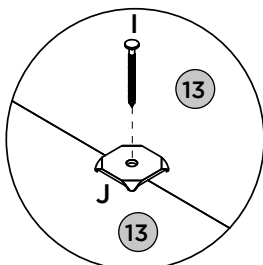
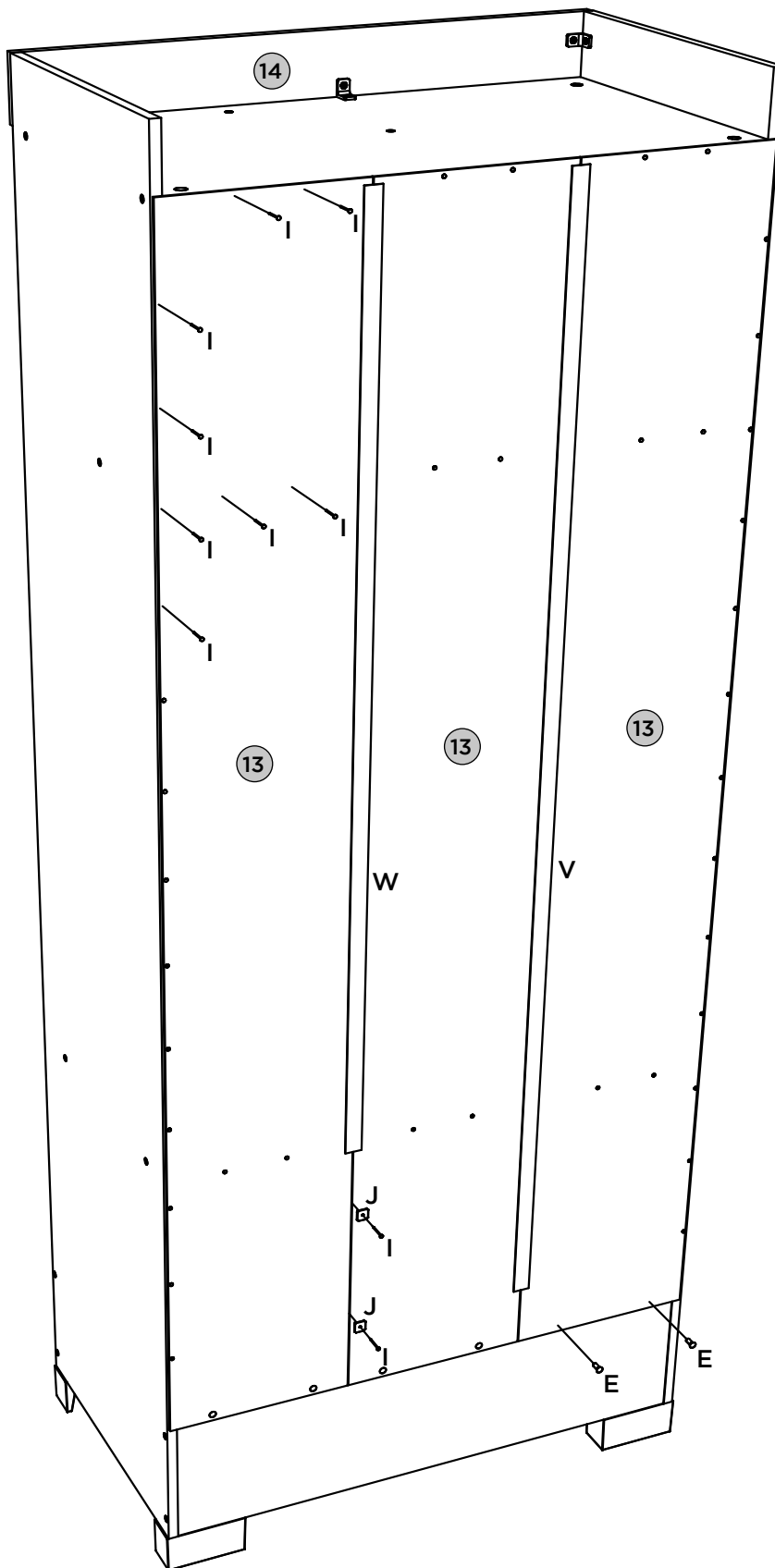

Fixar os pregos a uma distância de 120mm de um para outro.

Fijar las uñas a un distancia de 120mm uno a otro.

Fix the nails at a distance of 120mm from one to the other

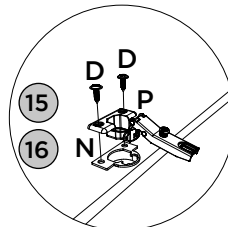
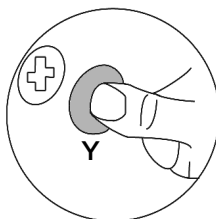
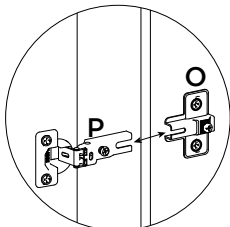
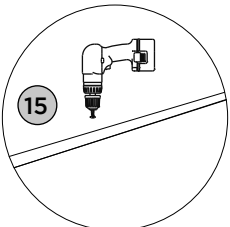
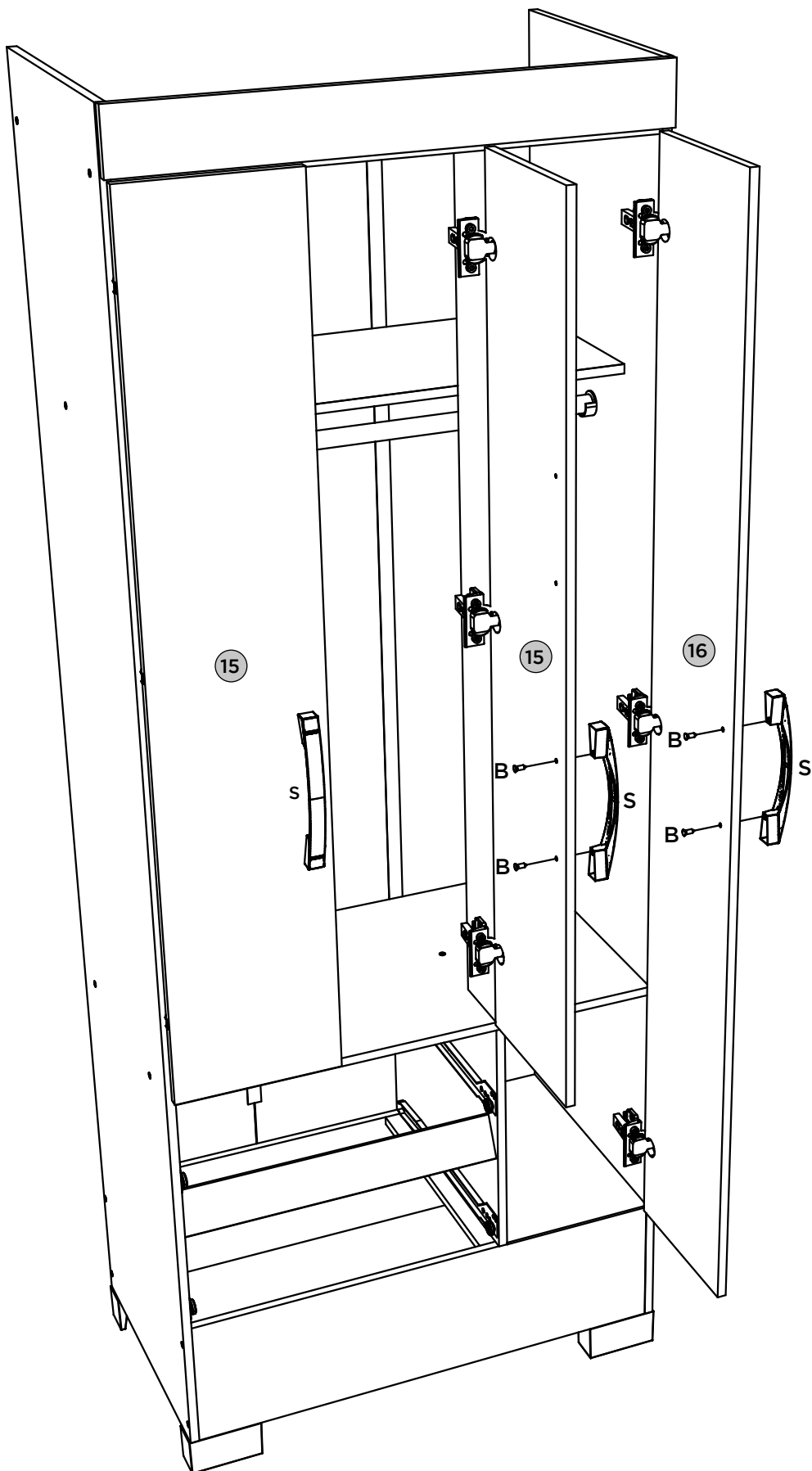

Importante a colocação do Distanciador (N).

Es importante colocar el Espaciador (N).

It is important to place the (N) Spacer.

7°



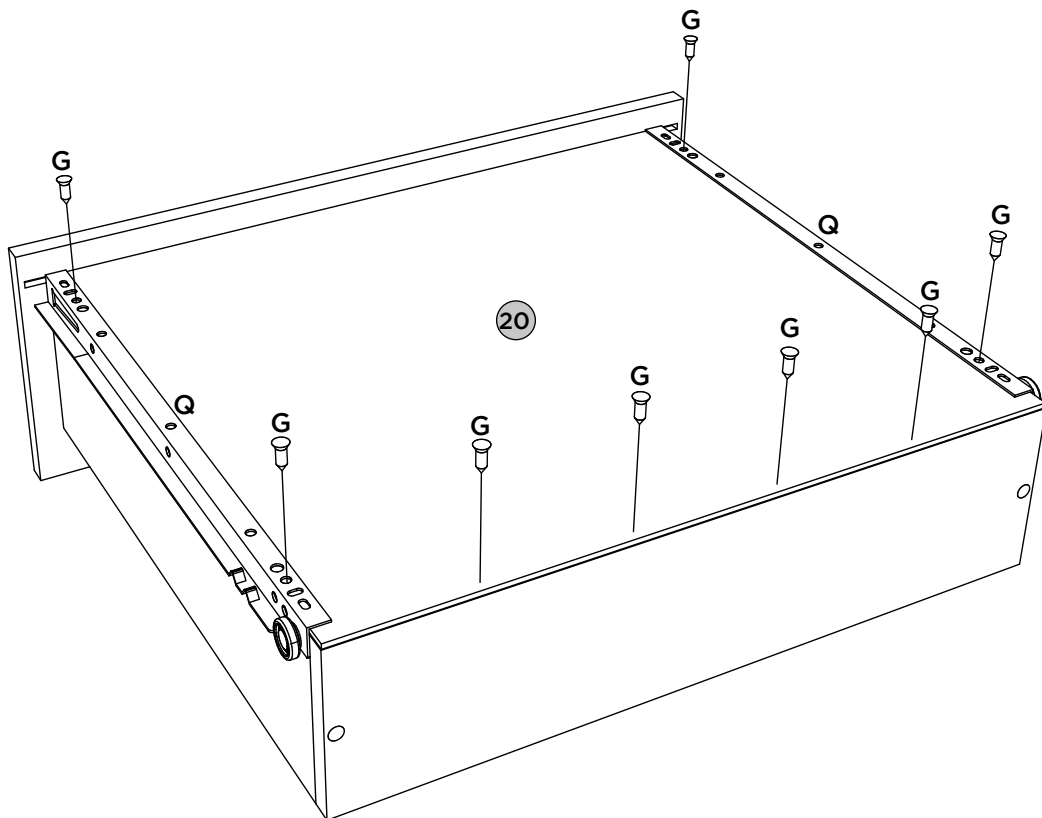
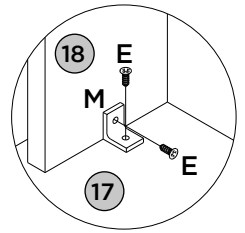
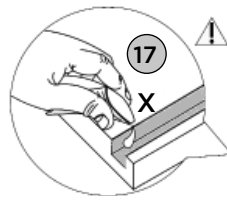
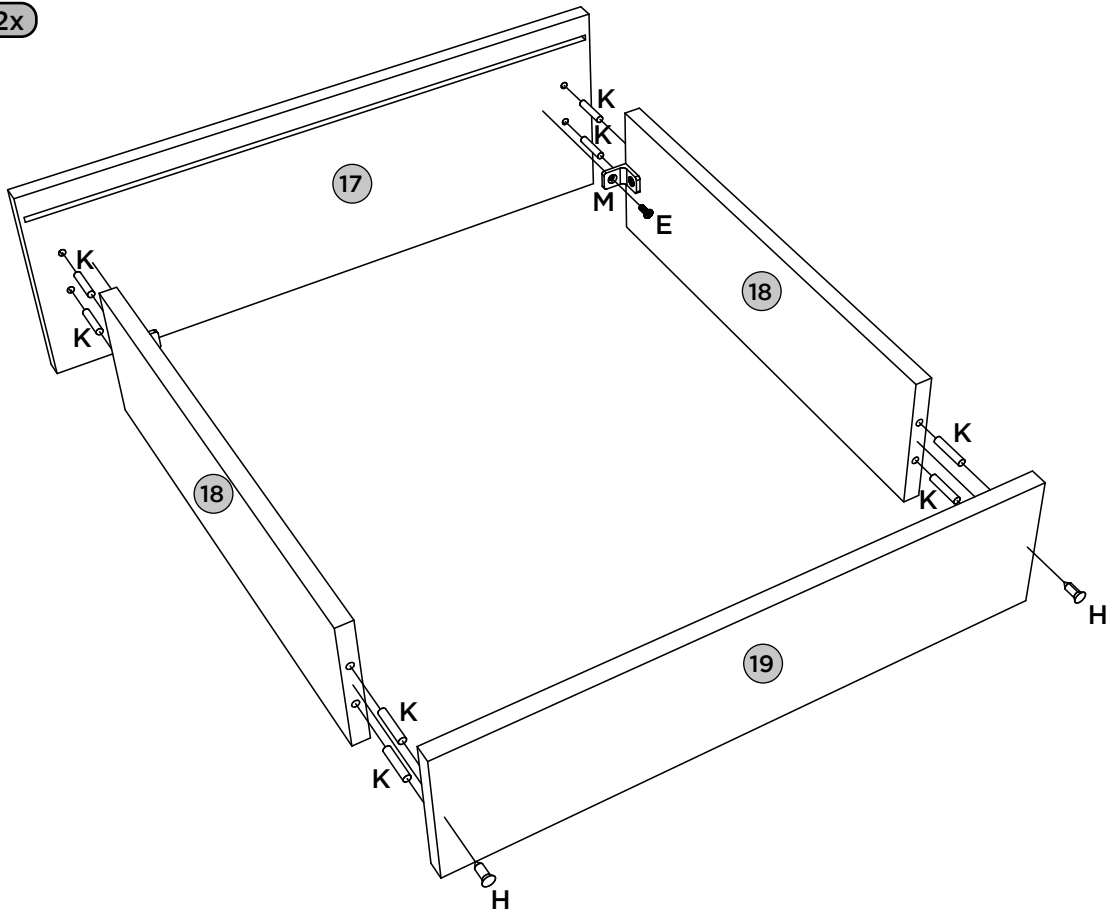













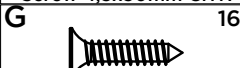

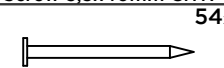
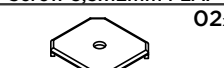

2x



LISTA DE PEÇAS | LISTA DE PIEZAS | PARTS LIST

Item	Caixa Caja Box	Qtd Ctd Qty	Descrição Descripción Description	Medidas (mm) Dimensions (mm) Size (measurements) (mm)
01	1/1	01	Rodapé frontal Pie frontal Front footboard	656x180x12
02	1/1	01	Travessa base travesaño base base crosspiece	354x60x12
03	1/1	01	Rodapé traseiro Pie trasero Rear footboard	656x180x12
04	1/1	01	Lateral direita Lateral derecho Right side	1750x380x12
05	1/1	01	Divisão das gavetas División de cajones Drawers division	338x380x12
06	1/1	01	Base 3mm Base 3mm Base 3mm	211x380x3
07	1/1	01	Travessa Frontal Travesaño delantero Front Tray	433x60x12
08	1/1	01	Lateral esquerda Lateral izquierda Left side	1750x380x12
09	1/1	01	Tampo das Gavetas Cubre los cajones Drawer Top	656x380x12
10	1/1	01	Pilastra da porta Puerta Pilastra Door pilaster	1132x95x12
11	1/1	01	Prateleira Estante Shelf	656x285x12
12	1/1	01	Tampo Cubierta Cover	656x380x12
13	1/1	03	Fundo Fondo Bottom	1506x224x3
14	1/1	01	Chapéu Sombrero Hat	678x80x12
15	1/1	02	Porta menor puerta más pequeña Smaller door	1140x220x12
16	1/1	01	Porta Puerta Door	1490x220x12
17	1/1	02	Frente de gaveta Frente de cajón Drawer front	443x152x12
18	1/1	04	Lado de gaveta Lado del cajón Drawer side	350x100x12
19	1/1	02	Ripa de trás Malla detrás Rear batten	408x100x12
20	1/1	02	Fundo de gaveta Fondo del cajón Drawer bottom	407x367x3

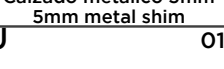
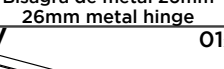
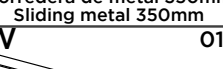
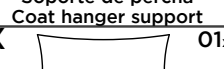
FERRAGENS | HERRAJES | HARDWARE

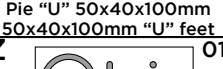
A  12x Parafuso 4,5x50mm CHT. Tornillo 4,5x50mm CHT. Screw 4,5x50mm CHT.	B  06x Parafuso 3,5x25mm FLA. Tornillo 3,5x25mm FLA. Screw 3,5x25mm FLA.	C  10x Parafuso 3,5x40mm CHT. Tornillo 3,5x40mm CHT. Screw 3,5x40mm CHT.	D  58x Parafuso 3,5x12mm FLA. Tornillo 3,5x12mm FLA. Screw 3,5x12mm FLA.	E  26x Parafuso 3,5x12mm CHT. Tornillo 3,5x12mm CHT. Screw 3,5x12mm CHT.	F  03x Parafuso 3,0x20mm CHT. Tornillo 3,0x20mm CHT. Screw 3,0x20mm CHT.
G  16x Parafuso 3,0x16mm CHT. Tornillo 3,0x16mm CHT. Screw 3,0x16mm CHT.	H  04x Prego 12x12mm Anelado Clavo 12x12mm Anillado Ringed Nails 12x12mm	I  54x Prego 10x10mm Clavo 10x10mm Nail 10x10mm	J  02x Fixador de fundos Fijador de fondos Bottom fixer	K  40x Cavilha 5x25mm Cinta 5x25mm Dowel 5x25mm	L  12x Porca cilíndrica Tuerca cilíndrica Cylindrical nut
M  09x Cantoneira plástica Cantenera plástica Plastic angle brackets	N  09x Distanciador de dobradiça Espaciador de bisagra Hinge Spacer	O  09x Calço metal 5mm Calzado metálico 5mm 5mm metal shim	P  09x Dobradiça metal 26mm Bisagra de metal 26mm 26mm metal hinge	Q  PAR 02x Corrediza metal 350mm Corredera de metal 350mm Sliding metal 350mm	R  02x Suporte cabideiro Soporte de percha Coat hanger support
S  03x Puxador Indonésia 128mm Tirador Indonésia 128mm 128mm Indonésia Handle	T  04x Pé "U" 50x40x100mm Pie "U" 50x40x100mm 50x40x100mm "U" feet	U  01x Cabideiro Madeira 650mm Cabezal Madera 650mm 650mm wooden hanger	V  01x Perfil "I" 1418mm Perfil "I" 1418mm Profile "I" 1418mm	W  01x Perfil "I" 1154mm Perfil "I" 1154mm Profile "I" 1154mm	X  01x Sachê de cola Bolsa de pegamento Glue bag
Y  20x Adesivo tapa parafuso 10mm Adhesivo tapón de tornillo 10mm Bolt cover adhesive 10mm	Z  01x Etiqueta resinada Briz Etiqueta resinada Briz Briz resin label				



KIT ESPELHO 800x165x3 COM 2 UNIDADE

c B951-64 - Prata

Item	Caixa	Qtd	Descrição	Medidas (mm)
01	1/1	02	Espelho	800x165x3

Exemplo: Porta Menor
1146x245x12
(BS01-127/130 Roupeiro
06 Portas 02 Gavetas)

Ferragens

A		04x	B		04x
Suporte Bucha Cromada fixador espelho 3,5mm			Parafuso 3,5x14mm FLA Cromado		

AVISO

Para limpeza de seu móvel, use uma flanela seca ou umedecida, e não utilize produtos químicos que possam danificar seu produto.

SISTEMA DE MONTAGEM

O sistema de montagem dos produtos, funciona de acordo com a ordem crescente dos números indicados no desenho. Ex: 01, 02, 03, 04... até a conclusão da montagem.

Medidas em mm

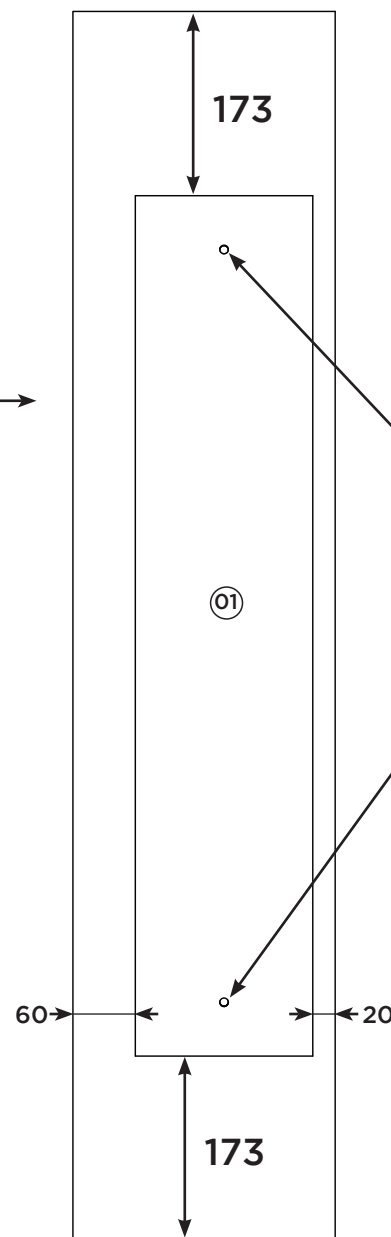

Fixar o Espelho com a Bucha (A) e o Parafuso (B)
Utilizar a parafusadeira com o torque 3.

Requisitos para montagem

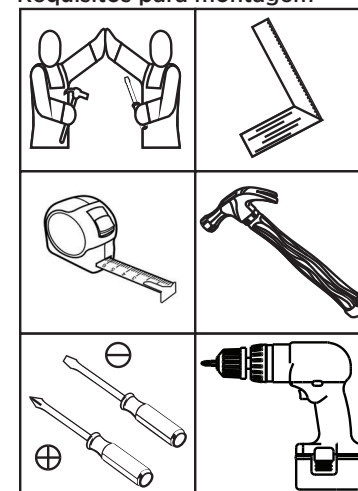

Imagens meramente ilustrativas