

**Roupeiro 04 Portas e 02 Gavetas | Armario 04 puertas y 02 cajones |
Wardrobe 04 Doors 02 Drawers**

- BE12-10 Branco
- BE12-46 Preto Tex/Branco
- BE12-74 Gris/Palha
- BE12-76 Gris
- BE12-86 Branco Fosco
- BE12-87 Chocolate Fosco
- BE12-94 Rústico
- BE12-101 Café

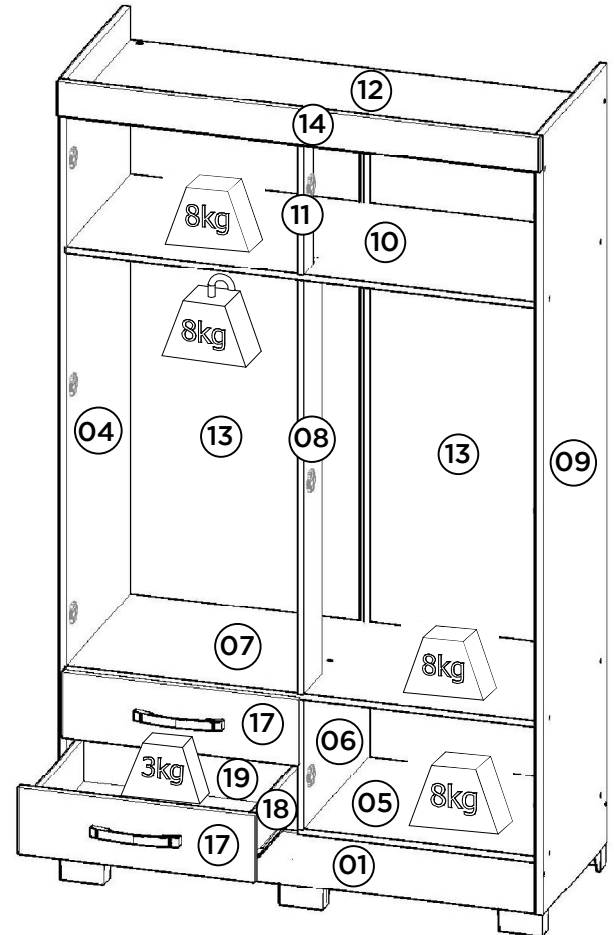

**Requisitos para montagem
Requisitor para la montaje
Assembly Requirements**

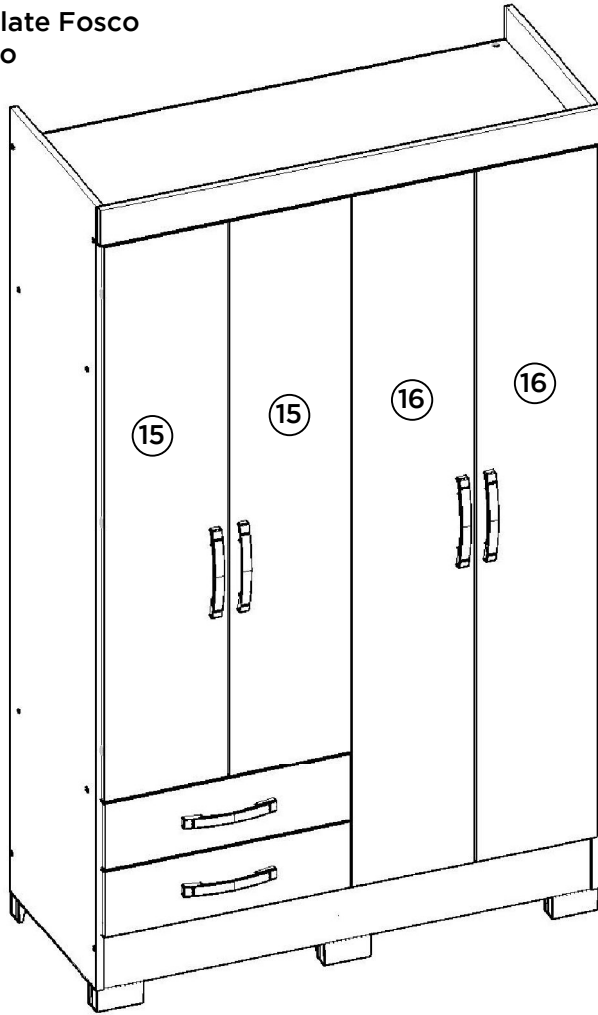
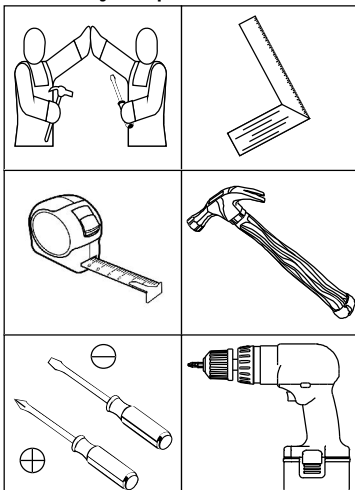

Imagens meramente ilustrativas
Imágenes meramente ilustrativas
Images for illustration only

**Pesos máximos recomendados com carga distribuída
Peso máximo recomendado con la carga distribuida
Recommended maximum weights with evenly distributed.**

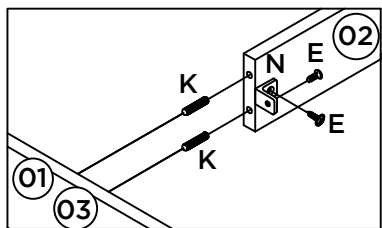
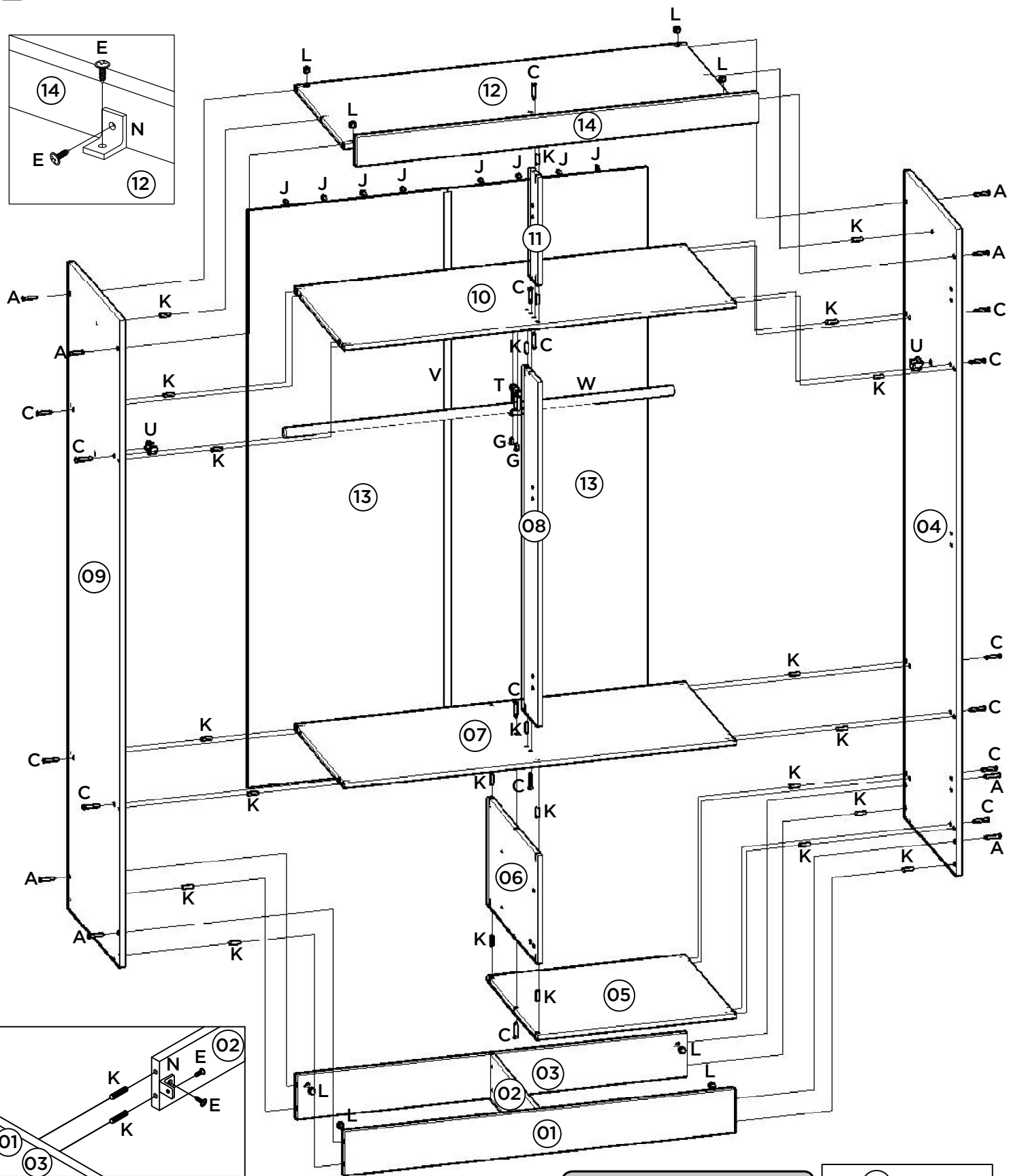
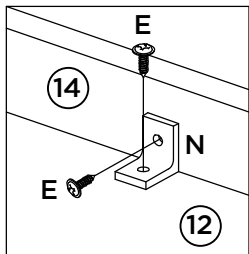

Fixação da cantoneira (N) nos rodapés (01) e (03).

Soporte de fijación (N) los pies (01) y (03).

Angle bracket (N) fixing on footboards (01) and (03).

Fixação da cantoneira (N) na base (05) com os rodapés (01) e (03).

Soporte de fijación (N) la base (05) con los pies (01) y (03).

Angle bracket (N) fixing on the base (05) with the footboards (01) and (03).

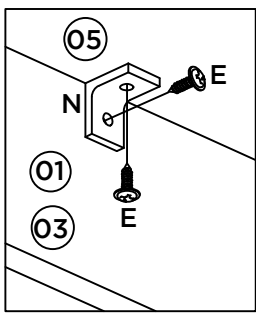

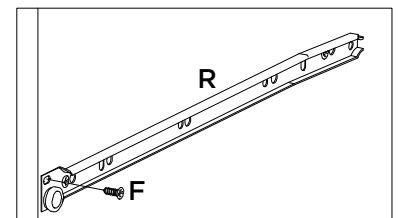
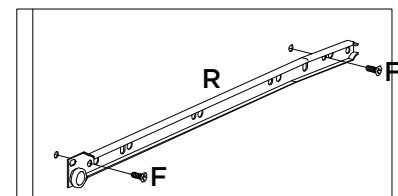
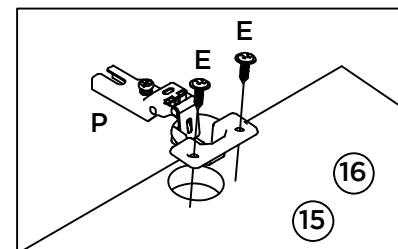
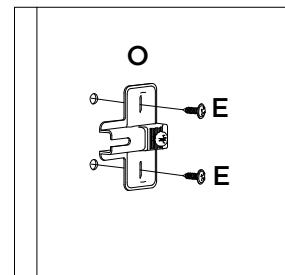
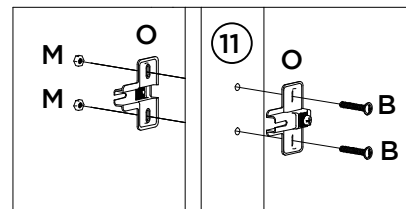
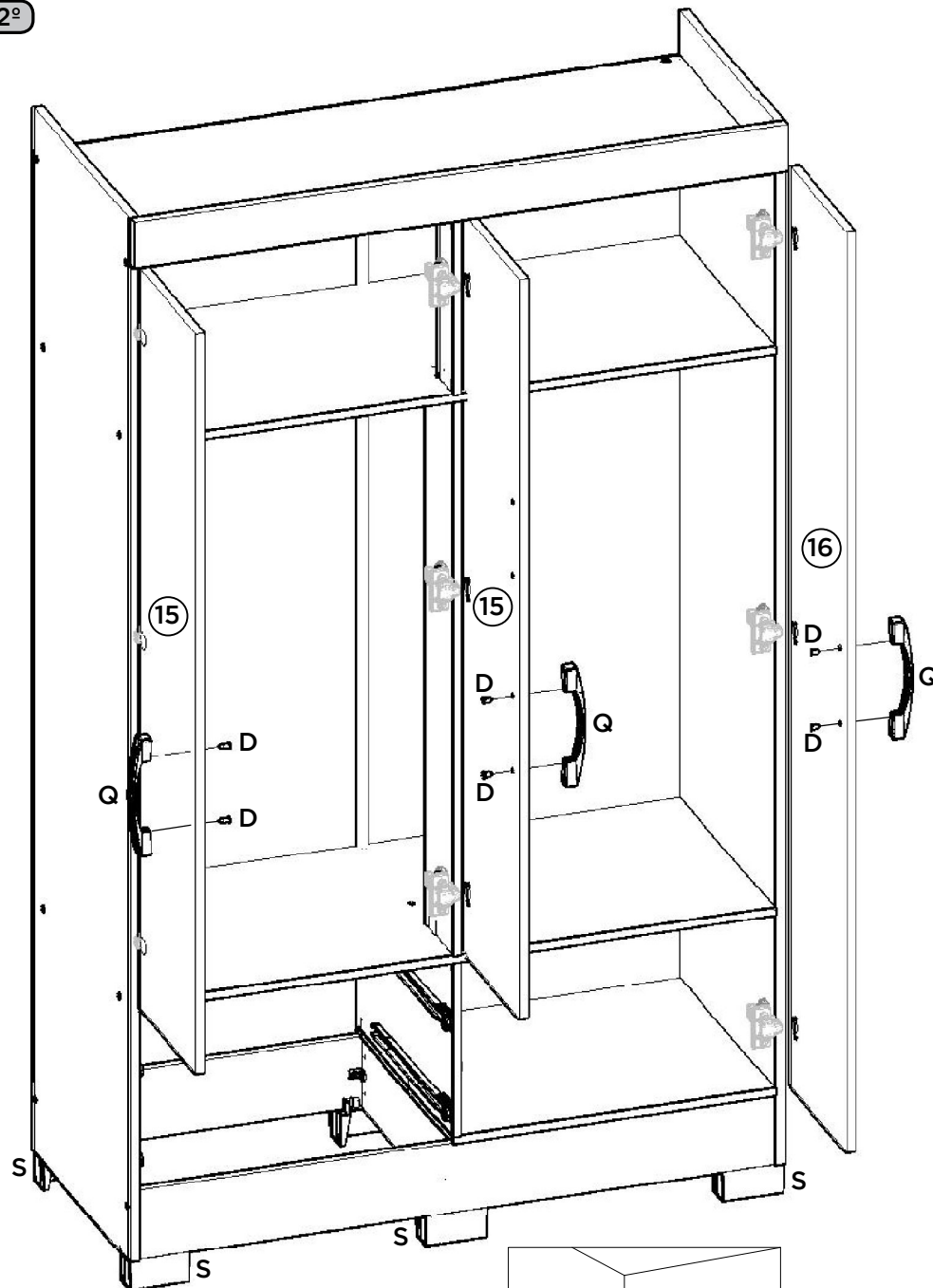

Colocação dos pés "U" (S).

La colocación de los pies "U" (S).

Placement of the "U" feet (S).

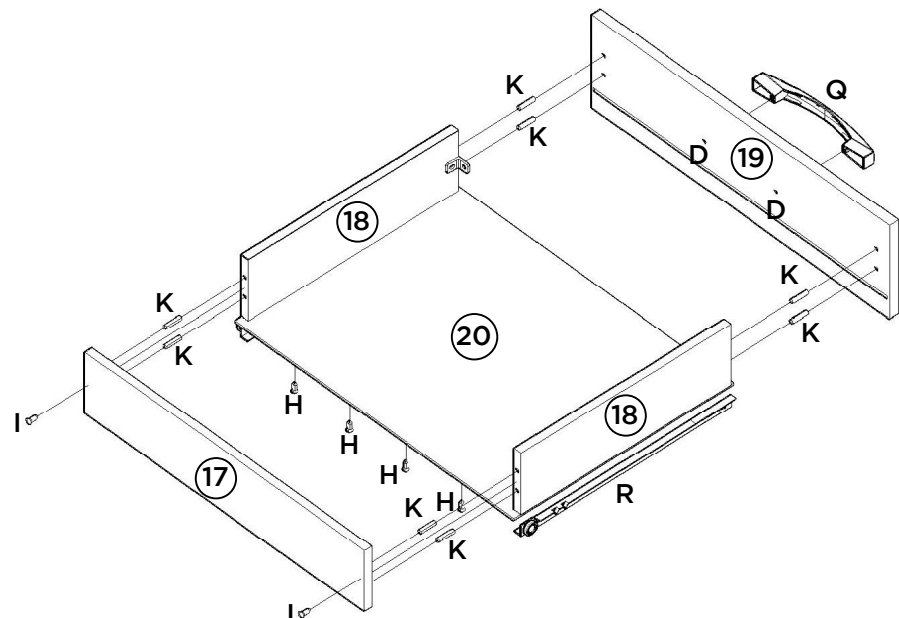
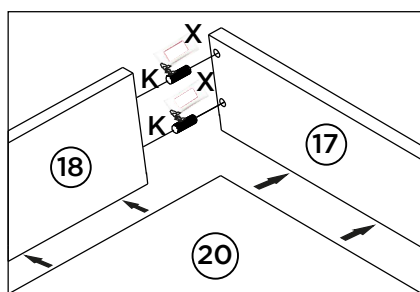
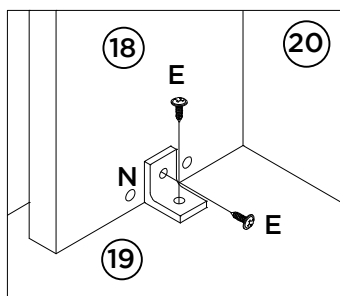
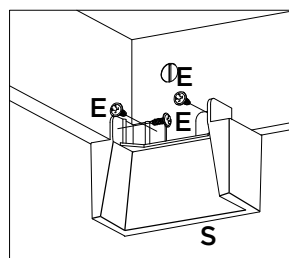

Item	Caixa Caja Box	Qtd Ctd Qty	Descrição Descripción Description	Medidas (mm) Dimensions (mm) Size (measurements) (mm)
01	1/2	01	Rodapé frontal Pie frontal Front footboard	1062x120x12
02	1/2	01	Travessa do rodapé Carril pie Footboard tray	415x120x12
03	1/2	01	Rodapé traseiro Pie trasero Rear footboard	1062x120x12
04	1/2	01	Lateral direita Lateral derecho Right side	1800x445x15
05	1/2	01	Base Base Base	537x445x12
06	1/2	01	Divisão das gavetas División de cajones Drawers division	300x445x12
07	1/2	01	Tampa da cômoda Cubierta aparador Dresser top	1062x445x12
08	1/2	01	Pilastra da porta Puerta Pilastra Door pilaster	956x125x12
09	1/2	01	Lateral esquerda Lateral izquierdo Left side	1800x445x15
10	1/2	01	Chão do maleiro Planta de la taquilla de equipaje Luggage rack floor	1062x445x12
11	1/2	01	Ripa do maleiro Portaequipajes de ripa Luggage rack batten	300x68x12
12	1/2	01	Tampo Cubierta Cover	1062x455x12
13	2/2	02	Fundo Fondo Bottom	1604x542x3
14	1/2	01	Chapéu Sombrero Hat	1090x80x15
15	2/2	02	Porta menor puerta más pequeña Smaller door	1276x265x15
16	2/2	02	Porta Puerta Door	1588x265x15
17	2/2	02	Frente de gaveta Frente de cajón Drawer front	533x152x15
18	1/2	04	Lado de gaveta Lado del cajón Drawer side	350x100x12
19	1/2	02	Ripa de trás Malla detrás Rear batten	500x100x12
20	1/2	02	Fundo de gaveta Fondo del cajón Drawer bottom	499x367x3

FERRAGENS | HERRAJES | HARDWARE

A 08x Parafuso 4,5x50mm CHT. Tornillo 4,5x50mm CHT. Screw 4,5x50mm CHT.	B 02x Parafuso 4,0x22mm FLA. Tornillo 4,0x22mm FLA. Screw 4,0x22mm FLA.	C 16x Parafuso 3,5x40mm CHT. Tornillo 3,5x40mm CHT. Screw 3,5x40mm CHT.	D 12x Parafuso 3,5x25mm FLA. Tornillo 3,5x25mm FLA. Screw 3,5x25mm FLA.	E 84x Parafuso 3,5x12mm FLA. Tornillo 3,5x12mm FLA. Screw 3,5x12mm FLA.	F 12x Parafuso 3,5x12mm CHT. Tornillo 3,5x12mm CHT. Screw 3,5x12mm CHT.	G 02x Parafuso 3,0x20mm FLA. Tornillo 3,0x20mm FLA. Screw 3,0x20mm FLA.	H 16x Parafuso 3,0x16mm CHT. Tornillo 3,0x16mm CHT. Screw 3,0x16mm CHT.	
I 04x Prego 12x12mm Anelado Clavo 12x12mm Anillado Ringed Nails 12x12mm	J 69x Prego 10x10mm Clavo 10x10mm Nail 10x10mm	K 44x Cavilha 5x25mm Cinta 5x25mm Dowel 5x25mm	L 08x Porca cilíndrica Tuerca cilíndrica Cylindrical nut	M 02x Porca Sextavada Tuerca Hexagonal Hexagon Nut	N 11x Cantoneira plástica Cantonera plástica Plastic angle brackets	O 12x Calço metal 5mm Calzado metálico 5mm 5mm metal shim	P 12x Dobradiça metal 26mm Bisagra de metal 26mm 26mm metal hinge	
Q 06x Puxador Indonésia 128mm Tirador Indonésia 128mm 128mm Indonésia Handle	R 02x Corrediça metal 350mm Corredera de metal 350mm Sliding metal 350mm	S 06x Pé "U" 50x40x100mm Pie "U" 50x40x100mm 50x40x100mm "U" feet	T 01x Suporte cabideiro "U" Soporte de percha "U" "U" Coat hanger support	U 02x Suporte cabideiro Soporte de percha Coat hanger support	V 01x Perfil "I" 1589mm Perfil "I" 1589mm Profile "I" 1589mm	W 01x Cabideiro Madeira 1056mm Cabezal Madera 1056mm 1056mm wooden hanger	X 01x Sachê de cola Bolsa de pegamento Glue bag	
Y 24x Adesivo tapa parafuso 10mm Adhesivo tapón de tornillo 10mm Bolt cover adhesive 10mm	Z 01x Etiqueta resinada Briz Etiqueta resinada Briz Briz resin label							

AVISO

Para limpeza de seu móvel, use uma flanela seca ou umedecida, e não utilize produtos químicos que possam danificar seu produto.

SISTEMA DE MONTAGEM

O sistema de montagem dos produtos, funciona de acordo com a ordem crescente dos números indicados no desenho. Ex: 01, 02, 03, 04... até a conclusão da montagem.

ADVERTENCIA

Para limpieza de su móvil, use una franela seca o húmeda, y no utilice productos químicos que puedan dañar su producto.

SISTEMA DE MONTAJE

El sistema de montaje de los productos funciona de acuerdo con el orden creciente de los números indicados en el dibujo. Ej.: 01, 02, 03, 04... hasta la conclusión del montaje.

NOTICE

To clean your furniture, use a dry or wet cloth, and do not use chemicals that may damage your product.

ASSEMBLY SYSTEM

The products' assembly system works according to the increasing order of the indicated numbers. For example: 01, 02, 03, 04 ... to the end of the assembly.