



# LISTA DE PEÇAS

LISTA DE PIEZAS / PARTS LIST

ITEM Artículo / Article	DESCRIÇÃO Descripción / Description	QUANTIDADE Cantidad / Amount
A	 1/4x50 mm	4
B	 Chave Zeta	1

ITEM Artículo / Article	DESCRIÇÃO Descripción / Description	QUANTIDADE Cantidad / Amount
1	Apoio	1
2	Pés	2

# 1 PASSO

Paso  
Step

Ferramentas  
Herramientas / Tools

B — 

Peças  
Piezas / Tools

A — 

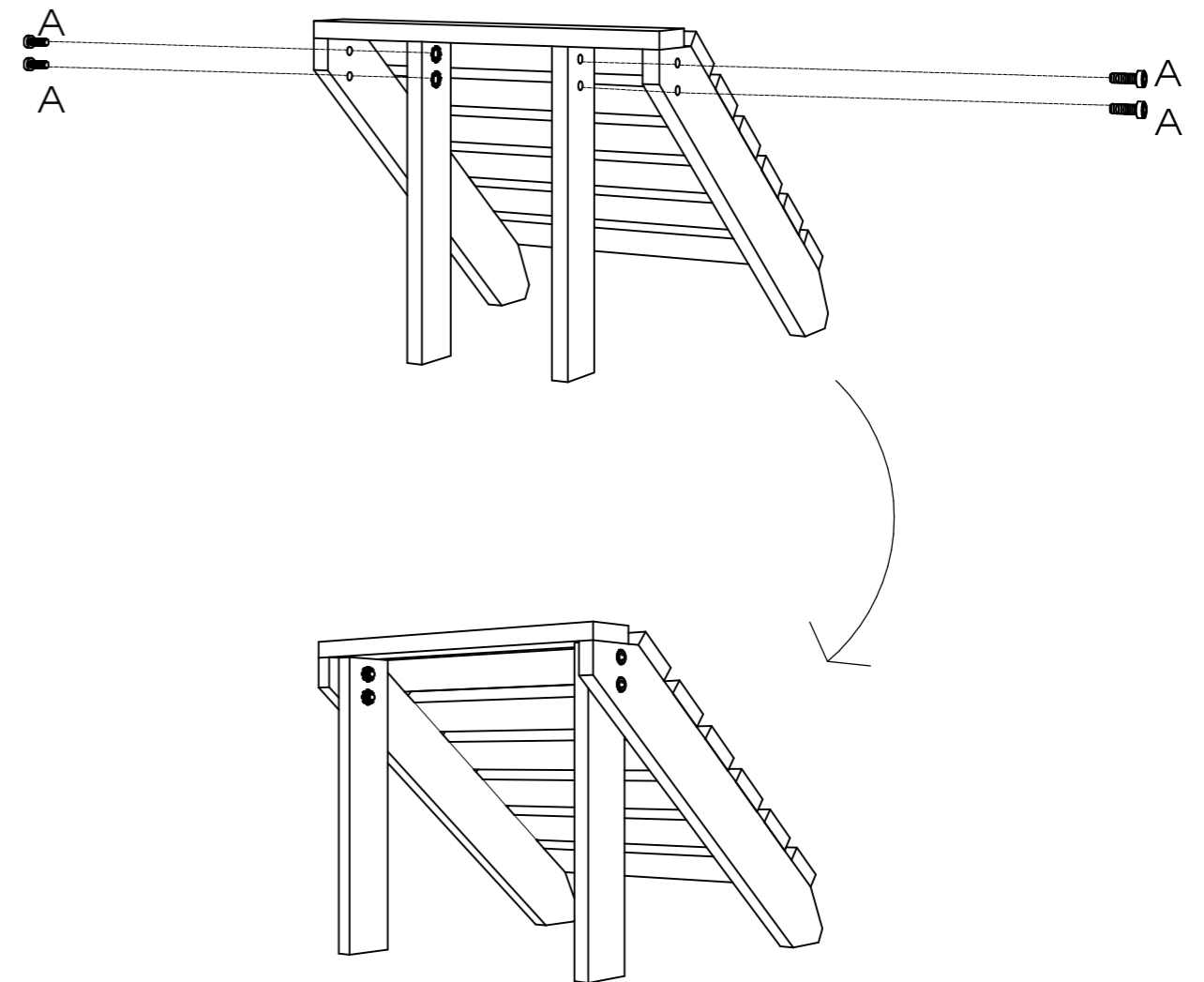

# PRONTO! Seu APOIO está montado.

Listo! Su producto está ensamblado.

Ready! Your product is assembled.

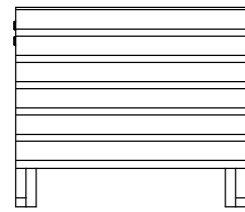

**VISTA FRONTAL**  
Frontal / Front

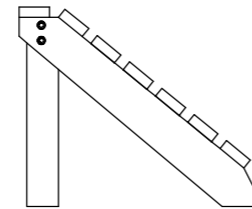

**VISTA LATERAL**  
Lado / Side

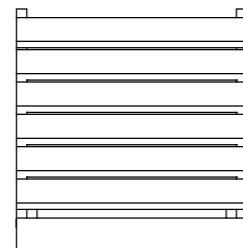

**VISTA SUPERIOR**  
Más alto/ Higher

**PRODUTO FABRICADO NO BRASIL.**

Producto hecho en Brasil  
Product made in Brazil

# MANUAL DE MONTAGEM

Manual del producto. / User's Guide.

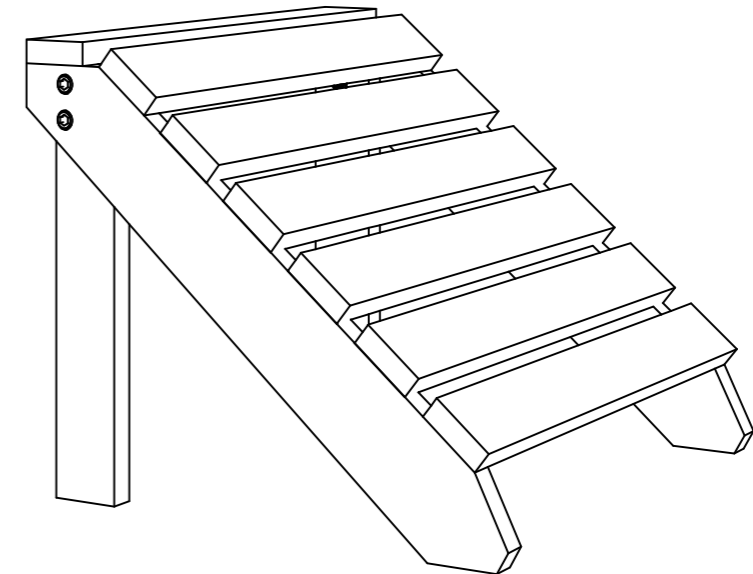

## APOIO



Montagem 02 pessoas  
Asamblea 02 personas  
Assembly 02 people



Tempo: 20 minutos  
Tiempo: 20 minutos  
Time: 20 minutes

## IMPORTANTE

Importante / Important







- 1- Monte todos os itens com atenção.
- 2- Monte seu produto em uma superfície limpa e plana. Para não danificar seu produto, aconselhamos utilizar a embalagem ou um tapete para forrar o chão.
- 3- Aperte bem os parafusos.
- 4- Verifique periodicamente para que as partes não estejam soltas. Nestes casos precisam ser reapertados.

- 1- Reúna todos los artículos cuidadosamente.
- 2- Monte su producto sobre una superficie limpia y plana. Para no dañar su producto, le recomendamos que utilice el embalaje o una alfombrilla.
- 3- Ajuste los tornillos.
- 4- Revise periódicamente para comprobar no son puestos en libertad. En estos casos hay que volver a apretar.

- 1- Assemble all items carefully.
- 2- Mount your product on a clean, flat surface. In order not to damage your product, we advise you to use the packaging or a floor mat.
- 3- Tighten well the screws.
- 4- Check periodically so that the parts are not loose. In these cases they need to be retightened.

# LISTA DE PEÇAS

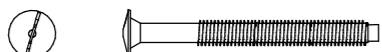
LISTA DE PIEZAS / PARTS LIST

ITEM Artículo / Article	DESCRIÇÃO Descripción / Description	QUANTIDADE Cantidad / Amount
A	 1/4x60 mm	4
B	 Polca Cilíndrica	2
C	 4x35mm	4
D	 1/4x50 mm	2
E	 1/4x70 mm	2
F	 Chave Zeta	1

ITEM Artículo / Article	DESCRIÇÃO Descripción / Description	QUANTIDADE Cantidad / Amount
1	Assento	1
2	Encosto	1
3	Pés	2
4	Braço	2

## 1 PASSO Paso Step

Ferramentas  
Herramientas / Tools

F — 

Peças  
Piezas / Tools

A — 

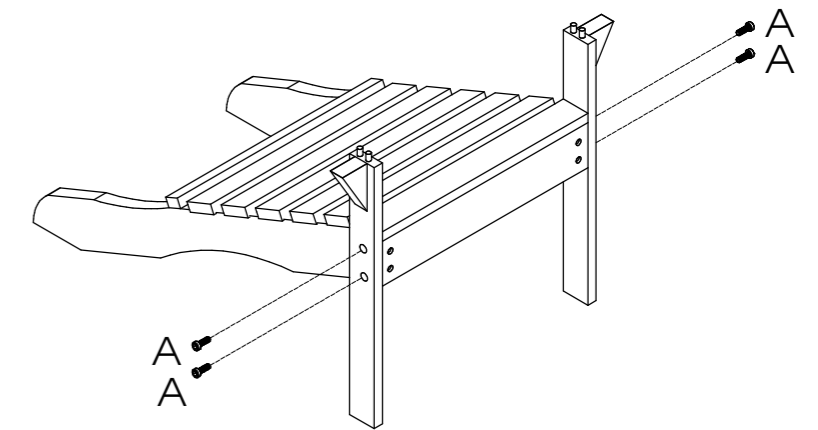

## 2 PASSO Paso Step

Peças  
Piezas / Tools

C — 

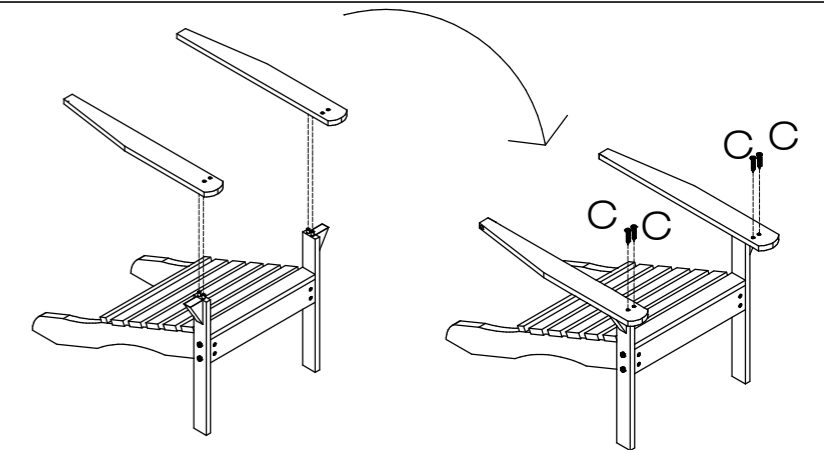

## 3 PASSO Paso Step

Peças  
Piezas / Tools

D — 

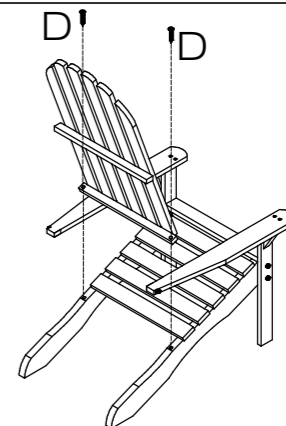

## 4 PASSO Paso Step

Peças  
Piezas / Tools

E — 

B — 

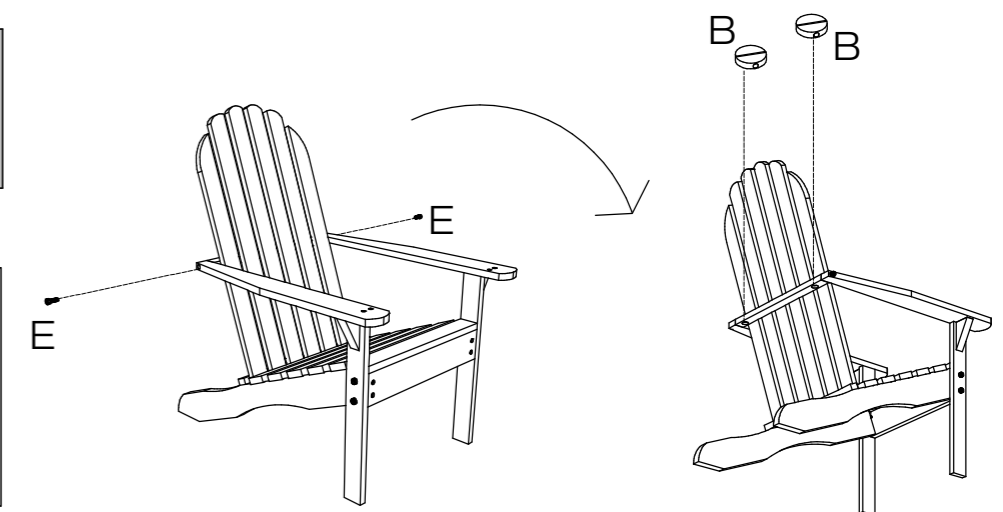

# PRONTO! Sua CADEIRA está montada.

Listo! Su producto está ensamblado.

Ready! Your product is assembled.

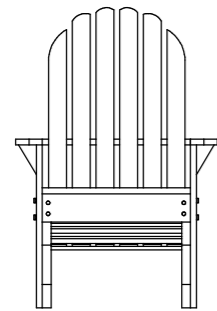

**VISTA FRONTAL**  
Frontal / Front

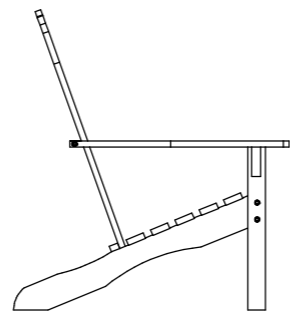

**VISTA LATERAL**  
Lado / Side

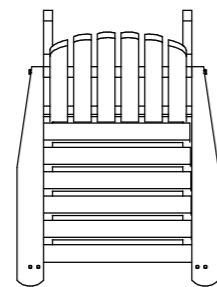

**VISTA SUPERIOR**  
Más alto/ Higher

**PRODUTO FABRICADO NO BRASIL.**

Producto hecho en Brasil  
Product made in Brazil

# MANUAL DE MONTAGEM

Manual del producto. / User's Guide.

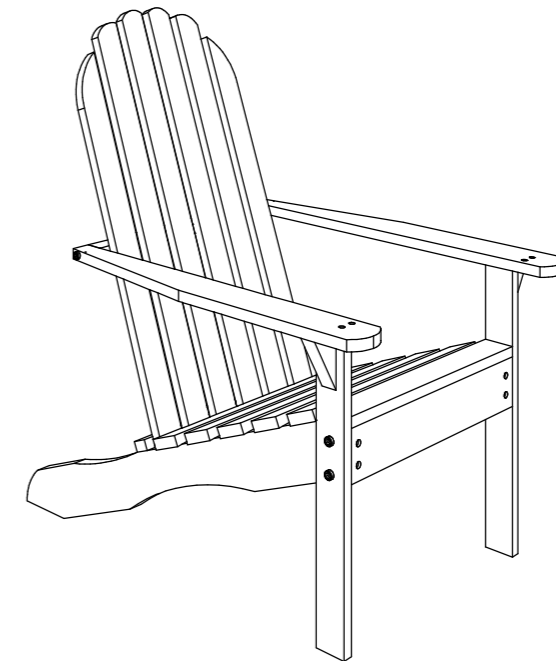

## CADEIRA

Ref. 045



Montagem 02 pessoas  
Asamblea 02 personas  
Assembly 02 people



Tempo: 20 minutos  
Tiempo: 20 minutos  
Time: 20 minutes

## IMPORTANTE

Importante / Important

- 1- Monte todos os itens com atenção.
- 2- Monte seu produto em uma superfície limpa e plana. Para não danificar seu produto, aconselhamos utilizar a embalagem ou um tapete para forrar o chão.
- 3- Aperte bem os parafusos.
- 4- Verifique periodicamente para que as partes não estejam soltas. Nestes casos precisam ser reapertados.

- 1- Reúna todos los artículos cuidadosamente.
- 2- Monte su producto sobre una superficie limpia y plana. Para no dañar su producto, le recomendamos que utilice el embalaje o una alfombra.
- 3- Ajuste los tornillos.
- 4- Revise periódicamente para comprobar no son puestos en libertad. En estos casos hay que volver a apretar.

- 1- Assemble all items carefully.
- 2- Mount your product on a clean, flat surface. In order not to damage your product, we advise you to use the packaging or a floor mat.
- 3- Tighten well the screws.
- 4- Check periodically so that the parts are not loose. In these cases they need to be retightened.