

ATENÇÃO- LIMPEZA E CONSERVAÇÃO / ATTENTION - CLEANING AND CONSERVATION

A limpeza do móvel deve ser feita somente com pano. Não utilizar produtos abrasivos ou similares como: Cera, álcool, detergentes, tinner, lustra móveis.
 Cleaning the furniture must only be done with a cloth. Do not use abrasive or similar products such as: Wax, alcohol, detergents, tinner, furniture polish.

GARANTIA 90 DIAS / 90 DAY WARRANTY

Avárias ocasionadas na montagem do produto não se enquadram na garantia. Para solicitar componentes utilize o código identificador.
 Faults caused during product assembly are not covered by the warranty. To request components, use the identifier code.

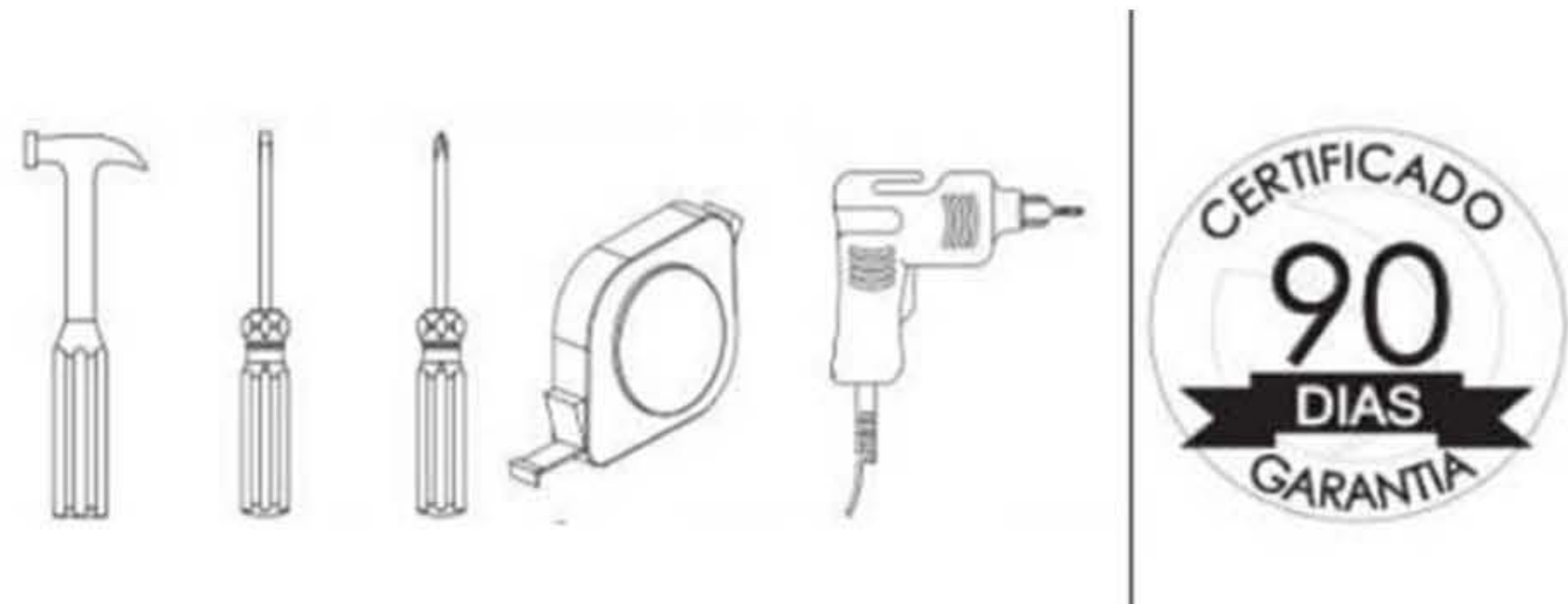

ROUPEIRO LISBOA 6 PORTAS

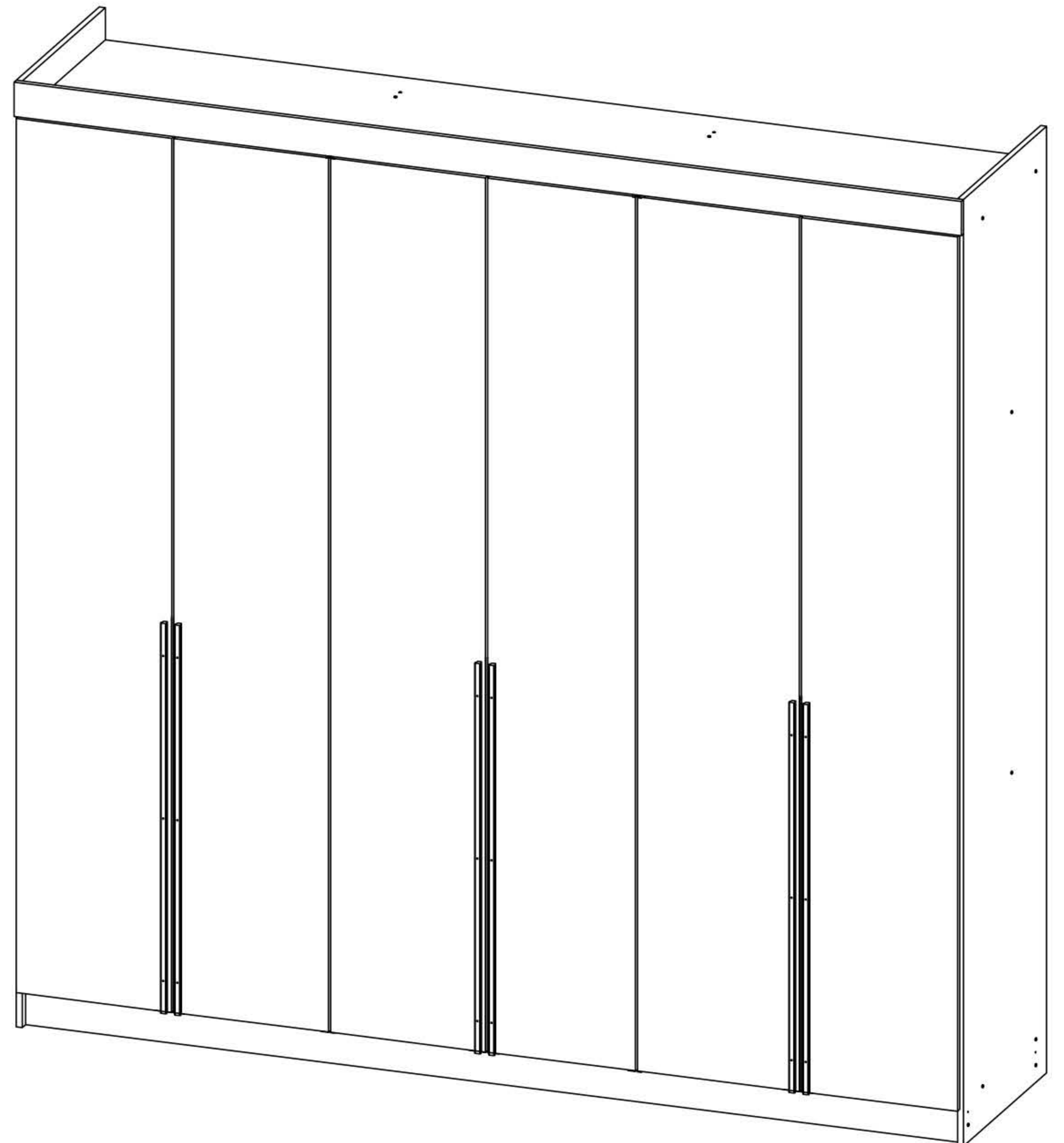

LISTA DE ACESSORIOS / LIST OF ACCESSORIES

Nº	DESCRIÇÃO	DESCRIPTION_EN	QTD
A	PARAFUSO 3,5 X 35	SCREW 3.5 X 35	16
B	PARAFUSO 3,5 X 40	SCREW 3.5 X 40	61
C	PARAFUSO 3,5 X 16	SCREW 3.5 X 16	180
D	CANTONEIRA 13 X 13	CORNER BOARD 13 X 13	12
E	PARAFUSO FIX	SCREW FIX	14
F	CAVILHA 6 X 30	DOWEL 6 X 30	70
G	CABIDEIRO 66,5	HANGER 66.5	2
H	PONTEIRA DE CABIDEIRO	HANGER TIP	4
I	PUXADOR 1M	HANDLE 1M	6
J	PARAFUSO 3,5 X 25 FLANGE	SCREW 3.5 X 25 FLANGE	18
K	DOBRADIÇA NORMAL	NORMAL HINGE	24
L	PREGO 10 X 10	NAIL 10 X 10	135
M	PAR DE CORREDIÇA	PAIR OF SLIDES	6
N	SAPATA BRANCA	WHITE SHOES	10
O	TAMBOR	DRUM	14
P	PERFIL DO FUNDO	FUND PROFILE	3

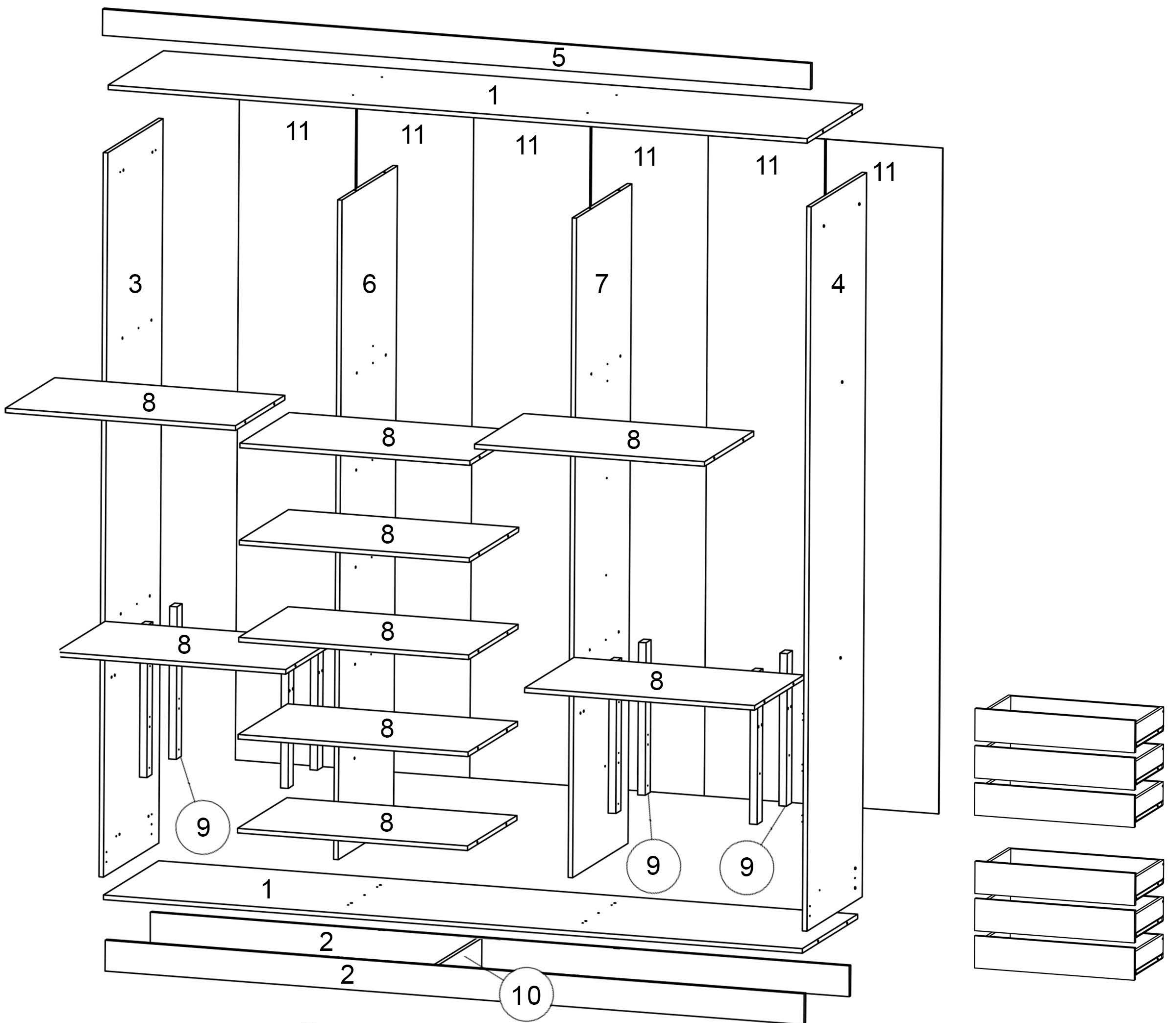

DESCRIÇÃO DE PEÇAS / DESCRIPTION OF PARTS

Nº	DESCRIÇÃO	DESCRIPTION_EN	QTD
1	BASE INFERIOR	LOWER BASE	2
2	RODAPÉ	BASEBOARD	2
3	LATERAL ESQUERDA	LEFT SIDE	1
4	LATERAL DIREITA	RIGHT SIDE	1
5	ESPELHO	MIRROR	1
6	LATERAL DIVISÓRIA ESQUERDA	LEFT PARTITION SIDE	1
7	LATERAL DIVISÓRIA DIREITA	RIGHT PARTITION SIDE	1
8	PRATELEIRA	SHELF	9
9	BATENTE	FLAP	8
10	REFORÇO INFEIOR DA BASE	LOWER BASE REINFORCEMENT	1
11	FUNDO 3MM	3MM BACKGROUND	6
12	PORTAS ROUPEIROS	WARDROBE DOORS	6
13	FRENTE GAVETA	DRAWER FRONT	6
14	LATERAL GAVETA DIREITA	RIGHT DRAWER SIDE	6
15	LATERAL GAVETA ESQUERDA	LEFT DRAWER SIDE	6
16	TRASEIRA DA GAVETA	REAR OF DRAWER	6
17	FUNDO 3MM GAVETA	3MM DRAWER BOTTOM	6

PASSO 1 / STEP 1

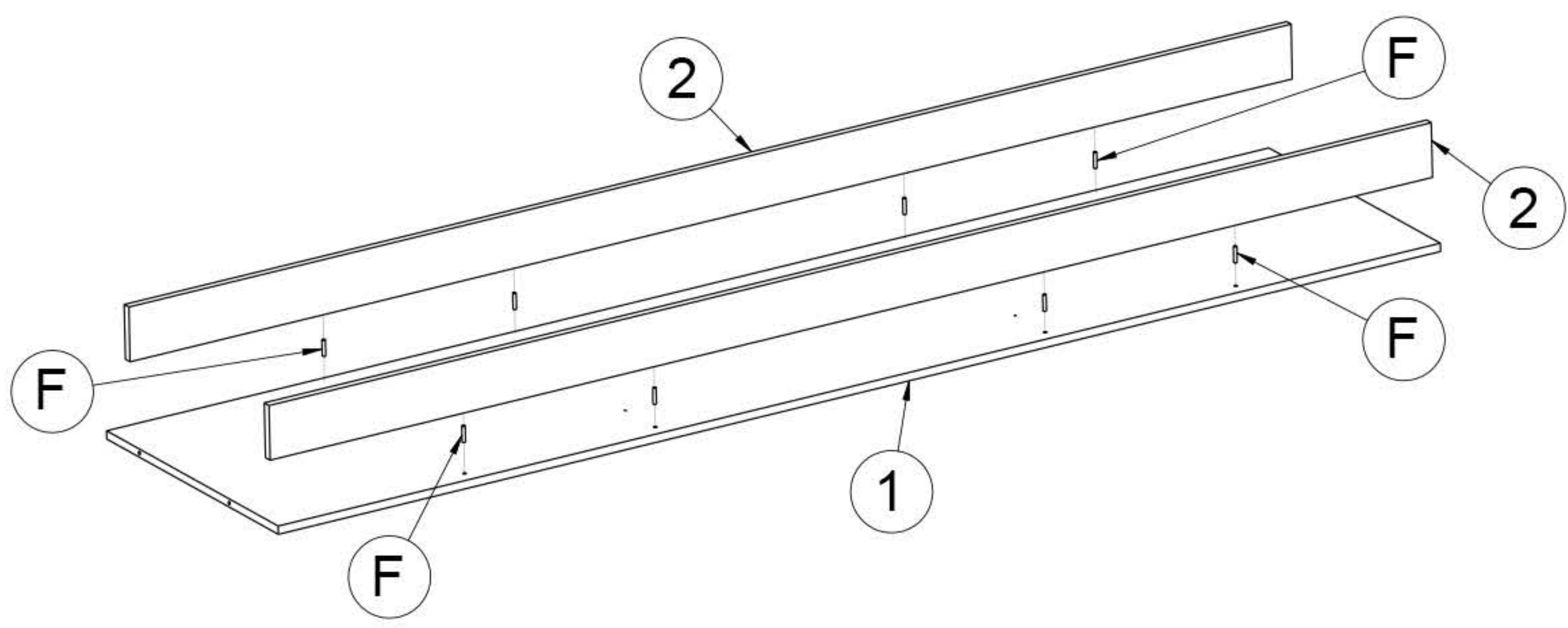

PASSO 2 / STEP 2

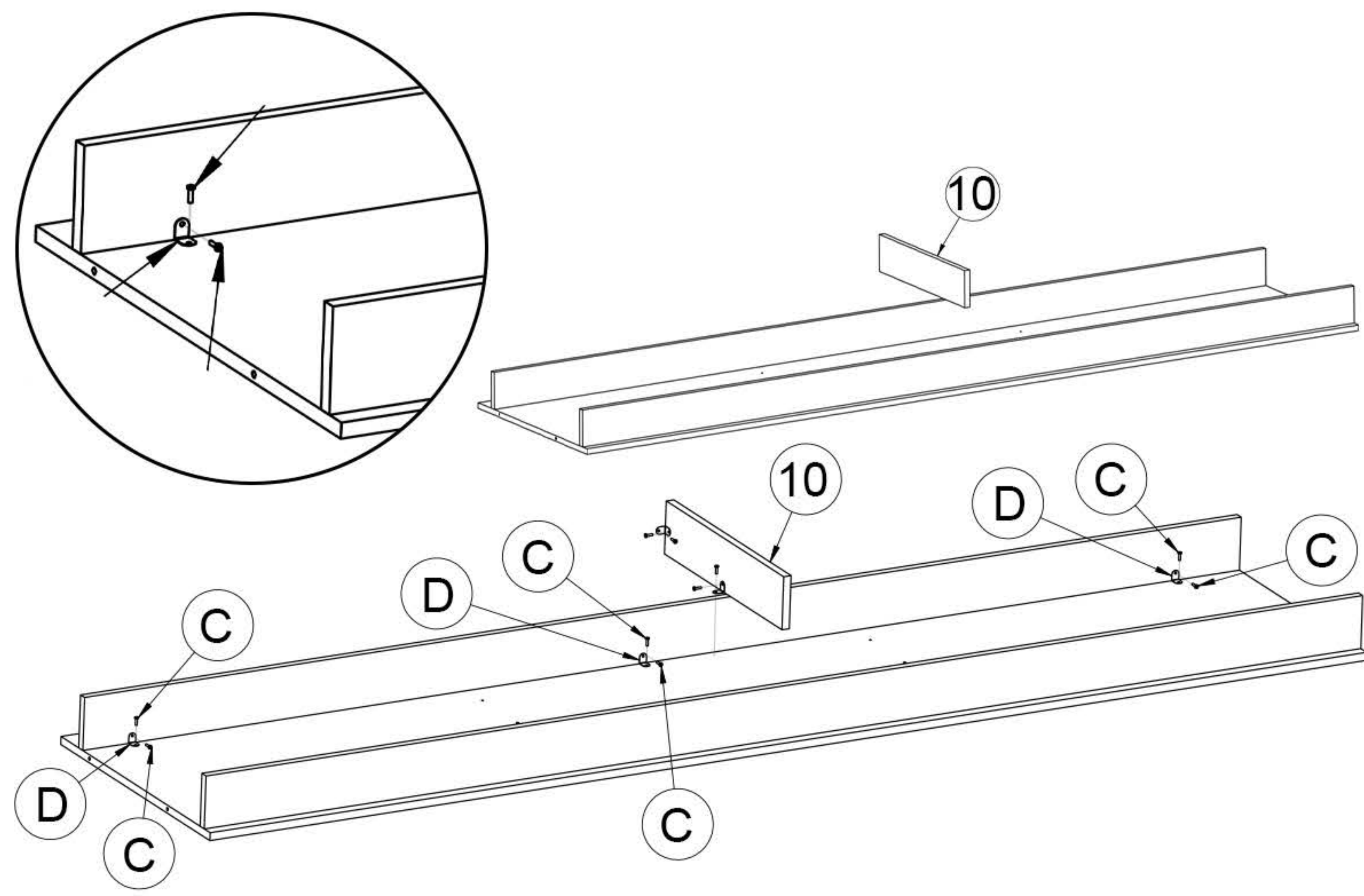

PASSO 3 / STEP 3

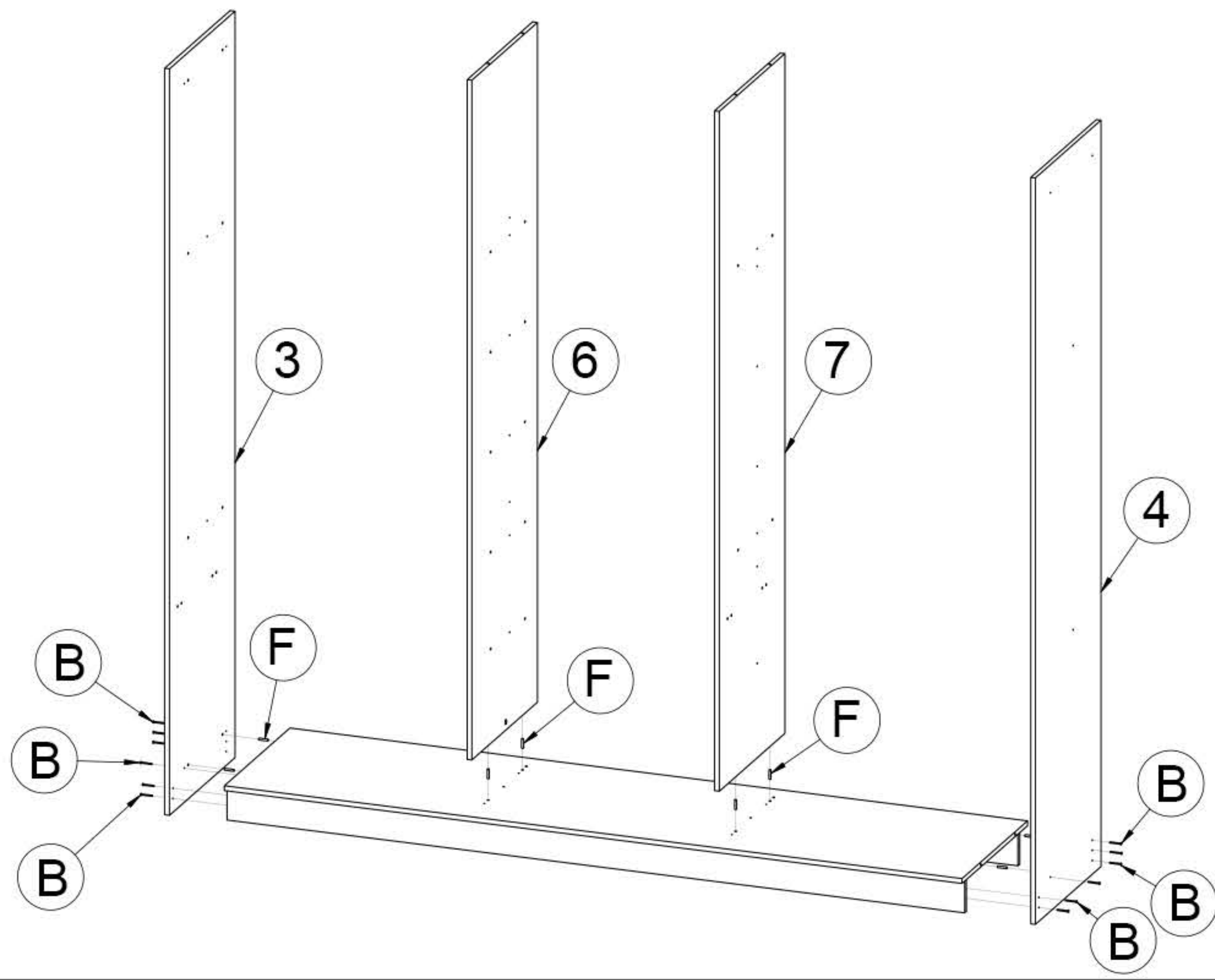

PASSO 4 / STEP 4

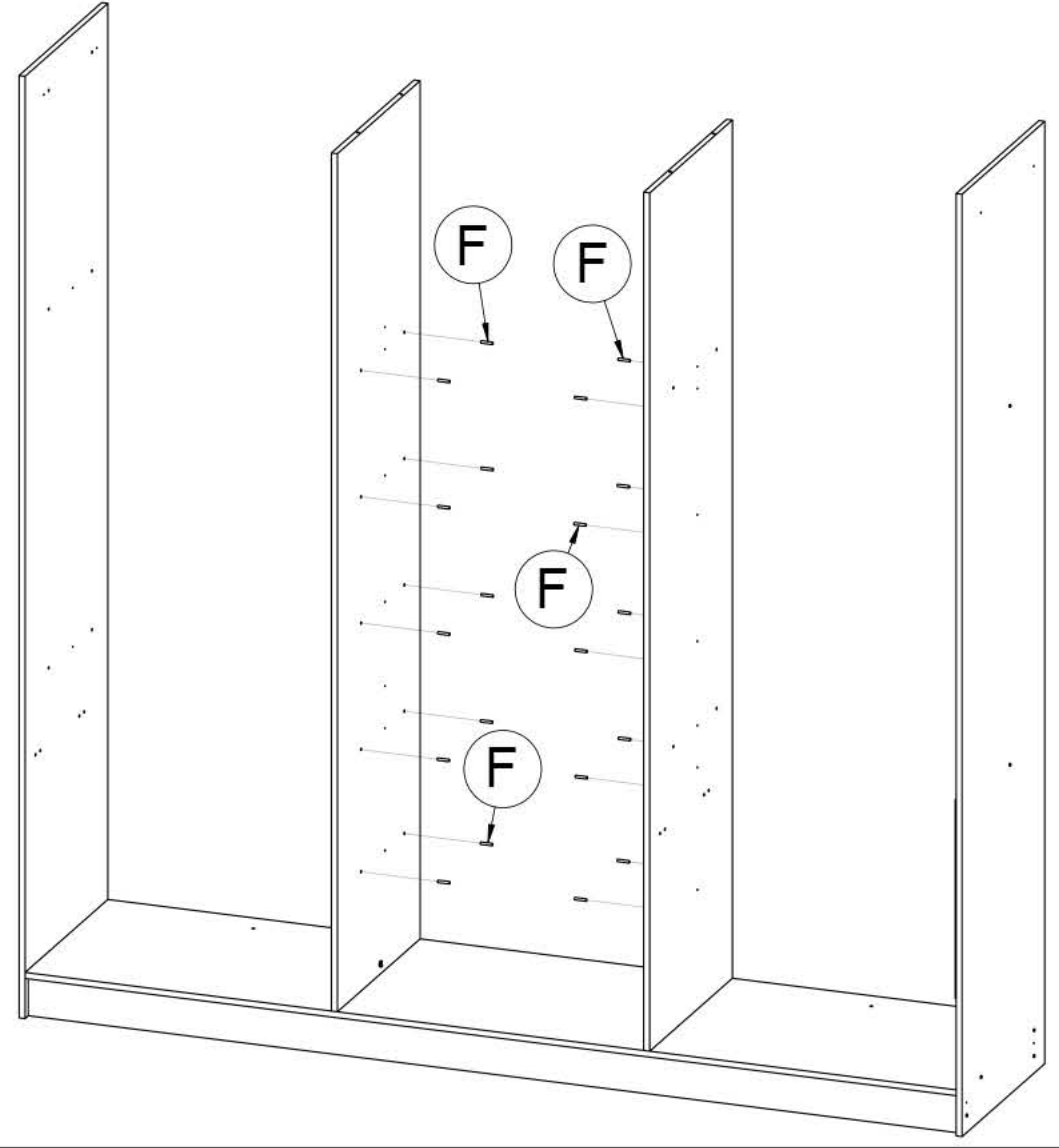

PASSO 5 / STEP 5

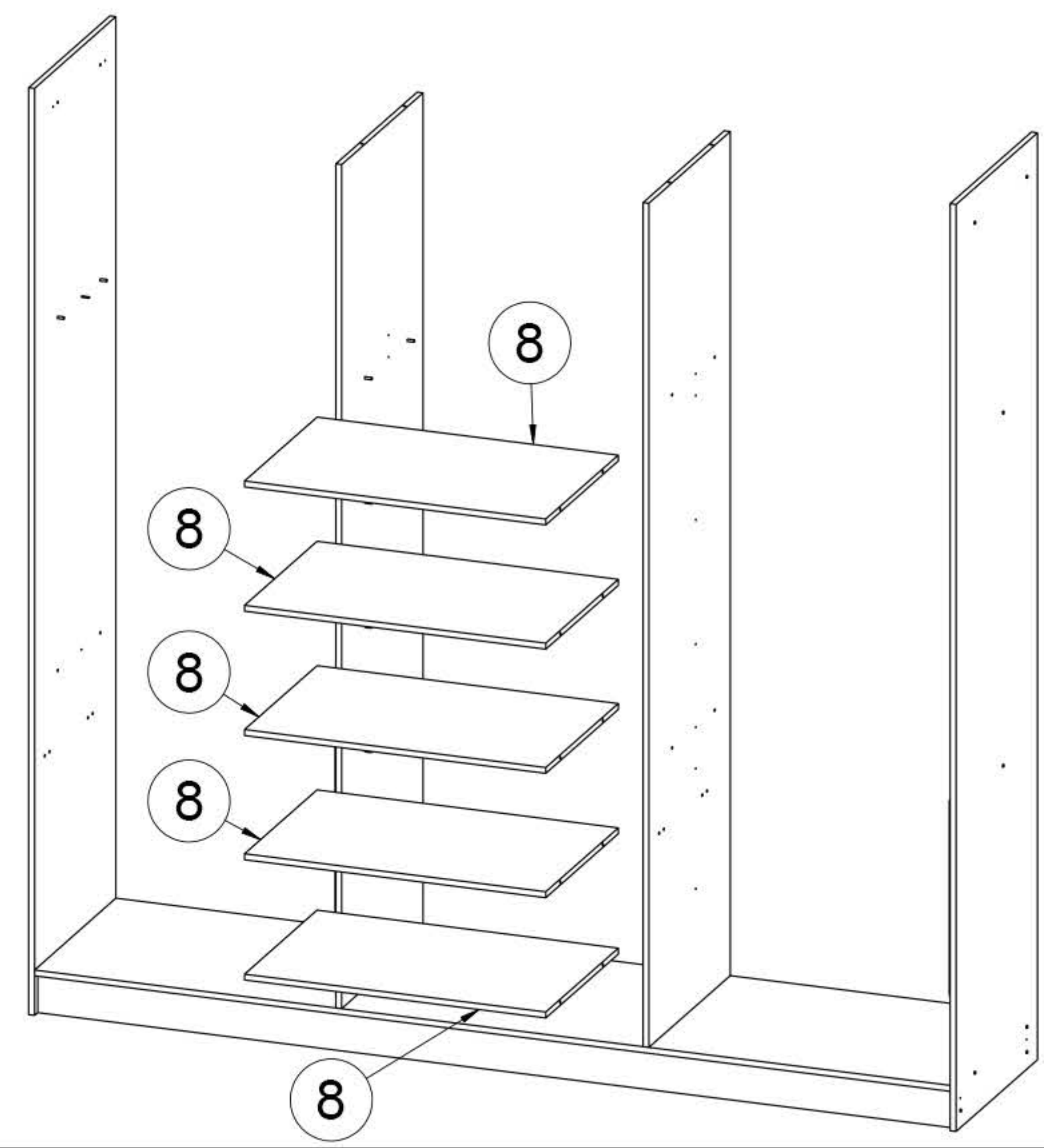

PASSO 6 / STEP 6

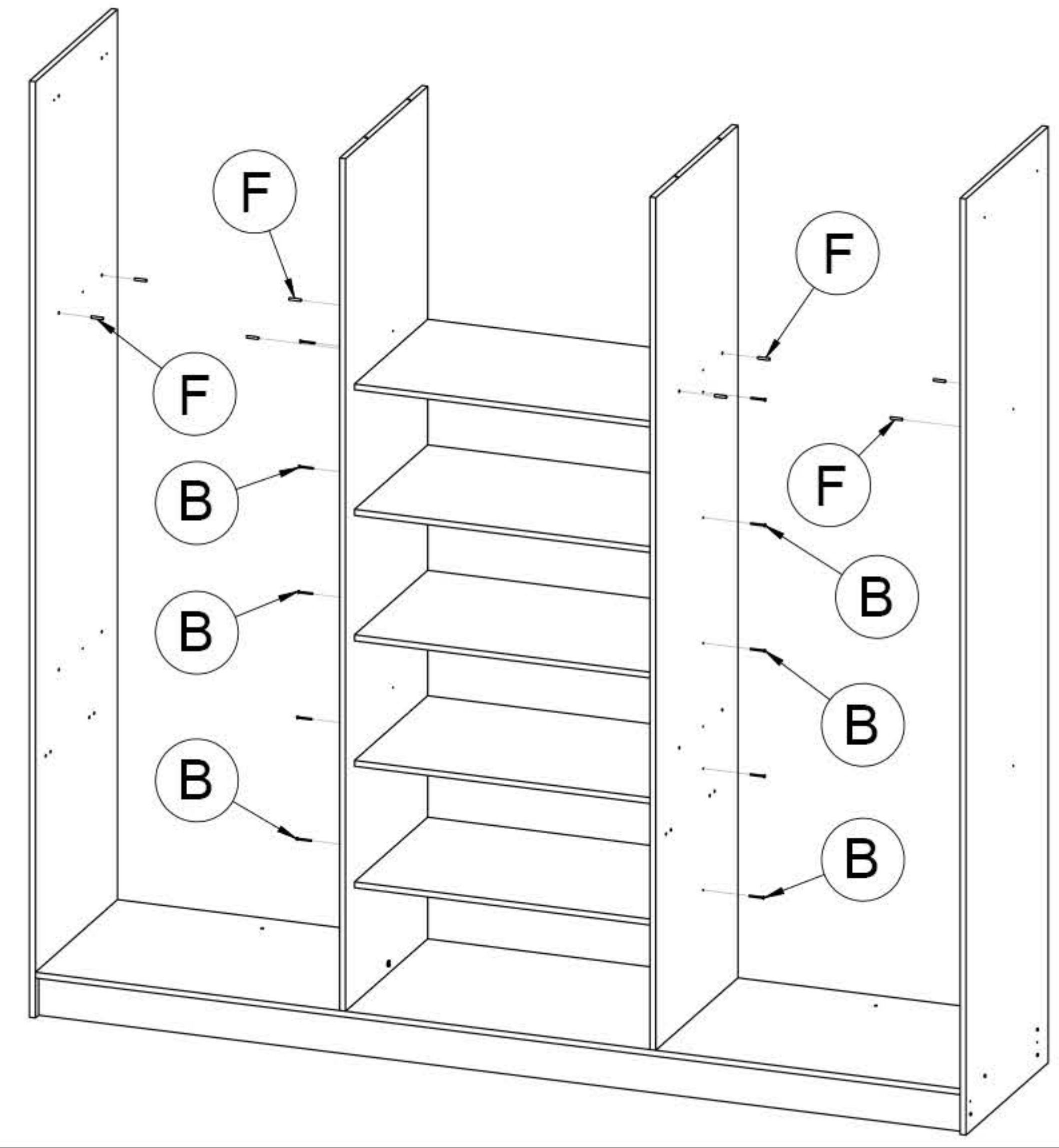

PASSO 7 / STEP 7

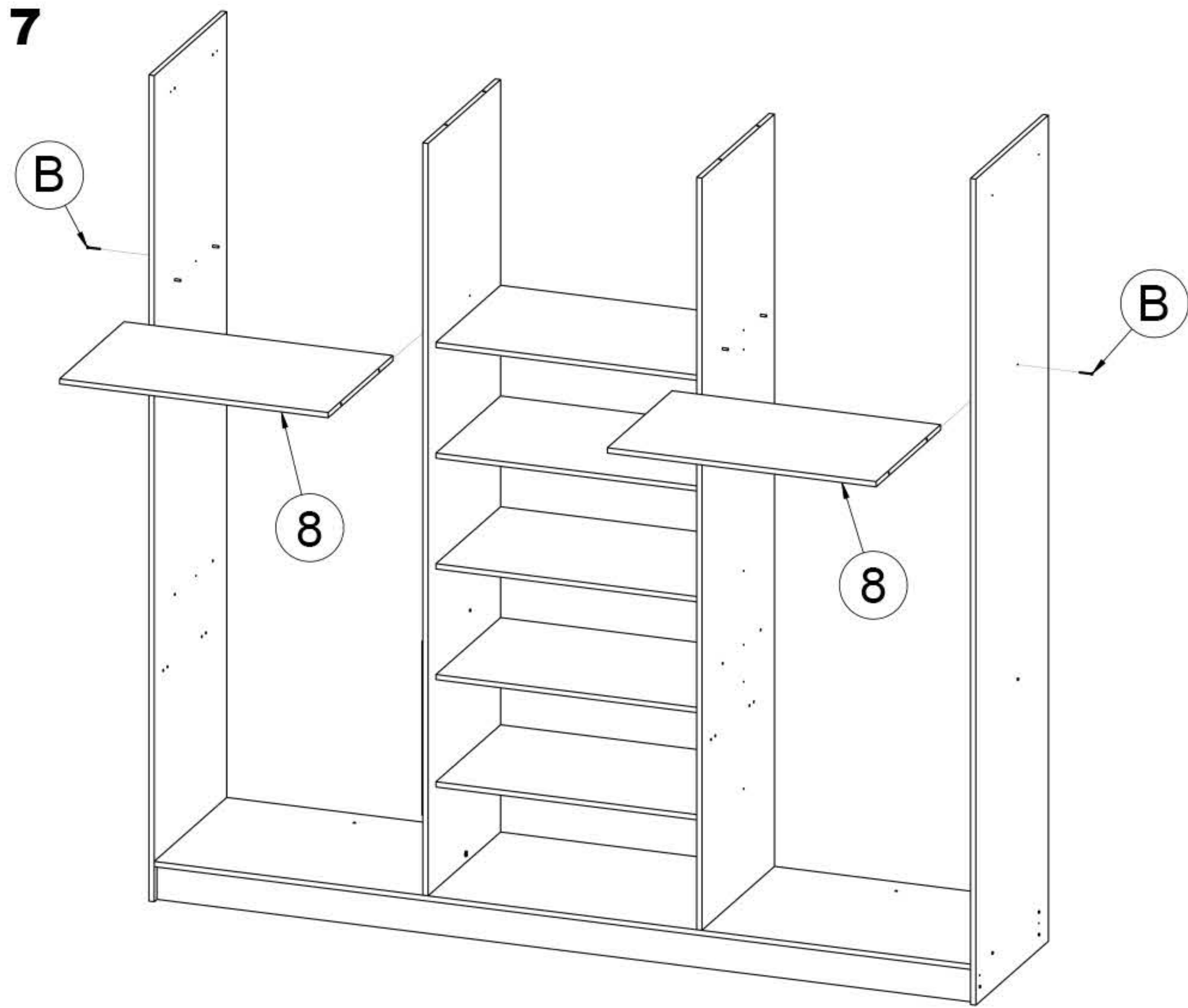

PASSO 8 / STEP 8

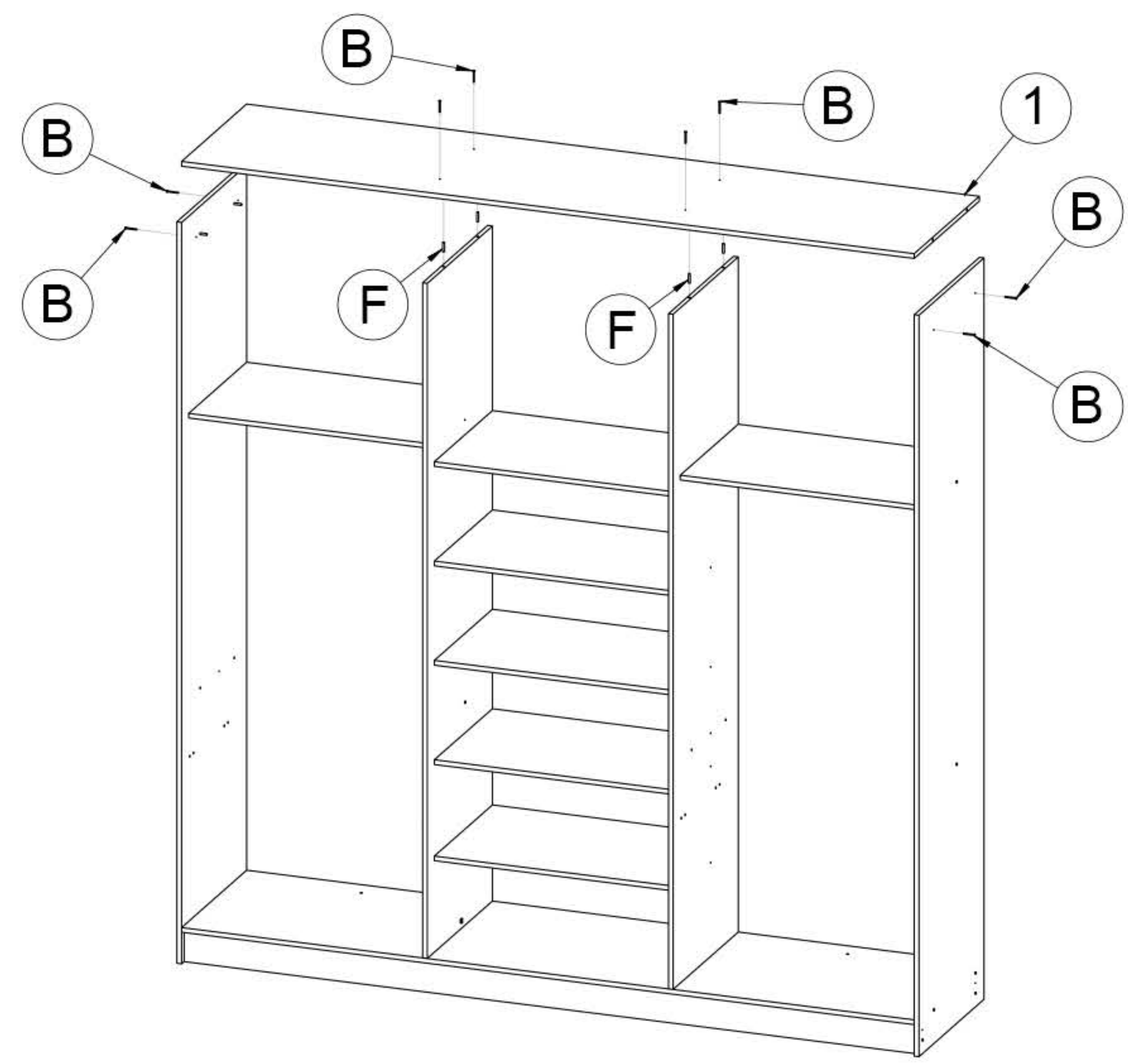

**PASSO 9
STEP 9**

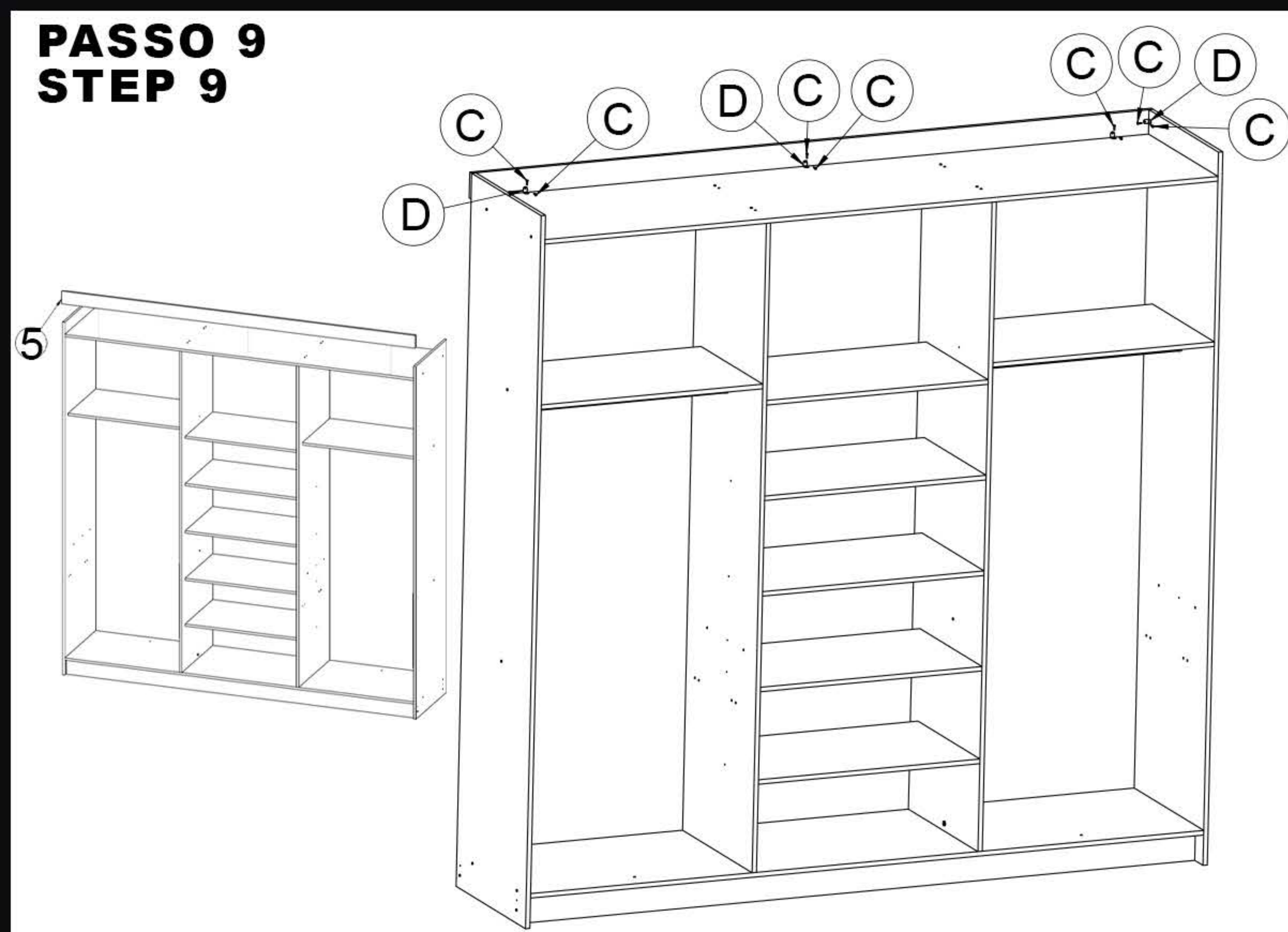

**PASSO 10
STEP 10**

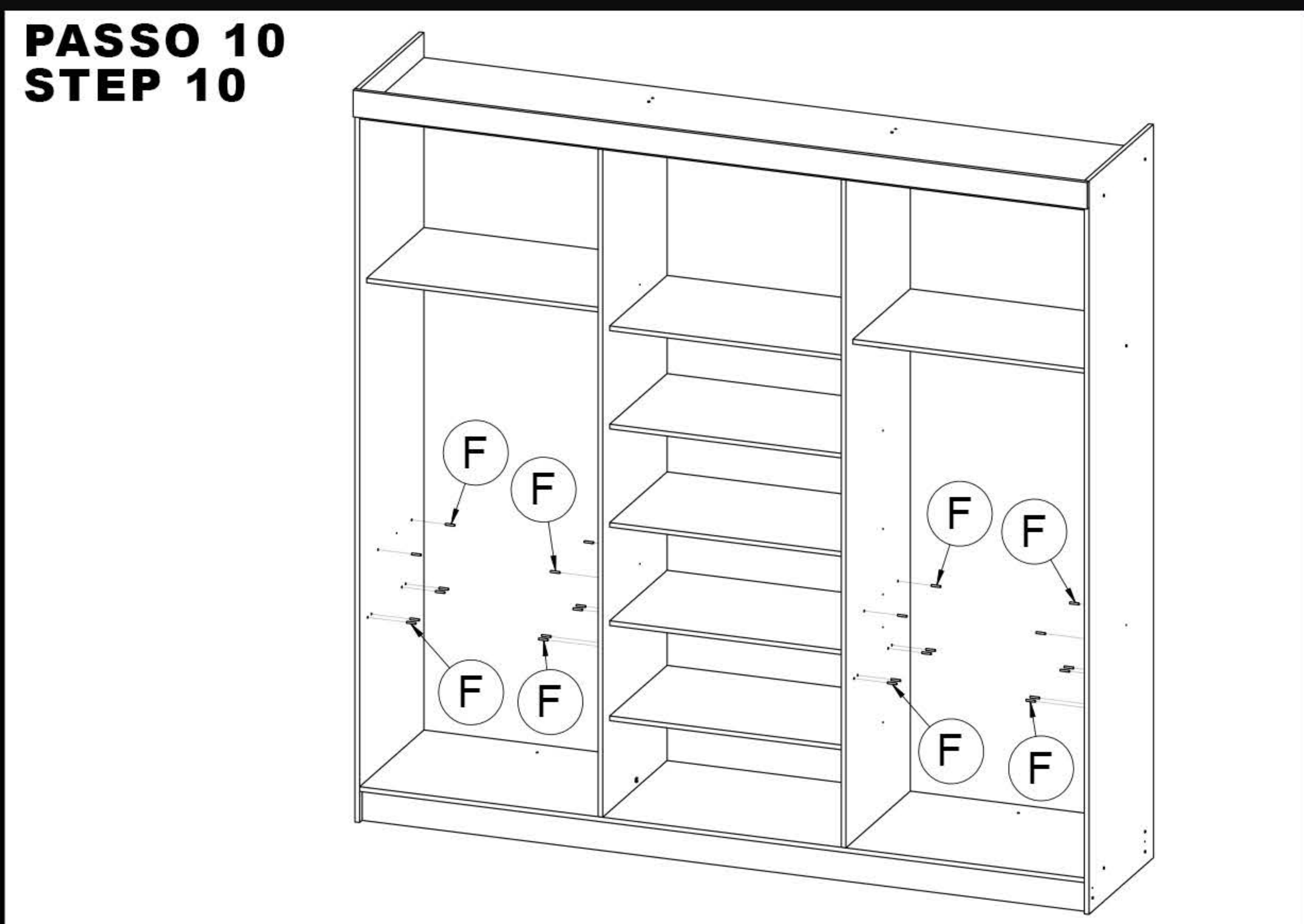

**PASSO 11
STEP 11**

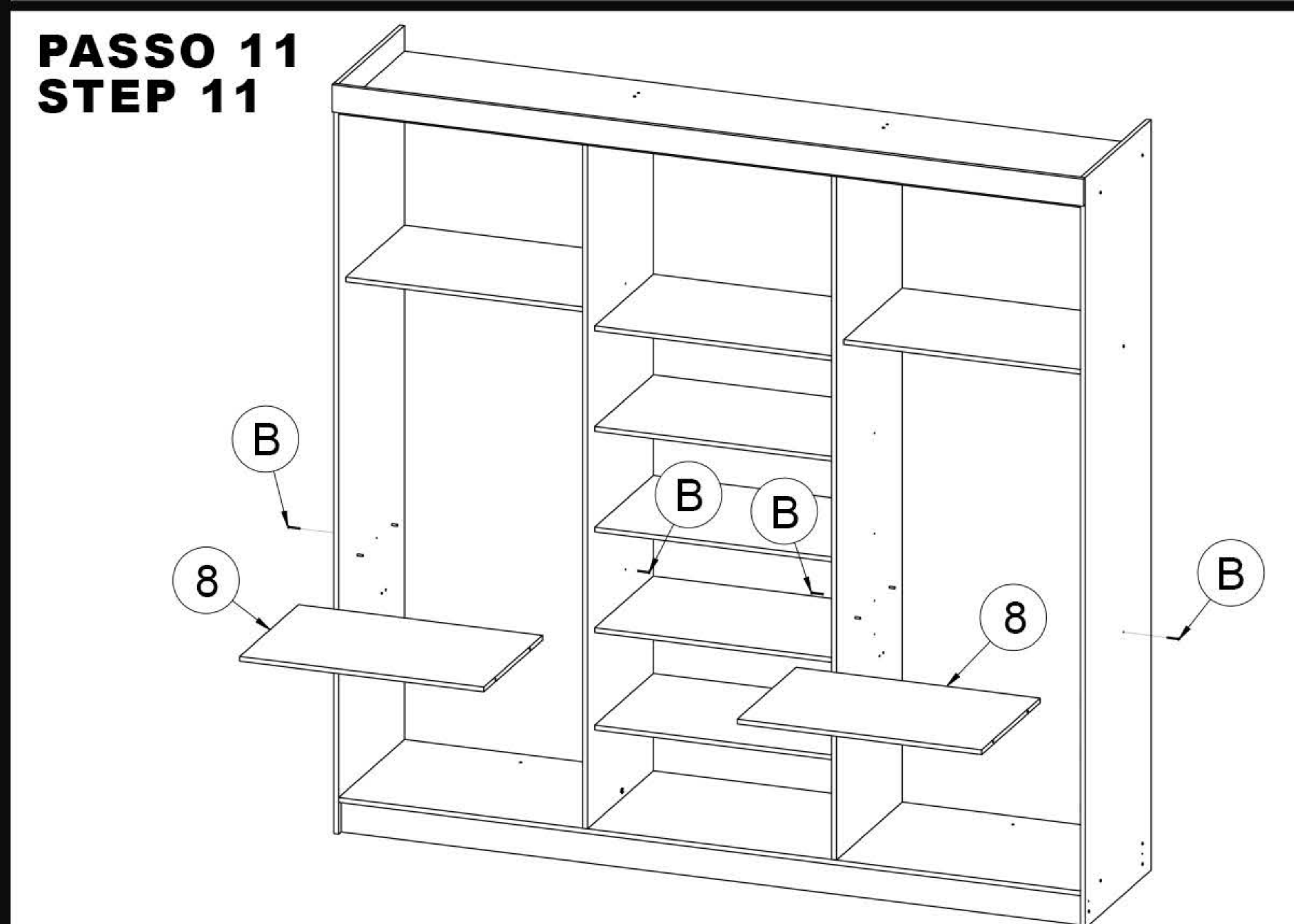

**PASSO 12
STEP 12**

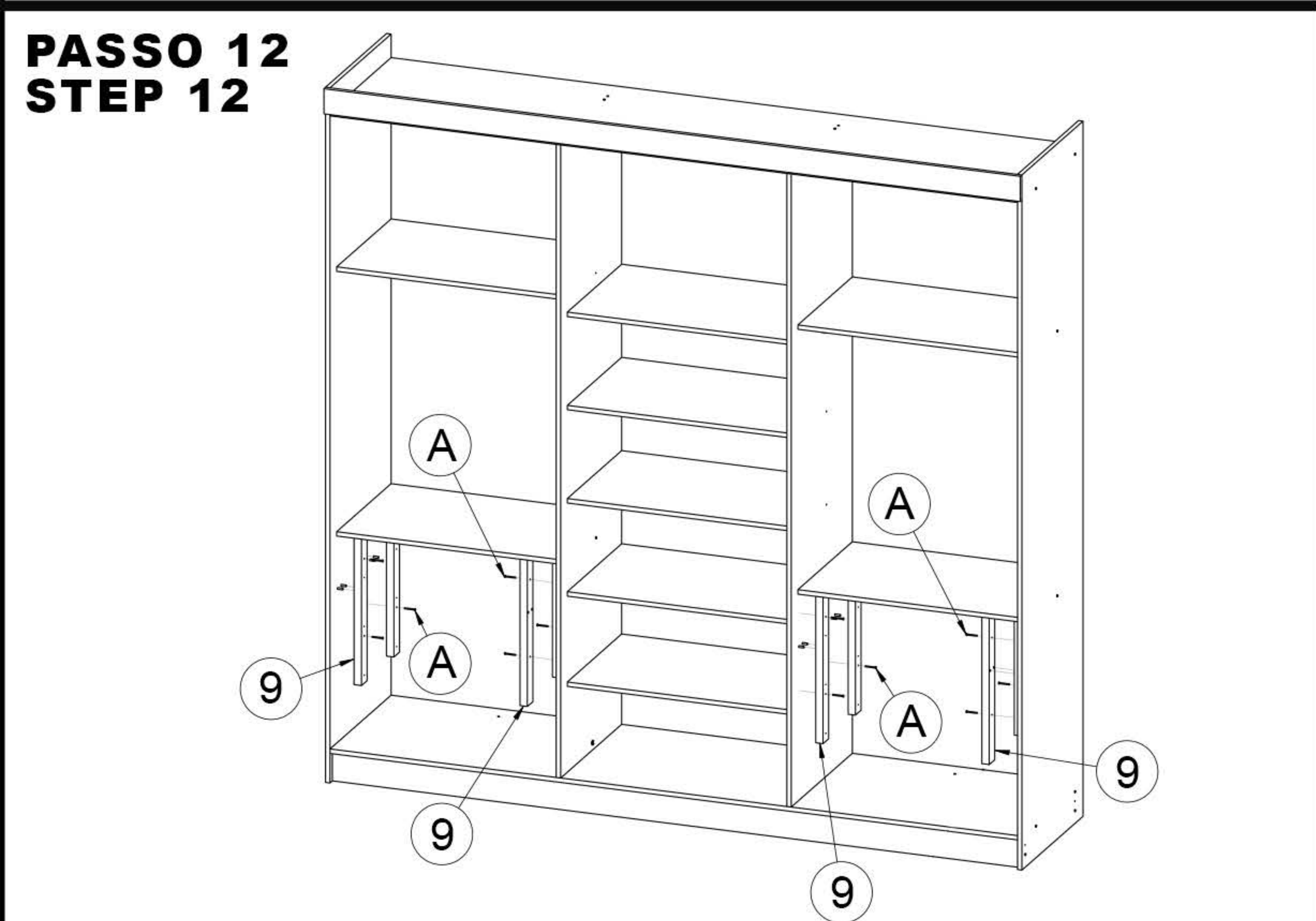

**PASSO 13
STEP 13**

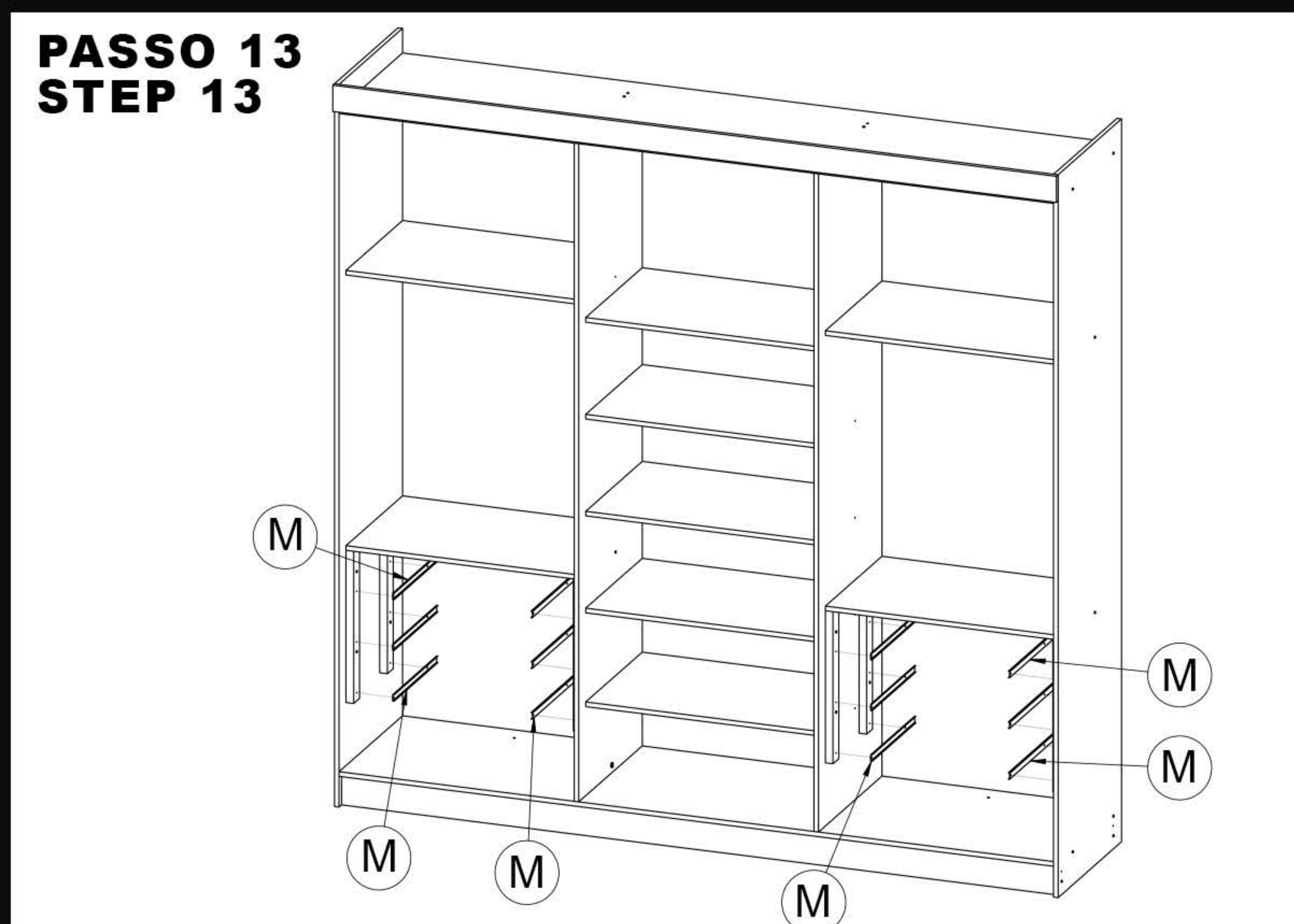

**PASSO 14
STEP 14**

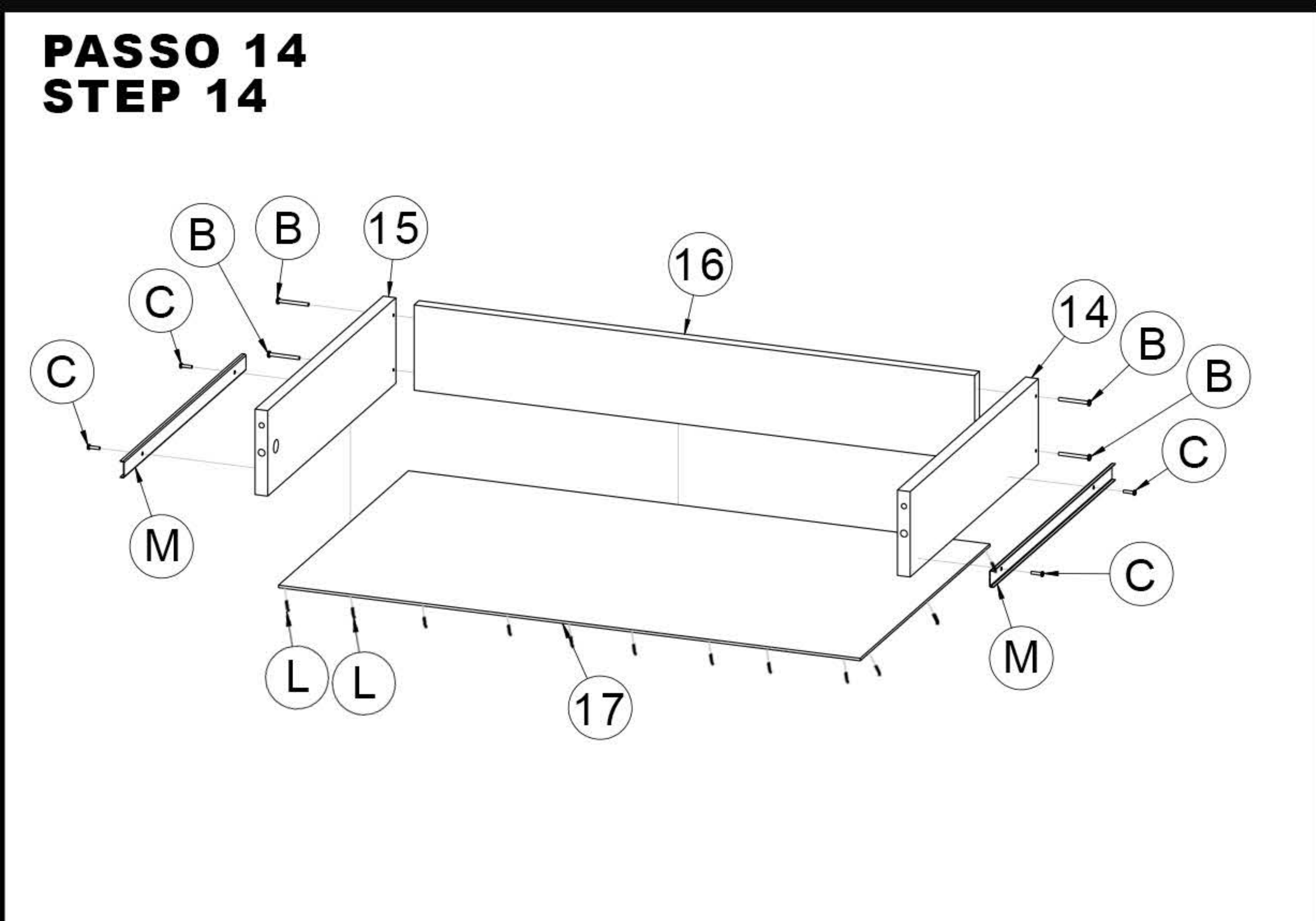

**PASSO 15
STEP 15**

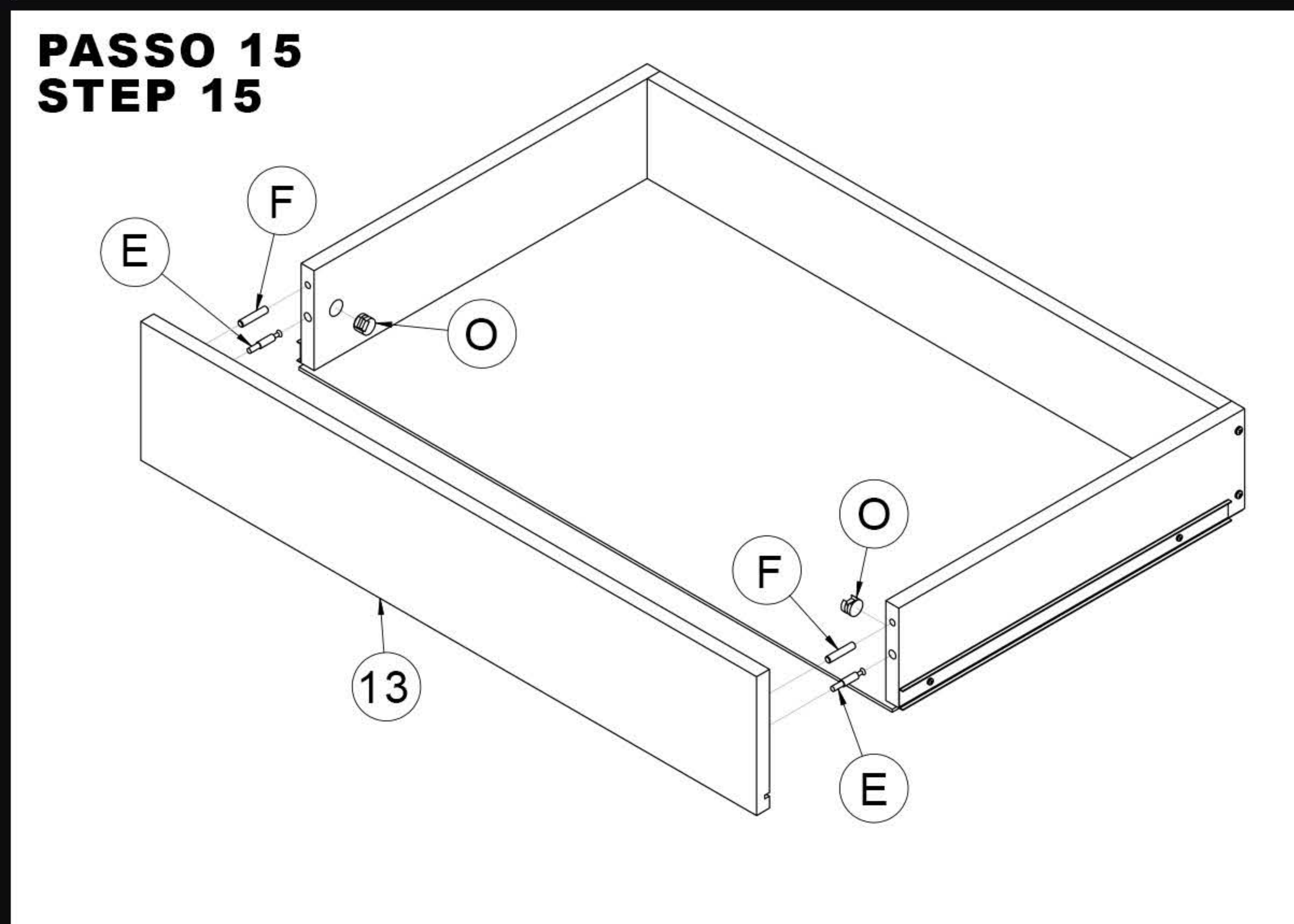

**PASSO 16
STEP 16**

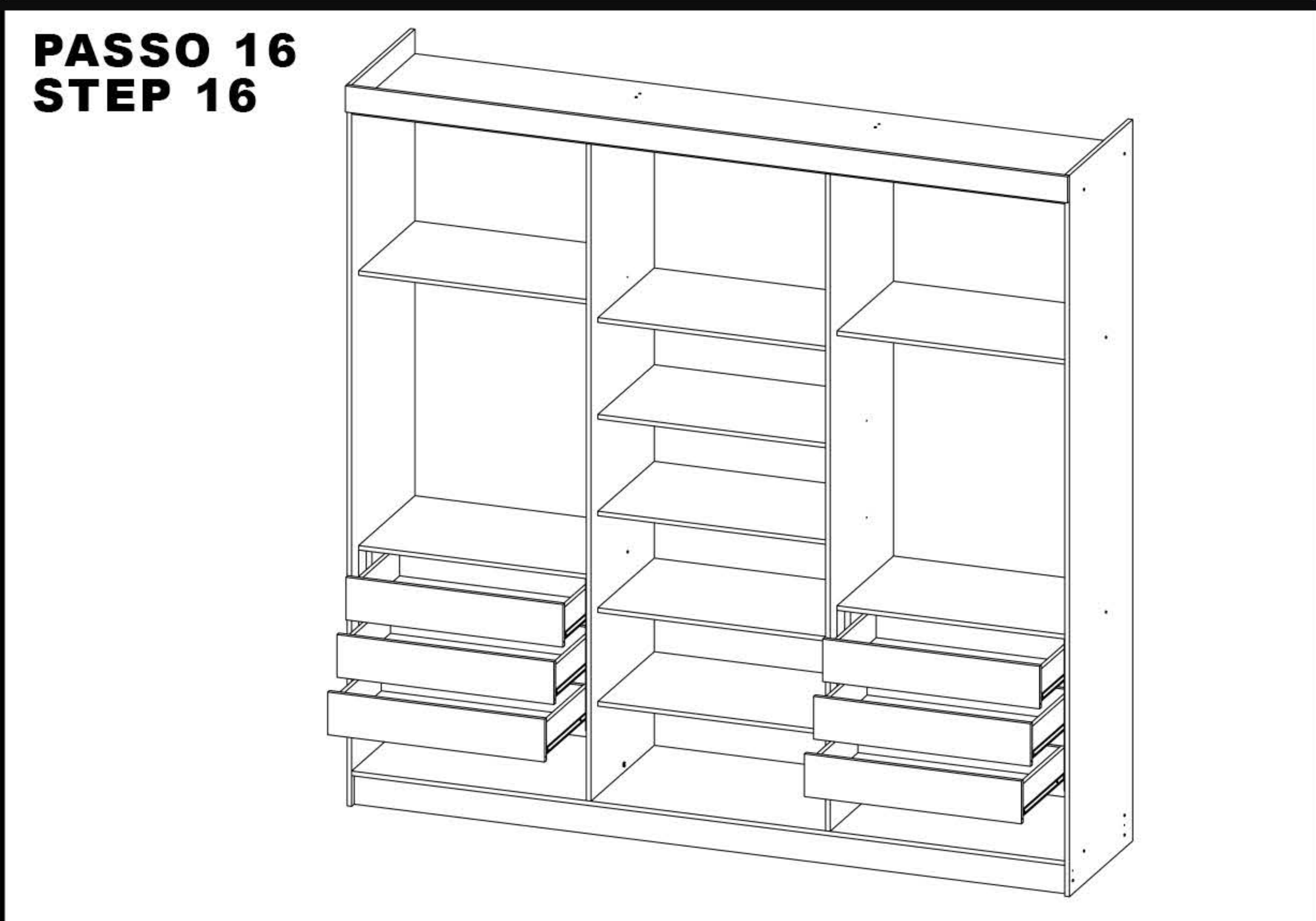

PASSO 17
STEP 17

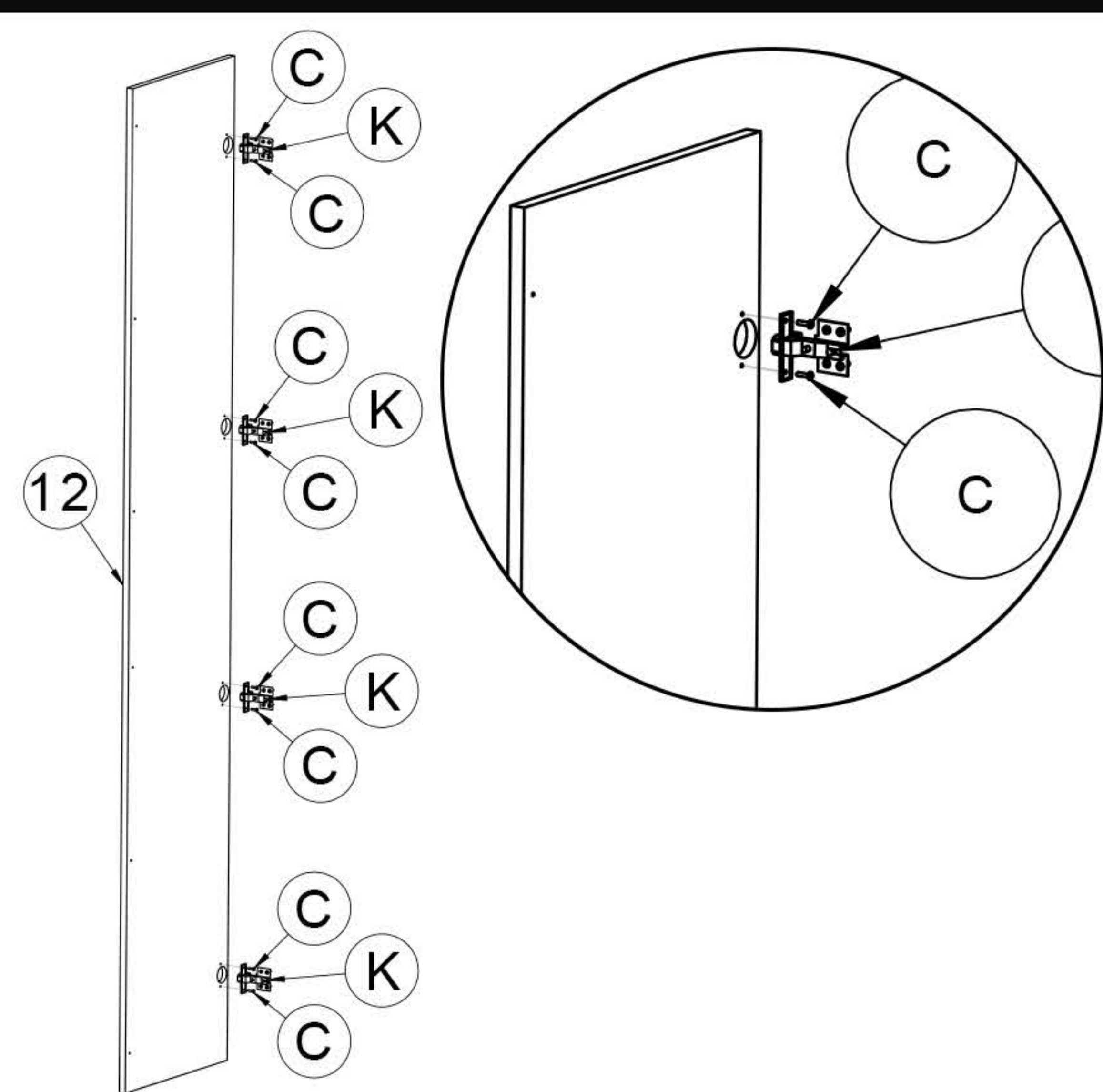

PASSO 18
STEP 18

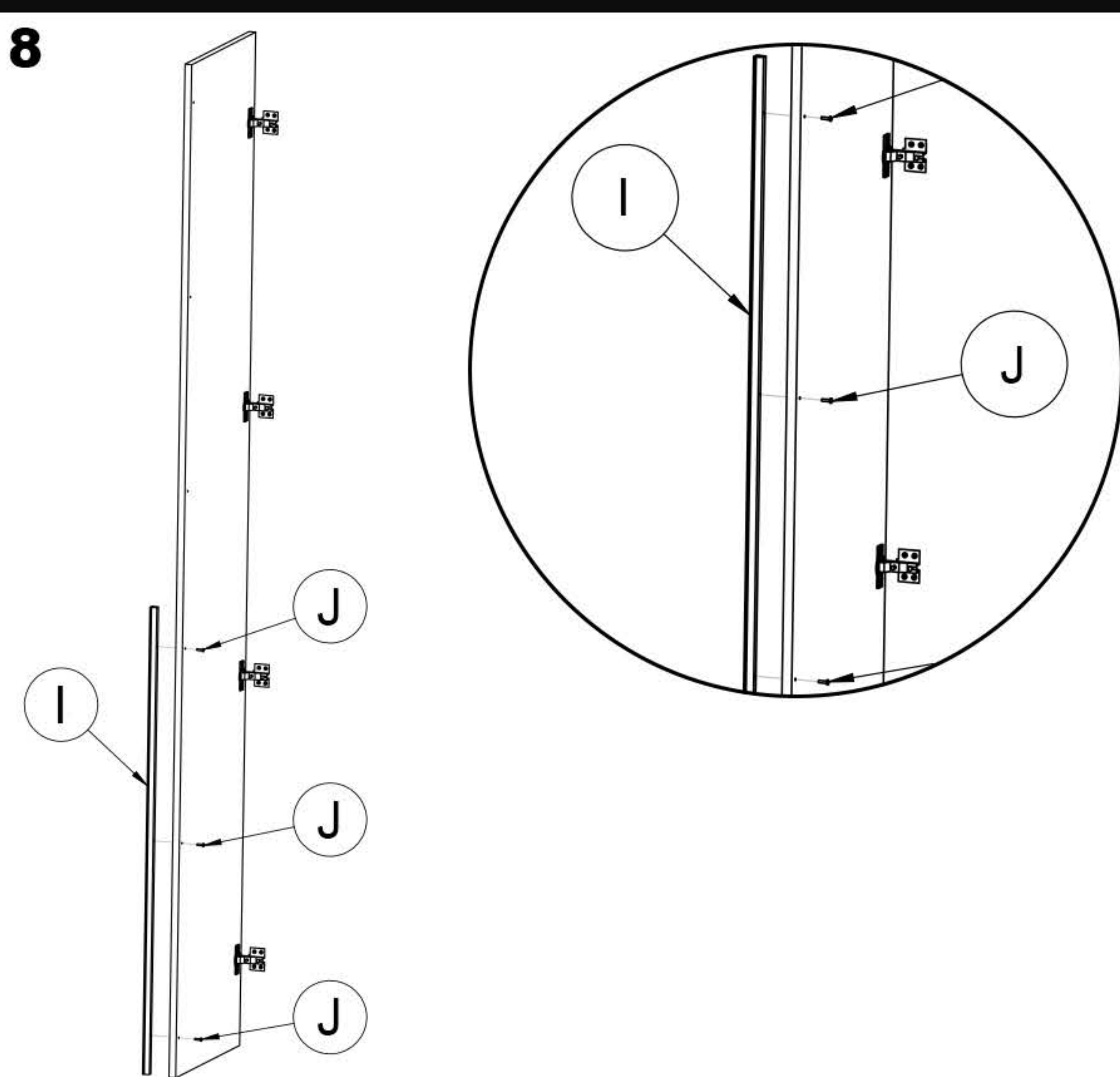

PASSO 19
STEP 19

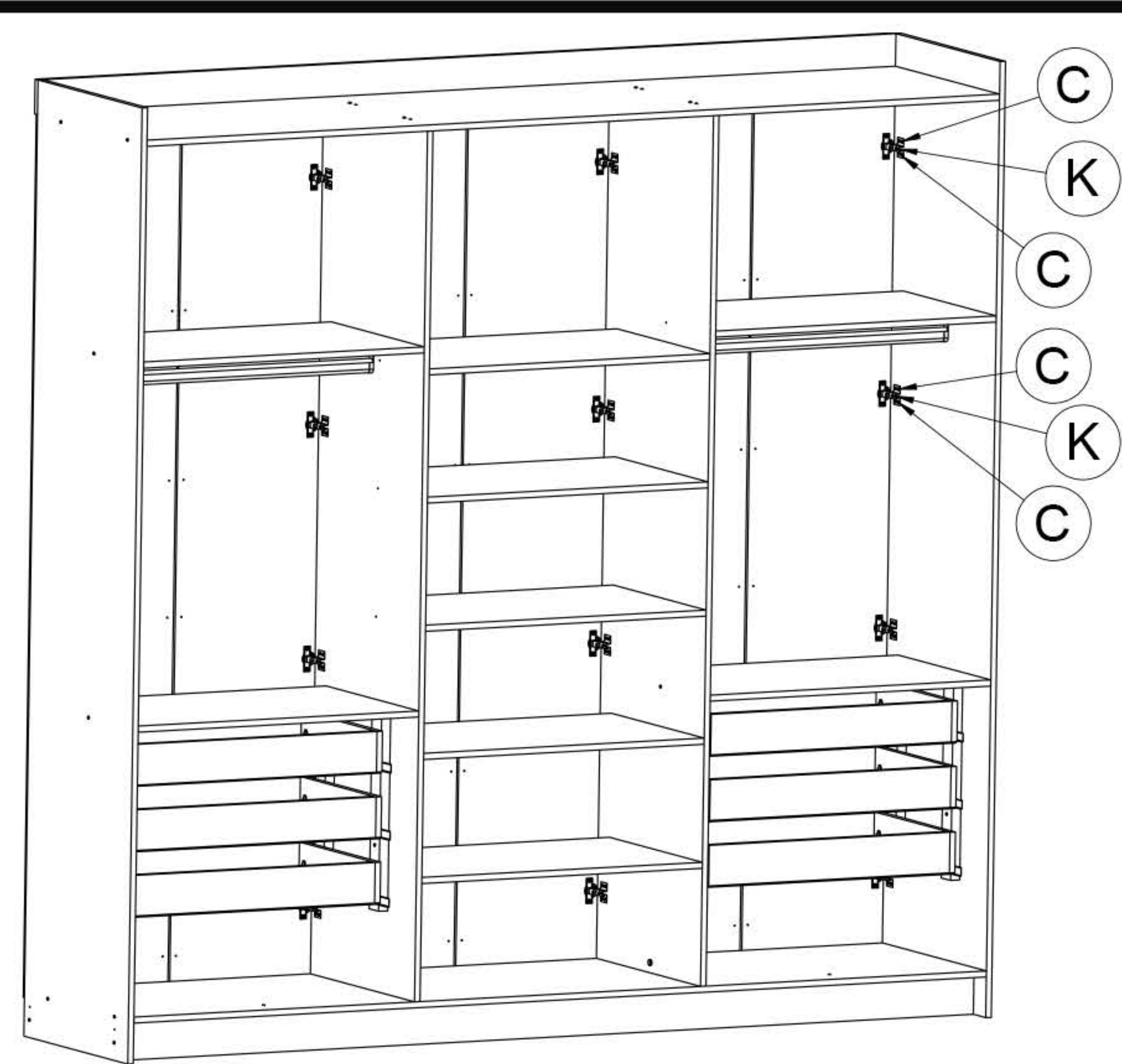

PASSO 20
STEP 20

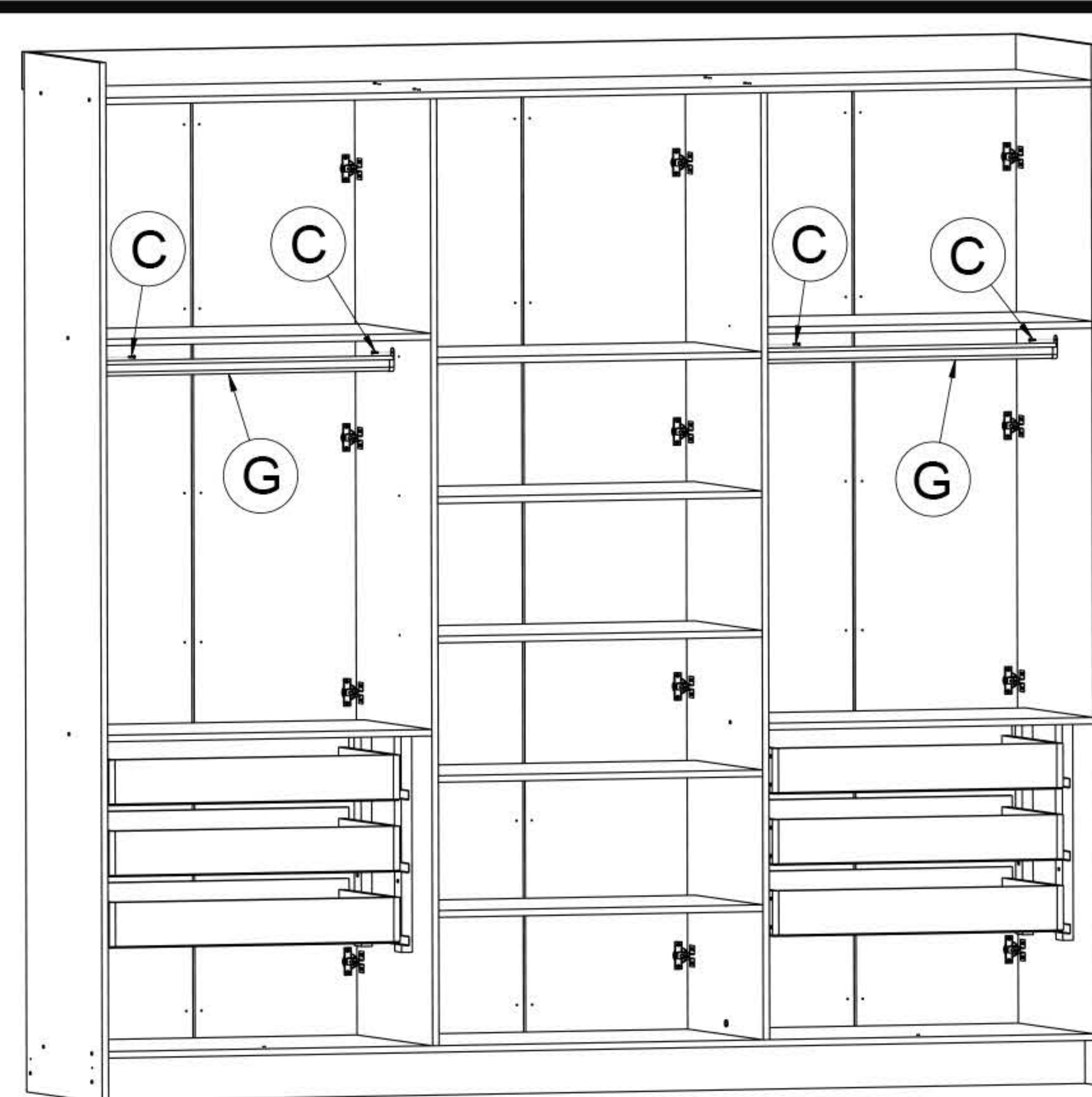

PASSO 21
STEP 21

