

8715 - GR FRIZATTO

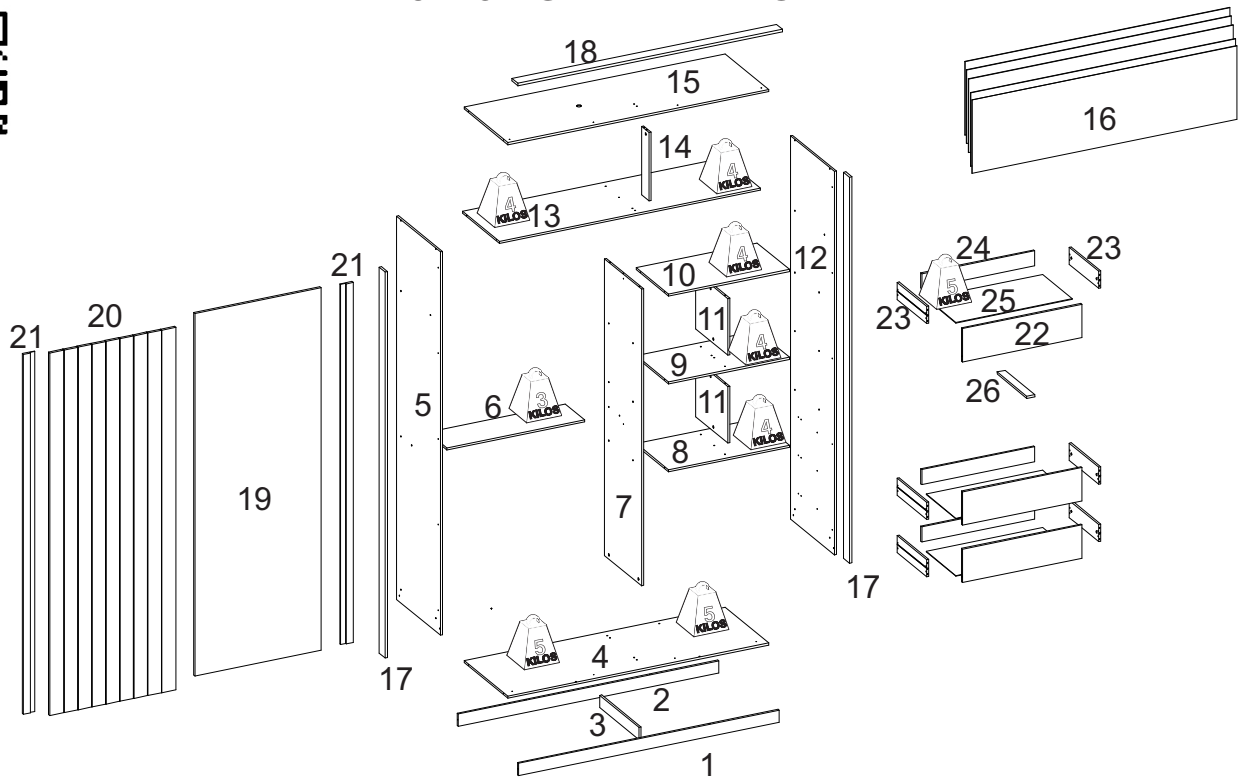

LISTA DE PEÇAS / PIECES LIST / LISTA DE PIEZAS

SEQ.	REF.	DESCRIÇÃO	DESCRIPTION	DESCRIPCIÓN	MAT.PRIMA	COMP.	LARG.	ESP.	QTD.
1	323794	Rodapé frontal	Front footer	Pie de página frontal	MDP	1552	72	12	1
2	323795	Rodapé traseiro	Back footer	Pie de página posterior	MDP	1552	72	12	1
3	323796	Trava rodapé	Footer lock	Bloqueo de pie de página	MDP	468	72	12	1
4	323797	Base	Basis	Base	MDP	1552	520	12	1
5	323798	Lateral esquerda	Left side	Lado izquierdo	MDP	2238	520	12	1
6	323799	Prateleira menor	Smaller shelf	Estante más pequeño	MDP	820	230	12	1
7	323800	Divisória	Partition	Dividir	MDP	1731	440	12	1
8	323801	Tampo do gaveteiro	Chest of drawers	Cajonera	MDP	720	385	12	1
9	323802	Prateleira do nicho	Niche shelf	Estante de nicho	MDP	720	385	12	1
10	323803	Prateleira	Shelf	Estante	MDP	720	385	12	1
11	323804	Divisória do nicho	Niche divider	Divisor de nicho	MDP	385	330	12	2
12	323805	Lateral direita	Right side	Lado derecho	MDP	2238	520	12	1
13	323806	Base do maleiro	Base of suitcase	Fondo de maleta	MDP	1552	440	12	1
14	323807	Batente superior	Top stop	Parada superior	MDP	399	88	12	1
15	323808	Chapéu	Hat	Sombrero	MDP	1552	520	12	1
16	323809	Fundo	Background	Fondo	HDF	1572	429	3	5
17	323810	Vista lateral	Side view	Vista lateral	MDP	2253	72	15	2
18	323811	Vista superior	Upper view	Vista superior	MDP	1576	72	15	1
19	323812	Porta	Door	Puerta	MDF	2116	750	15	1
20	323813	Porta com friso	Door with frieze	Puerta con friso	MDF	2116	750	15	1
21	323814	Vista da porta	Door view	Vista de la puerta	MDF	2106	72	15	2
22	323815	Frente de gaveta	Drawer front	Frente del cajón	MDP	710	195	12	3
23	701127	Lateral de gaveta	Drawer side	Lado del cajón	MDP	350	100	12	6
24	323817	Contra fundo	Against background	Contra el fondo	MDP	671	88	12	3
25	323818	Fundo da gaveta	Drawer bottom	Fondo del cajón	HDF	693	355	3	3
26	323832	Apoio de gaveta	Drawer support	Soporte de cajón	MDP	350	72	12	3

INSTRUÇÃO MONTAGEM PRODUTO
 Intructions to Assembly / Instrucciones de montaje

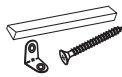

Separe as peças e acessórios de maneira organizada
 Separate parts and accessories in way organized
 Separe las piezas y accesorios de manera organizada

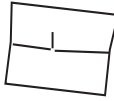

Forrar o chão com o papelão das embalagens.
 Cover the floor with the cardboard
 Cubra el suelo con la embalaje de cartón



É necessário 02 pessoas para montar o produto
 02 people are required to assemble the product
 Se requieren 02 personas para ensamblar el producto

O produto deve ser a montado por um profissional qualificado
 The product must be assembly by a professional
 El producto debe ser ensamblado por un profesional calificado

Ferramentas necessárias
 (não fornecidas)

Not include toóls / No herramientas



CUIDADO PARA CONSERVAÇÃO E LIMPEZA DO MÓVEL
 Care to conservation and clean / Cuidados de limpieza

Peso máximo de carga informado refere-se a objetos distribuido de maneira uniforme sobre toda área de contato da peça



The maximum load weight informed refers to objects distributed evenly over the entire contact area of the part
 Conjunto de carga máxima de peso se refiere a objetos distribuidos uniformemente sobre toda el área de contacto de la pieza de trabajo.



Não molhar o móvel e não expor em lugar úmido
 Do not wet the mobile and do not expose in a wet place
 No moje el producto y no exponer en un lugar húmedo



Não expor o móvel próximo de fontes de calor.
 Do not expose the mobile near heat sources
 no exponga cercano de fuentes de calor



Não usar produtos abrasivos.
 Do not use abrasive products.
 No utilice productos abrasivos.



Limpe com flanela limpa e seca.
 Clean with dry cloth
 Limpieza con un paño limpio y seco

LISTA DE ACESSÓRIOS E FERRAGENS / ACCESSORIES AND HARDWARE / ACCESORIOS Y HARDWARE



A- 700137-Parafuso 4,5x45 (37x)
 screw / tornillo



B- 700124-Parafuso 3,5x25 (27x)
 screw / tornillo



C- 700121-Parafuso 3,5x12 (118x)
 screw / tornillo



D- 700542-Cavilha 6x30 (30x)
 peg / cerrojo



E- 700146-Parafuso minifix (13x)
 Minifix screw /
 Tornillo minifix



F- 700148-Tambor Minifix (13x)
 Minifix Drum /
 Tambor minifix



G - 700113-Corrediça (3x)
 runners / corredera



H- 700419-Tapa furo minifix (50x)
 minifix cover / tapa minifix



I - 700516-Sache cola 20g (1x)
 Glue / Goma



J-700438-Suporte cabide (4X)
 hook support / soporte gancho



K- 700157-Prego (150x)
 nail / clavo



L- 700539-Cantoneira (4x)
 corner / esquina



M- 700490- kit com 6 Pés (1x)
 Foot / Pie



N- 701129-Perfil H (4x)
 Frame / Perfil



N - 700565-Gota Silicone (12x)
 wood support / Bastón



O - 701132-Cabideiro (2x)
 Coat Rack / Perchero

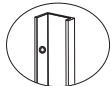

P- 701128-Anti empeno (2x)
 anti empeno / anti empeno



Q - 701131-Trilho superior (1x)
 top rail / carril superior

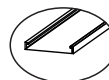

R - 701130-Trilho inferior (1x)
 Bottom rail / Riel inferior

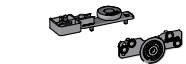
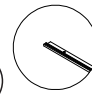

S- 701126-Kit porta correr (02x)
 bearing kit / kit de rodamentos



T- 700134-Parafuso 4,5x20 (8x)
 screw / tornillo

01° PASSO - Fixar acessórios nas peças 7 e 12

01° STEP - Fix accessories to parts 7 and 12

01° PASO - Fije los accesorios en las partes 7 y 12

C

G

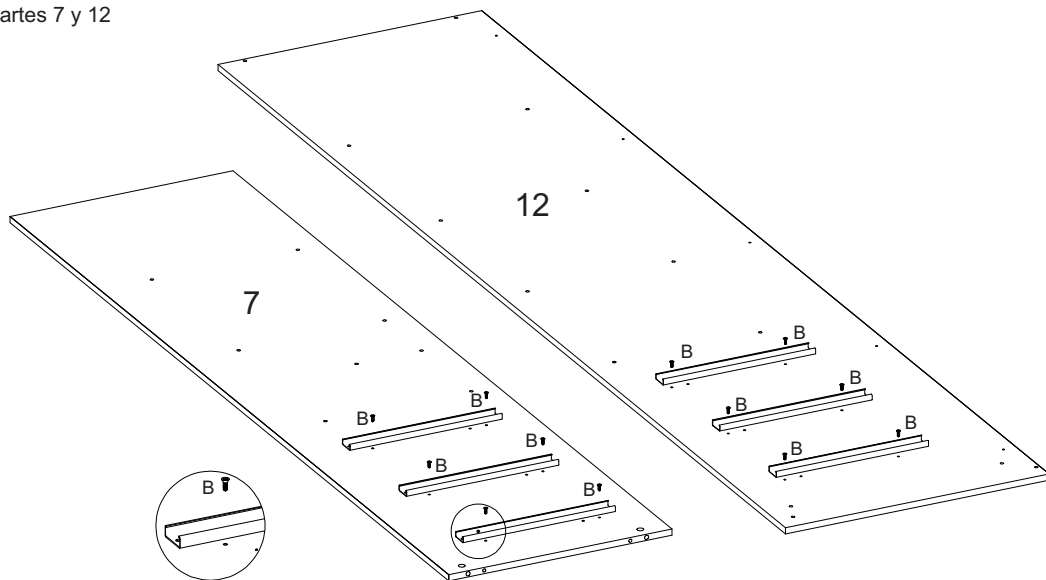

02° PASSO - Fixar a peças 1 e 2 na peça 3 / Fixar a peças 1,2 e 3 na peça 4

02° STEP - Fix parts 1 and 2 to part 3 / Fix parts 1,2 and 3 to part 4

02° PASO - Fije las partes 1 y 2 a la parte 3 / Fije las partes 1,2 y 3 a la parte 4

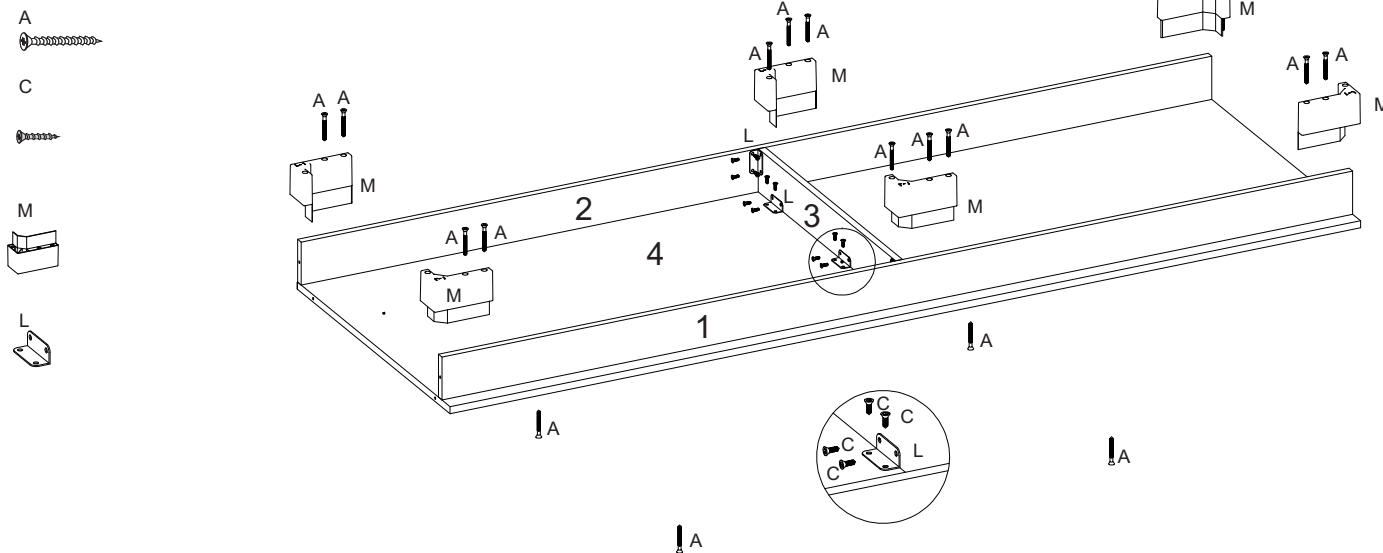

03° PASSO - Fixar peça 5 nas peças 1,2,4 e 6

03° STEP - Fix part 5 to parts 1,2, 4 and 6

03° PASO - Fije la parte 5 a las partes 1, 2, 4 y 6

A

G

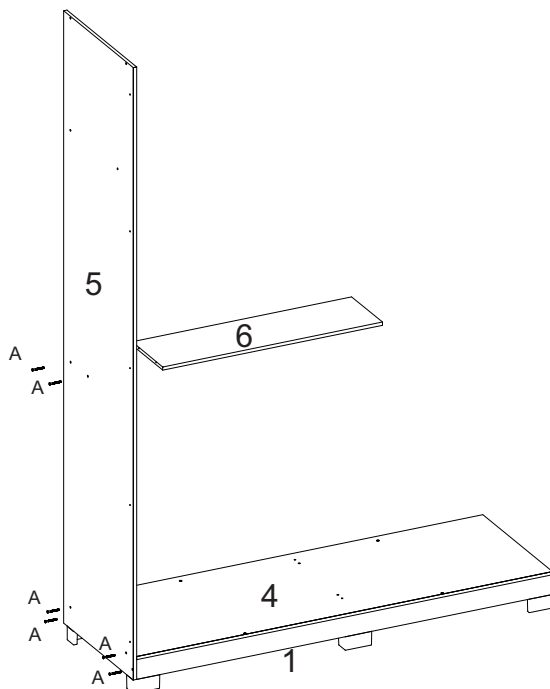

04° PASSO - Fixar peça 7 nas peças 4 e 6

04° STEP - Fix part 7 to parts 4 and 6

04° PASO - Fije la partes 7 a las partes 4 y 6

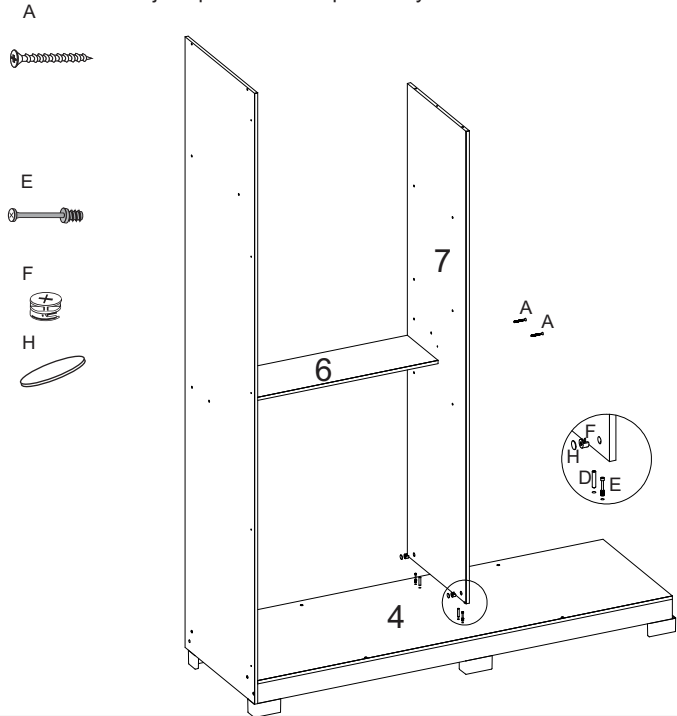

05° PASSO - Fixar peça 12 nas peças 1 e 2. Fixar peça 8 nas peças 7 e 12

05° STEP - Fix part 12 to parts 1 and 2. Fasten part 8 to parts 5 and 9

05° PASO - Fije la parte 9 a las partes 1, 3 y 4. Fije la parte 8 a las partes 5 y 9

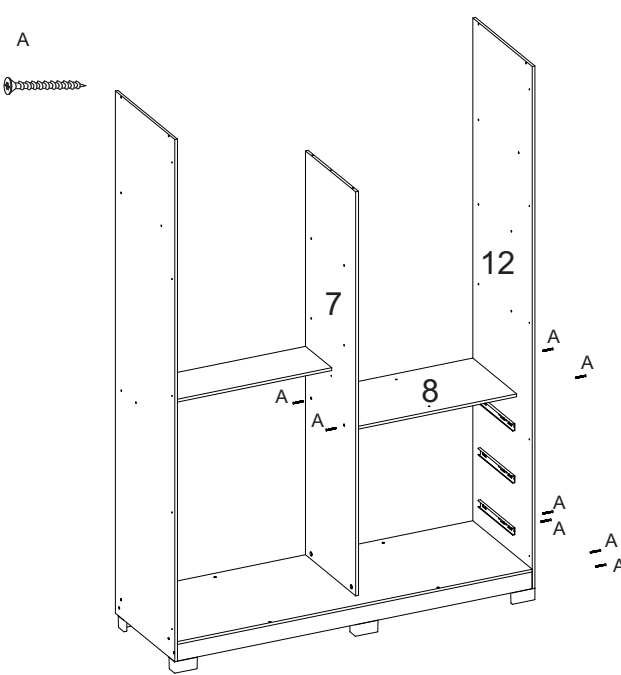

06° PASSO - Fixar as peça 11 nas peças 8 e 9. Fixar peça 9 nas peças 7, 11 e 12

06° STEP - Fix part 11 to parts 8 and 9. Attach parts 9 to parts 7, 11 and 12

06° PASO - Fije la parte 11 a las partes 8 y 9. Fijar la partes 9 a las partes 7, 11 y 12

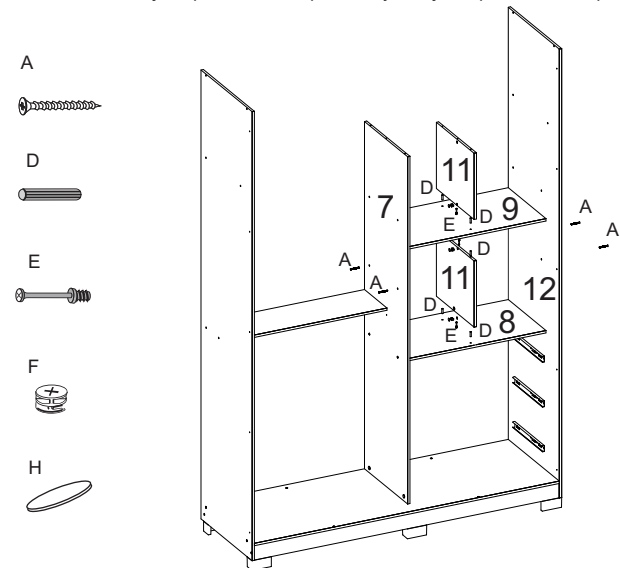

07° PASSO - Fixar peça 13 nas peças 5, 7 e 12

07° STEP - Fix part 13 to parts 5, 7 and 12

07° PASO - Fije la parte 12 a las partes 5, 7 y 12

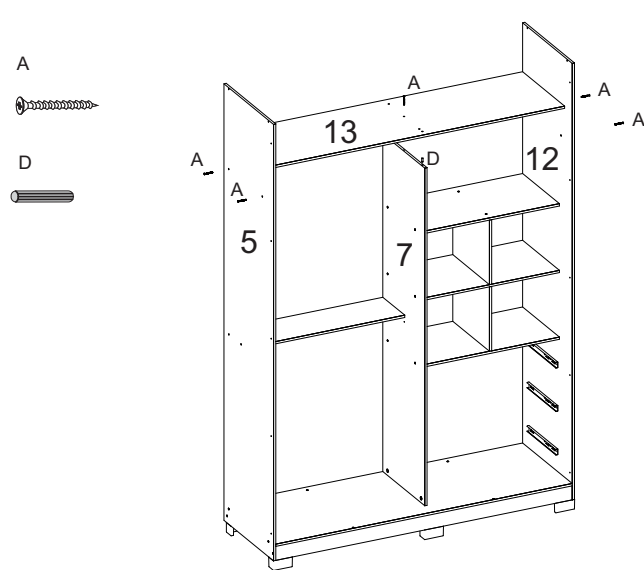

08° PASSO - Fixar 14 nas peças 13 e 15. Fixar 15 nas peças 4, 12 e 14

08° STEP - Fix part 14 to parts 13 and 15. Fasten part 15 to parts 4, 12 and 14

08° PASO - Fije pieza 14 a las piezas 13 y 15. Fije pieza 15 a las piezas 4, 12 y 14

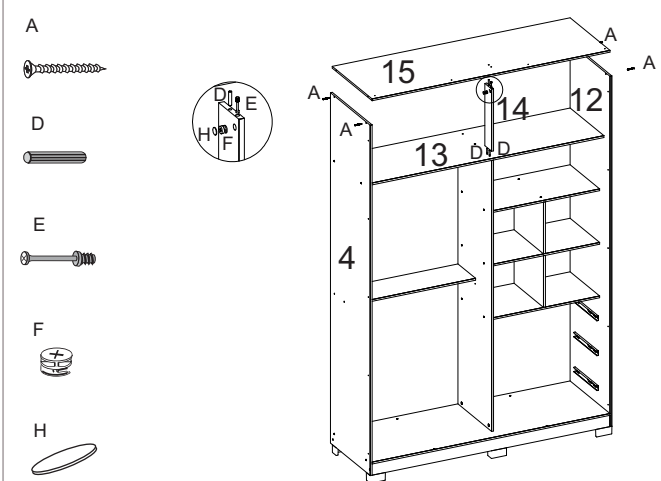

09° PASSO - Fixar peças 16 na parte de tras do produto

09° STEP - Fix Fixing parts 16 on the back of the product

09° PASO - Fije Piezas 16 en la parte posterior del producto

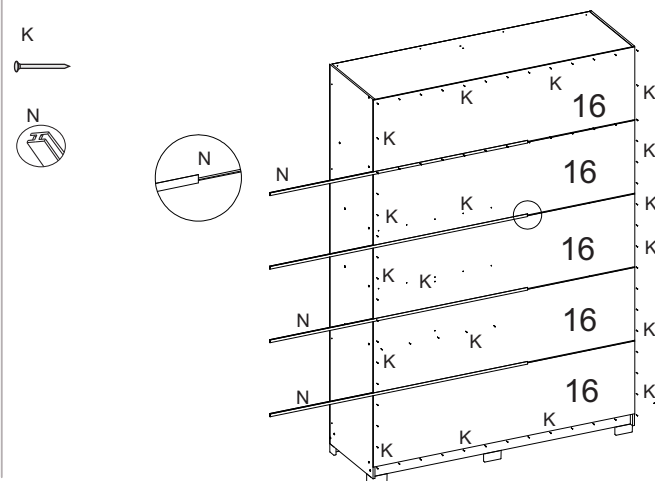

10° PASSO - Fixar peças 17 e 18 nas peças 5, 12 e 15

10° STEP - Fix parts 17 and 18 to parts 5, 12 and 15

10° PASO - Fije las partes 17 y 18 con las partes 5, 12 y 15

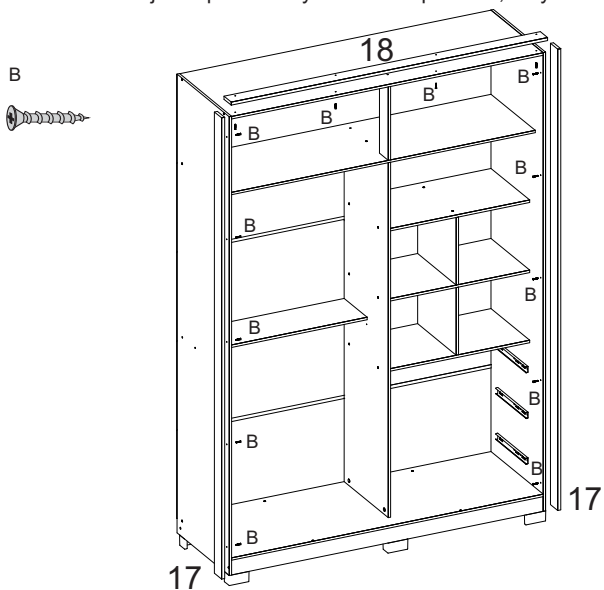

11° PASSO - Fixar os acessórios indicados na peças

11° STEP - Fix accessories indicated in parts

11° PASO - Fije los accesorios indicados en las partes

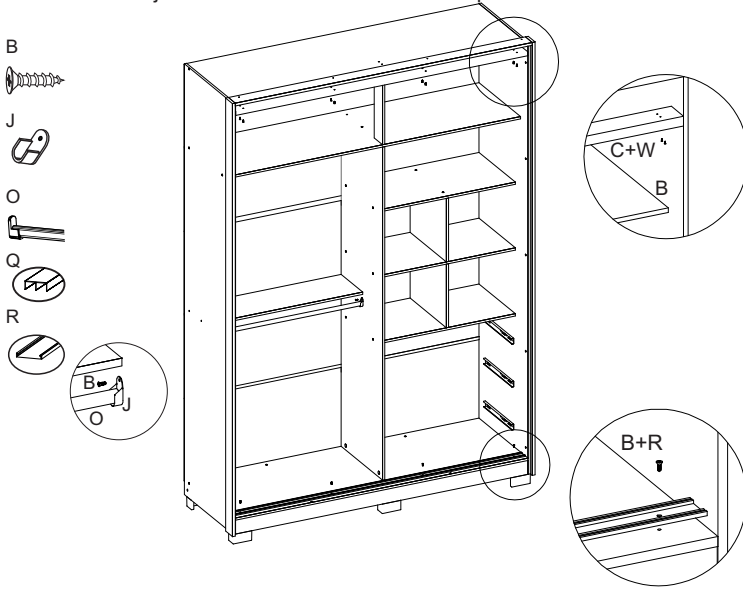

14° PASSO - Fixar peças 23 nas peças 22 e 24. Fixar peça 25 nas peças 23 e 24

14° STEP - Fix 23 to parts 22 and 24. Fix part 25 to parts 23 and 24

14° PASO - Fijar la pieza 23 en las piezas 22 y 24. Fijar la pieza 25 en las piezas 23 y 24

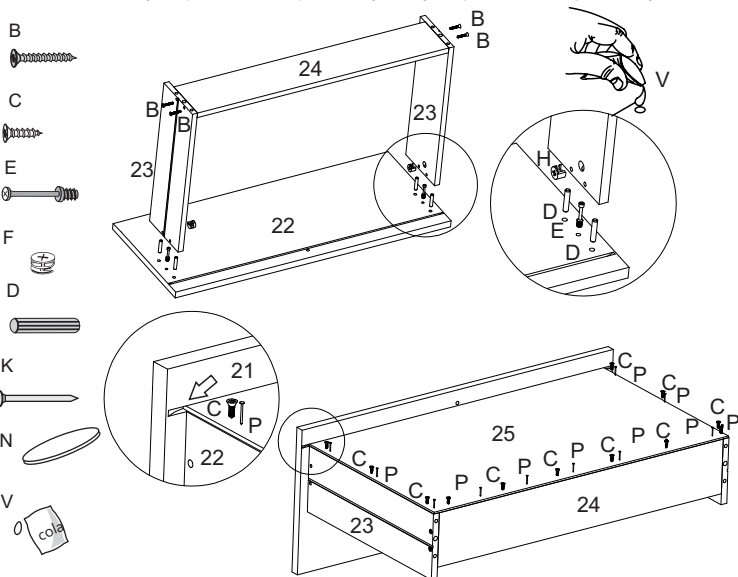

15° PASSO - Fixar peça 26 nas peças 22 e 24

15° STEP - Fix part 26 to parts 22 and 24

15° PASO - Fijar la parte 26 a las partes 22 y 24

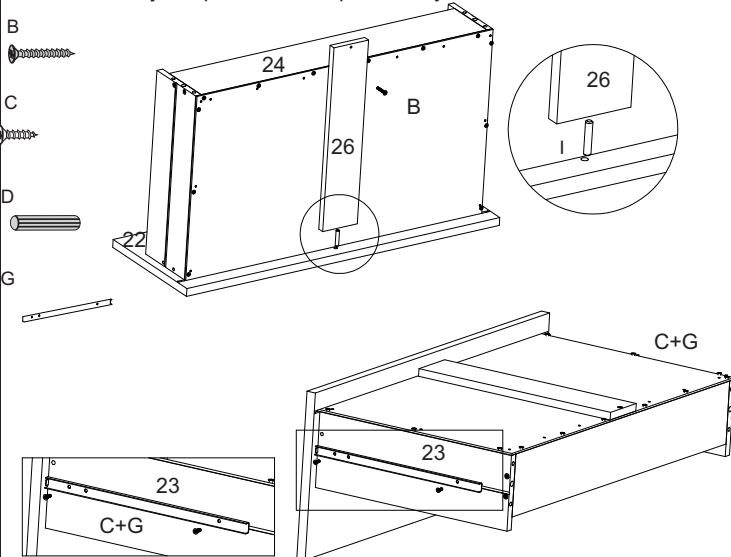

14° PASSO - Fixar peça 21 nas peças 19 e 20

14° STEP - Fix part 21 to parts 19 and 20

14° PASO - Fijar la parte 21 a las partes 19 y 20

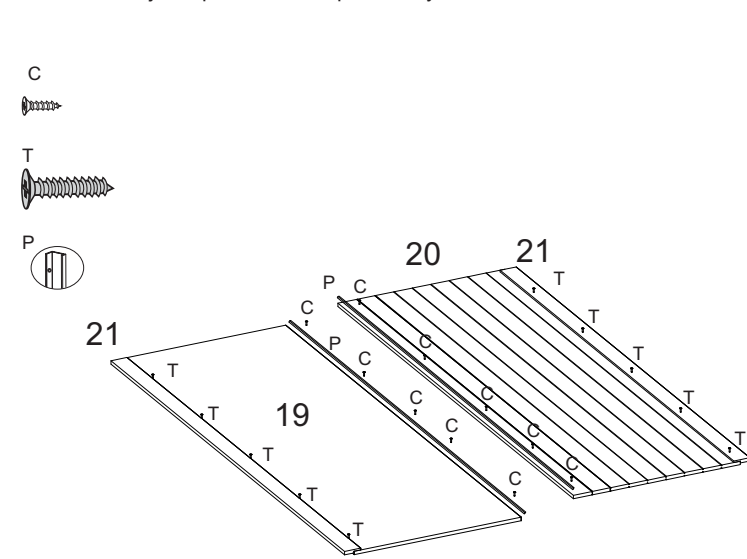

15° PASSO - Fixar peças 19 e 20 com o acessório (S)

15° STEP - Fix parts 19 and 20 with the accessory (S)

15° PASO - Fije las piezas 19 y 20 con el accesorio (S)

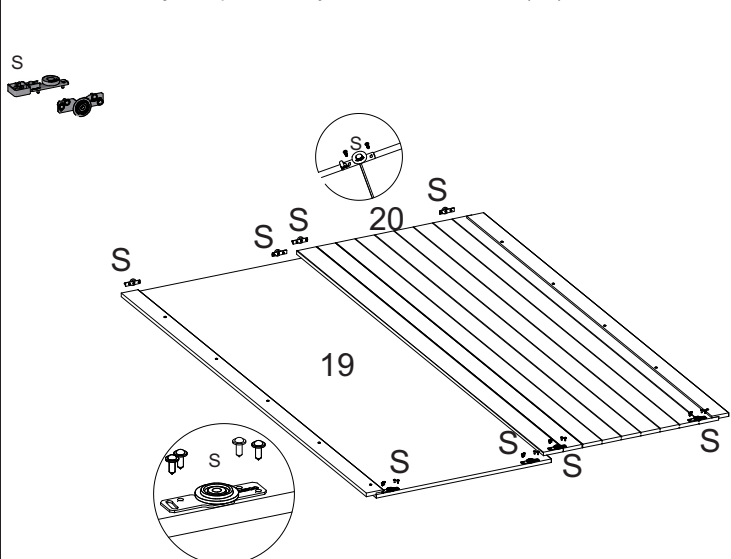

16° PASSO - Encaixar as portas nos trilhos

16° STEP - Fitting the doors to the rails

16° PASO - Montaje de las puertas en los carriles

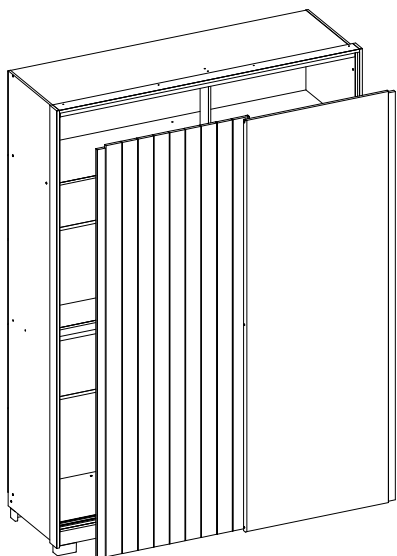

Aspecto final do produto

Final appearance of the product

Aspecto final del producto

