

GOLD

sapateira | zapatera | shoe storage

Manual de montagem | Manual de montaje | Assembly instructions

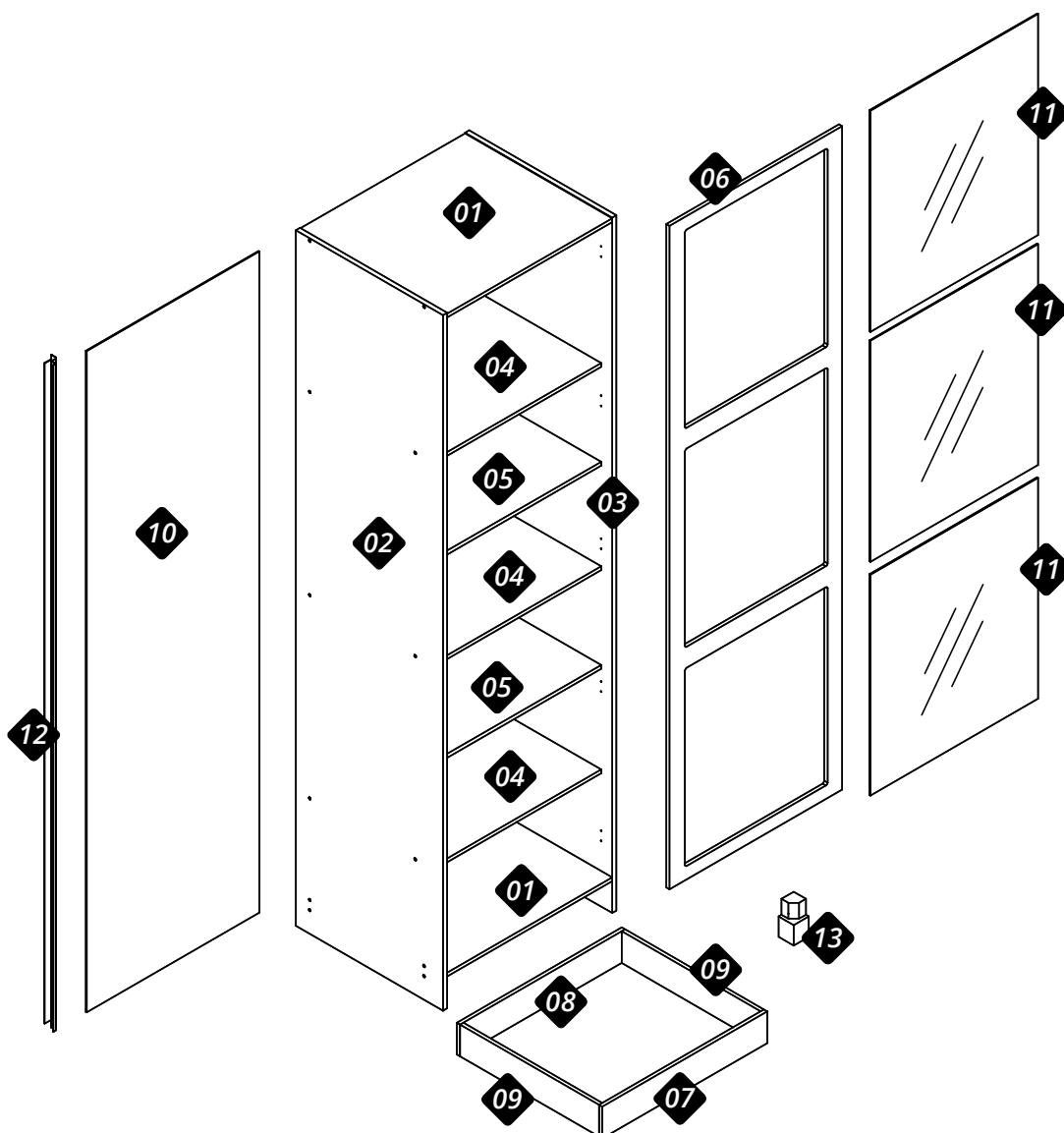
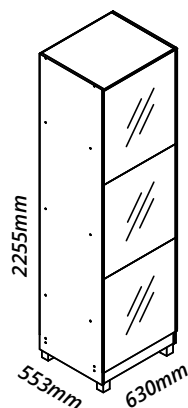

Nº	Cód.	Peças	Piezas	Parts	Medida / Size	Qtd.	Vol.
01	07305	Base / Tampo	Base / Cubierta	Base / Top	600x535x12	02	02
02	07300	Lateral esquerda	Lateral izquierda	Left side	2190x535x15	01	02
03	07301	Lateral direita	Lateral derecha	Right side	2190x535x15	01	02
04	07304	Prateleira fixa	Estante fija	Fixed shelf	600x495x12	03	02
05	07306	Prateleira movel	Estante movible	Adjustable shelf	600x495x12	02	02
06	07303	Porta	Puerta	Door	2090x628x12	01	02
07	07307	Rodape frontal	Rodapíe frontal	Lower front crossbar	600x100x12	01	02
08	07308	Rodape traseiro	Rodapíe trasero	Lower rear crossbar	600x100x12	01	02
09	07204	Trava de rodape	Traba del rodapíe	Smaller crossbar	505x100x12	02	02
10	07309	Fundo	Fondo	Bottom	2085x628x2,5	01	02
11	30017778	Kit espelho	Kit espejo	Mirror kit	696x610x3	01	01
12	30017776	Puxador	Tirador	Handle	2090mm	01	02
13	30017716	Kit pé	Kit píe	Foot kit		01	02

Recorte aqui e guarde seu certificado de garantia!



Certificado de garantia

A Gelius Indústria de Móveis confia na qualidade de seus produtos e por isso o garante pelo prazo de 90 dias para defeitos de fabricação em condições normais de uso.

Resultarão nula a garantia e sem efeito a cobertura, se o produto, (incluindo vidros e ou espelhos que o compõe):

- sofrer dano provocado por acidente, agente da natureza.
- uso indevido ou maus tratos como arrastar, subir em cima, colocar produtos com excesso de peso).
- não utilizado para os fins a que se destina.
- conter manchas provocadas por uso de produtos químicos em sua limpeza.
- excesso de umidade ou água.

Ao detectar qualquer defeito em seu móvel, entre em contato com a loja onde foi efetuada a compra. A comprovação de que o móvel a ser consertado ou substituído encontra-se dentro do prazo de garantia é de total responsabilidade do fabricante e deve ser feita mediante a apresentação desse certificado corretamente preenchido e sem rasuras ou resalvas.

Cuidados com seu móvel Gelius!

- para limpeza do seu móvel, utilize apenas pano macio e seco.
- jamais limpe-o com palha de aço, álcool ou qualquer outro produto químico ou abrasivos, óleos de peroba ou produtos do gênero.
- evite deixá-lo sob raios solares ou chuva.
- ao transportar o seu móvel Gelius, prenda-o firmemente para que não ocorra quedas indesejáveis.

Seguindo corretamente as informações acima, você conservará por muito mais tempo o seu móvel Gelius!

GARANTIA DO CLIENTE:

Cliente: _____

Rua: _____ Nº: _____ Bairro: _____

Cidade: _____ UF: _____ Loja onde comprou: _____

Data da compra: ____/____/____ Nota Fiscal: _____

Data da reclamação na loja: ____/____/____

Defeito constante: _____

Recomendações | Recomendaciones | Recommendations

Atenção
 Atención
 Attention

Este produto deve ser montado por um profissional.

Este producto debe ser ensamblado por un profesional.

This product must be assembled by a professional.

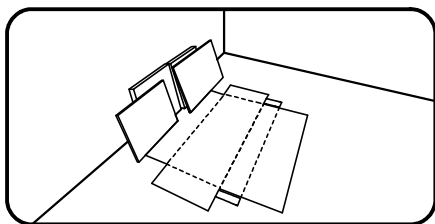

Antes de começar a montagem prepare o ambiente, deixando-o completamente limpo e com bom espaço para iniciar o trabalho. Utilize o papelão da própria embalagem para separar e apoiar as peças retiradas da caixa.

Antes de comenzar el montaje preparar el ambiente, dejándolo completamente limpio y con buen espacio para comenzar el trabajo. Utilice el cartón de la embalaje para separar y apoyar las piezas desmontadas de las cajas.

Prepare the room before starting the assembly, leaving it completely clean and the area in good condition to start the work. Use the cardboard of the packaging to separate and support the parts removed from the boxes.

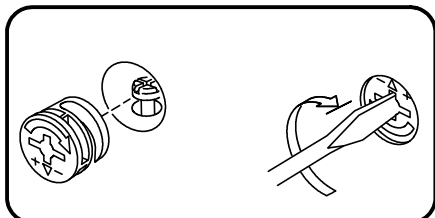

Como usar o acessório Pino e Tambor Minifix (quando utilizado no produto).

Como usar el herraje Pino y Tambor Minifix (cuando se usa en el producto).

How to use the Minifix Set (when used in the product).

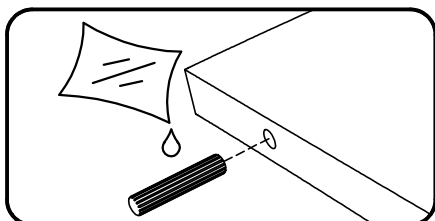

Aplicar cola nas cavilhas de madeira (quando utilizado no produto).

Aplicar pegamento a las clavijas de madera (cuando se usa en el producto).

Apply glues to the wooden dowels (when used in the product).

Ferramentas recomendadas para montagem | Herramientas de montaje recomendadas | Recommended tools

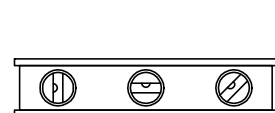
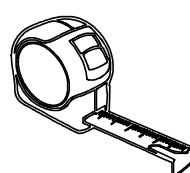
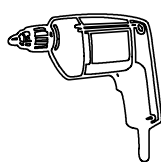
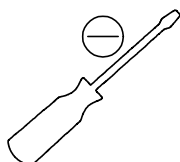
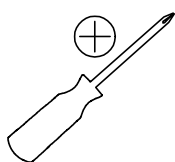

Acessórios e ferragens | Herrajes | Hardware

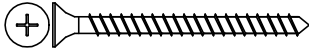

A) cód. 30001098 012 un.

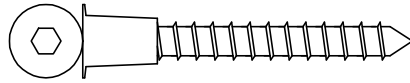

B) cód. 30008477 020 un.

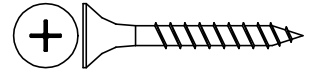

C) cód. 30000716 004 un.



D) cód. 30000730 014 un.



E) cód. 30000711 057 un.



F) cód. 30010093 002 un.

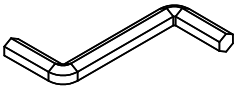

G) cód. 30001224 001 un.



H) cód. 30000797 008 un.

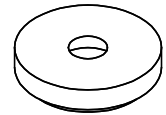

I) cód. 30000853 004 un.

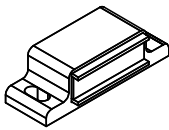

J) cód. 30011233 003 un.

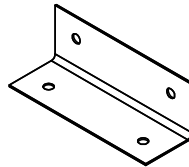

K) cód. 30003829 008 un.

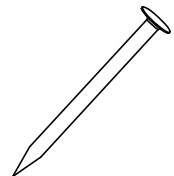

L) cód. 30000783 050 un.

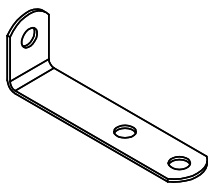

M) cód. 30012846 002 un.

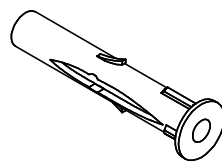

N) cód. 30011974 002 un.

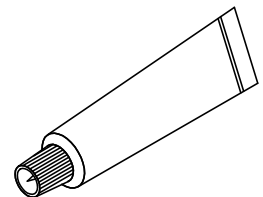

O) cód. 30017678 002 un.

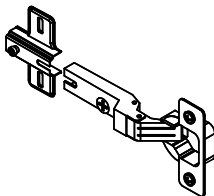

P) cód. 30016616 005 un.

ATENÇÃO

Sr.(a) Montador (a)

***Instruções de montagem
da porta de espelho***



***Acesse o QR Code para
assistir ao video de montagem.***

03

Utilize a caixa de embalagem para forrar o chão para montagem da porta.

- Com um pano seco, limpe a superfície dos espelhos e da porta.
- Retire as películas protetoras da fita dupla-face dos espelhos.
- Aplique a cola de espelho nos pontos indicados
- Importante: após aplicar, não esparramar a cola.

Tempo mínimo de secagem da cola: entre 12 e 24 horas.

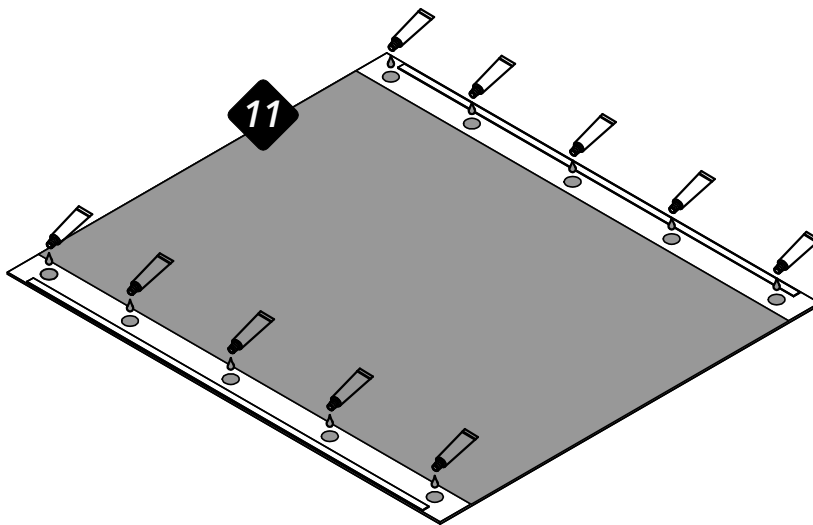
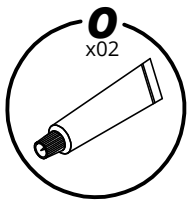

04

- Fixar os espelhos fazendo com a porta do lado indicado
- Pressione bem os espelhos durante 10 segundos.
- Repete a processo para cada espelho.

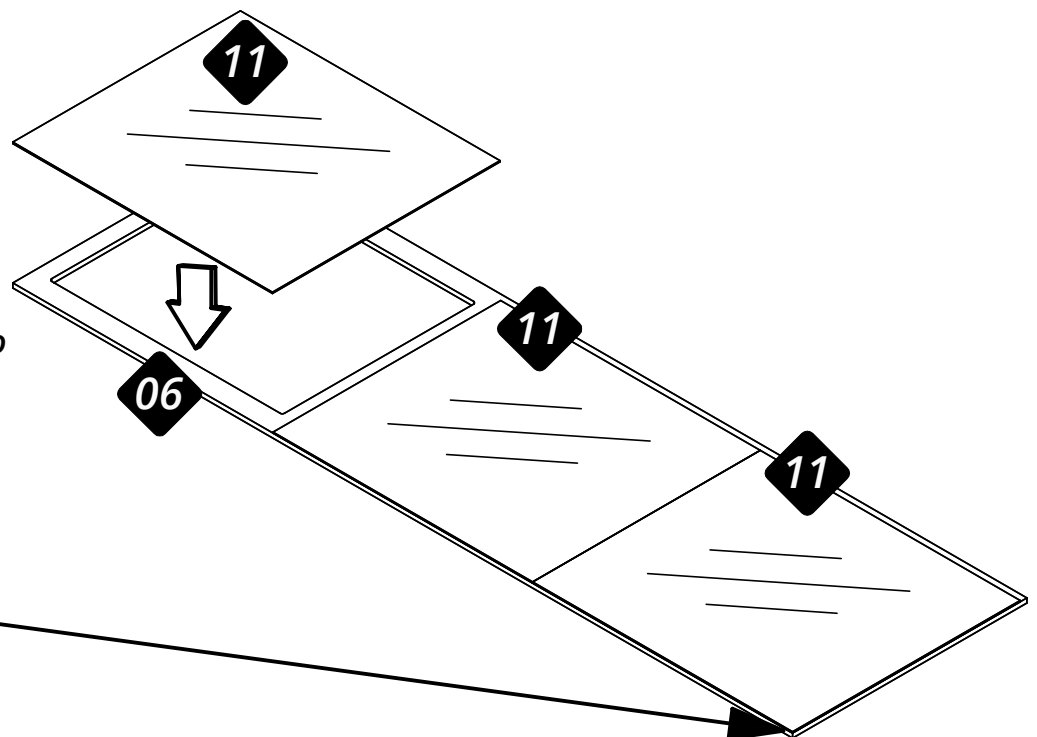

Detalhe da fixação do espelho

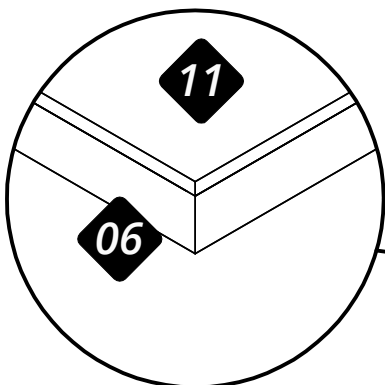

05

Atenção: Este produto tem opções de montagem do lado esquerdo e direito.

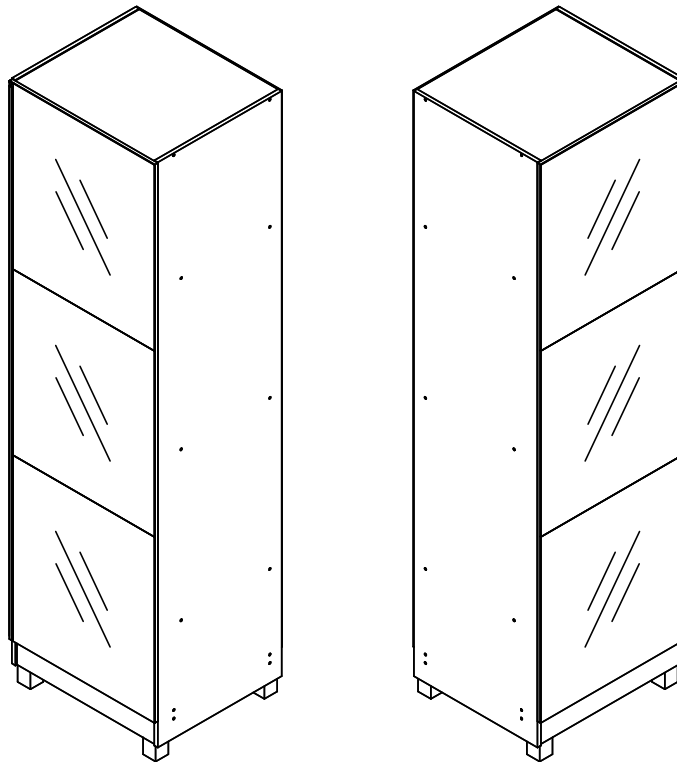

06

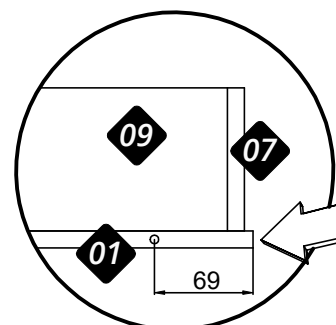
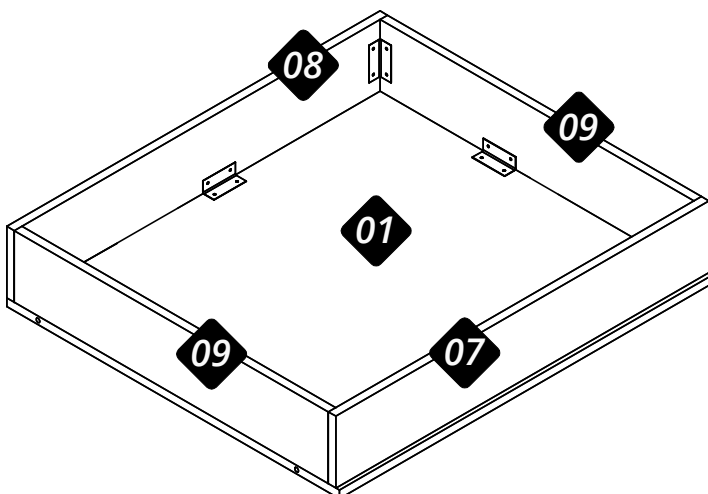
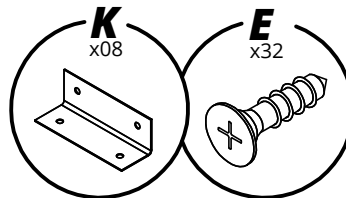
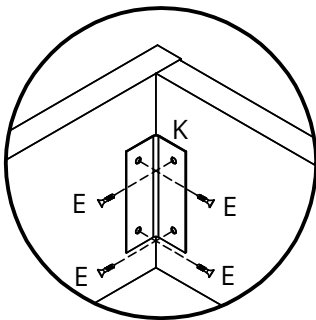

ATENÇÃO:
Frente da base.

ATENCIÓN:
Frente del base.

ATTENTION:
Front of base.

07

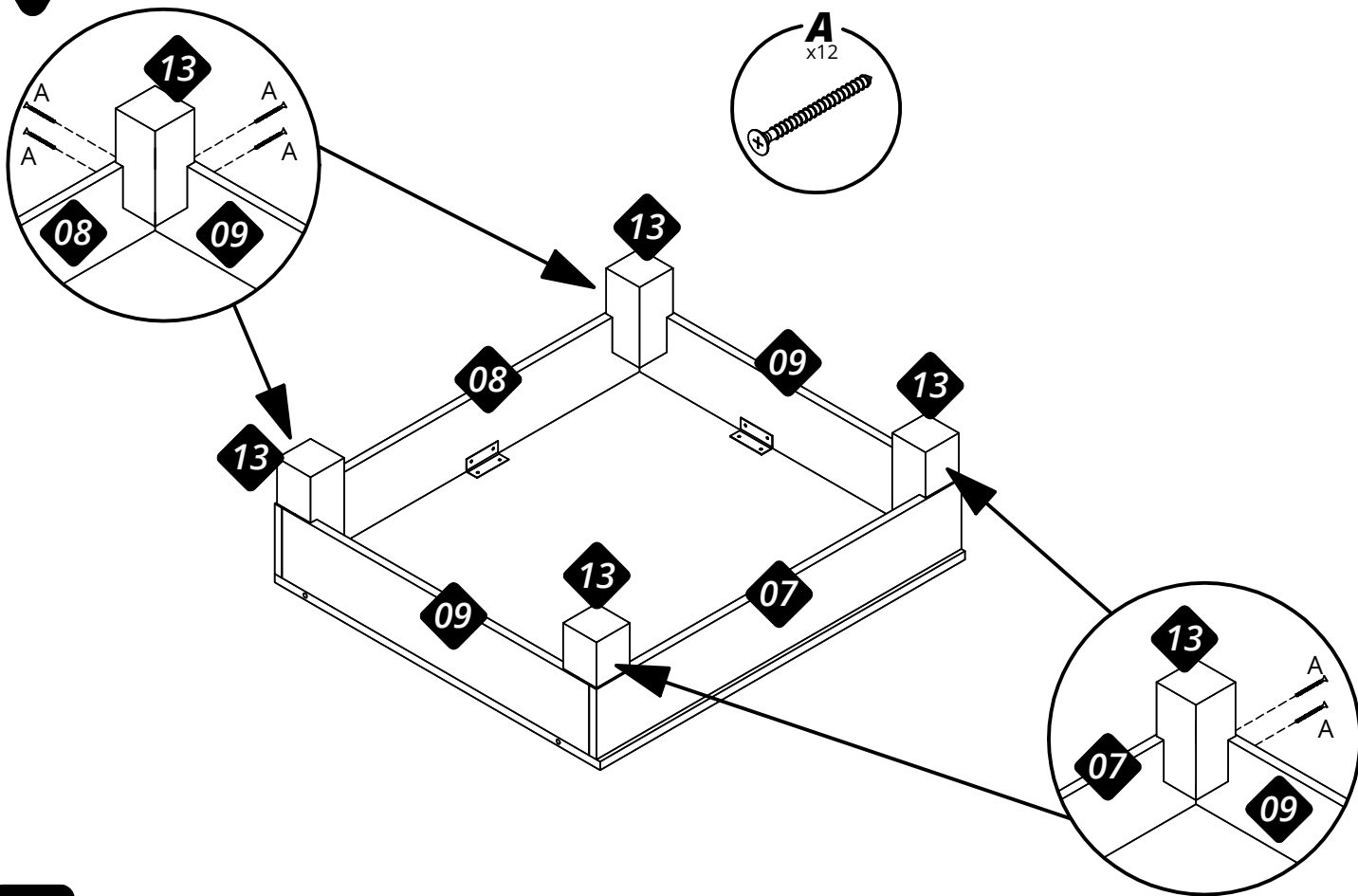

08

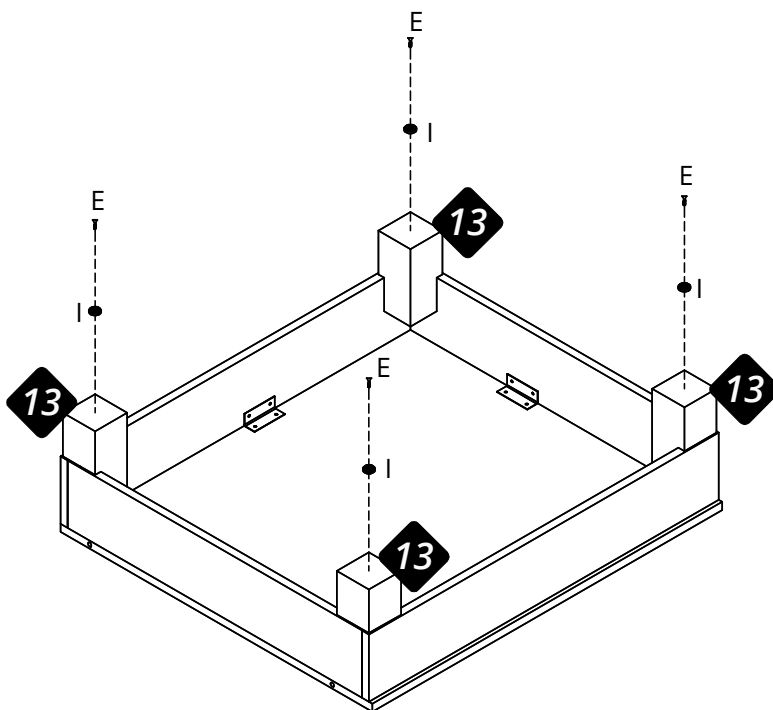
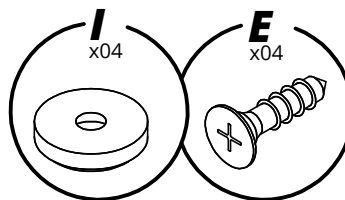

09

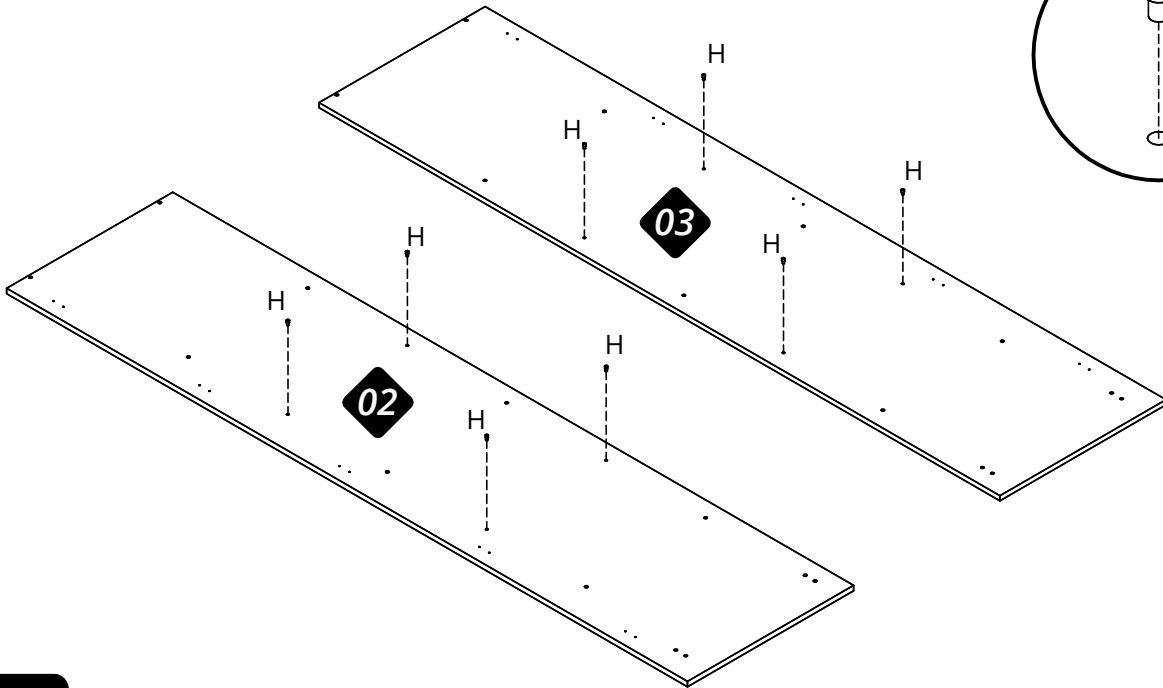
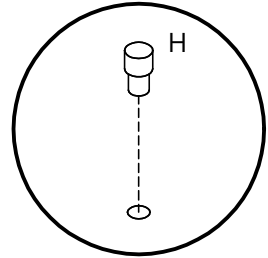
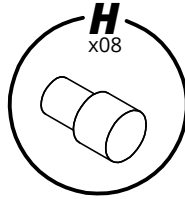

10

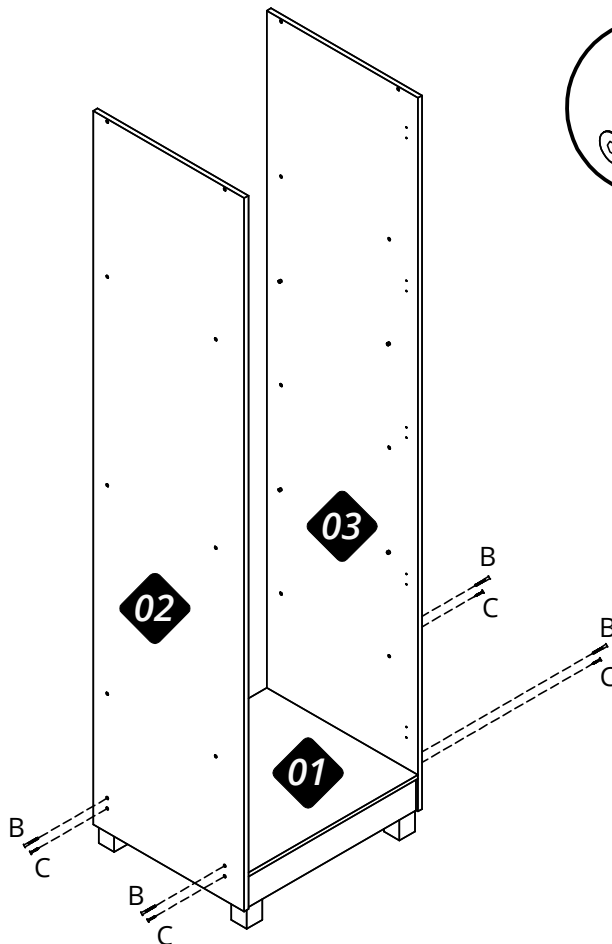
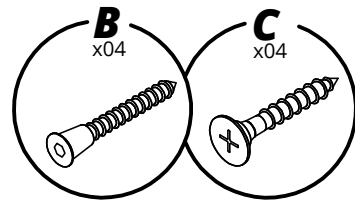

11

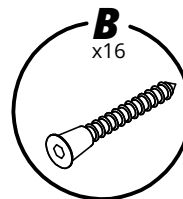
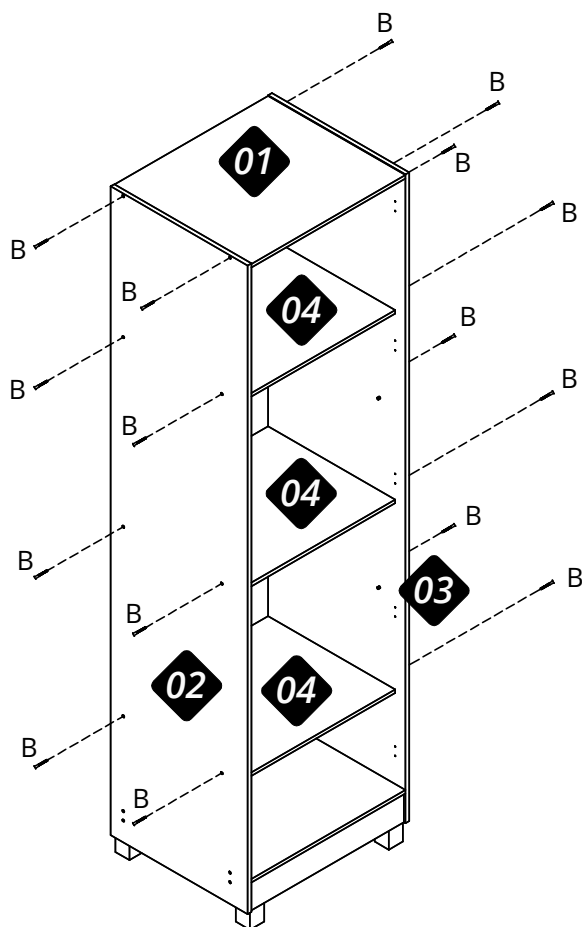

12

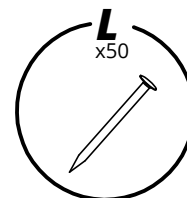
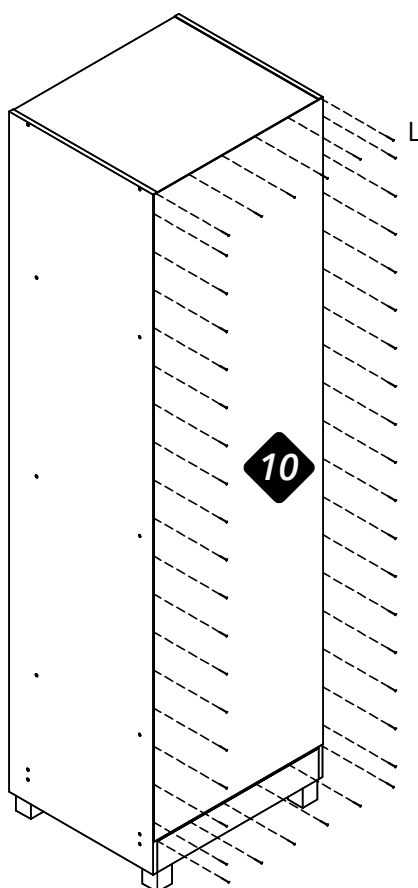

13

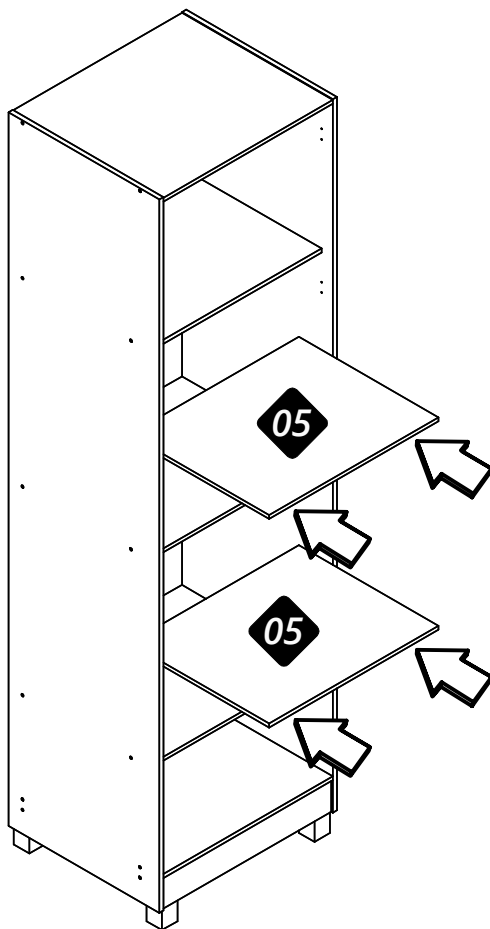

14

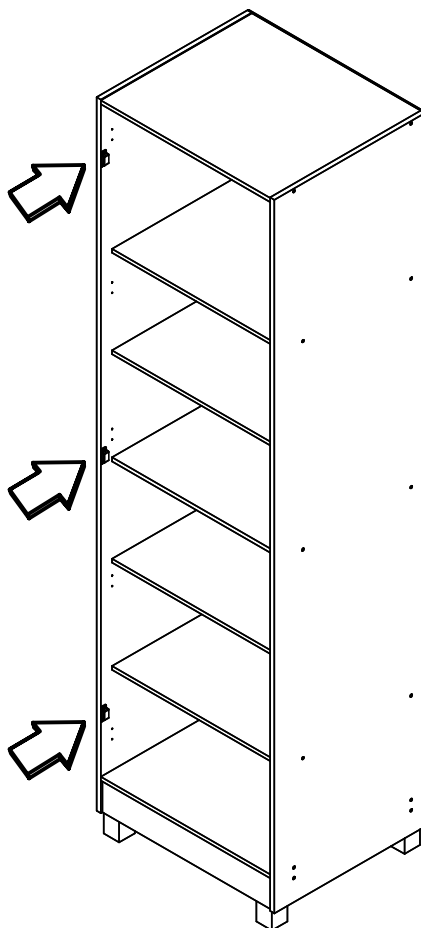
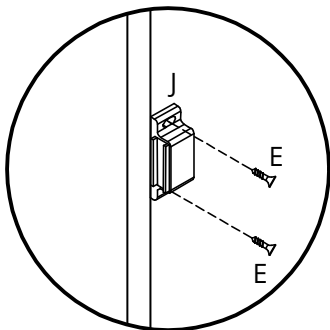
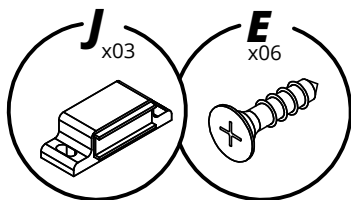

15

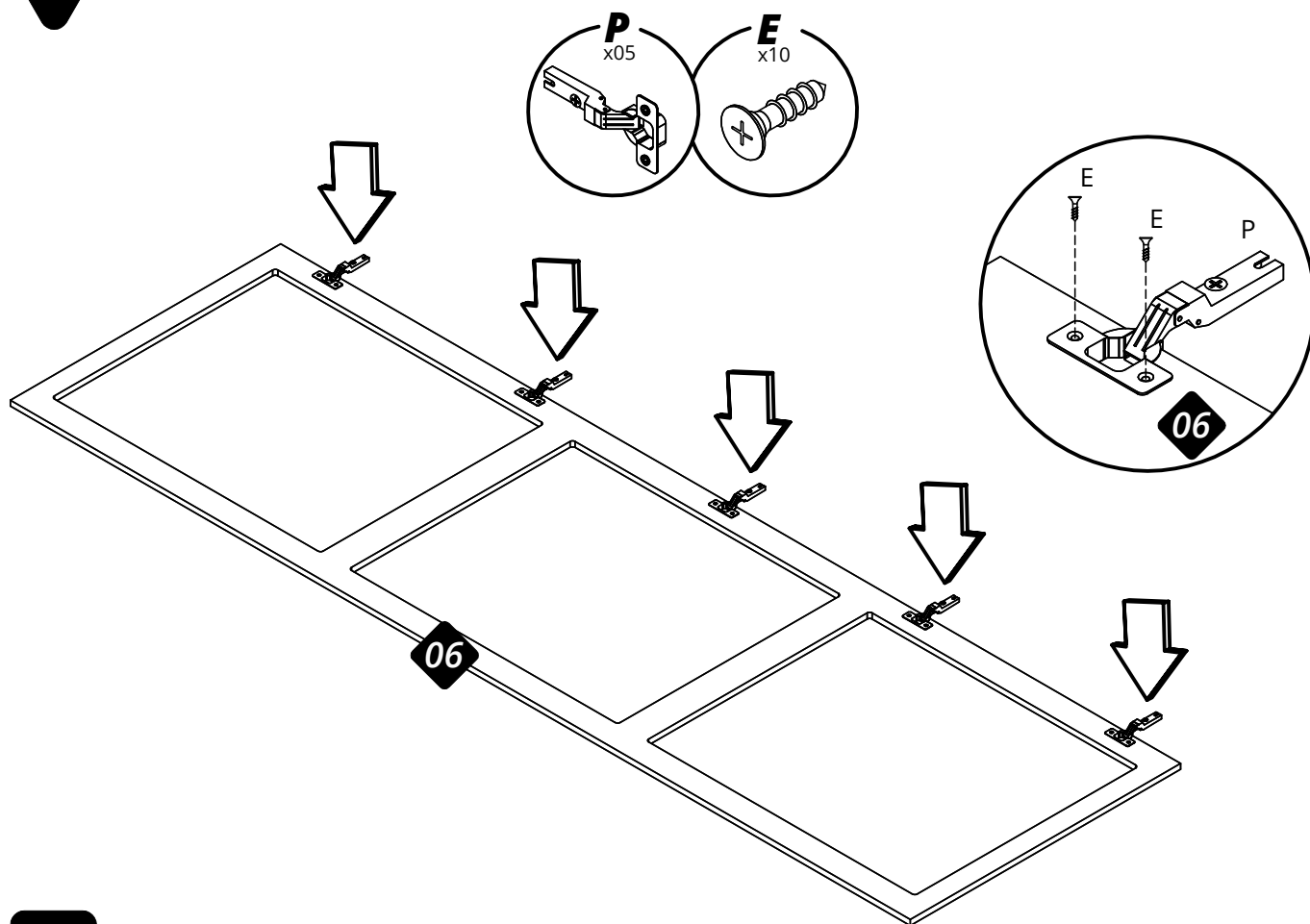

16

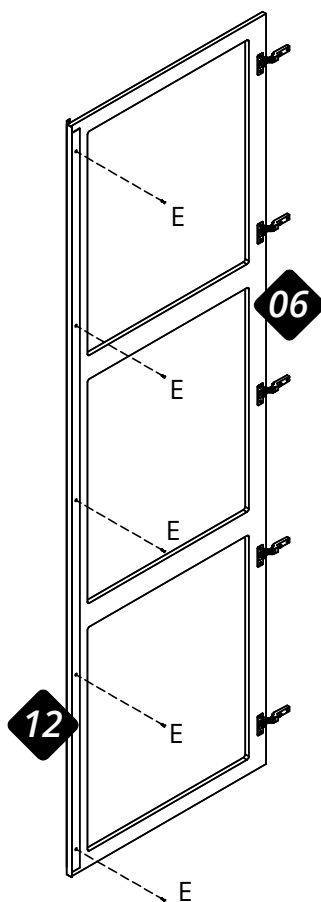
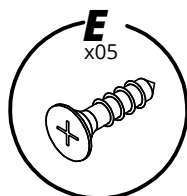

- Detalhe da fixação do Puxador.

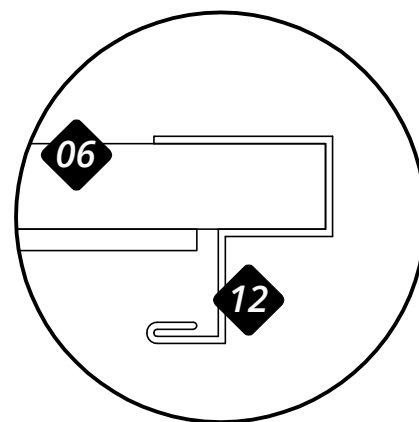

17

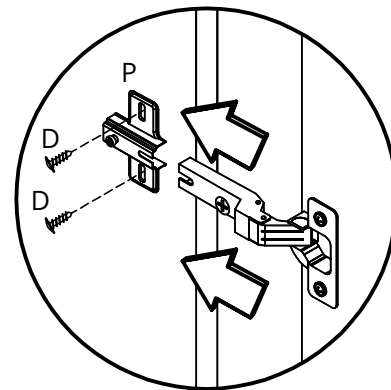
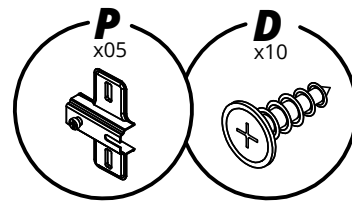
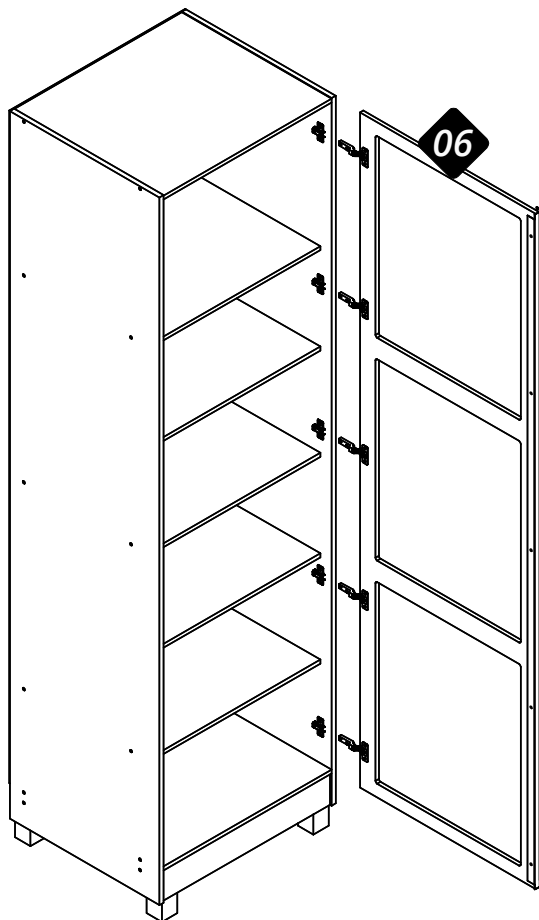

18

