

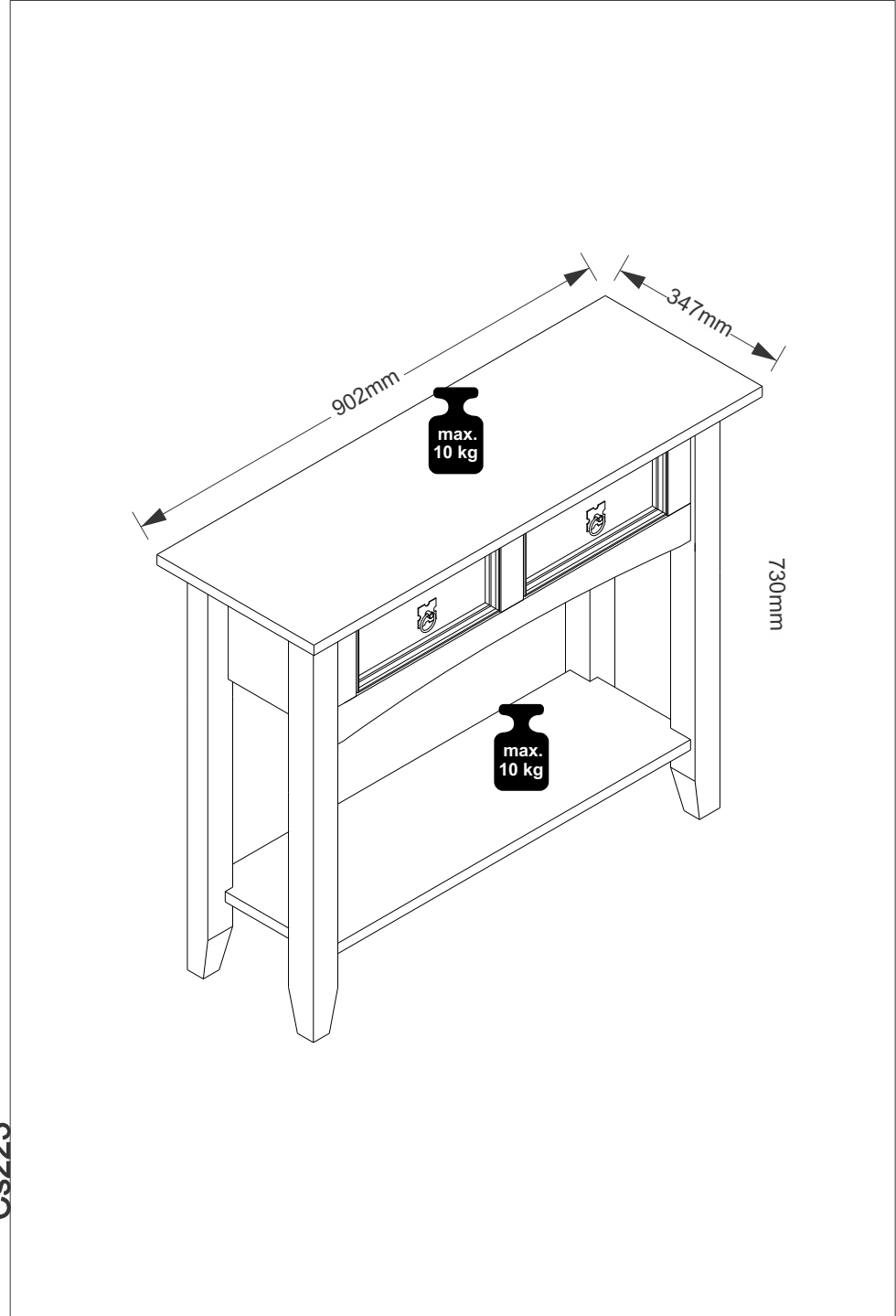



Cs223





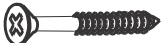
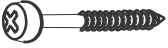

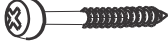
A x 36 Cod.3900  Cavilha Ø8x30mm	B x 16 Cod.6200  Parafuso Ø3,5x25mm Phillips	C x 26 Cod.1079  Parafuso Ø4,0x35mm Cabeça Panela
D x 2 Cod.6106  Puxador Santa Fé	E x 2 Cod.7335  Parafuso Ø3/16x3/4mm ZP	F x 4 Cod.52  Parafuso Ø4,5x50mm Cabeça Panela

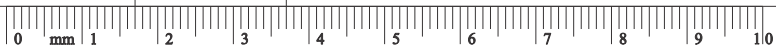
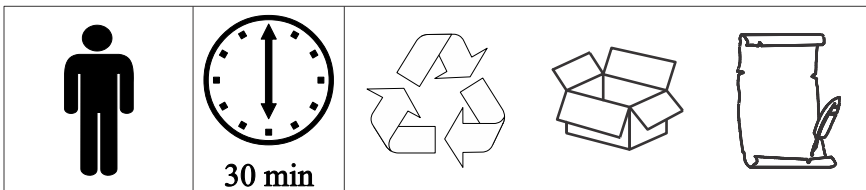
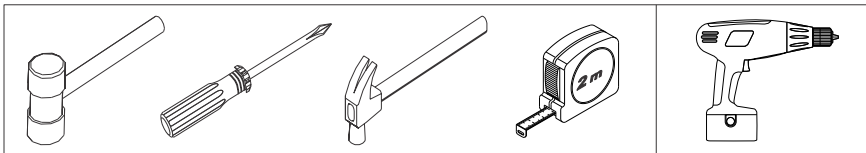
LISTA DE PEÇAS

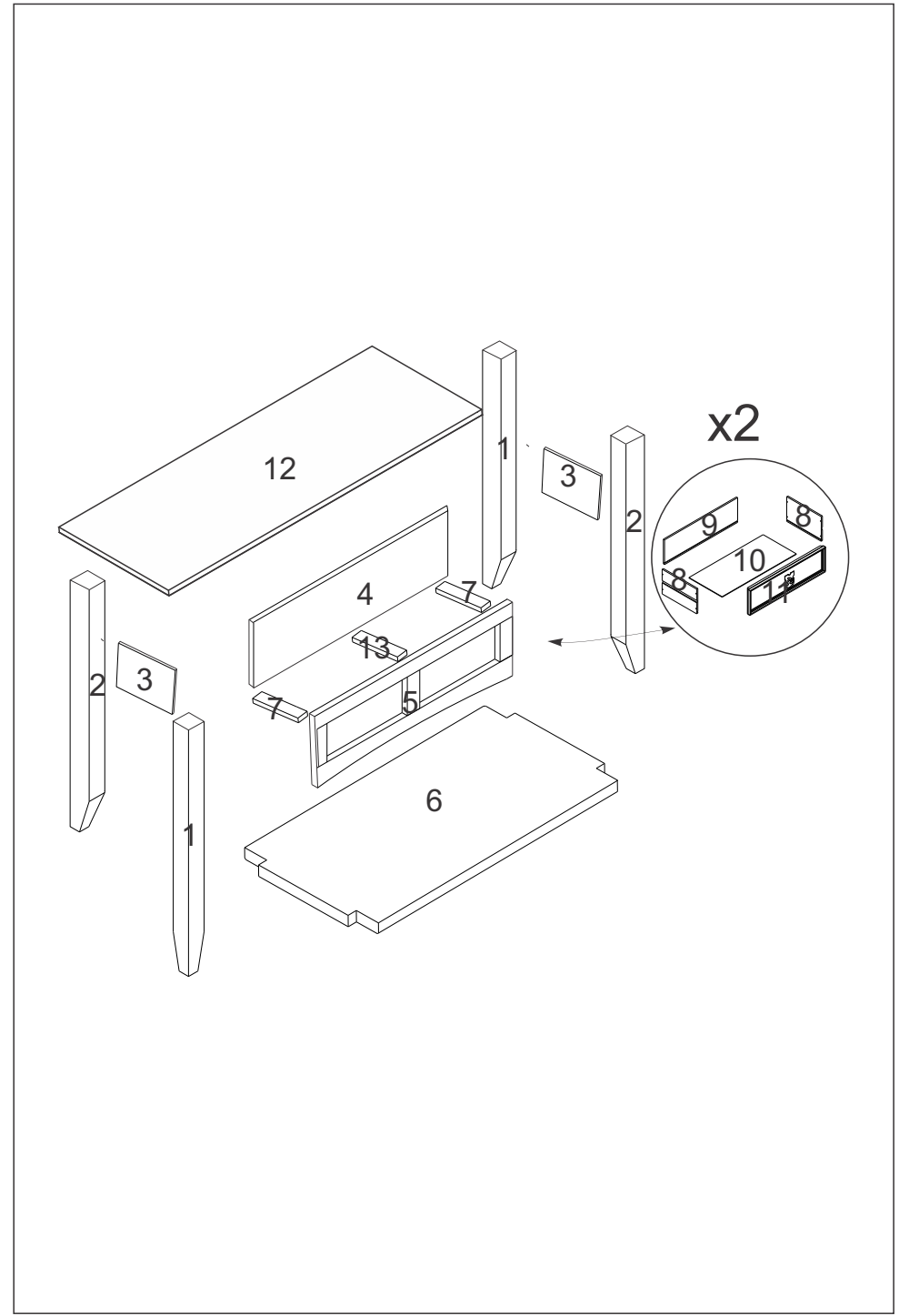
Nº PEÇA	COD.	DESCRIÇÃO	QTD	DIMENSÕES (mm)			PESO UND
				COMP	LARG	ESP	
1	6699	Pé Direito Aparador	2	0,7150	0,0460	0,0460	0,693
2	6700	Pé Esquerdo Aparador	2	0,7150	0,0460	0,0460	0,693
3	6685	Lateral Aparador	2	0,1620	0,2100	0,0150	0,206
4	6687	Painel Traseiro	1	0,7160	0,2100	0,0150	1,024
5	6696	Armação Frontal	1	0,7160	0,2300	0,0150	0,717
6	6684	Base	1	0,7480	0,2440	0,0150	1,237
7	6692	Corrediça Lateral	2	0,1900	0,0530	0,0160	0,075
8	8832	Lateral de Gaveta	2	0,1750	0,1080	0,0130	0,093
9	8831	Costa de Gaveta	1	0,2580	0,1080	0,0130	0,187
10	8830	Chapa de Gaveta	1	0,2650	0,1620	0,0030	0,108
11	6688	Frete de Gaveta	1	0,2840	0,1120	0,0150	0,307
12	6683	Tampo	1	0,9020	0,3470	0,0150	2,54





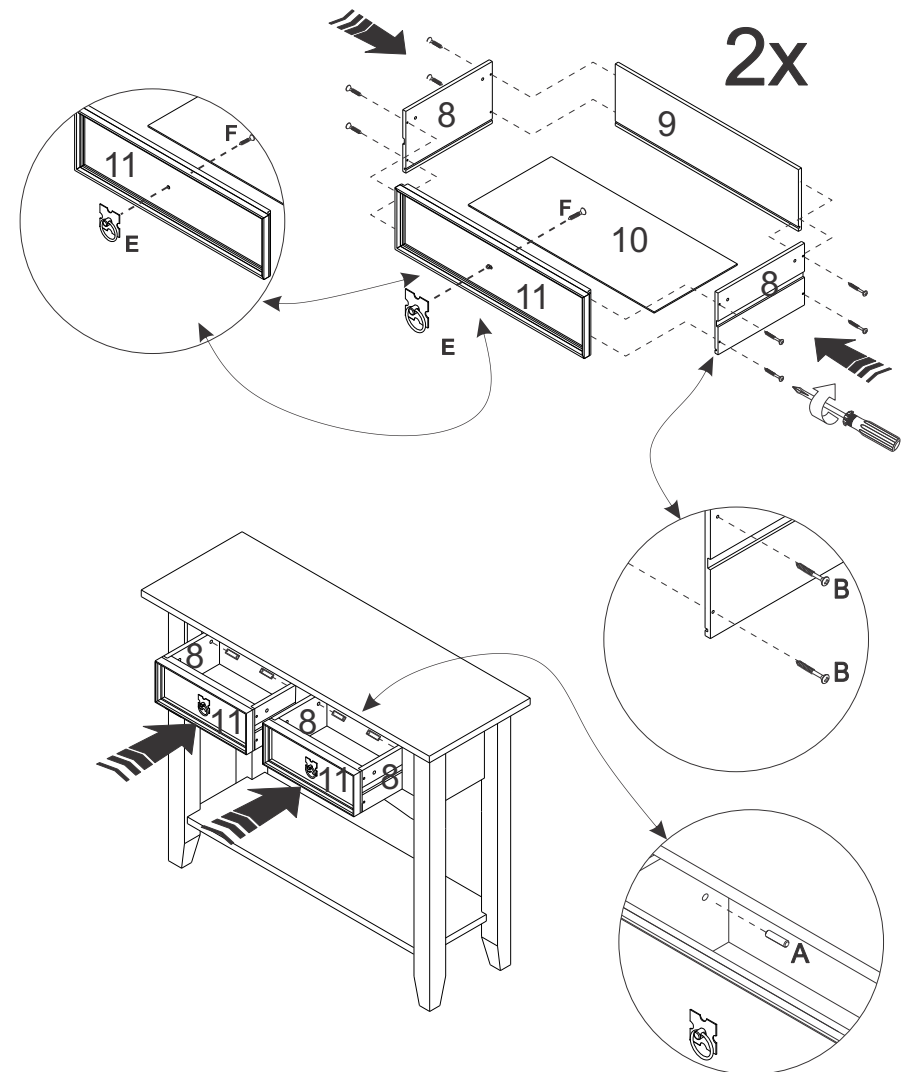

Ax4	Bx16	Dx2	Ex2
			
Ø8x30mm	Ø3,5x25mm		Ø3,16x34mm



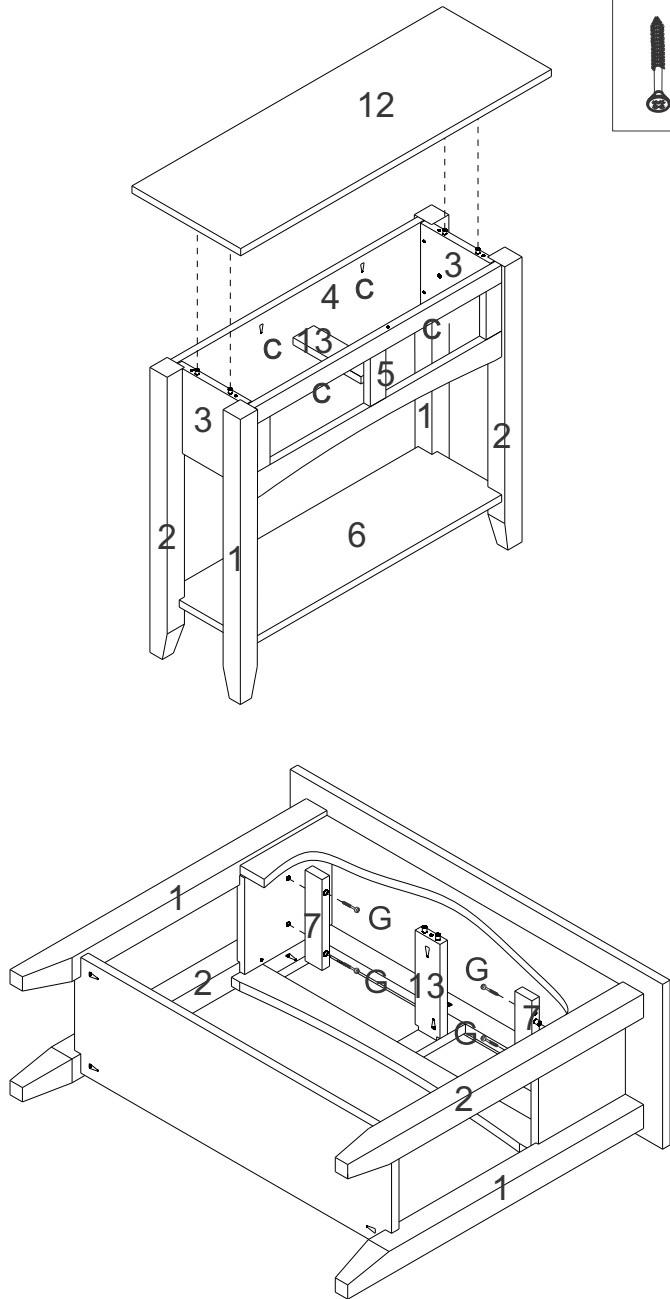

4

Fx4	Cx4
	
Ø4,5x50mm	Ø4,0x35mm



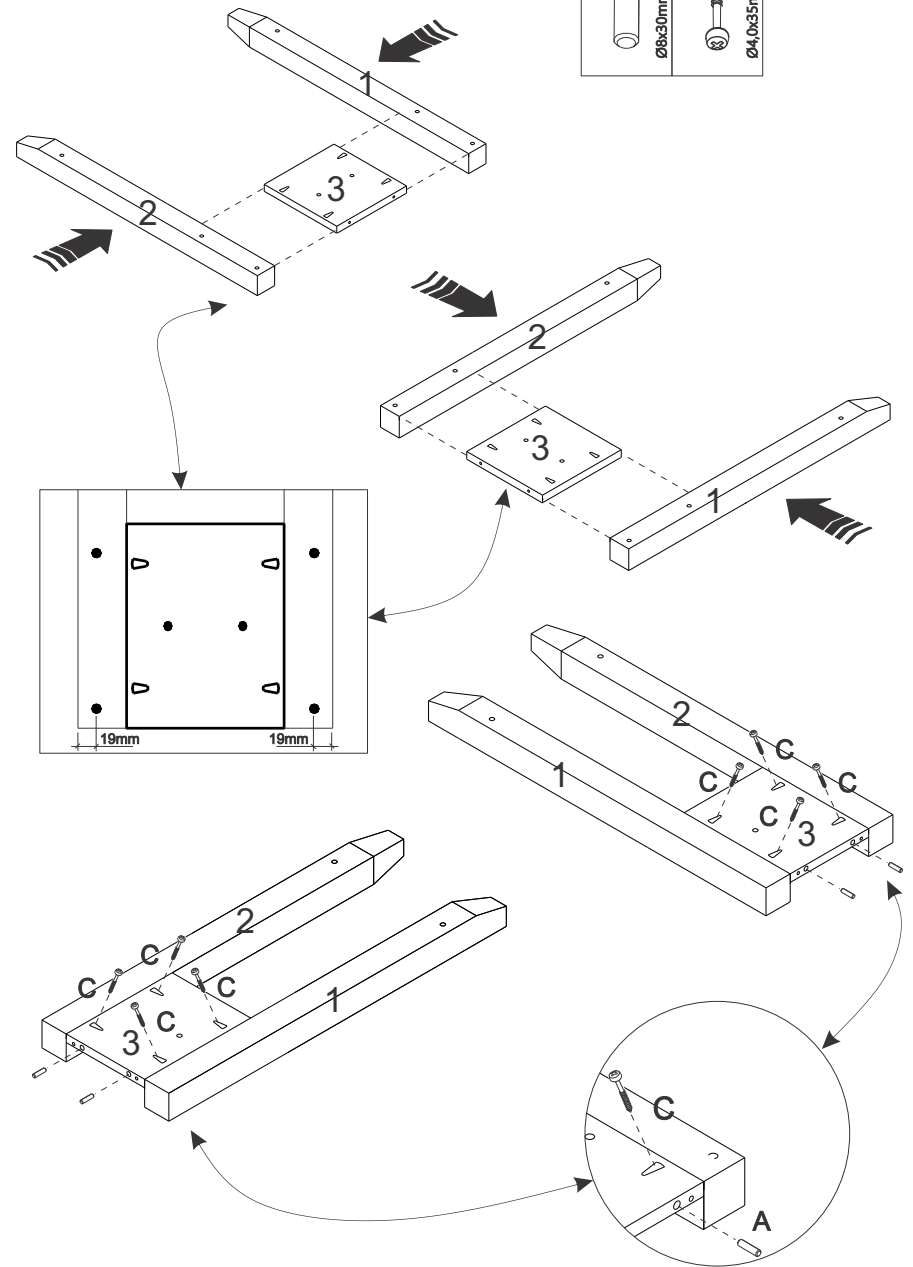

1

Ax4	Cx8
	
Ø6x30mm	Ø4,0x35mm



2

Ax15	Cx5
	
∅6x30mm	∅4,0x35mm

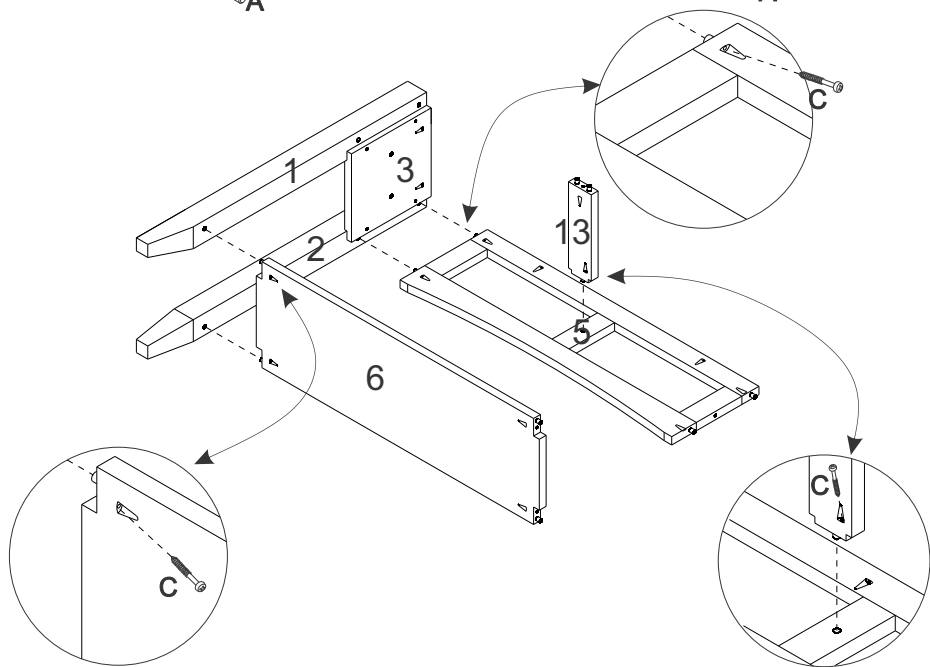
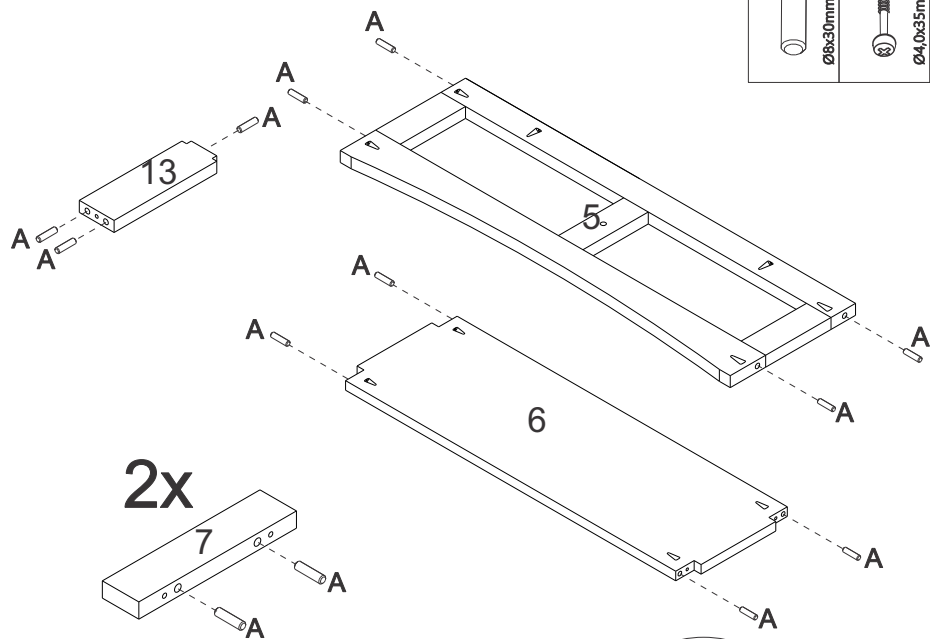

Cx9



3

