

EAMES / BOTONÊ OFFICE

CADEIRA

CHAIR

SILLA

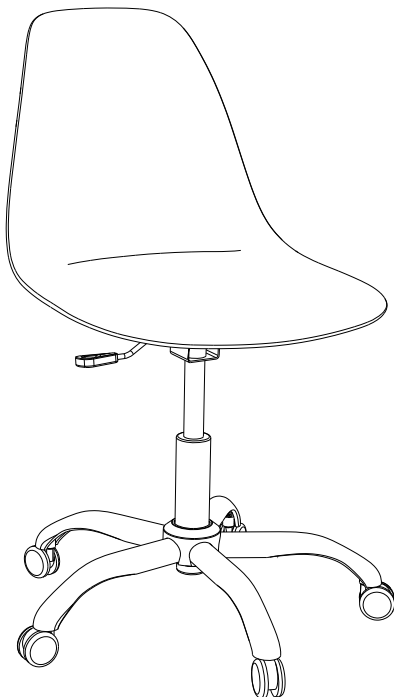

Seat&Co

INDÚSTRIA DE MÓVEIS

Utilizar a régua abaixo para medir os componentes.
Use the ruler below to measure the components.
Usa la regla de abajo para medir los componentes.



medidas em mm
measurements in mm
medidas en mm

Composição do Produto

Product Composition
Composición del Producto

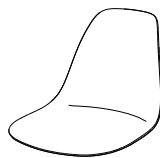

1 Concha (1x)
Seat (1x)

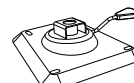

2 Flange (1x)
Metal salver (1x)



3 Estrela (1x)
Metal 5 foot legs (1x)
Estrela (1x)



4 Rodizio Giratório (5x)
Plastic caster (5x)
Rueda giratório (5x)



5 Coluna a gás (1x)
Gas lift (1x)
Columna de gas (1x)

Componentes de Montagem

Assembly Components
Composición del Producto

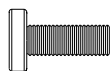

A- Parafuso allen
Allen screw
Tornillo Allen
M6x15 (4x)



B- Arruela lisa
Flat washer
Arandela plana
M6 (4x)



C- Arruela de Pressão
Pressure Washer
Arandela de presión
M6 (4x)



D- Chave "L" Hexagonal
Hexagonal "L" Key
Llave "L" Hexagonal
M6 (1x)

Recomendações:

- 1 - Leia atentamente toda a instrução antes de iniciar a montagem.
- 2 - A montagem do produto deverá ser feita em uma superfície limpa e plana. Aconselhamos utilizar a própria embalagem para forrar o chão a fim de não danificar o produto.
- 3 - Reservar área livre para montagem do produto.
- 4 - Evite jogar-se ou ficar em pé sobre a cadeira.

Recommendations:

- 1- Read the entire instruction carefully before starting the assembly.
- 2- The product must be mounted on a clean and flat surface. We recommend using the packaging itself to cover the floor in order not to damage the product.
- 3- Reserve a free area to assembly the product.
- 4 - Avoid throwing yourself or standing on the chair.

Recomendaciones:

- 1 - Lea atentamente toda la instrucción antes de iniciar el montaje.
- 2 - El montaje del producto deberá ser hecho en una superficie limpia y plana. Aconsejamos utilizar el propio embalaje para cubrir el piso a fin de no dañar el producto.
- 3 - Reservar una área libre para el montaje del producto.
- 4 - Evite encorvarse o pararse en la silla.



-Pessoas necessárias para montar o produto
-People needed to assemble the product
-Personas necesarias para montar el producto



-Tempo de montagem aproximado
-Approximate assembly time
-Tiempo aproximado de montaje



fácil

Grau de dificuldade
Difficulty level
Nivel de dificultad



-Não utilizar químicos ou abrasivos na limpeza, evitar batidas e contato com objetos cortantes.
-Do not use chemicals or abrasives for cleaning, avoid knocks and contact with sharp objects.
-No utilice químicos ni abrasivos para la limpieza, evite los golpes y contacto con objetos afilados.



-Pano umedecido com água seguido de pano seco.
-Cloth moistened with water followed by dry cloth
-Paño humedecido con agua seguido de paño seco.



-Capacidade máxima suportável, distribuída uniformemente.
-Maximum bearable capacity, evenly distributed.
-Maxima capacidad soportable, distribuída uniformemente.

1 Montagem Assembly Montaje

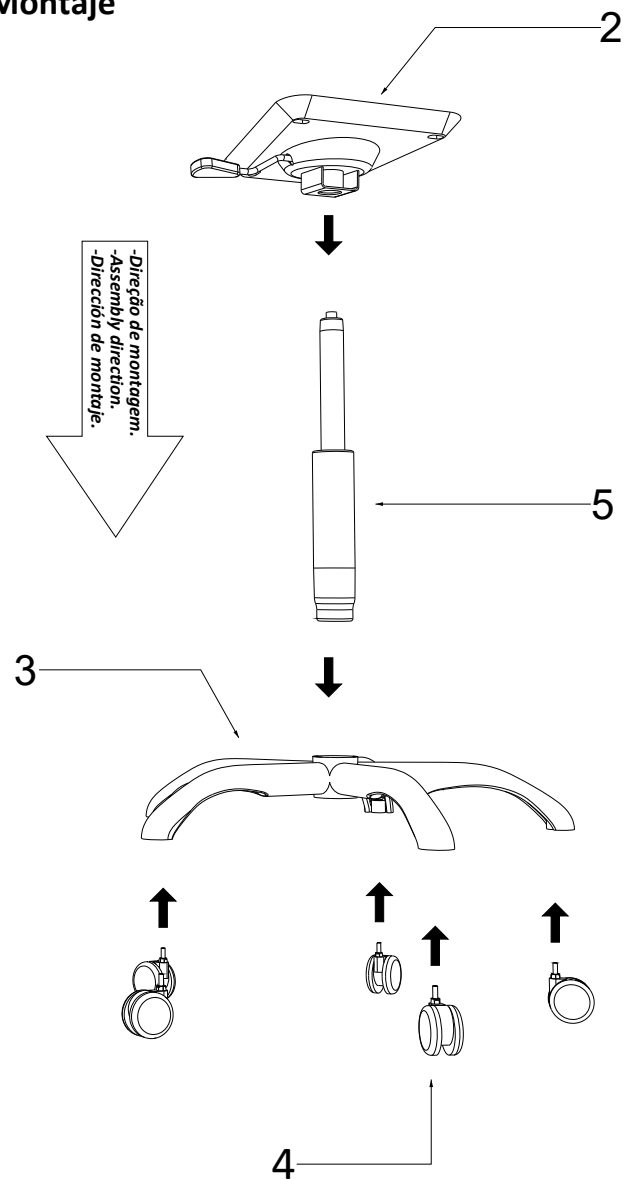

- Item 5 - Encaixe o pino do rodizio no alojamento circular por pressão.
- Item 5 - Fit the caster pin in the circular housing by putting pressure on it.
- Ítem 5 - Montar el pasador de la rueda en la carcasa circular a presión.

2

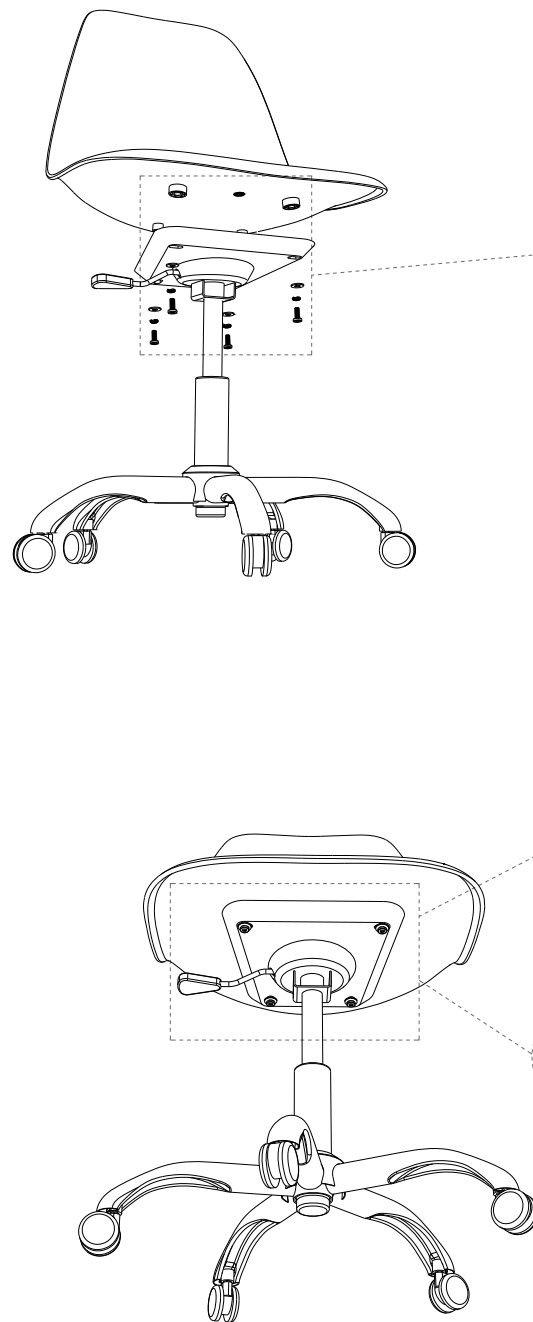

Primeiro passo: fixar parafuso A
 Segundo passo: fixar parafuso B
 Terceiro passo: fixar parafuso C
 Quarto passo: fixar parafuso D

First step: place screw A
 Second step: place screw B
 Third step: place screw C
 Fourth step: place screw D

Primer paso: fijar el tornillo A
 Segundo paso: fijar el tornillo B
 Tercer paso: fijar el tornillo C
 Cuarto paso: fijar el tornillo D

-Após posicionar todos os componentes, apertar totalmente os parafusos
 -After placing all the components, fully tighten the screws
 -Después de colocar todos los componentes, apretar completamente los tornillos

Seat&Co

INDÚSTRIA DE MÓVEIS