

PLACA&PONTO

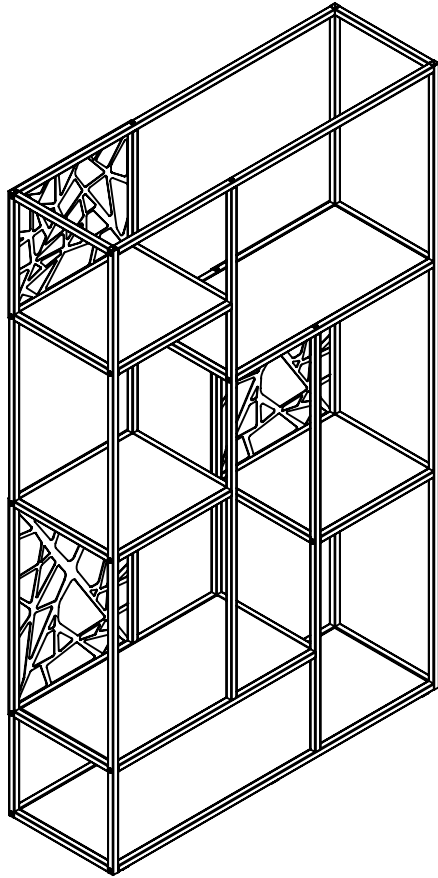

D°\$) + !'9 GH5 BH9 '5 @H5 '
@B<5 '89 GH5 EI 9 G

\$%

PLACA&PONTO

J-GH5 '9LD@8-85

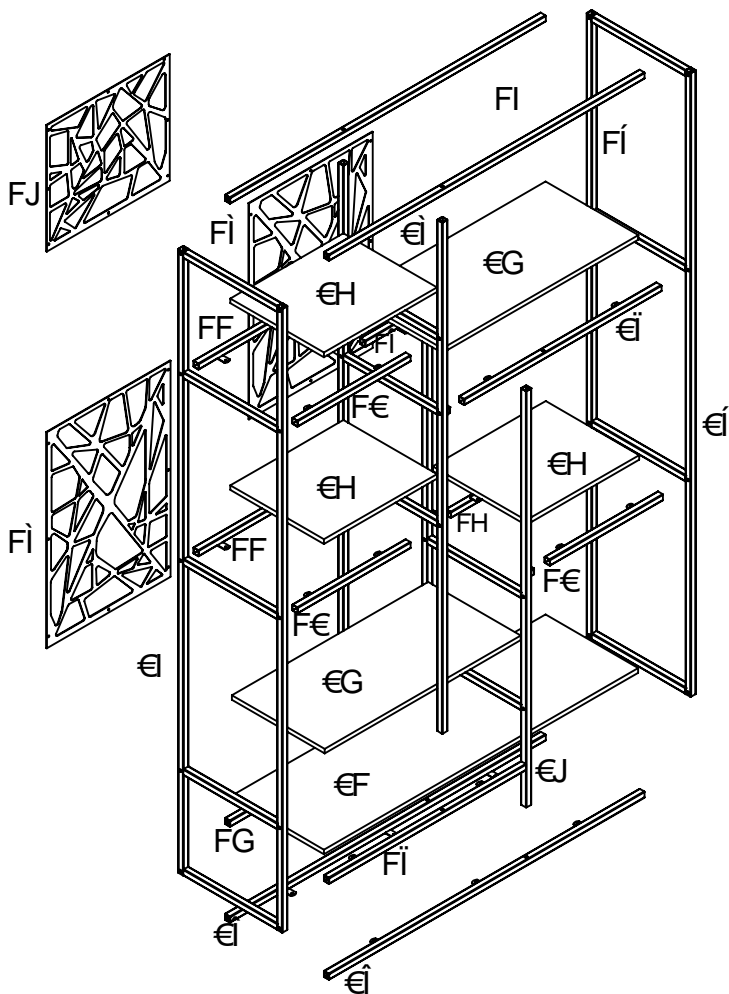

\$'

PLACA&PONTO

\$%

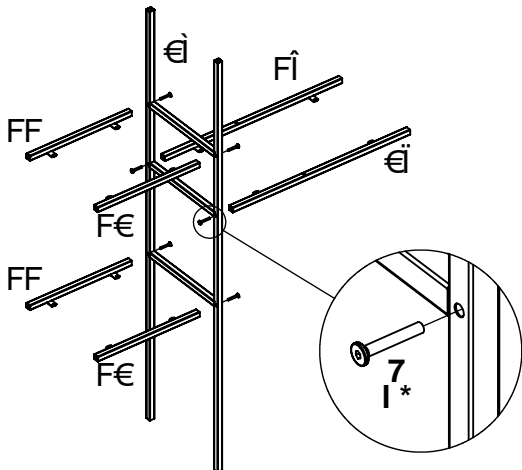

OUBAV a à [A&&@^CH^) AODÁ aæ •^A•A aæ • [•AODÁ aæAaA •A à [•A [A
 !^~ aal [A^) daE
 OUBAV a à [AaAa^CH^) AODÁa ; a [A [•A^] [•AODÁ aæaæ •^* i aA [•A a [•A A
 { a& [A^) daE
 OUBAV a * A@CH^) A^ AODÁ a^, A a@A [| AODÁ A^& i A@A a^ A a@A) c i A
 i aæ ^E

\$&

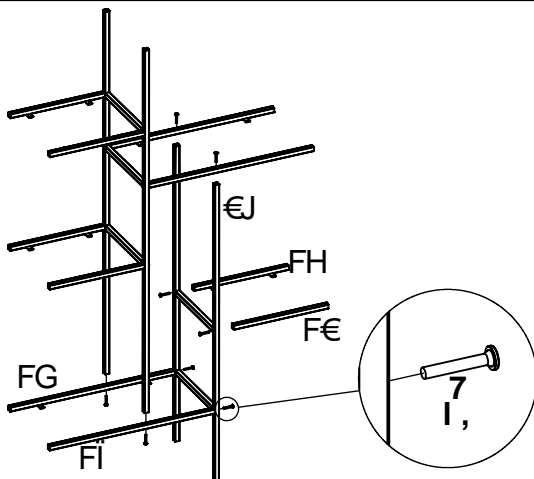

OUBAV a à [A&&@^CH^) AODÁ aæ •^A•A aæ • [•AODÁ aæAaA •A à [•A A A
 •^*) a [A^ aal [A^) daE A^ ca c A [•A a [•E
 OUBAV a à [AaAa^CH^) AODÁa ; a [A [•A^] [•AODÁ aæaæ •^* i aA [•A a [•A A A
 •^*) a [A a& [A^) daE A^ d A A A •A a [•E
 OUBAV a * A@CH^) A^ AODÁ a^, A a@A [| AODÁ A^& i A@A a^ A a@A & } a A
 &) c i A aæ ^ A A a@A^ c A a@A a^ E

\$*

PLACA&PONTO

\$)

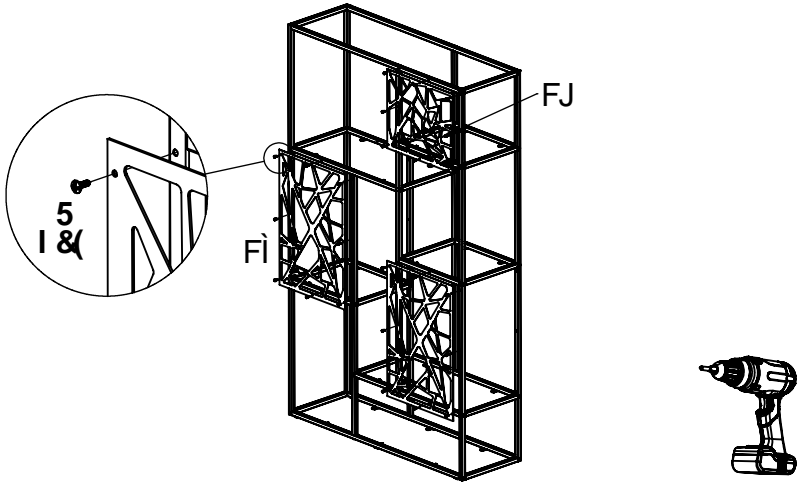

ÓÜÈÁÚææ·^Á·Á ææ·|·ÁÇÈÁ ææÁæÁæ Áæ|æ Áæ^áæ Áæ·Á æ à|·ÁæÁ·d`c|æÈ
 ÓÜÈÁÇÈ|) ã|Á|·Á|) ã|·ÁÇÈÁ ææÁæÁæ Á æ çæ|æ Áææ^|æ ÁæÁ|·Á æ à|·Áæ^|Áæ çæ|È
 Ò·ÈÁÚ&^, Áæ ÁæÁæ&^, ·ÁÇÈÁ Á^&^|Áæ@Á^æÁ&^|·Áæ Áæ@Áæ Áæ^áæÈ

\$(

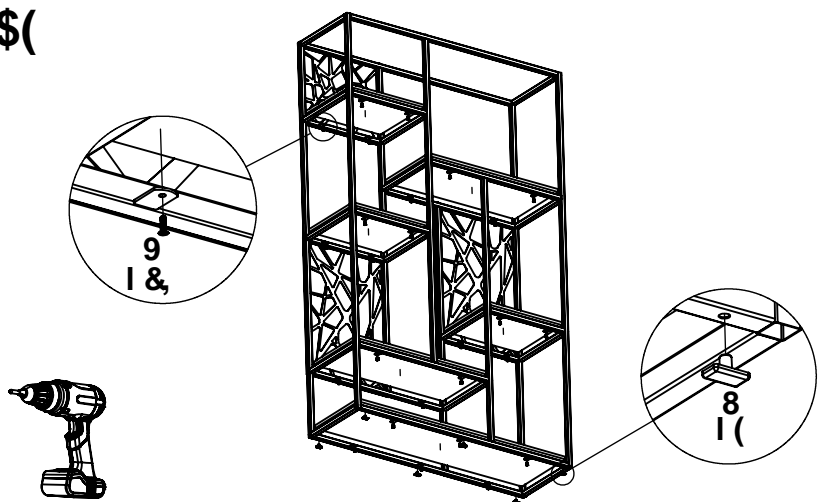

ÓÜÈÁÚææ·^Á·Á ææ·|·ÁÇÈÁ ææÁæÁæ Áæ|æ^|ææ ÁæÁ·çæ ç·ÁÁ) &ææ^Áæ Á
 |.|) ç·áæ ÁÇÈÁ ææÁæÈ
 ÓÜÈÁÇÈ|) ã|Á|·Á|) ã|·ÁÇÈÁ ææÁæÁæ Á·Á·çæ ç·ÁæÁæ·çæ ç·ÈæÁÁ) &ææÁ|·Á
 ^æd^| [·ÁÇÈÁ) ÁæÁæ^È
 Ò·ÈÁÚ&^, Áæ ÁæÁæ&^, ·ÁÇÈÁ Á^&^|Áæ@Á^|ç·Áæ Áæ@Áæ [| \ &ææ^Áæ áÁæ@Áæ·Á
 ÇÈÁæ ç ÁæÁæ^È

\$,

