

# MANUAL DE MONTAGEM / ASSEMBLY INSTRUCTIONS / PLANO DE ARMADO

**Antes de montar o móvel, leia com atenção o manual de montagem!**  
**Before assembling the furniture, carefully read the assembly instructions!**  
**Antes de armar el mueble, lea con atención el manual de ensamble!**



**Ref.: 3508**

**genialflex**  
ambientes incríveis para todos

Parabéns! Você comprou um produto de excelente qualidade, fabricado com chapa de madeira de MDP ou MDF, extraída de florestas renováveis. Possui alta resistência e design atual.

Congratulations! You have purchased a product of excellent quality, made from MDP or MDF wood veneer, extracted from renewable forests. It has high strength and current design.

Felicitaciones! Usted compró a un producto de excelente calidad, fabricado con placa de madera de MDP o MDF, proveniente de florestas renovables. Tiene alta resistencia y diseño actual.



**ATENÇÃO**  
**ATTENTION**  
**ATENCIÓN**

- 1)** Verifique todas as peças antes de começar a montagem.  
Check all parts before starting assembly.  
Verifique todas las partes antes de empezar el armado.
- 2)** Ao começar a montagem, não apoie as peças na parede.  
When starting the assembly, do not support the parts on the wall.  
Al empezar el armado, no apoyes las partes en la pared.
- 3)** Ao colocar as peças e ferragens de lado, cuidado para não perde-las.  
When placing parts and hardware aside, be careful not to lose them.  
Al poner las piezas y herrages a parte, cuidado para no dañarlas.
- 4)** O móvel deve ser montado no chão, para isso, use a própria caixa para proteger e não danificar o piso.  
The furniture must be mounted on the floor, to do this, use the box itself to protect and not damage the floor.  
El mueble suele ser armado al piso, para eso, use la propia caja para protegerlo y no dañar al piso.
- 5)** Comece a montagem seguindo as instruções passo a passo.  
Begin assembly by following the step-by-step instructions.  
Comience el armado siguiendo la instrucciones paso a paso.
- 6)** É de responsabilidade do montador seguir as intruções desse manual, que são fundamentais para a estrutura do móvel.  
It's the assembler's responsibility to follow the instructions in this manual, which are fundamental to the structure of the furniture.  
Es de responsabilidad del armador seguir las instrucciones de este manual, que son fundamentales para la estructura del mueble.

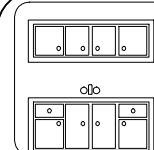

**CUIDADOS**  
**CARE**  
**CUIDADO**

- 1)** A conservação e limpeza deve ser feita com um pano levemente umedecido com água.  
Care and cleaning should be done with a cloth slightly moistened with water.  
La conservación y limpieza debe ser hecha con un trapo levemente humedecido en agua.
- 2)** Não use produtos abrasivos, como saponáceo, detergentes e esponja de aço.  
Do not use abrasive products, such as soap, detergents and steel sponge.  
No use productos abrasivos, como saponáceo, detergentes y esponja de acero.
- 3)** Não use cera ou óleo para dar brilho ao móvel.  
Do not use wax or oil to shine the furniture.  
No use cera o aceites para darle brillo al mueble.
- 4)** Não expor o móvel a interpéries e nem ao calor excessivo.  
Do not expose the furniture to weather or excessive heat.  
No exponer el mueble a interperies ni al calor excesivo.
- 5)** Ao terminar a montagem, limpe o ambiente e o móvel.  
When the assembly is finished, clean the room and the furniture.  
Al terminar el armado, limpie al ambiente y al mueble.

## FERRAMENTAS / TOOLS / HERRAMIENTAS



MARTELO  
HAMMER  
MARTILLO



NAO RECOMENDAVEL  
NOT ADVISABLE  
NO RECOMENDABLE

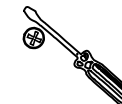

CHAVE PHILLIPS  
PHILLIPS SCREWDRIVER  
LLAVE PHILLIPS



MARTELO DE BORRACHA  
RUBBER HAMMER  
MARTILLO GOMA









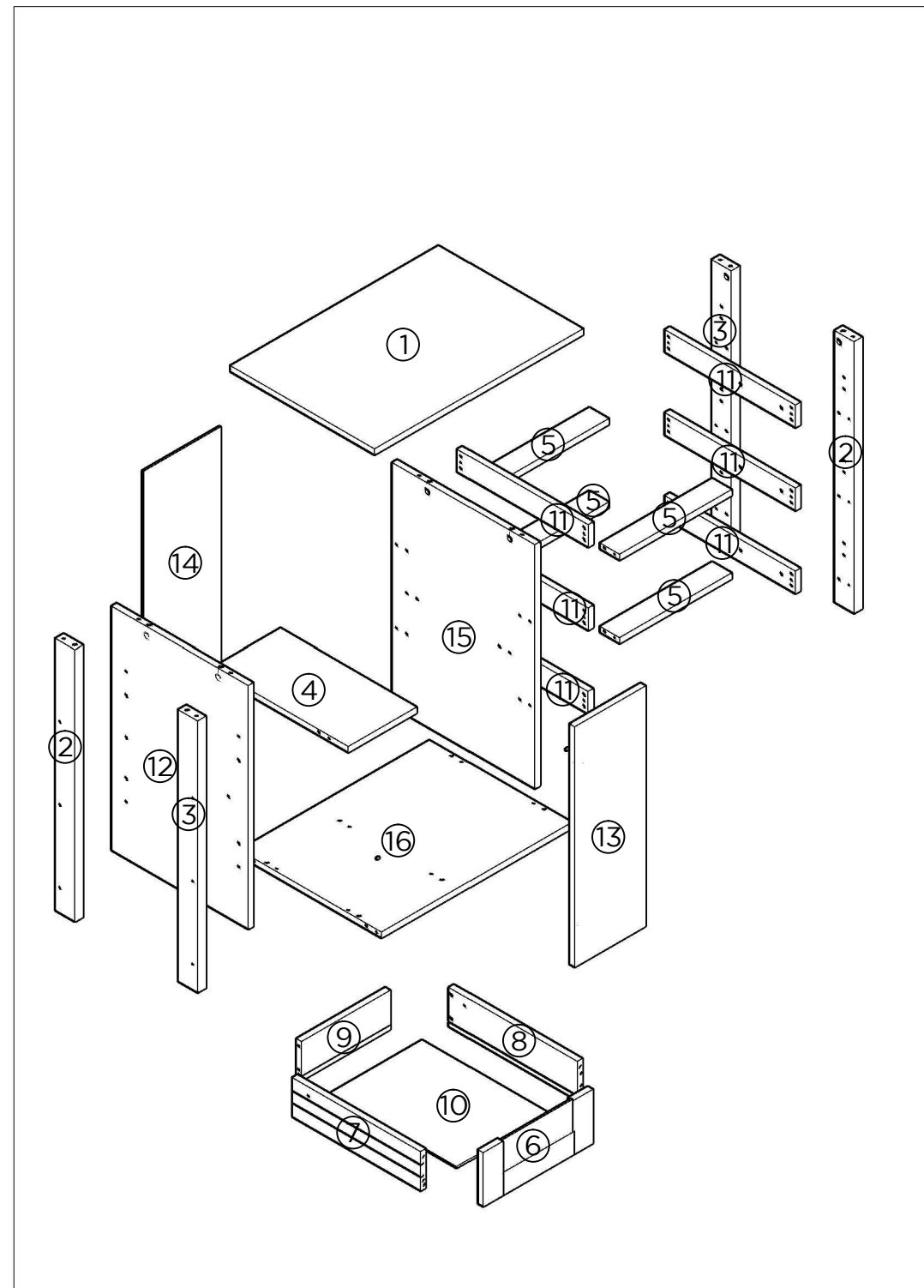













TRENA  
MEASURING TAP  
CINTA MÉTRICA

**PEÇAS / PARTS / PIEZAS**

<b>Nº No Num</b>	<b>DESCRIÇÃO DESCRIPTION DESCRIPCIÓN</b>	<b>QTD QTY CANT</b>
1	TAMPO TOP TABLERO	1
2	PÉ ESQUERDA LEFT FEET PIE IZQUIERDO	2
3	PÉ DIREITO RIGHT PIE PIE DERECHO	2
4	PRATELEIRA PLATE PANEL REPISA	1
5	TRAVESSA PLATE TRAVESAÑO	4
6	FRENTE DE GAVETA DRAWER FRONT FRENTE DEL CAJÓN	3
7	LATERAL ESQ DE GAVETA LEFT DRAWER SIDE LATERAL IZQUIERDO DEL CAJÓN	3
8	LATERAL DIR DE GAVETA RIGHT DRAWER SIDE LATERAL DERECHO DEL CAJÓN	3
9	COSTA DE GAVETA DRAWER BACK TRASERO DEL CAJÓN	3
10	FUNDO DE GAVETA DRAWER BOTTOM PANEL FONDO DEL CAJÓN	3
11	TRAVESSA CORREDIÇA SLIDING PLATE TRAVESAÑO DESLIZANTE	6
12	LATERAL ESQUERDA LEFT SIDE PANEL LATERAL IZQUIERDA	1
13	PORTA DOOR PUERTA	1
14	COSTA BACK PANEL TRASERO	1
15	DIVISORIA DIVISION DIVISIÓN	1
16	BASE BOTTOM BASE	1



**FERRAGENS / HARDWARE / HERRAJES**

<b>CÓD CODE COD</b>	<b>DESCRIÇÃO DESCRIPTION DESCRIPCIÓN</b>	<b>QTD QTY CANT</b>
A	 CAVILHA 6X30mm WOODEN DOWEL 6X30mm TARUGO 6x30mm	28
B	 CAVILHA 6X20mm WOODEN DOWEL 6X20mm TARUGO 6x20mm	22
C	 CAVILHA ESCAMADA PLASTIC DOWEL TARUGO ESCAMADO	24
D	 PARAFUSO MINIFIX MINIFIX SCREW TORNILLO MINIFIX	6
E	 PARAFUSO 3,5X50mm SCREW 3,5X50mm TORNILLO 3,5X50mm	20
F	 PARAFUSO 3,5X25mm SCREW 3,5X25mm TORNILLO 3,5X25mm	16
G	 TAMBOR MINIFIX MINIFIX DRUM TAMBOR MINIFIX	6
H	 FIXADOR CORREDIÇA SLIDE FIXER FIJADOR CORREDERA	12
J	 PARAFUSO 3,5X25mm SCREW 3,5X25mm TORNILLO 3,5X25mm	2
K	 CORREDIÇA SLIDE CORREDERA	6
L	 PREGO NAIL CLAVO	18
M	 RODIZIO/ 2 RODIZIO COM FREIO WHELL/ 2 CASTORS WITH BRAKES RUEDA/ 2 RUEDA CON FRENO	4
N	 BUCHA RODIZIO CASTER WHELL BUJIDE RUEDA	4
P	 LIMITADOR LIMITING PIN PIN LIMITADOR	6
Q	 PARAFUSO 4X12mm SCREW 4X12mm TORNILLO 4X12mm	8
R	 CALÇO PARA DOBRADIÇA HINGE SHED CALZO DE BISAGRA	2
S	 DOBRADIÇA HINGE BIZAGRA	2
T	 PUXADOR PULLER TIRADOR	1
V	 COLA GLUE PEGAMENTO	1
Y	 TAPA-FURO HOLE COVER TAPA AGUJERO	12

UTILIZE A RÉGUA PARA IDENTIFICAR OS PARAFUSOS  
USE THE RULER TO IDENTIFY THE SCREWS  
UTILICE LA REGLA PARA IDENTIFICAR LOS TORNILLOS

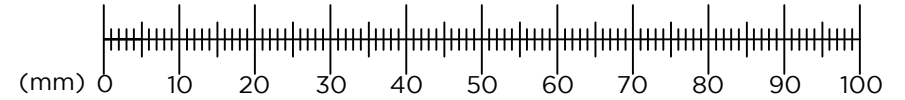

**PESO SUPORTADO / WEIGHT SUPPORTED / PESO SOPORTADO**

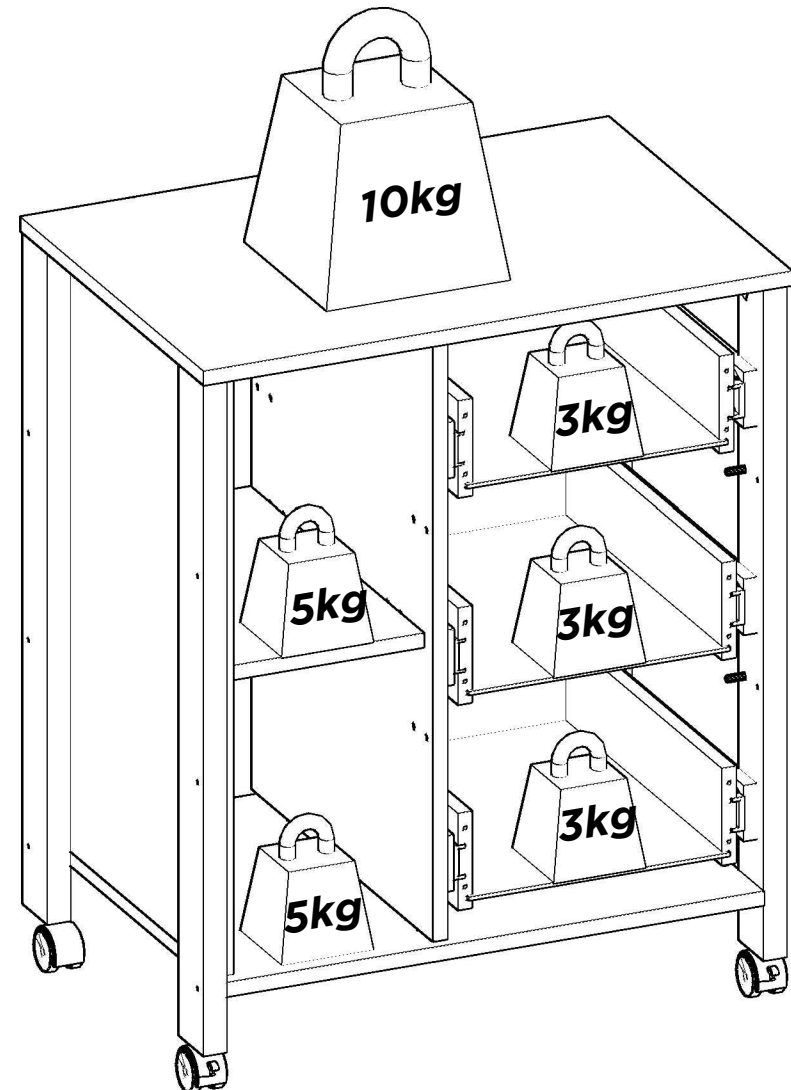

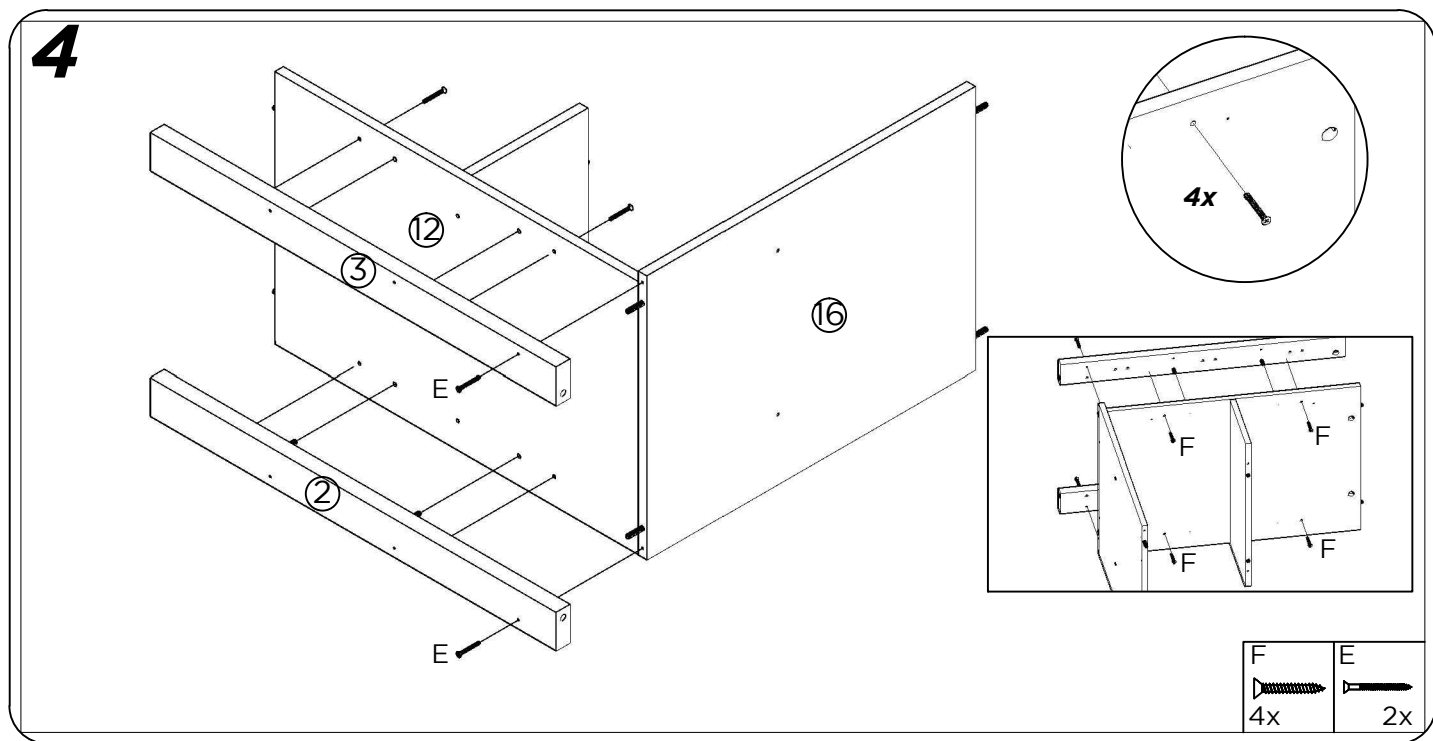
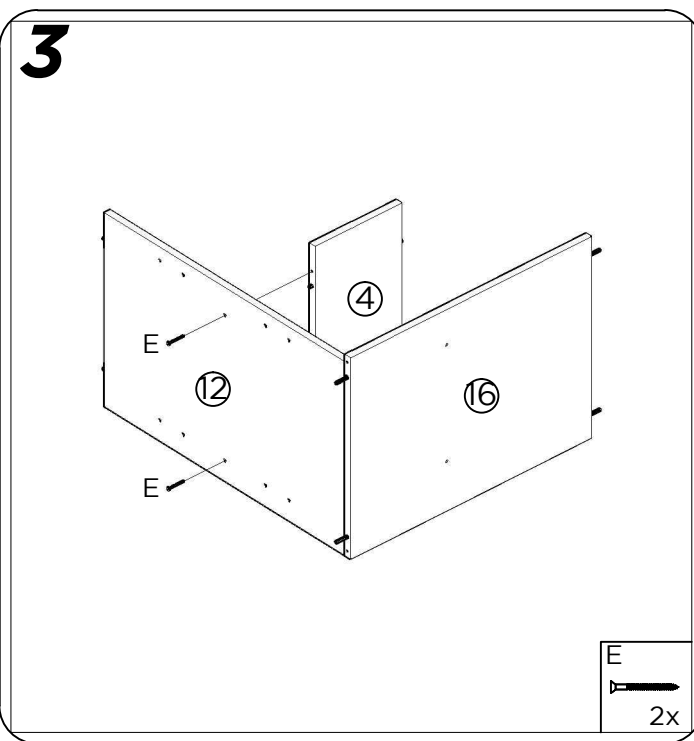
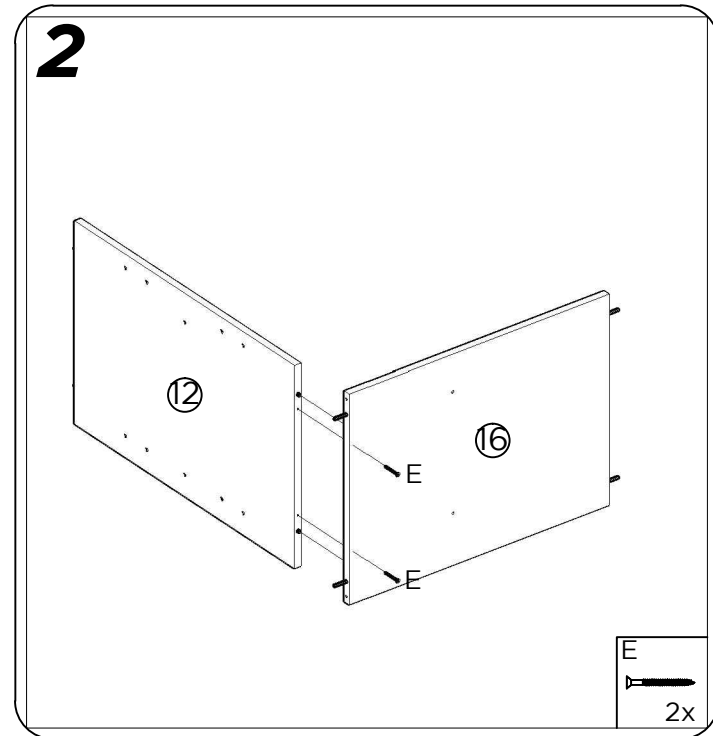
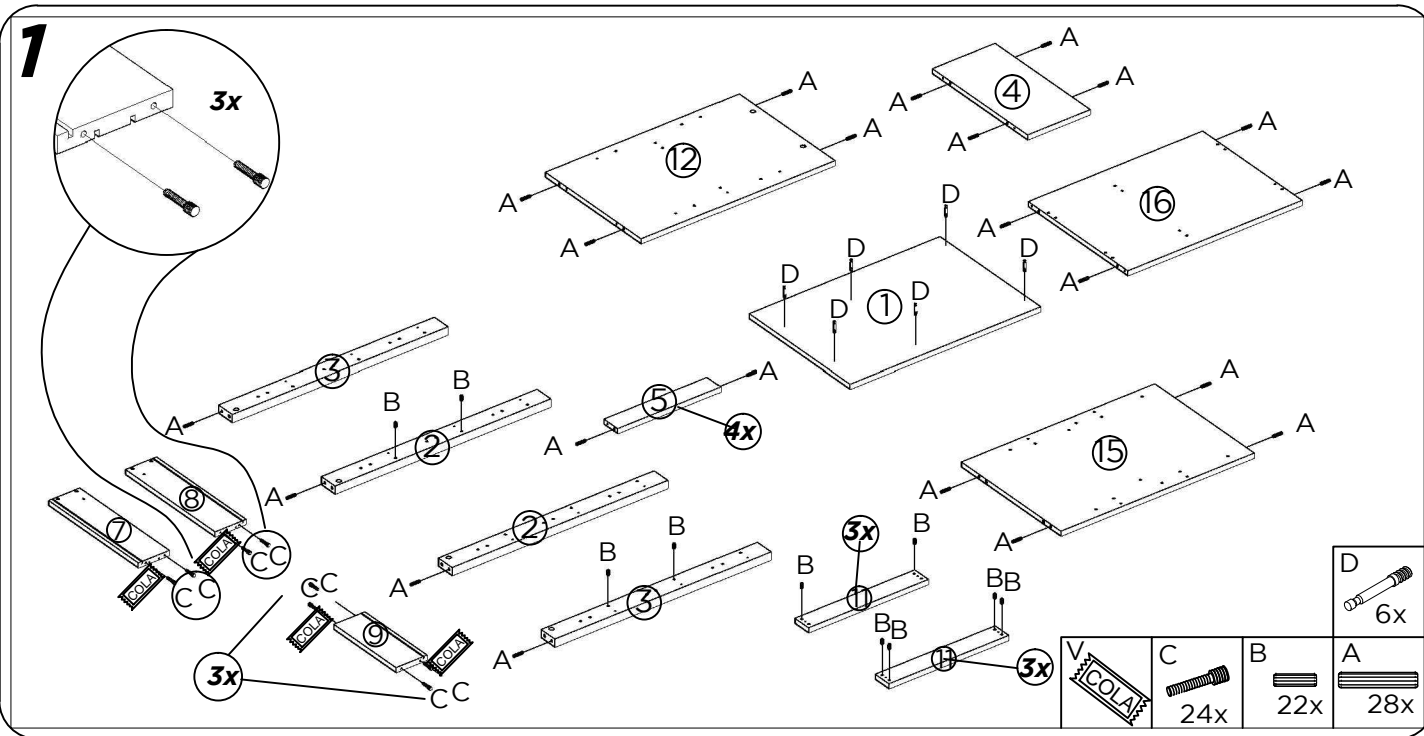



10

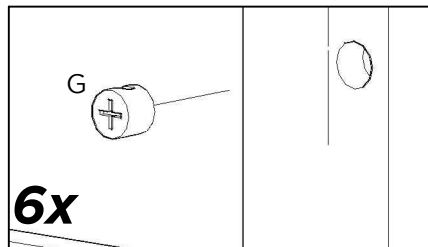
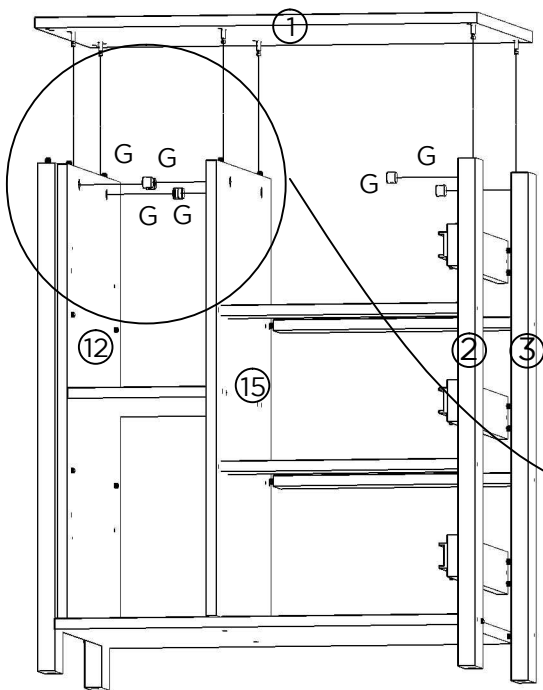

6x

G  
6x



11

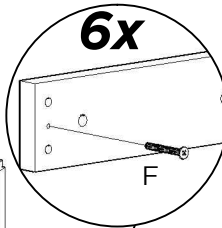
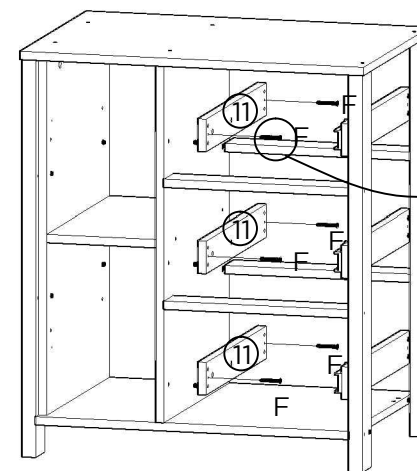

6x

F  
6x



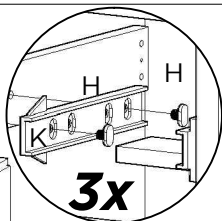
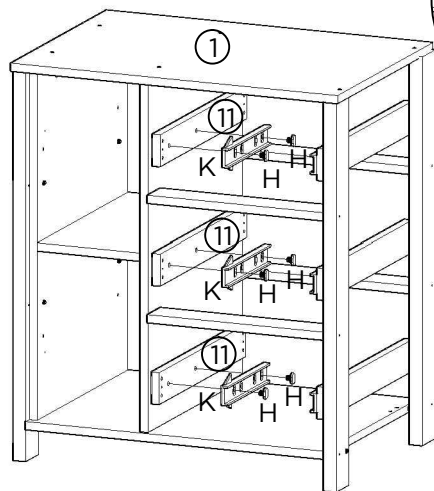

12



3x

K H  
3x 6x

13

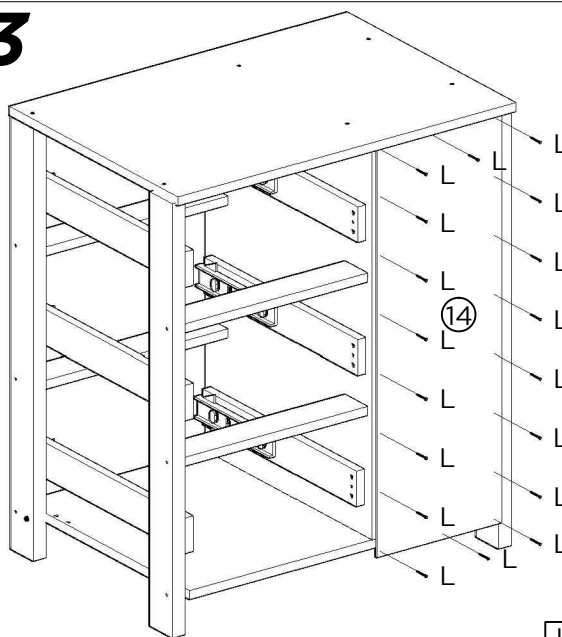

L  
18x



14

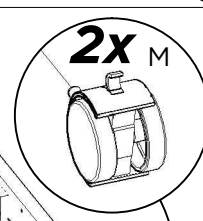
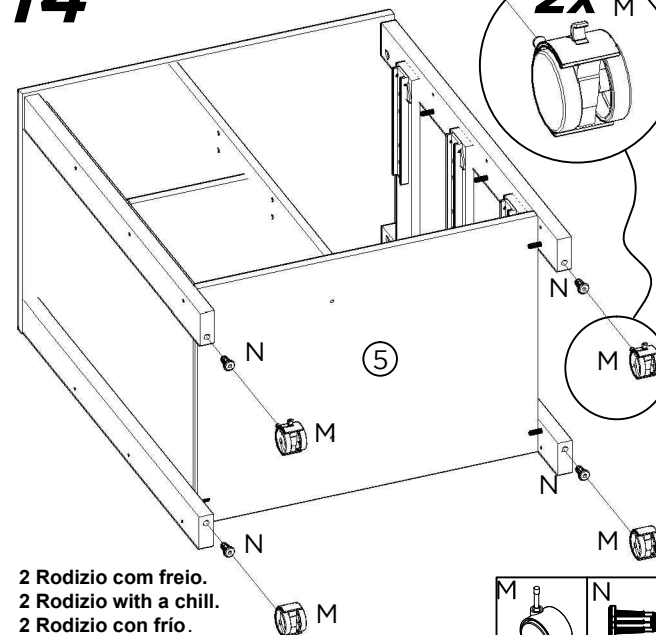

2x M

2 Rodizio com freio.  
2 Rodizio with a chill.  
2 Rodizio con frío.

M N  
4x 4x



# 15

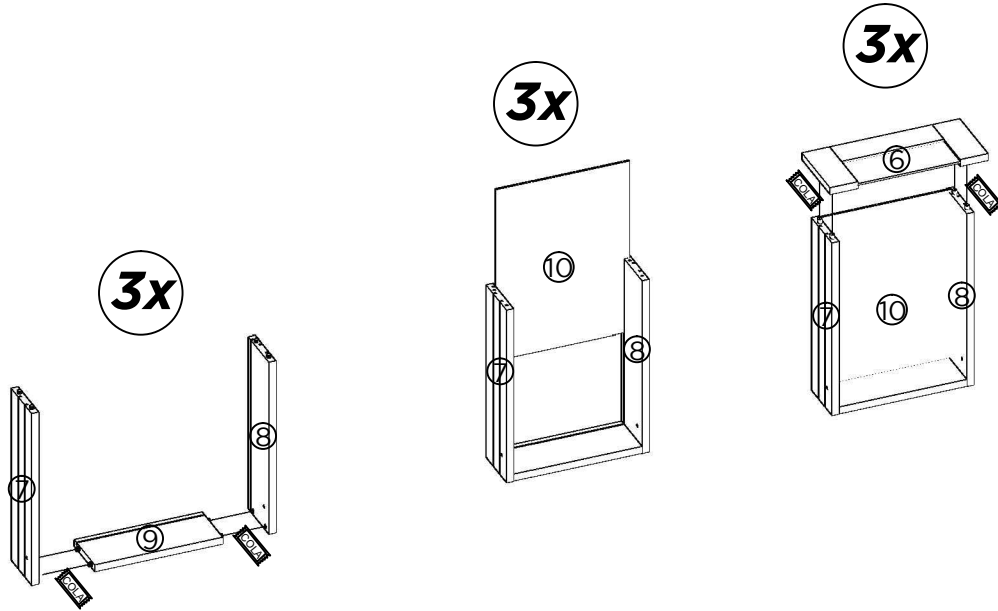

# 16

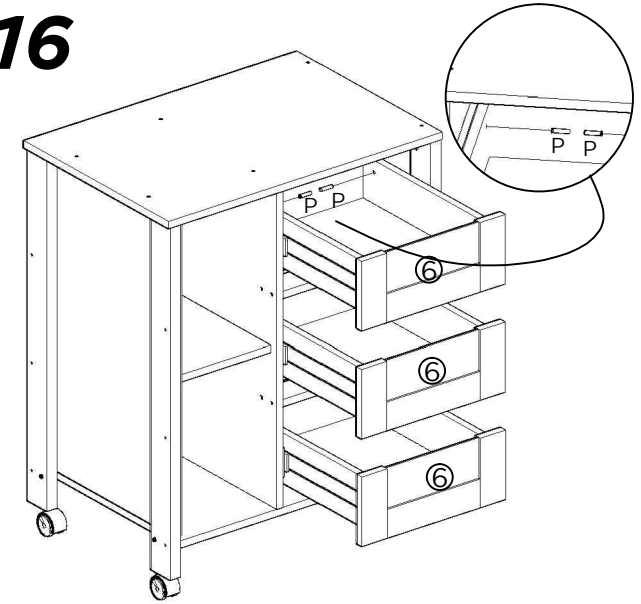

Insira as gaveta e instale o pino limitador.  
 Insert the drawer and install the stop pin.  
 Introduzca el cajón e instale el pasador de tope.



# 17

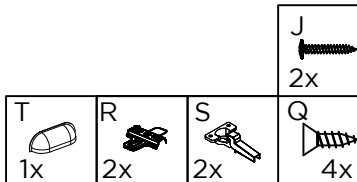
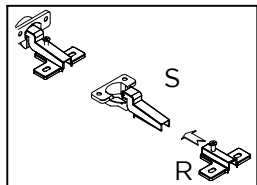
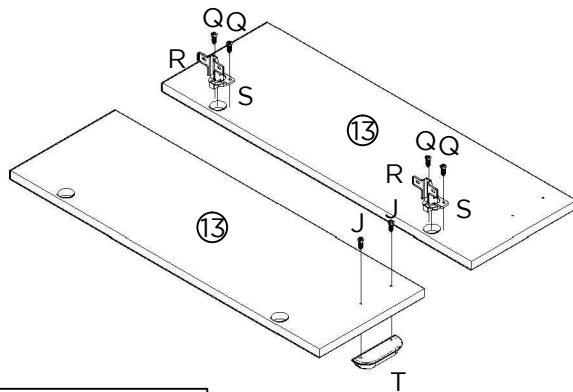

# 18

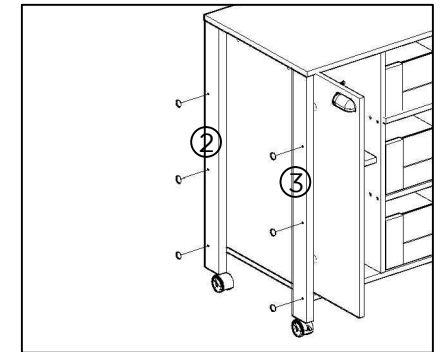
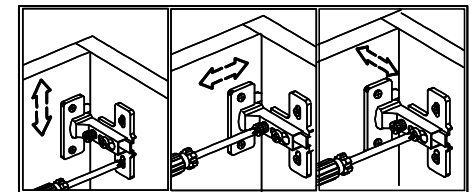
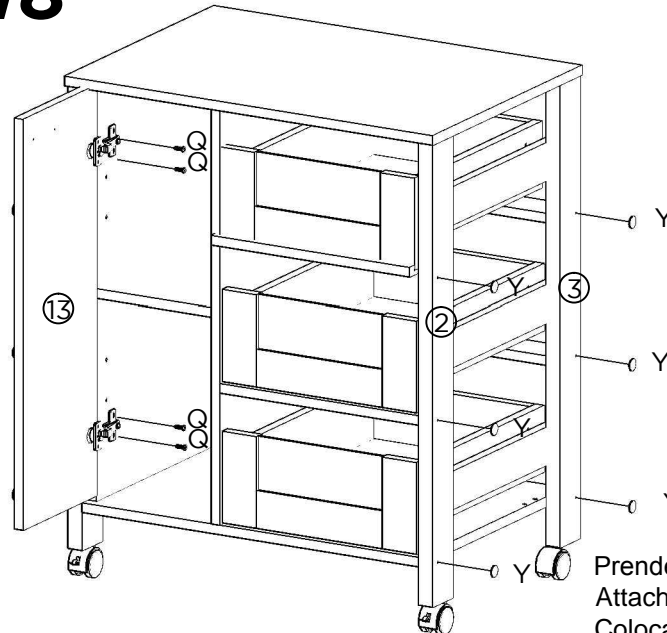

Prender as dobradiçar e acoplar tapa-furos.  
 Attach the hinges and plug the holes.  
 Coloca las bisagras y tapa los agujeros.

