

# ASSEMBLY INSTRUCTIONS

Ref.: 200658 - ELB0061.01

Review 01

INSTRUCTIONS DE MONTAGE | MANUAL DE ARMADO | ESQUEMA DE MONTAGEM

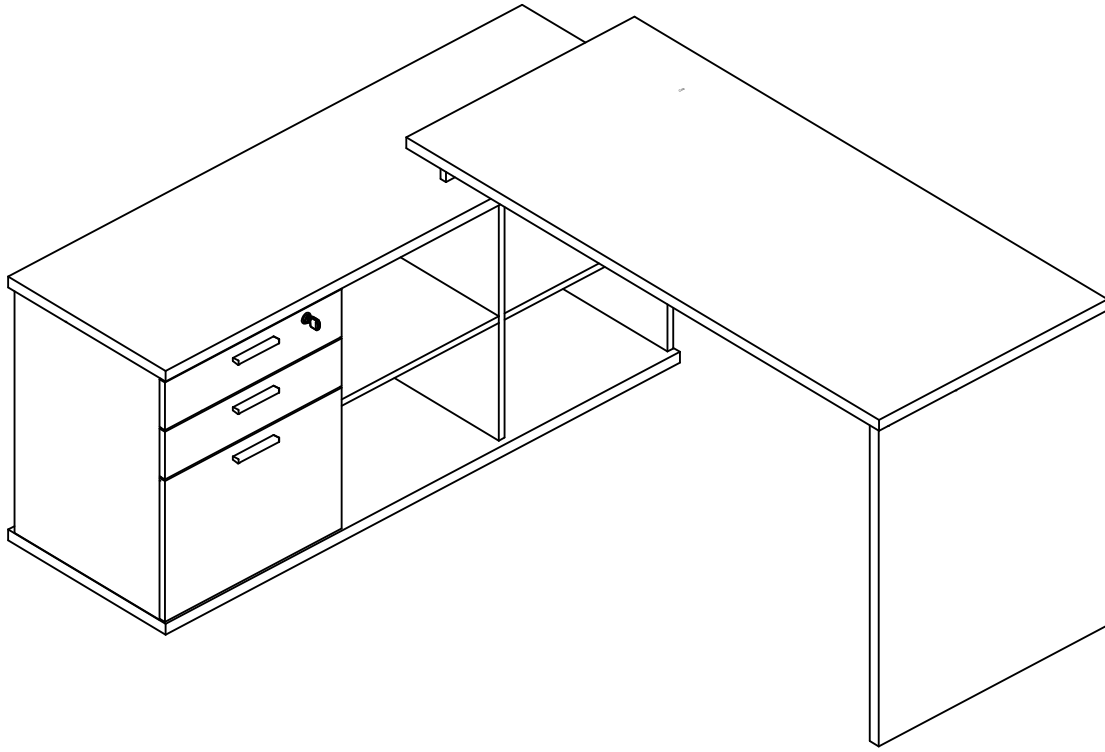

## YOU WILL NEED

TU AURAS BESOIN DE | NECESITARÁ | VOCÊ VAI PRECISAR

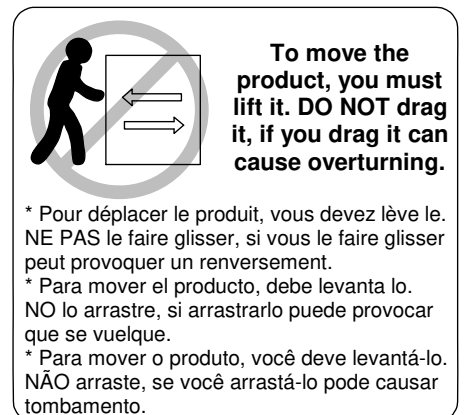
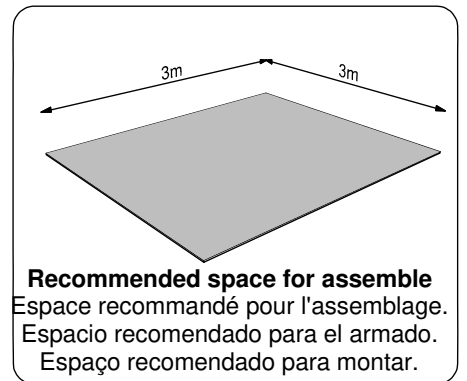
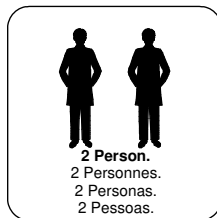
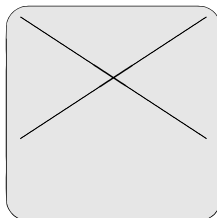
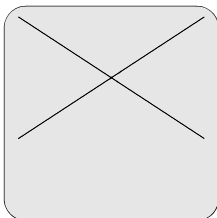
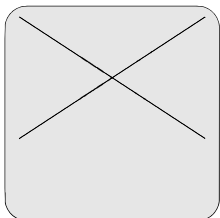
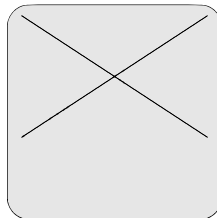
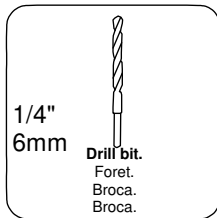
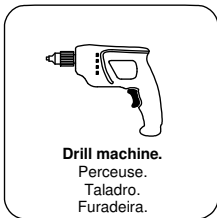
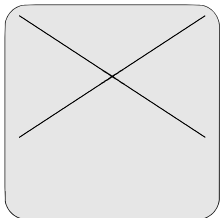
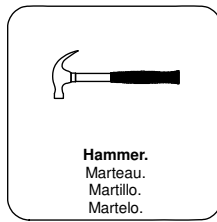
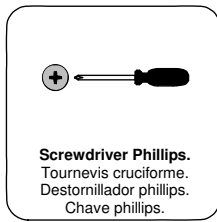
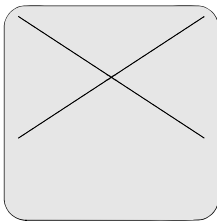
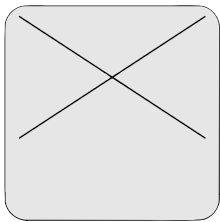

## Tools not included

Outils non inclus | Herramientas no incluidas | Ferramentas não inclusas

# PARTS IDENTIFICATION

IDENTIFICATION DES PIÈCES | IDENTIFICACIÓN DE PIEZAS | IDENTIFICAÇÃO DAS PEÇAS

<b>01</b>	Top Plan de Travail Tapa Tampo	Qty./Qtd. <b>01</b>
<b>02</b>	Side Côté Lateral Lateral	Qty./Qtd. <b>01</b>
<b>03</b>	Top Base Base Supérieure Base Superior Base Superior	Qty./Qtd. <b>01</b>
<b>04</b>	Bottom Base Base Inférieure Base Inferior Base Inferior	Qty./Qtd. <b>01</b>
<b>05</b>	Panel Panneau Panel Painel	Qty./Qtd. <b>01</b>
<b>06</b>	Top holder Support supérieur Titular superior Suporte Tampo	Qty./Qtd. <b>01</b>
<b>07</b>	Left Side Côté Gauche Lateral Izquierdo Lateral Esquerda	Qty./Qtd. <b>01</b>
<b>08</b>	Left Division Division Gauche División Izquierda Divisória Esquerda	Qty./Qtd. <b>01</b>
<b>09</b>	Right Division Division Droite División Derecha Divisória Direita	Qty./Qtd. <b>01</b>
<b>10</b>	Right Side Côté Droite Lateral Derecho Lateral Direita	Qty./Qtd. <b>01</b>
<b>11</b>	Vertical Panel Panneau Vertical Panel Vertical Painel Vertical	Qty./Qtd. <b>01</b>
<b>12</b>	Shelf Étagère Repisa Prateleira	Qty./Qtd. <b>02</b>

<b>13</b>	Bigger Drawer Front Plus Grand Tiroir Avant Frente Mayor Del Cajón Frente de Gaveta Maior	Qty./Qtd. <b>01</b>
<b>14</b>	Smaller Drawer Front Plus Petit Tiroir Avant Frente Menor del Cajón Frente de Gaveta Menor	Qty./Qtd. <b>01</b>
<b>15</b>	Drawer Front Avant de Tiroir Frente del Cajón Frente de Gaveta	Qty./Qtd. <b>01</b>
<b>16</b>	Bigger Rear of Drawer Plus Grand Arrière du Tiroir Posterior de Cajón Mayor Traseiro de Gaveta Maior	Qty./Qtd. <b>01</b>
<b>17</b>	Smaller Rear of Drawer Plus Petit Arrière du Tiroir Posterior de Cajón Menor Traseiro de Gaveta Menor	Qty./Qtd. <b>02</b>
<b>18</b>	Left Side of Drawer Côté Gauche du Tiroir Lateral Izquierdo de Cajón Lateral Esquerda de Gaveta	Qty./Qtd. <b>02</b>
<b>19</b>	Bigger Left Side of Drawer Plus Grand Côté Gauche du Tiroir Lateral Izquierdo Mayor de Cajón Lateral de Gaveta Esquerda Maior	Qty./Qtd. <b>01</b>
<b>20</b>	Right Side of Drawer Côté Droite du Tiroir Lateral Derecho de Cajón Lateral Direita de Gaveta	Qty./Qtd. <b>02</b>
<b>21</b>	Bigger Right Side of Drawer Plus Grand Côté Droite du Tiroir Lateral Derecho Mayor de Cajón Lateral de Gaveta Direita Maior	Qty./Qtd. <b>01</b>
<b>22</b>	Backboard of drawer Arrière du Tiroir Fondo de cajón Fundo de Gaveta	Qty./Qtd. <b>03</b>

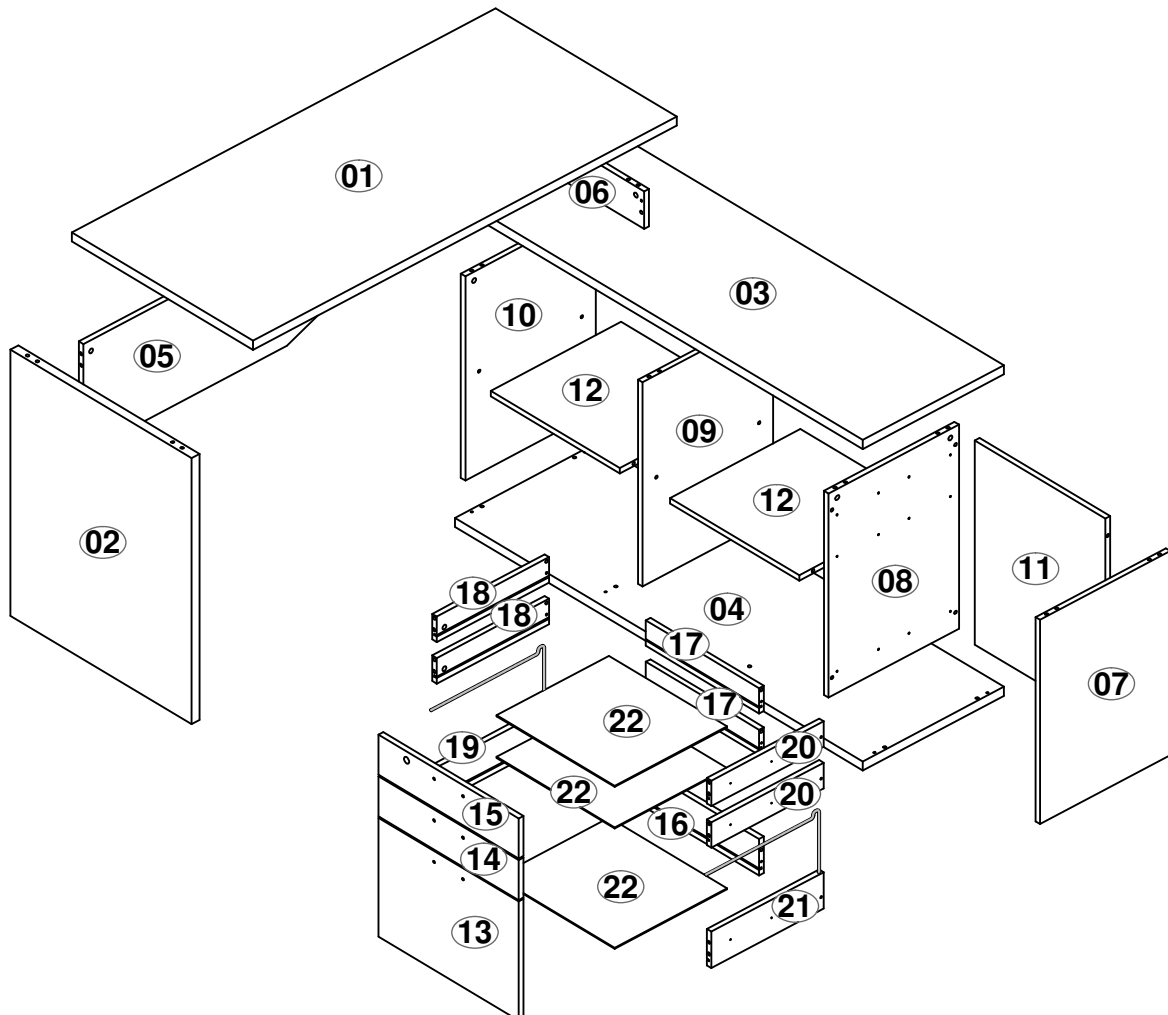

GENERAL DIMENSIONS | DIMENSIONS GÉNÉRALES | DIMENSIONES GENERALES | DIMENSÕES

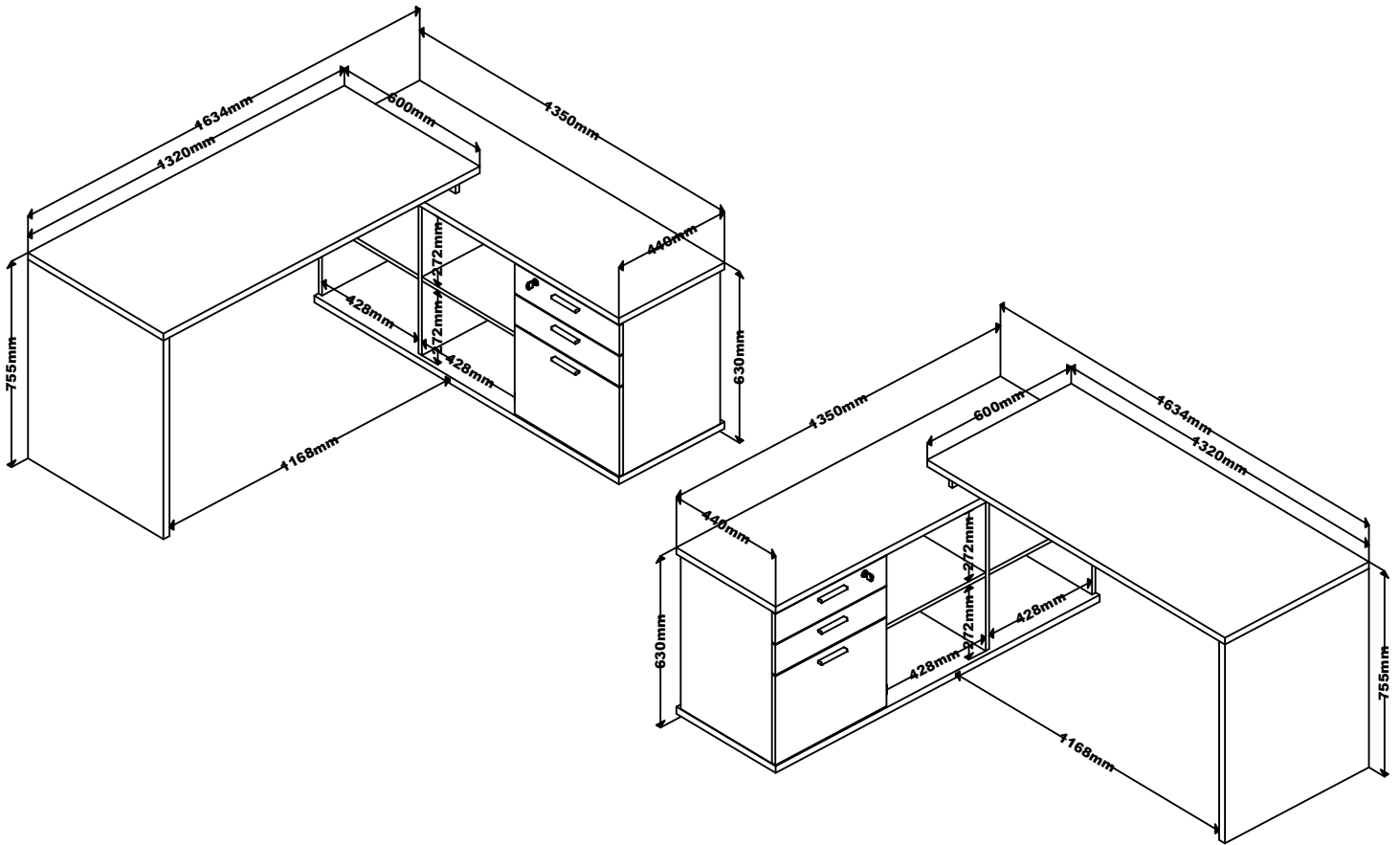

**MAXIMUM RECOMMENDED WEIGHT BEING THIS EVENLY DISTRIBUTED.**  
 LE POIDS MAXIMAL RECOMMANDÉ EST RÉGULIÈREMENT DISTRIBUÉ.  
 PESO MÁXIMO RECOMENDADO SIENDO ESTO UNIFORME REPARTIDO.  
 PESO MÁXIMO RECOMENDADO SENDO ESTE DISTRIBUIDO.

	LB	KG
<b>A</b>	66	30
<b>B</b>	22	10

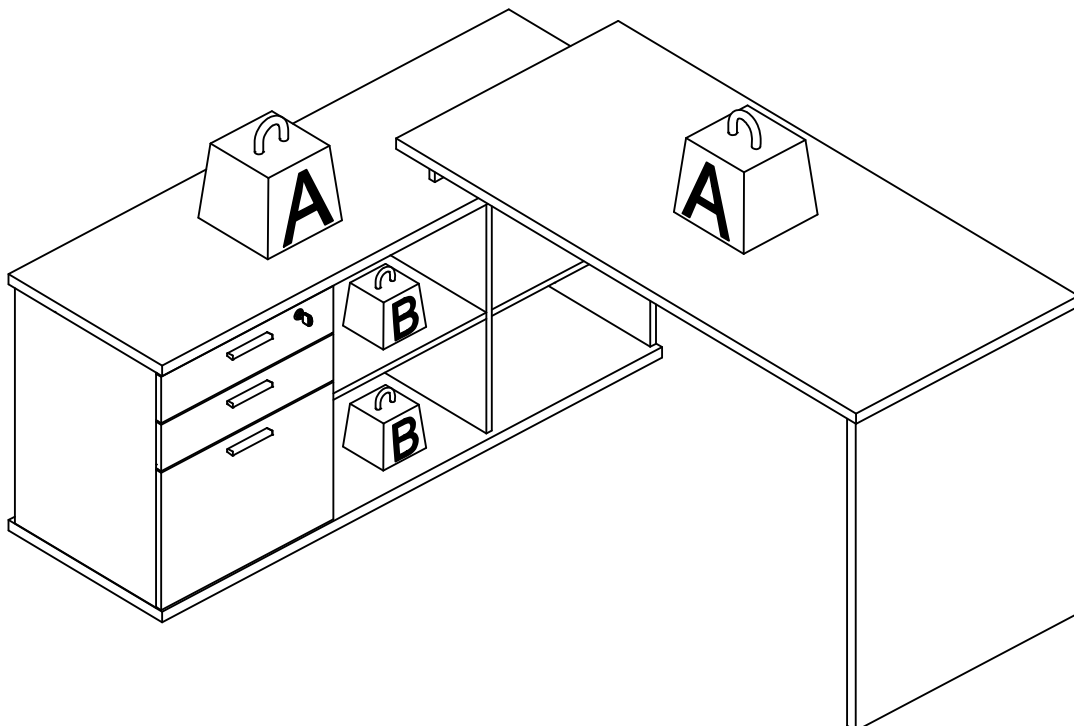

# ACCESSORIES IDENTIFICATION

IDENTIFICATION DES ACCESSOIRES | IDENTIFICACIÓN DE ACCESORIOS | IDENTIFICAÇÃO DOS ACESSÓRIOS

**A**  Qty./Qtd. **43**  
Wooden dowel / Chevilles en bois / Taquete / Caviha

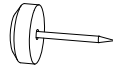
**V**  Qty./Qtd. **2**  
Small plastic foot / Chaussure de glisse / Pie plástico / Sapata Plástica

**AD**  Qty./Qtd. **1**  
Allen key / Clé Allen / Liave allen / Chave Allen

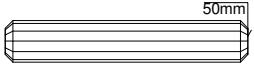
**AM**  Qty./Qtd. **2**  
Wooden dowel / Chevilles en bois / Taquete / Caviha

**B**  Qty./Qtd. **16**  
Structural screw / Vis à tête structurelle / Tornillo estructural / Parafuso Estrutural

**BC**  Qty./Qtd. **6**  
Plastic foot / Pied en Plastique / Pie plástico / Sapata Plástica

**BH**  Qty./Qtd. **1**  
Lock / Serrure / Cerrar / Fechadura

**BK**  Qty./Qtd. **1**  
Door stop / Heurtoir / Tope de puerta / Batente

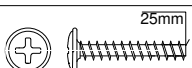
**D**  Qty./Qtd. **6**  
Flanged head screw / Vis à tête bride / Tornillo de cabeza flangeada / Parafuso Flangeado

**F**  Qty./Qtd. **16**  
Structural screw cover/Cache-vis structurel/Tapa tornillo estructural/ Tampa estrutural

**G**  Qty./Qtd. **21**  
Simple minifix screw / Vis minifix simple / Tornillo minifix simple / Haste Minifix Simples

**H**  Qty./Qtd. **21**  
Drum lock / Verrouillage du tambour / Tambor minifix / Tambor de Minifix

**i**  Qty./Qtd. **21**  
Bore patch adhesive / Adhésif de correction d'alésage / Tapones adhesivo/ Adesivo Tapa Furo

**K**  Qty./Qtd. **1**  
Glue / Colle / Pegamento / Bisnaga de Cola

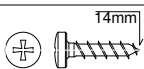
**N**  Qty./Qtd. **28**  
Pan head screw / Vis à tête bombée / Tornillo de pan / Parafuso Panela

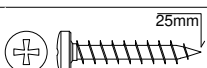
**O**  Qty./Qtd. **6**  
Pan head screw / Vis à tête bombée / Tornillo de pan / Parafuso Panela

**Separating the accessories before starting the assembly will make it easier.**

Séparer les accessoires avant de commencer le montage vous facilitera la tâche.

Separar los accesorios antes de comenzar el montaje lo hará más fácil.

Separar os acessórios antes de iniciar a montagem facilitará.

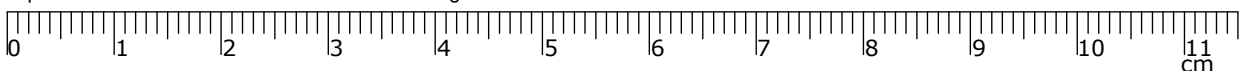

# PRE-ASSEMBLY - PRÉ-ASSEMBLAGE - PRE-ARMADO PRÉ-MONTAGEM

- 01 -** \*Fix accessory ( **G** ) and accessory ( **N** ) to part **03** .  
\*Fixez l'accessoire ( **G** ) et l'accessoire ( **N** ) à la pièce **03** .  
\*Fijar accesorio ( **G** ) y accesorio ( **N** ) a pieza **03** .  
\*Fixe o acessório ( **G** ) e o acessório ( **N** ) na peça **03** .

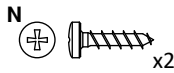
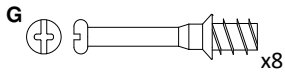
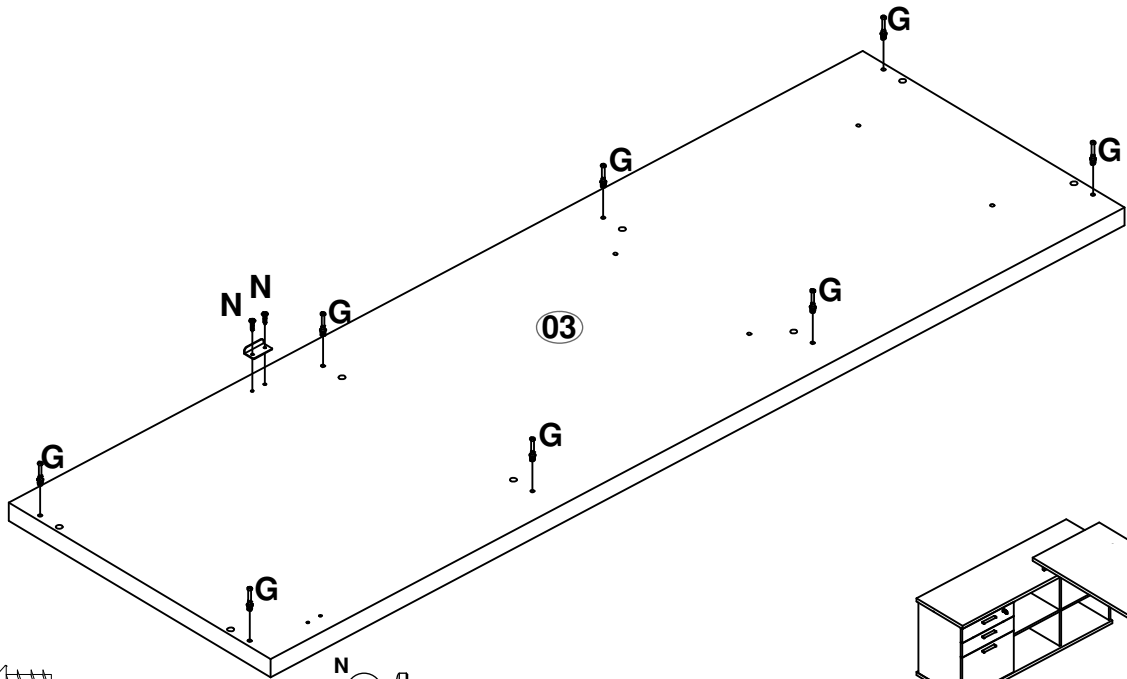
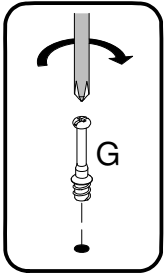

- 02 -** \*Fix accessory ( **G** ) and accessory ( **N** ) to part **03** .  
\*Fixez l'accessoire ( **G** ) et l'accessoire ( **N** ) à la pièce **03** .  
\*Fijar accesorio ( **G** ) y accesorio ( **N** ) a pieza **03** .  
\*Fixe o acessório ( **G** ) e o acessório ( **N** ) na peça **03** .

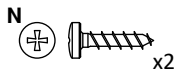
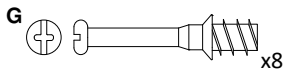
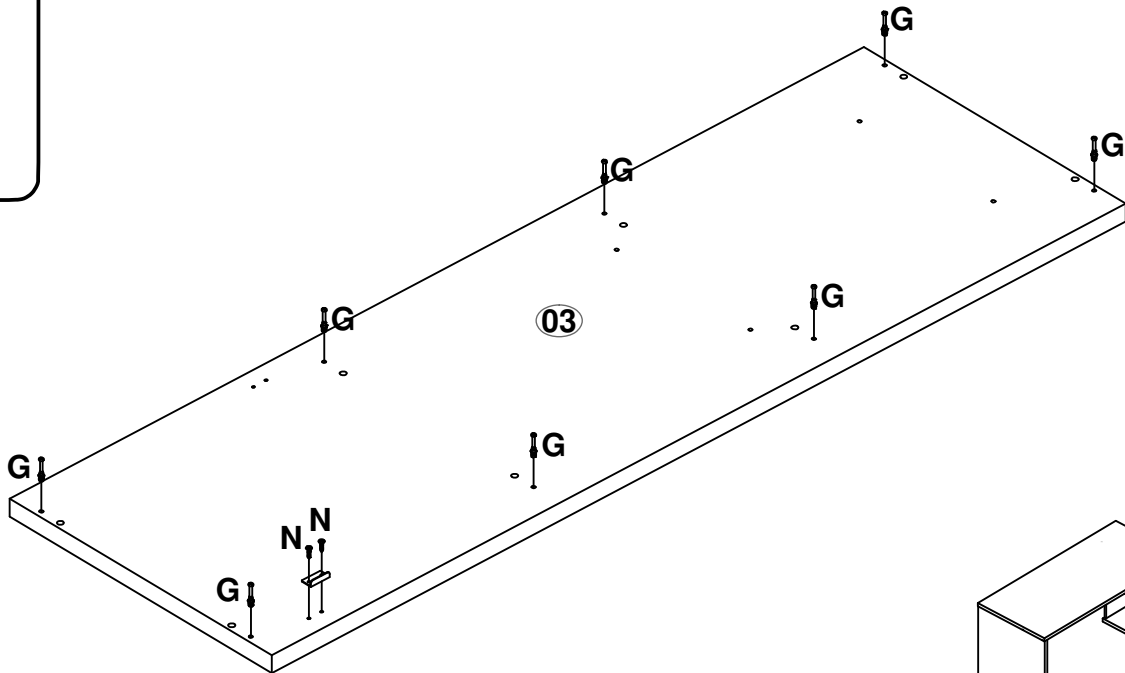
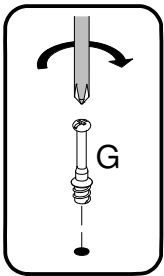

- 03 -** \*Fix accessory ( **A** ) and accessory ( **G** ) to part **02** .  
 \*Fixez l'accessoire ( **A** ) et l'accessoire ( **G** ) à la pièce **02** .  
 \*Fijar accesorio ( **A** ) y accesorio ( **G** ) a pieza **02** .  
 \*Fixe o acessório ( **A** ) e o acessório ( **G** ) na peça **02** .

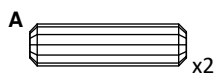
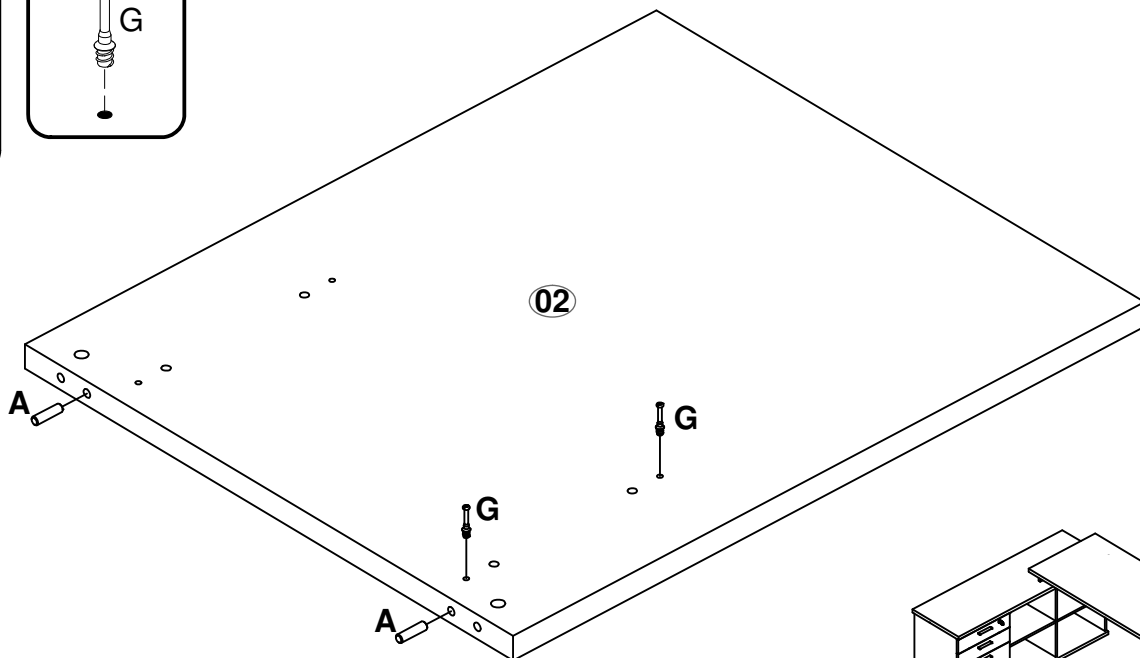
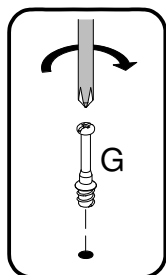
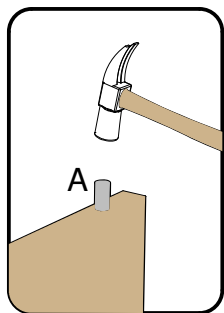

- 04 -** \*Fix accessory ( **A** ) and accessory ( **G** ) to part **02** .  
 \*Fixez l'accessoire ( **A** ) et l'accessoire ( **G** ) à la pièce **02** .  
 \*Fijar accesorio ( **A** ) y accesorio ( **G** ) a pieza **02** .  
 \*Fixe o acessório ( **A** ) e o acessório ( **G** ) na peça **02** .

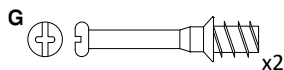
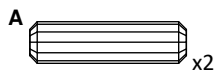
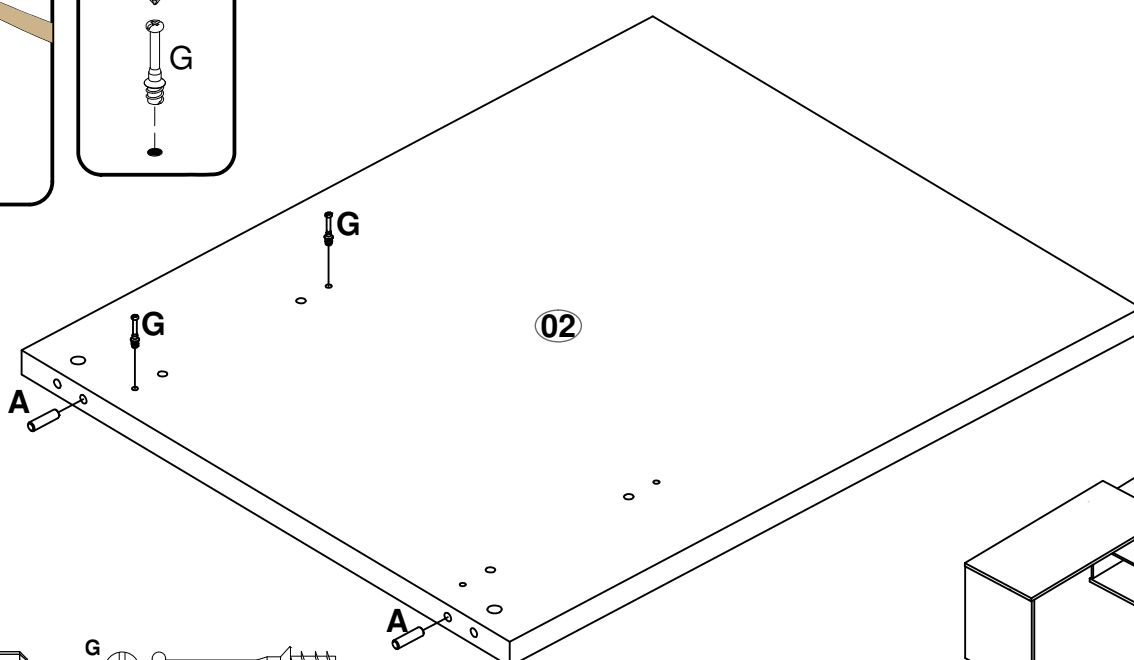
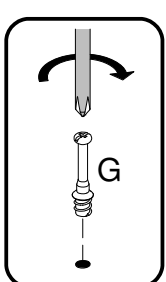
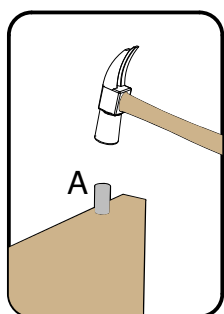

- 05** - \*Fix accessory ( **G** ) and accessory ( **A** ) to part **06** .  
 \*Fixez l'accessoire ( **G** ) et l'accessoire ( **A** ) à la pièce **06** .  
 \*Fijar accesorio ( **G** ) y accesorio ( **A** ) a pieza **06** .  
 \*Fixe o acessório ( **G** ) e o acessório ( **A** ) na peça **06** .

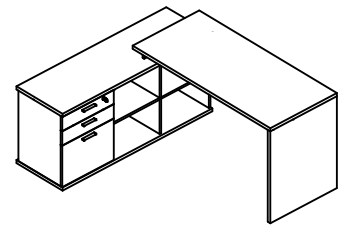
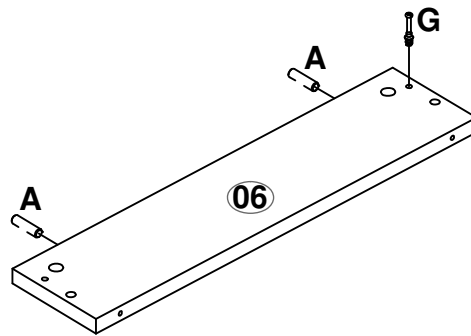
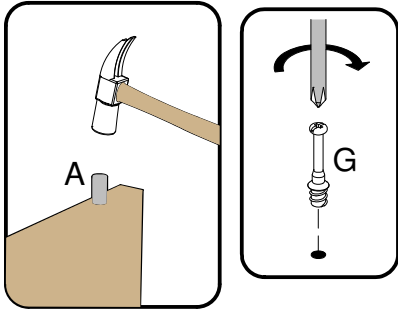

- 06** - \*Fix accessory ( **G** ) and accessory ( **A** ) to part **06** .  
 \*Fixez l'accessoire ( **G** ) et l'accessoire ( **A** ) à la pièce **06** .  
 \*Fijar accesorio ( **G** ) y accesorio ( **A** ) a pieza **06** .  
 \*Fixe o acessório ( **G** ) e o acessório ( **A** ) na peça **06** .

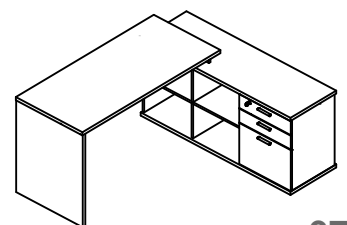
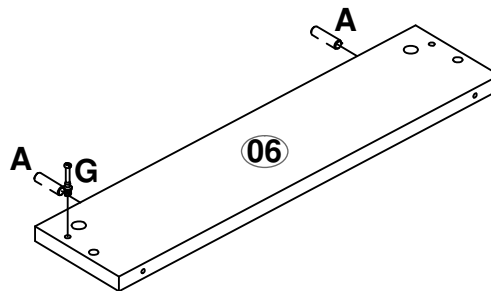
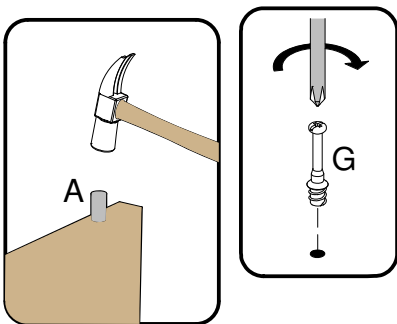

- 07 -** \*Fix accessory ( **A** ) and accessory ( **Y2** ) with accessory ( **N** ) to part **07** .  
 \*Fixez l'accessoire ( **A** ) et l'accessoire ( **Y2** ) avec l'accessoire ( **N** ) à la pièce **07** .  
 \*Fijar accesorio ( **A** ) y accesorio ( **Y2** ) con el accesorio ( **N** ) a pieza **07** .  
 \*Fixe o acessório ( **A** ) e o acessório ( **Y2** ) com o acessório ( **N** ) na peça **07** .

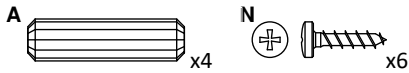
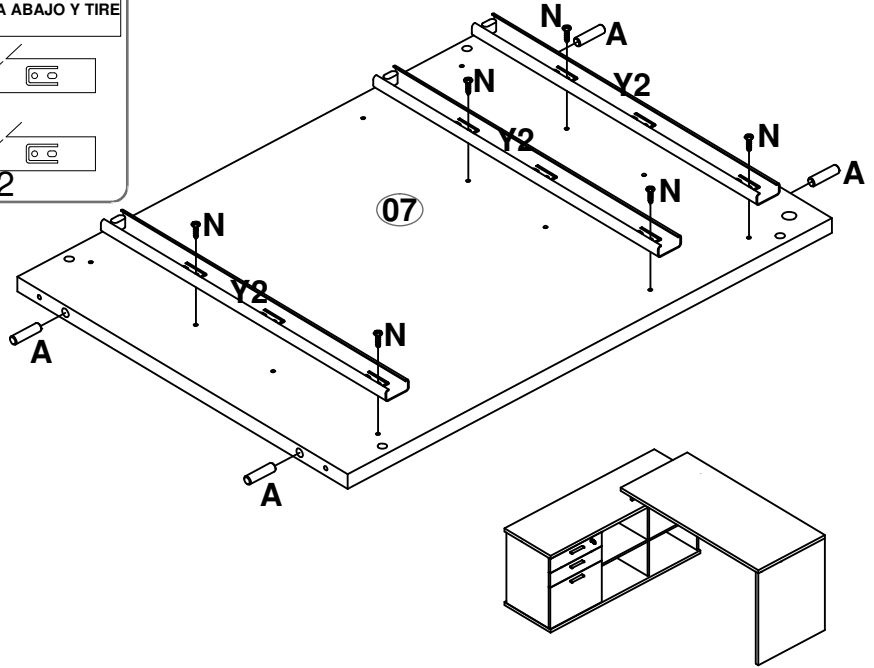
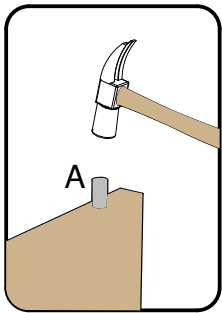
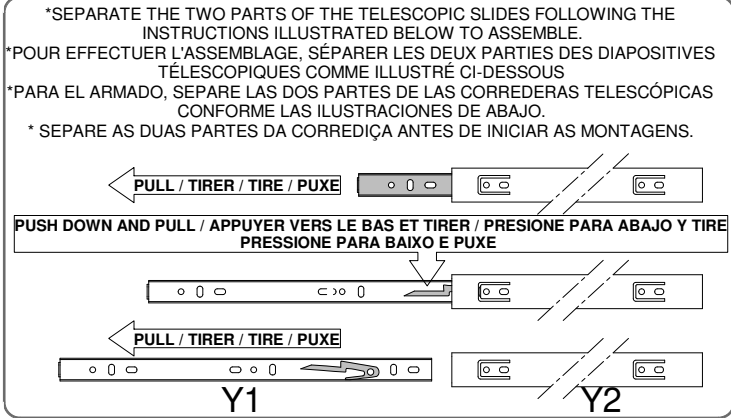

- 08 -** \*Fix accessory ( **A** ) and accessory ( **Y2** ) with accessory ( **N** ) to part **07** .  
 \*Fixez l'accessoire ( **A** ) et l'accessoire ( **Y2** ) avec l'accessoire ( **N** ) à la pièce **07** .  
 \*Fijar accesorio ( **A** ) y accesorio ( **Y2** ) con el accesorio ( **N** ) a pieza **07** .  
 \*Fixe o acessório ( **A** ) e o acessório ( **Y2** ) com o acessório ( **N** ) na peça **07** .

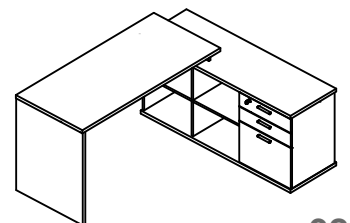
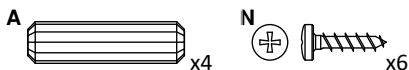
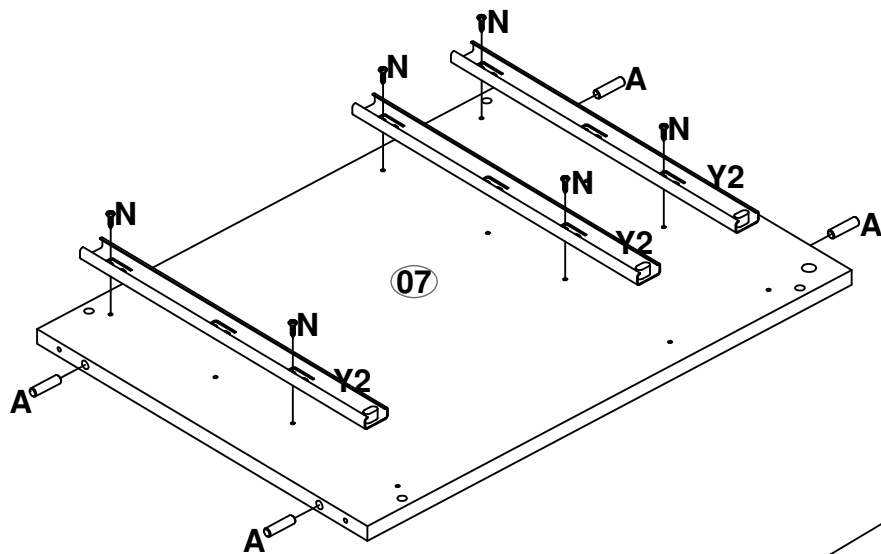
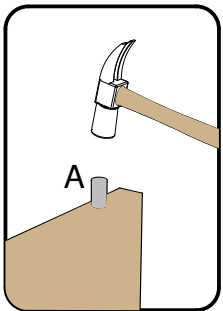

- 09** - \*Fix accessory ( **A** ) and accessory ( **Y2** ) with accessory ( **N** ) to part **08** .  
 \*Fixez l'accessoire ( **A** ) et l'accessoire ( **Y2** ) avec l'accessoire ( **N** ) à la pièce **08** .  
 \*Fijar accesorio ( **A** ) y accesorio ( **Y2** ) con el accesorio ( **N** ) a pieza **08** .  
 \*Fixe o acessório ( **A** ) e o acessório ( **Y2** ) com o acessório ( **N** ) na peça **08** .

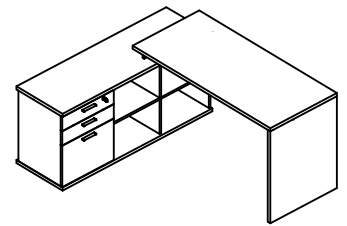
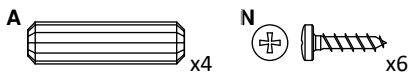
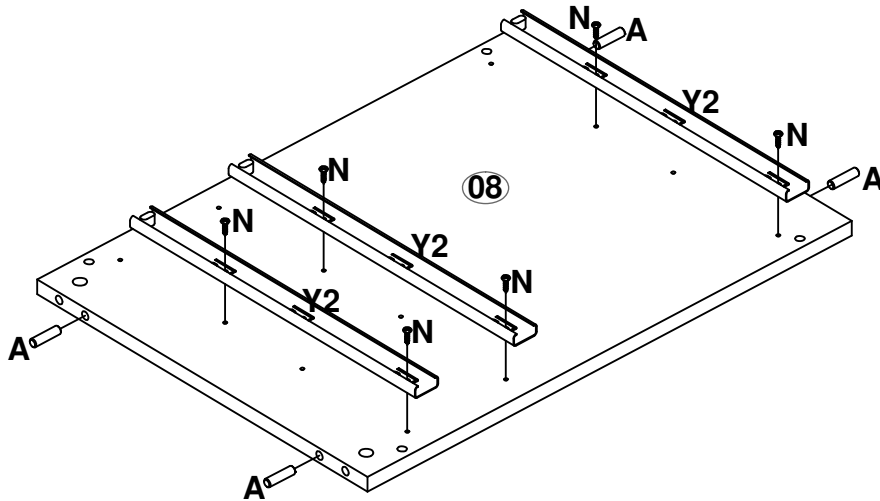
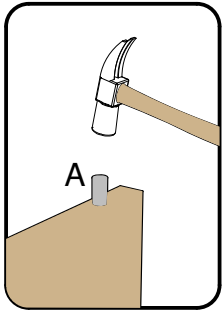

- 10** - \*Fix accessory ( **A** ) and accessory ( **Y2** ) with accessory ( **N** ) to part **08** .  
 \*Fixez l'accessoire ( **A** ) et l'accessoire ( **Y2** ) avec l'accessoire ( **N** ) à la pièce **08** .  
 \*Fijar accesorio ( **A** ) y accesorio ( **Y2** ) con el accesorio ( **N** ) a pieza **08** .  
 \*Fixe o acessório ( **A** ) e o acessório ( **Y2** ) com o acessório ( **N** ) na peça **08** .

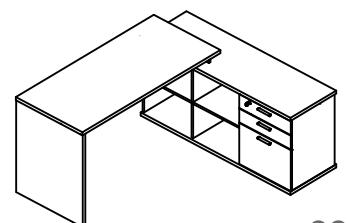
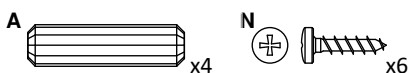
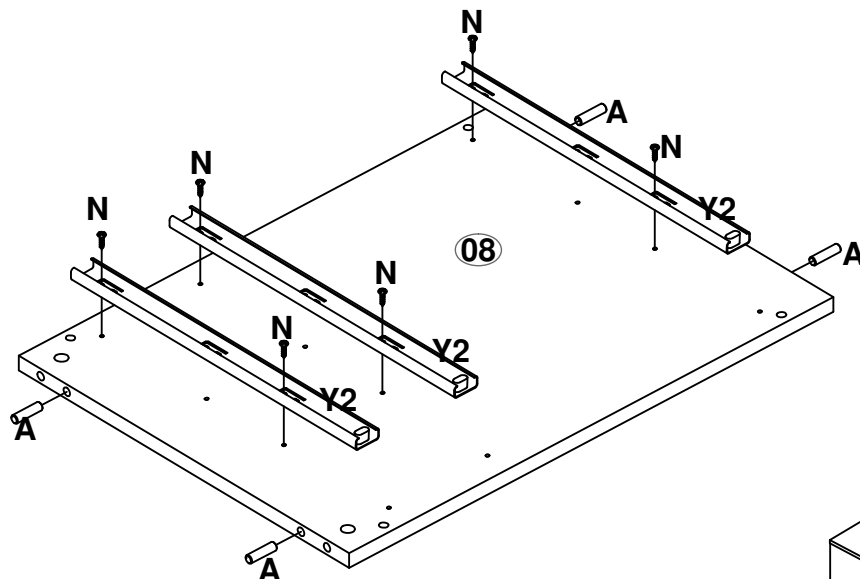
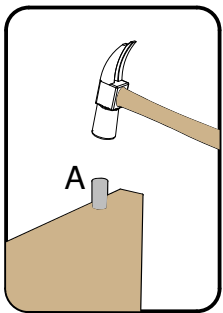

- 11 - \*Fix accessory ( **G** ) to part **01**.  
 \*Fixez l'accessoire ( **G** ) à la pièce **01**.  
 \*Fijar accesorio ( **G** ) a pieza **01**.  
 \*Fixe o acessório ( **G** ) na peça **01**.

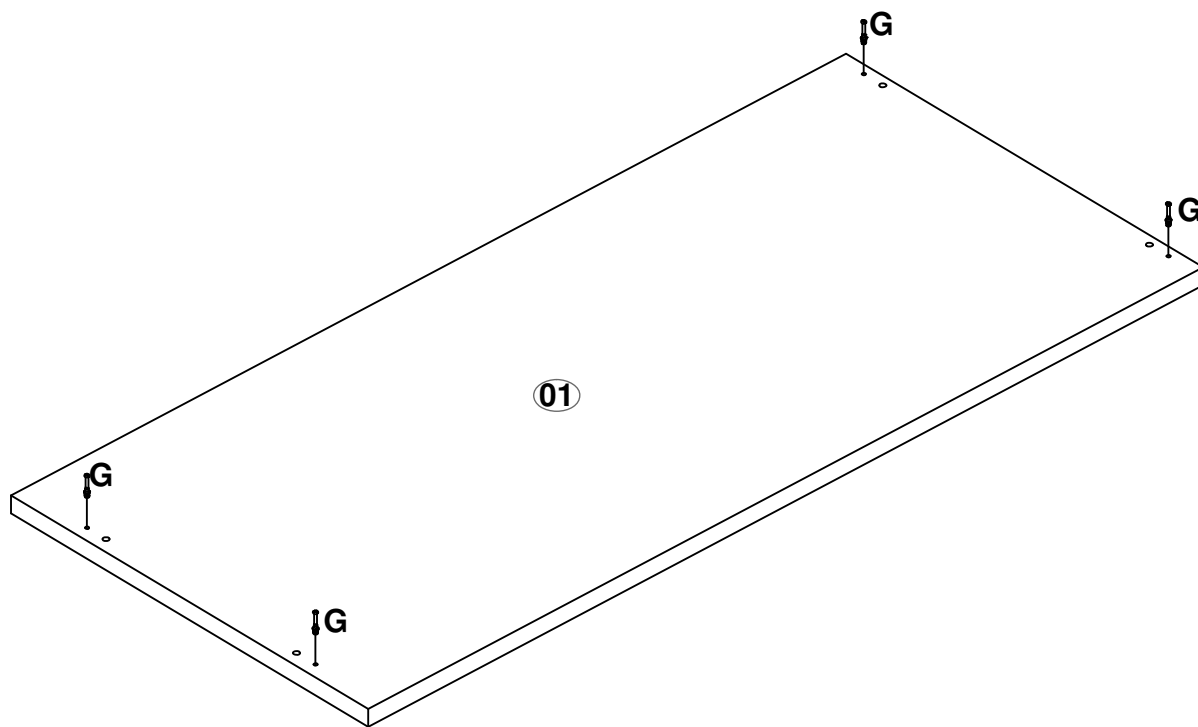
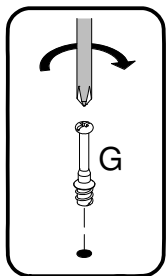

- 12 - \*Fix accessory ( **A** ) to part **05**.  
 \*Fixez l'accessoire ( **A** ) à la pièce **05**.  
 \*Fijar accesorio ( **A** ) a pieza **05**.  
 \*Fixe o acessório ( **A** ) na peça **05**.

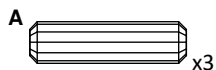
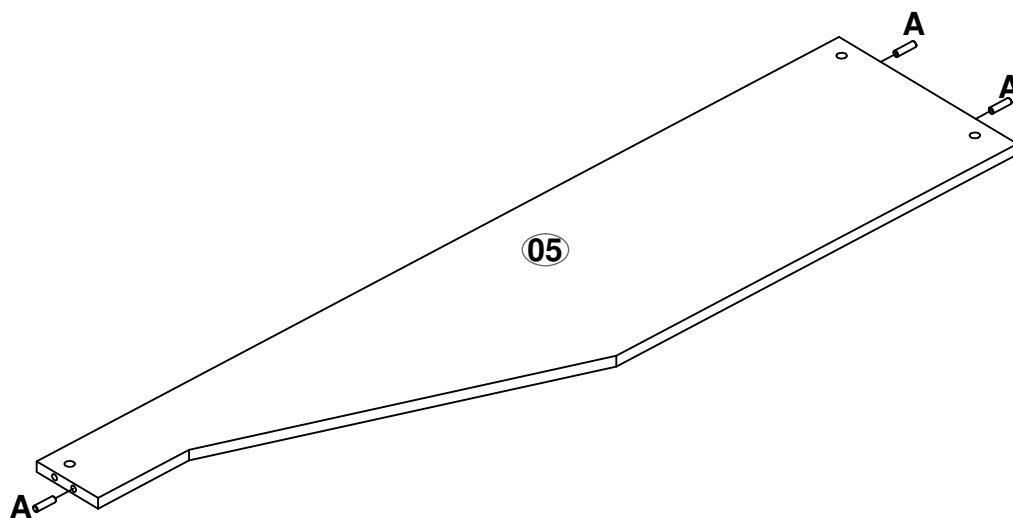
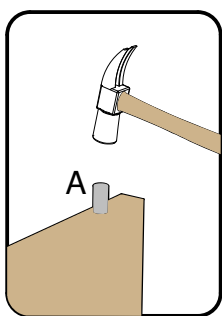

- 13 - \*Fix accessory ( **A** ) to part 11.  
\*Fixez l'accessoire ( **A** ) à la pièce 11.  
\*Fijar accesorio ( **A** ) a pieza 11.  
\*Fixe o acessório ( **A** ) na peça 11.

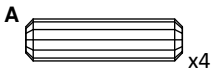
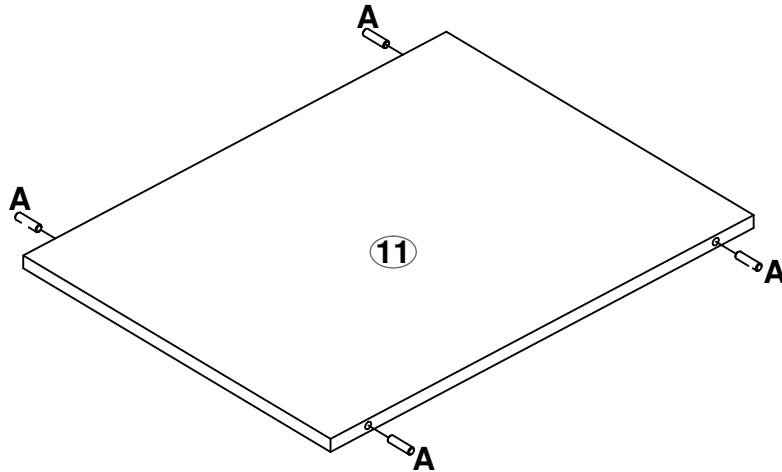
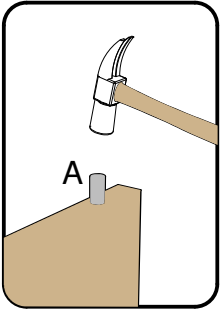

- 14 - \*Fix accessory ( **A** ) to part 09.  
\*Fixez l'accessoire ( **A** ) à la pièce 09.  
\*Fijar accesorio ( **A** ) a pieza 09.  
\*Fixe o acessório ( **A** ) na peça 09.

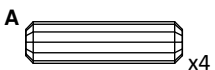
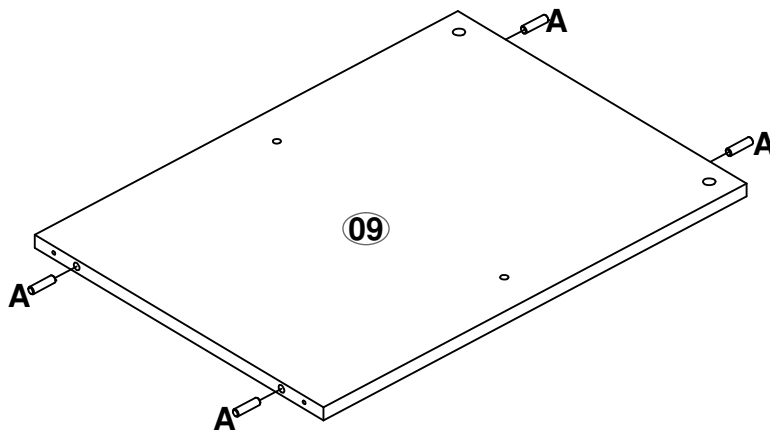
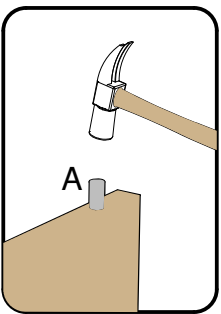

- 15 - \*Fix accessory ( **A** ) to part **10** .  
 \*Fixez l'accessoire ( **A** ) à la pièce **10** .  
 \*Fijar accesorio ( **A** ) a pieza **10** .  
 \*Fixe o acessório ( **A** ) na peça **10** .

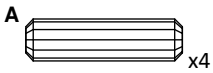
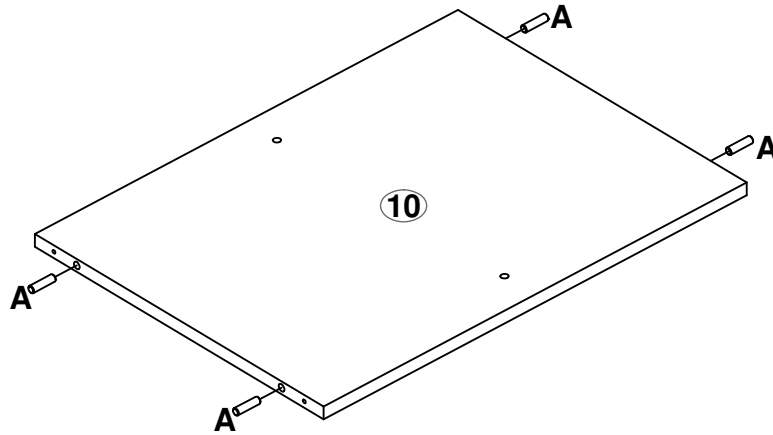
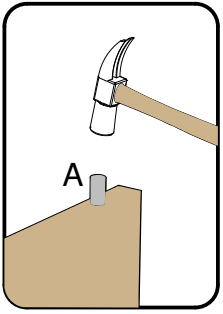

- 16 - \*Fix accessory ( **G** ) and accessory ( **D** ) to part **13** .  
 \*Fixez l'accessoire ( **G** ) et l'accessoire ( **D** ) à la pièce **13** .  
 \*Fijar accesorio ( **G** ) y accesorio ( **D** ) a pieza **13** .  
 \*Fixe o acessório ( **G** ) e o acessório ( **D** ) na peça **13** .

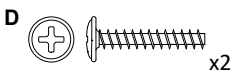
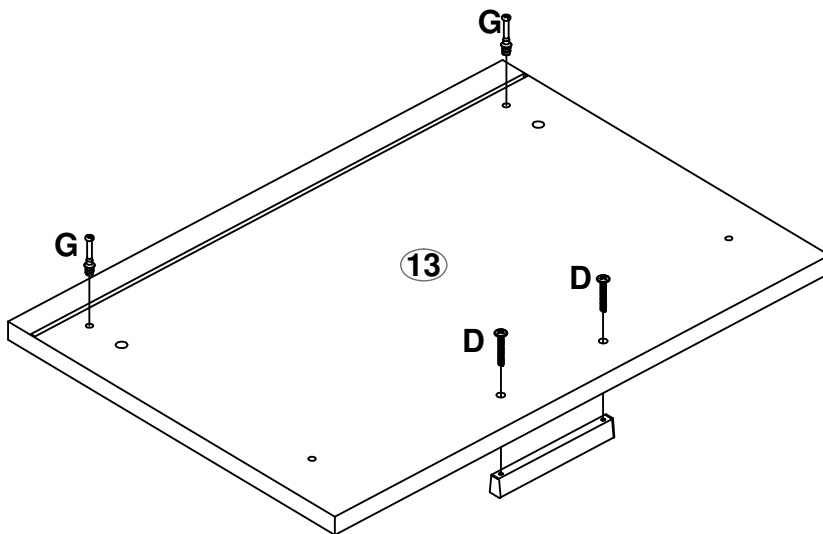
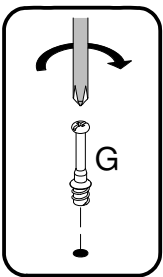

- 17 - \*Fix accessory ( **G** ) and accessory ( **D** ) to part **(14)**.  
 \*Fixez l'accessoire ( **G** ) et l'accessoire ( **D** ) à la pièce **(14)**.  
 \*Fijar accesorio ( **G** ) y accesorio ( **D** ) a pieza **(14)**.  
 \*Fixe o acessório ( **G** ) e o acessório ( **D** ) na peça **(14)**.

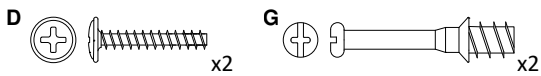
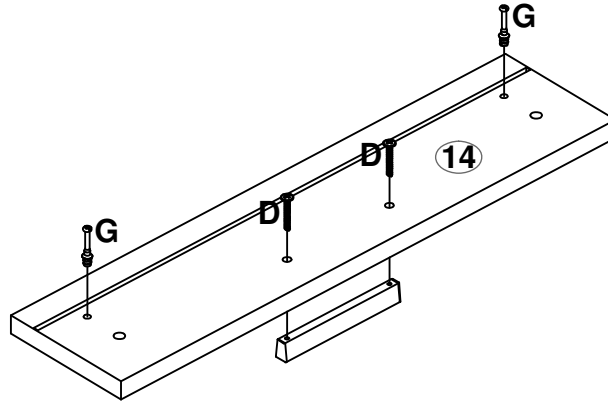
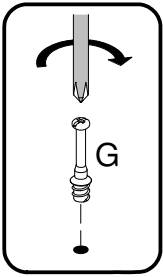

- 18 - \*Fix accessory ( **G** ) and accessory ( **D** ) to part **(15)**.  
 \*Fixez l'accessoire ( **G** ) et l'accessoire ( **D** ) à la pièce **(15)**.  
 \*Fijar accesorio ( **G** ) y accesorio ( **D** ) a pieza **(15)**.  
 \*Fixe o acessório ( **G** ) e o acessório ( **D** ) na peça **(15)**.

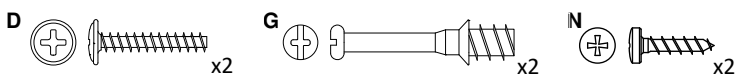
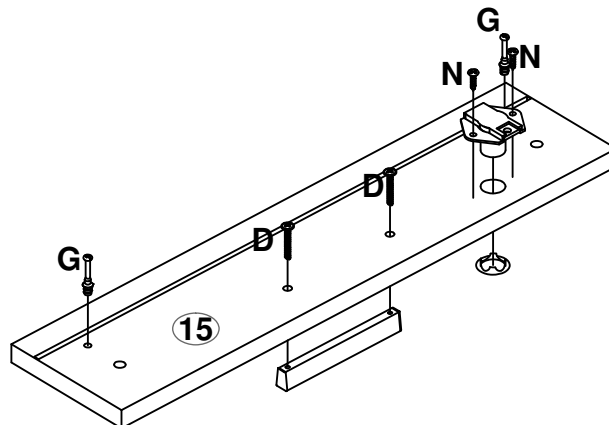
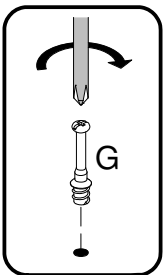

- 19 - \*Fix accessory ( **A** ) and accessory ( **AM** ) to part **12** .  
 \*Fixez l'accessoire ( **A** ) et l'accessoire ( **AM** ) à la pièce **12** .  
 \*Fijar accesorio ( **A** ) y accesorio ( **AM** ) a pieza **12** .  
 \*Fixe o acessório ( **A** ) e o acessório ( **AM** ) na peça **12** .

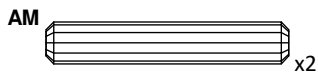
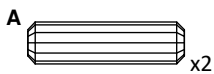
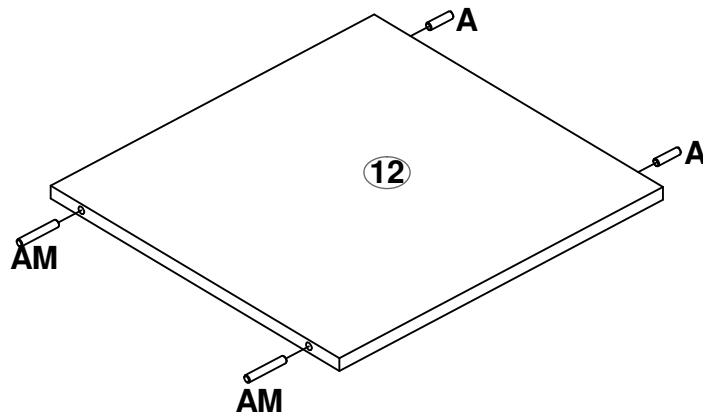
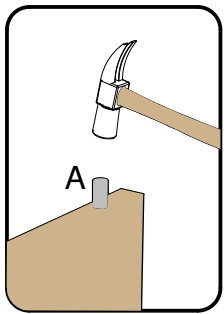

- 20 - \*Fix accessory ( **A** ) to part **16** .  
 \*Fixez l'accessoire ( **A** ) à la pièce **16** .  
 \*Fijar accesorio ( **A** ) a pieza **16** .  
 \*Fixe o acessório ( **A** ) na peça **16** .

- \*Fix accessory ( **A** ) to part **17** .  
 \*Fixez l'accessoire ( **A** ) à la pièce **17** .  
 \*Fijar accesorio ( **A** ) a pieza **17** .  
 \*Fixe o acessório ( **A** ) na peça **17** .

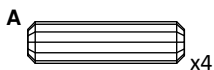
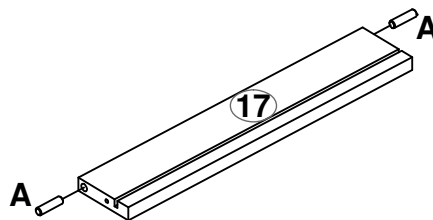
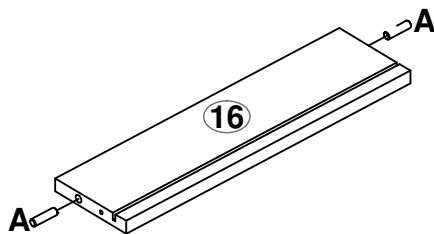
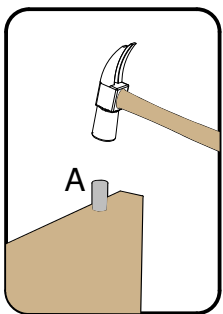

- 21 -** \*Fix accessory ( **A** ) and accessory ( **Y1** ) with accessory ( **N** ) to part **(20) (18)**  
 \*Fixez l'accessoire ( **A** ) et l'accessoire ( **Y1** ) avec l'accessoire ( **N** ) à la pièce **(20) (18)**  
 \*Fijar accesorio ( **A** ) y accesorio ( **Y1** ) con el accesorio ( **N** ) a pieza **(20) (18)**  
 \*Fixe o acessório ( **A** ) e o acessório ( **Y1** ) com o acessório ( **N** ) na peça **(20) (18)**

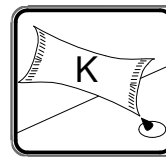
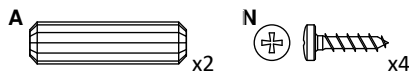
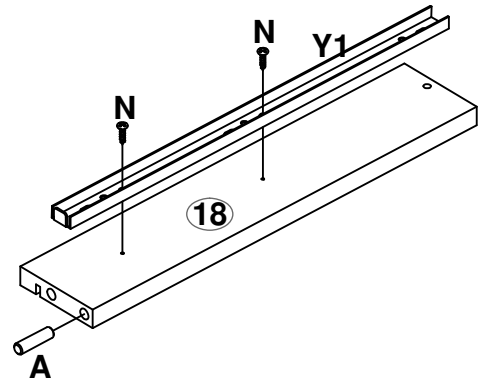
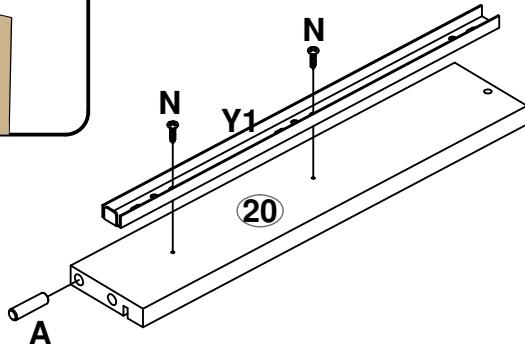
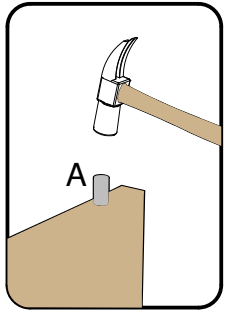

**\*Note:** add glue (K) in the holes before placing the wooden dowel.  
**\*Remarque:** ajouter de la colle (K) dans les trous avant de placer la cheville en bois  
**\*Nota:** agregue el pegamento (K) en los agujeros antes de colocar el taquete.  
**\*Nota:** utilize a cola (K) antes da colocação das Cavilhas.

- 22 -** \*Fix accessory ( **A** ) and accessory ( **Y1** ) with accessory ( **N** ) to part **(19) (21)**  
 \*Fixez l'accessoire ( **A** ) et l'accessoire ( **Y1** ) avec l'accessoire ( **N** ) à la pièce **(19) (21)**  
 \*Fijar accesorio ( **A** ) y accesorio ( **Y1** ) con el accesorio ( **N** ) a pieza **(19) (21)**  
 \*Fixe o acessório ( **A** ) e o acessório ( **Y1** ) com o acessório ( **N** ) na peça **(19) (21)**

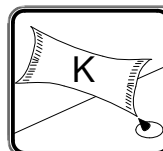
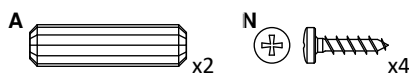
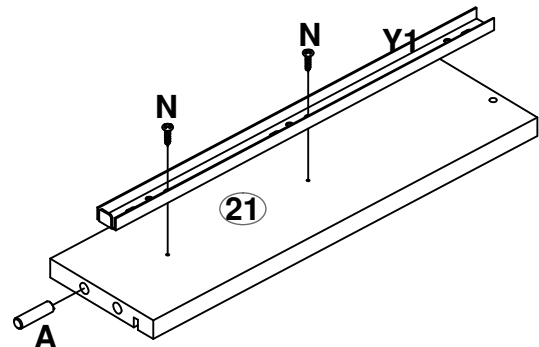
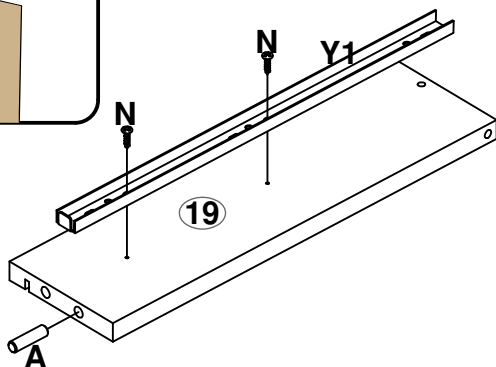
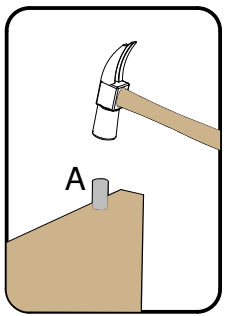

**\*Note:** add glue (K) in the holes before placing the wooden dowel.  
**\*Remarque:** ajouter de la colle (K) dans les trous avant de placer la cheville en bois  
**\*Nota:** agregue el pegamento (K) en los agujeros antes de colocar el taquete.  
**\*Nota:** utilize a cola (K) antes da colocação das Cavilhas.

# ASSEMBLY - MONTAGE - ARMADO - MONTAGEM

- 23 - \*Fix part 02, part 05 and part 06 with the accessory ( H ).  
\*Fixez la pièce 02, la pièce 05 et la pièce 06 avec l'accessoire ( H ).  
\*Fijar pieza 02, pieza 05, y pieza 06 con el accesorio ( H ).  
\*Fixe a peça 02, a peça 05 e a peça 06 com o acessório ( H ).

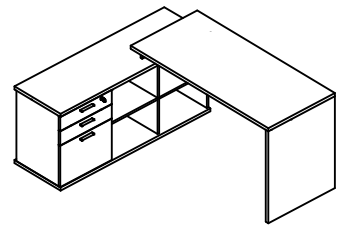
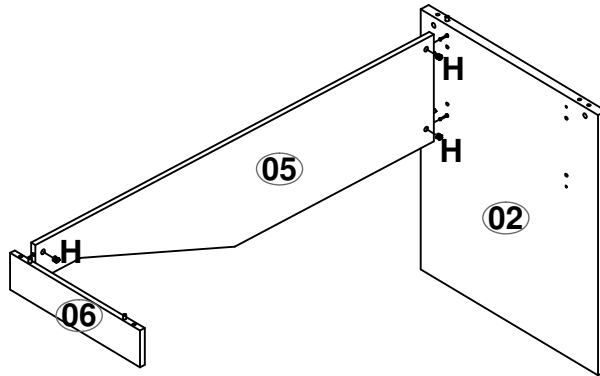
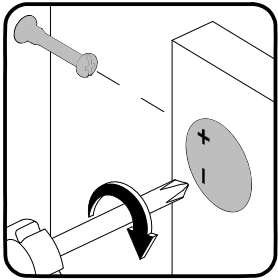

- 24 - \*Fix part 02, part 05 and part 06 with the accessory ( H ).  
\*Fixez la pièce 02, la pièce 05 et la pièce 06 avec l'accessoire ( H ).  
\*Fijar pieza 02, pieza 05, y pieza 06 con el accesorio ( H ).  
\*Fixe a peça 02, a peça 05 e a peça 06 com o acessório ( H ).

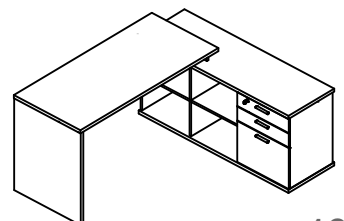
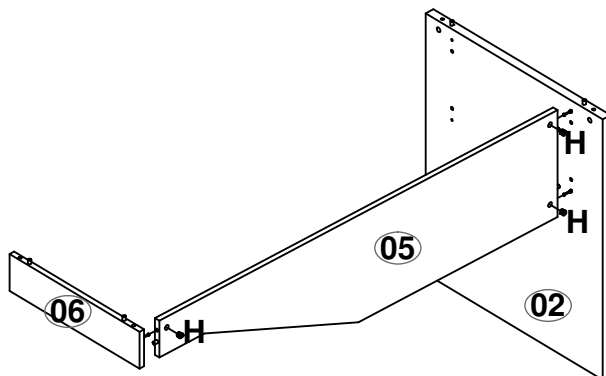
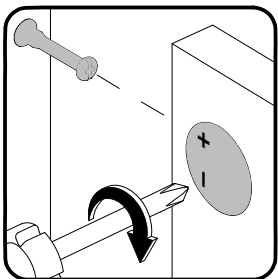

- 25 - \*Fix part **01** to previous assembly with the accessory ( **H** ).  
 \*Fixez la pièce **01** à l'assemblage précédent avec l'accessoire ( **H** ).  
 \*Fijar pieza **01** a ensamble previo con el accesorio ( **H** ).  
 \*Fixe a peça **01** na montagem anterior com o acessório ( **H** ).

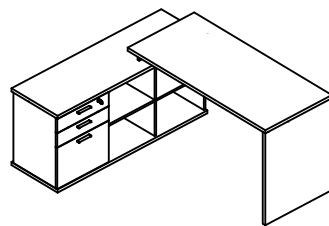
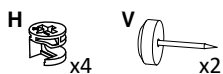
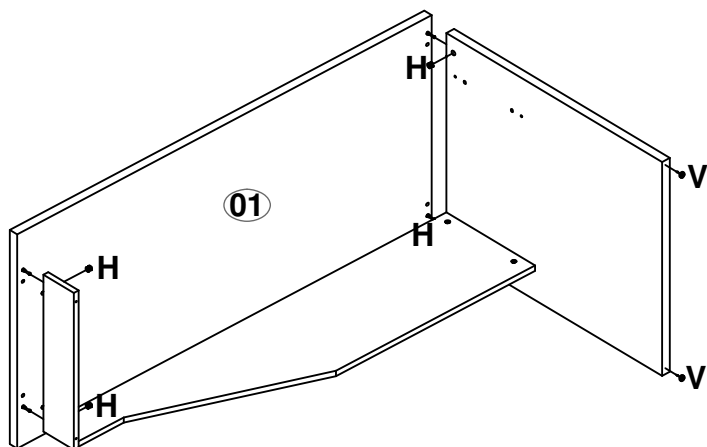
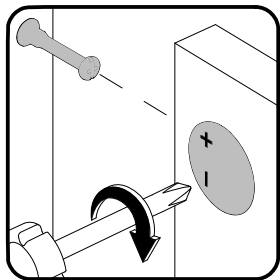

- 26 - \*Fix part **01** to previous assembly with the accessory ( **H** ).  
 \*Fixez la pièce **01** à l'assemblage précédent avec l'accessoire ( **H** ).  
 \*Fijar pieza **01** a ensamble previo con el accesorio ( **H** ).  
 \*Fixe a peça **01** na montagem anterior com o acessório ( **H** ).

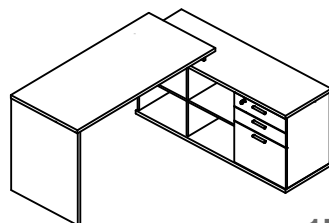
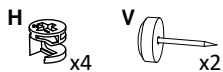
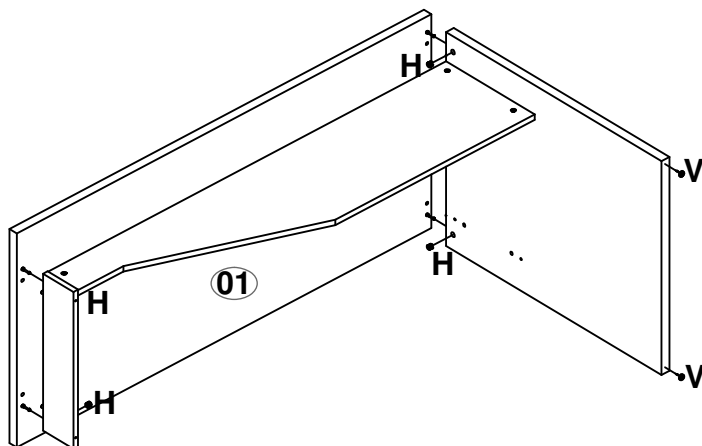
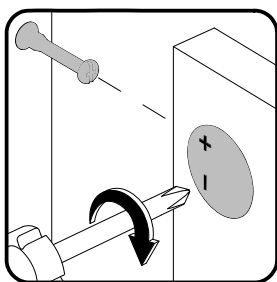

- 27 - \*Fix part 07, part 08, part 09, part 10 and part 12 .  
 \*Fixez la pièce 07, la pièce 08, la pièce 09, la pièce 10 et la pièce 12 .  
 \*Fijar pieza 07, pieza 08, pieza 09, pieza 10 y pieza 12 .  
 \*Fixe a peça 07, a peça 08, a peça 09, a peça 10 e a peça 12 .

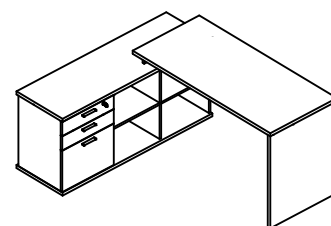
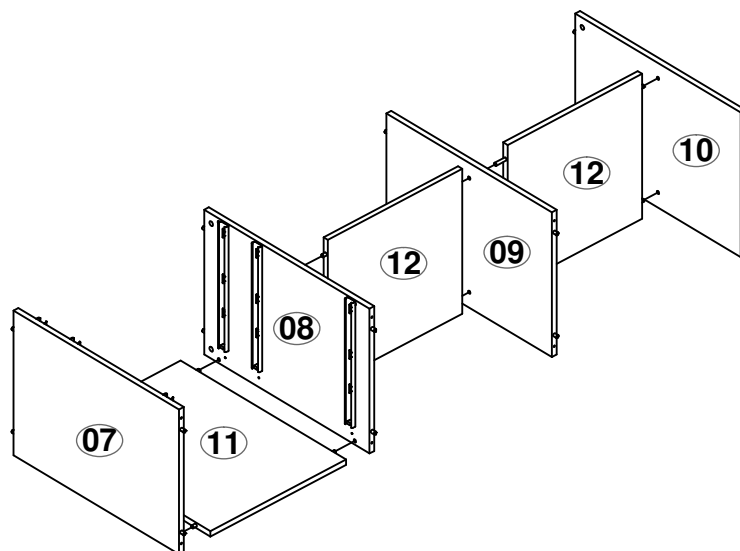

- 28 - \*Fix part 07, part 08, part 09, part 10 and part 12 .  
 \*Fixez la pièce 07, la pièce 08, la pièce 09, la pièce 10 et la pièce 12 .  
 \*Fijar pieza 07, pieza 08, pieza 09, pieza 10 y pieza 12 .  
 \*Fixe a peça 07, a peça 08, a peça 09, a peça 10 e a peça 12 .

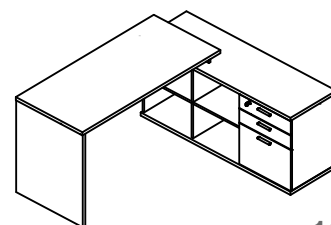
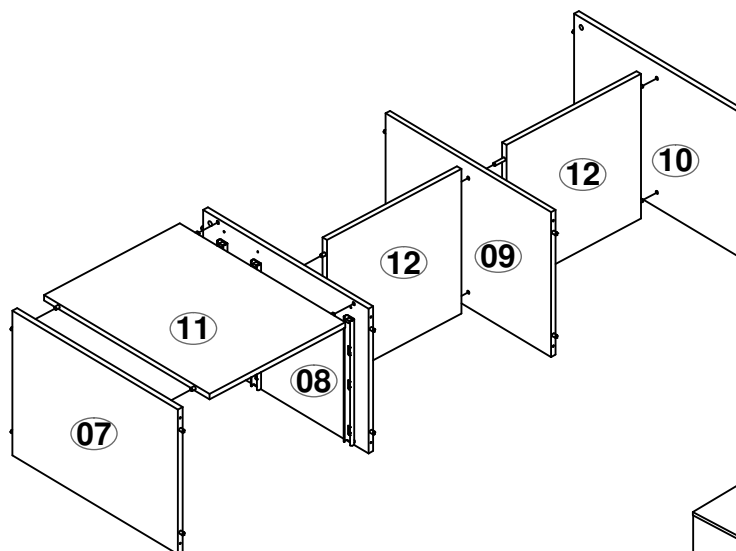

- 29** - \*Fix part **03** to previous assembly with the accessory ( **H** ) and part **04** with the accessory ( **B** ).  
 \*Fixez la pièce **03** à l'assemblage précédent avec l'accessoire ( **H** ) et la pièce **04** avec l'accessoire ( **B** ).  
 \*Fijar pieza **03** a ensamble previo con el accesorio ( **H** ) y pieza **04** con el accesorio ( **B** ).  
 \*Fixe a peça **03** na montagem anterior com o acessório ( **H** ) e a peça **04** com o acessório ( **B** ).

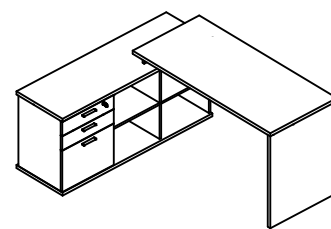
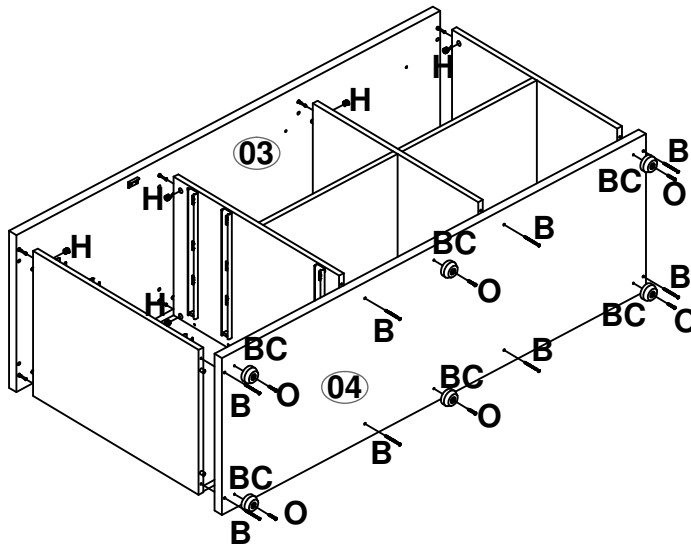
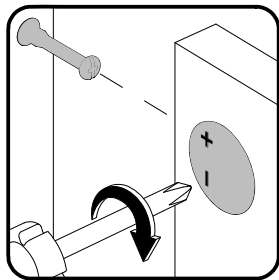

- 30** - \*Fix part **03** to previous assembly with the accessory ( **H** ) and part **04** with the accessory ( **B** ).  
 \*Fixez la pièce **03** à l'assemblage précédent avec l'accessoire ( **H** ) et la pièce **04** avec l'accessoire ( **B** ).  
 \*Fijar pieza **03** a ensamble previo con el accesorio ( **H** ) y pieza **04** con el accesorio ( **B** ).  
 \*Fixe a peça **03** na montagem anterior com o acessório ( **H** ) e a peça **04** com o acessório ( **B** ).

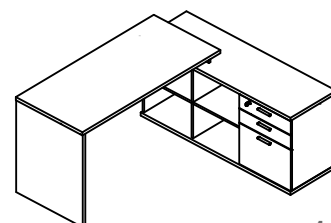
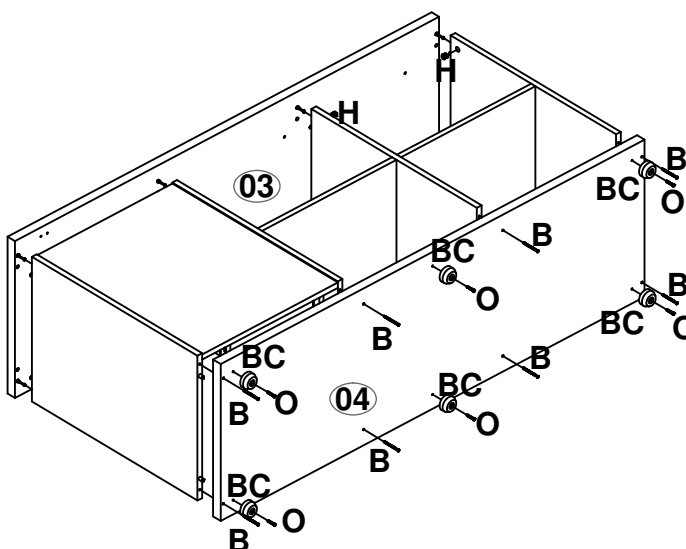
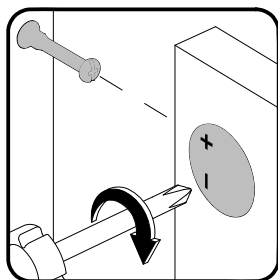

- 31 -** \*Fix previously assemblies (steps **25** and **29**) with the accessory ( **B** ).  
\*Fixez assemblages précédents (étapes **25** et **29**) avec l'accessoire ( **B** ).  
\*Fijar ensambles previos (pasos **25** y **29**) con el accesorio ( **B** ).  
\*Junte as montagens anteriores (passos **25** e **29**) com o acessório ( **B** ).

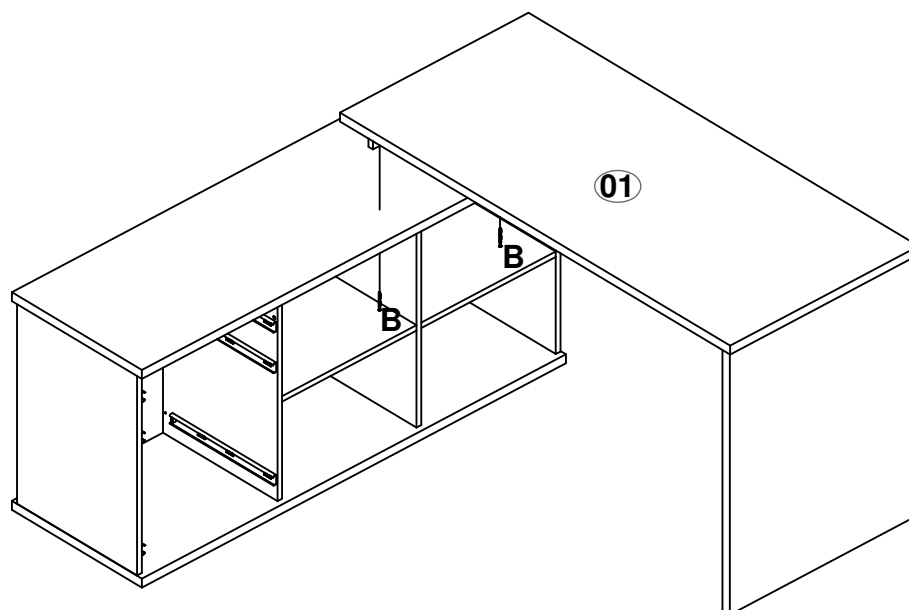

- 32 -** \*Fix previously assemblies (steps **26** and **30**) with the accessory ( **B** ).  
\*Fixez assemblages précédents (étapes **26** et **30**) avec l'accessoire ( **B** ).  
\*Fijar ensambles previos (pasos **26** y **30**) con el accesorio ( **B** ).  
\*Junte as montagens anteriores (passos **26** e **30**) com o acessório ( **B** ).

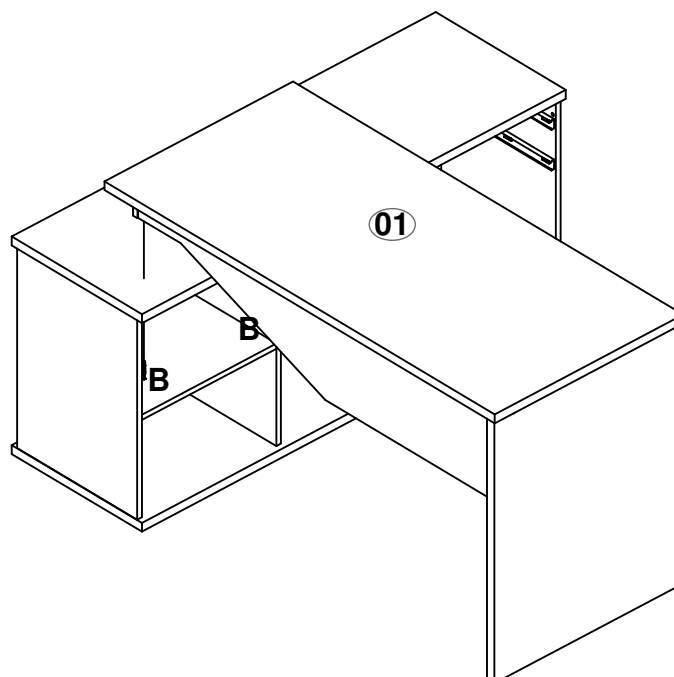

- 33 -** \*Fix part **16**, part **19** and part **21** with the accessory ( **B** ).  
 \*Fixez la pièce **16**, la pièce **19** et la pièce **21** avec l'accessoire ( **B** ).  
 \*Fijar pieza **16**, pieza **19**, y pieza **21** con el accesorio ( **B** ).  
 \*Fixe a peça **16**, a peça **19** e a peça **21** com o acessório ( **B** ).

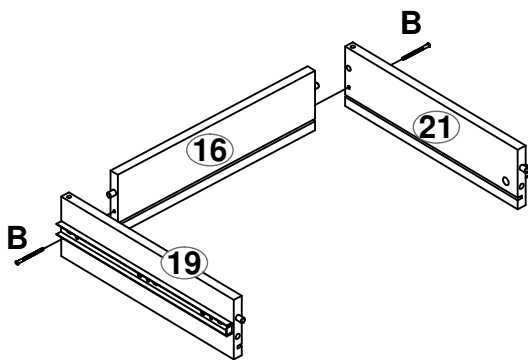

- 34 -** \*Fix part **13** and part **22** to previous assembly with the accessory ( **H** ).  
 \*Fixez la pièce **13** et la pièce **22** à l'assemblage précédent avec l'accessoire ( **H** ).  
 \*Fijar pieza **13** y pieza **22** a ensamble previo con el accesorio ( **H** ).  
 \*Fixe a peça **13** e a peça **22** na montagem anterior com o acessório ( **H** ).

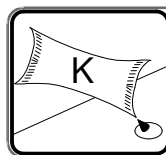
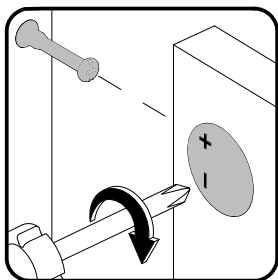

**\*Note:** add glue (K) in the holes before placing the wooden dowel.  
**\*Remarque:** ajouter de la colle (K) dans les trous avant de placer la cheville en bois.  
**\*Nota:** agregue el pegamento (K) en los agujeros antes de colocar el taquete.  
**\*Nota:** utilize a cola (K) antes da colocação das Cavilhas.

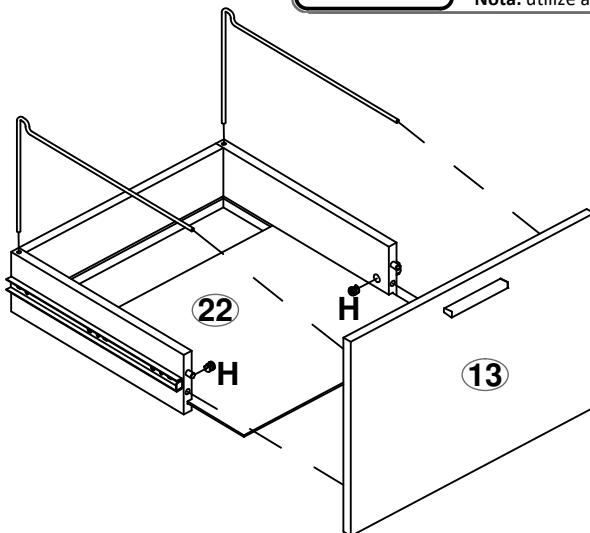

- 35 -** \*Fix part **17**, part **18** and part **20** with the accessory ( **B** ).  
 \*Fixez la pièce **17**, la pièce **18** et la pièce **20** avec l'accessoire ( **B** ).  
 \*Fijar pieza **17**, pieza **18**, y pieza **20** con el accesorio ( **B** ).  
 \*Fixe a peça **17**, a peça **18** e a peça **20** com o acessório ( **B** ).

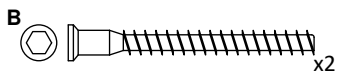
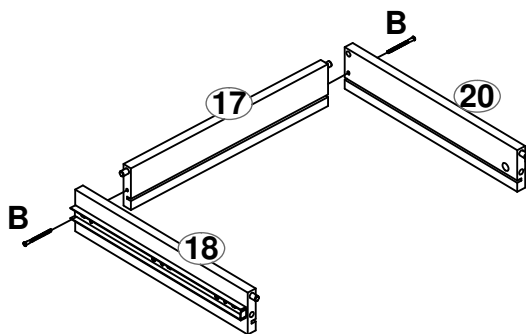

- 36 -** \*Fix part **14** and part **22** to previous assembly with the accessory ( **H** ).  
 \*Fixez la pièce **14** et la pièce **22** à l'assemblage précédent avec l'accessoire ( **H** ).  
 \*Fijar pieza **14** y pieza **22** a ensamble previo con el accesorio ( **H** ).  
 \*Fixe a peça **14** e a peça **22** na montagem anterior com o acessório ( **H** ).

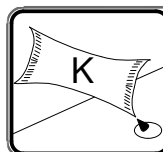
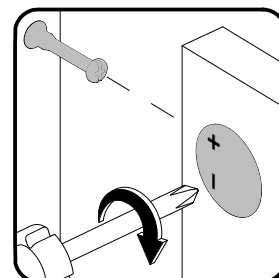
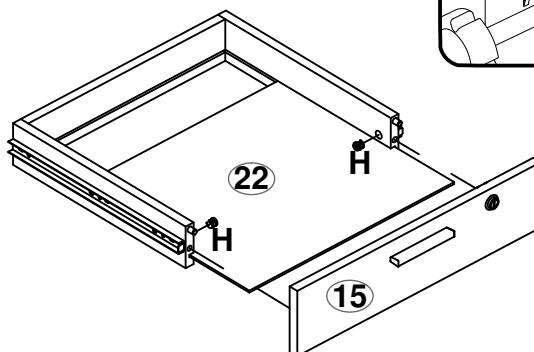
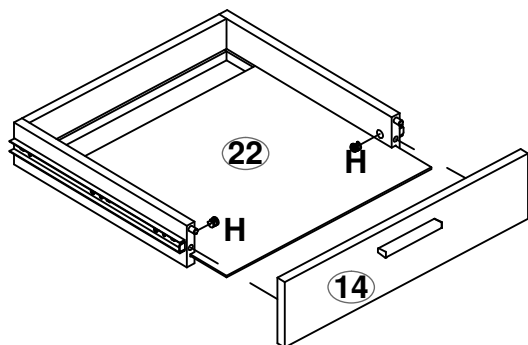

- \*Note: add glue (K) in the holes before placing the wooden dowel.  
 \*Remarque: ajouter de la colle (K) dans les trous avant de placer la cheville en bois  
 \*Nota: agregue el pegamento (K) en los agujeros antes de colocar el taquete.  
 \*Nota: utilize a cola (K) antes da colocação das Cavilhas.

- 37 -** \*Fix previously assemblies (steps **31** and **36**).  
 \*Fixez assemblages précédents (étapes **31** et **36**).  
 \*Fijar ensambles previos (pasos **31** y **36**).  
 \*Junte as montagens anteriores (passos **31** e **36**).

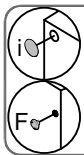
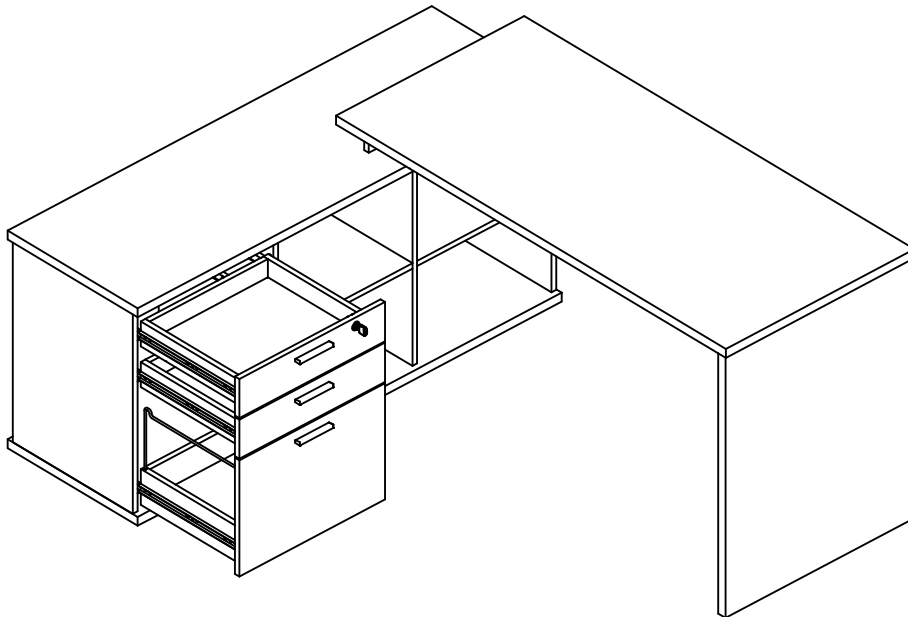

**\*Note:** Use the stickers and caps to finish.

**\*Remarque:** Utiliser les autocollants et les capuchons pour terminer la finition.

**\*Nota:** Utilice los adhesivos y tapas para finalizar el acabado.

**\*Nota:** Utilize os adesivos e tampas para finalizar o acabamento.

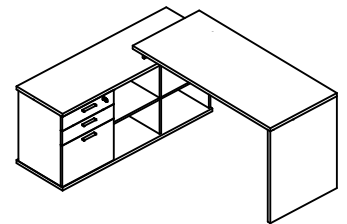

- 38 -** \*Fix previously assemblies (steps **32** and **36**).  
 \*Fixez assemblages précédents (étapes **32** et **36**).  
 \*Fijar ensambles previos (pasos **32** y **36**).  
 \*Junte as montagens anteriores (passos **32** e **36**).

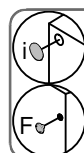
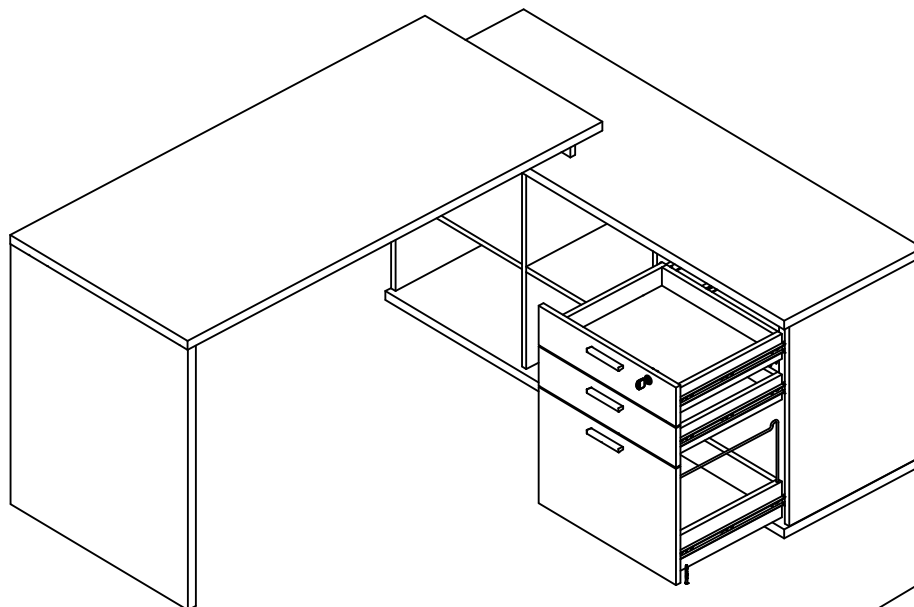

**\*Note:** Use the stickers and caps to finish.

**\*Remarque:** Utiliser les autocollants et les capuchons pour terminer la finition.

**\*Nota:** Utilice los adhesivos y tapas para finalizar el acabado.

**\*Nota:** Utilize os adesivos e tampas para finalizar o acabamento.

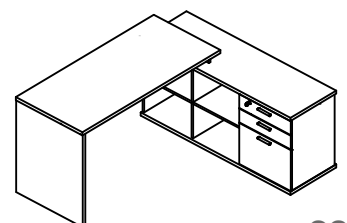

# Agora que você já comprou o seu móvel, ele merece ser montado do jeito certo.

Erros de montagem causam mais de **60%** dos danos em móveis.

## Por que contratar?

Tranquilidade do **início ao fim** da montagem



### PROFISSIONAIS QUALIFICADOS

Especialistas certificados na **MadeiraMadeira Serviços**.



### FERRAMENTAS PROFISSIONAIS

que **protegem** seus móveis.



### AGENDAMENTO EM 24 HORAS

escolha a data e o turno **ideais para** você.



### GARANTIA DE 3 MESES

de cobertura **completa**.

**Mais de 1 MILHÃO DE MONTAGENS**  
★ com avaliação **4.7** ★

#### Mariana S., São Paulo

"Chegaram no horário e montaram tudo rapidamente. Serviço incrível!"



#### Carlos R., Belo Horizonte

"Tentei montar sozinho e foi um desastre. Com a **MadeiraMadeira Serviços** ficou perfeito."



#### Ana P., Rio de Janeiro

"Agendamento ágil e **montagem pontual e perfeita**. Recomendo demais!"



## Agende agora pelo QR Code

Madeira**Madeira** Serviços · Atendimento em todo o Brasil



Escaneie o QRCode