

ASSEMBLY INSTRUCTIONS

Ref.: 200658 - ELB0061.01

Review 01

INSTRUCTIONS DE MONTAGE | MANUAL DE ARMADO | ESQUEMA DE MONTAGEM

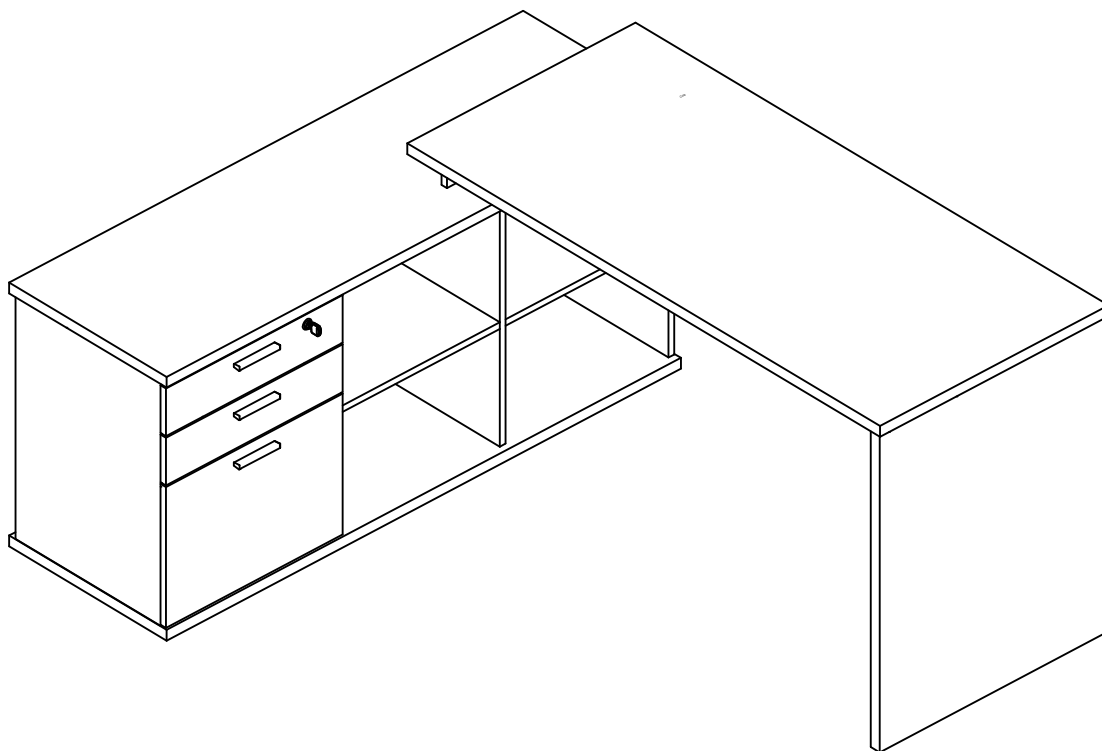

YOU WILL NEED

TU AURAS BESOIN DE | NECESITARÁ | VOCÊ VAI PRECISAR

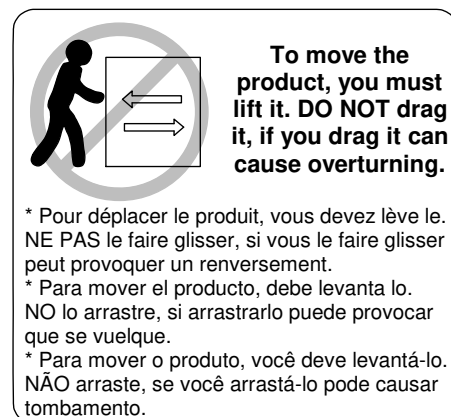
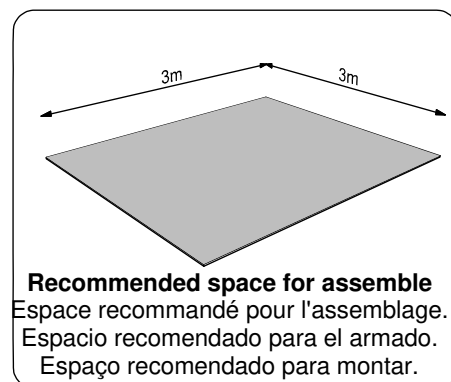
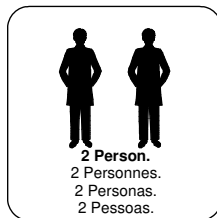
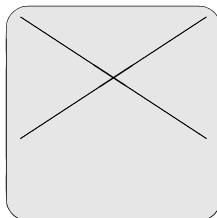
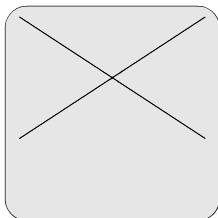
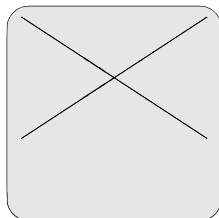
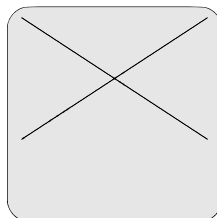
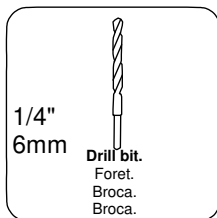
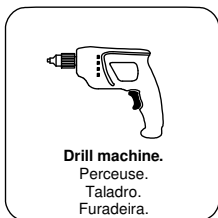
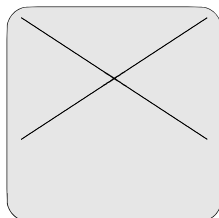
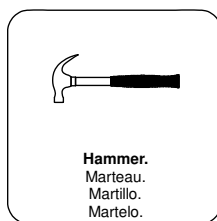
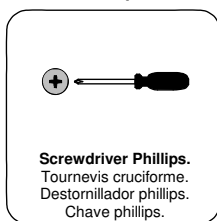
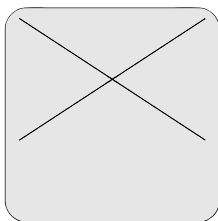
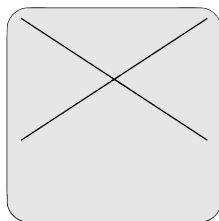

Tools not included

Outils non inclus | Herramientas no incluidas | Ferramentas não inclusas

PARTS IDENTIFICATION

IDENTIFICATION DES PIÈCES | IDENTIFICACIÓN DE PIEZAS | IDENTIFICAÇÃO DAS PEÇAS

01	Top Plan de Travail Tapa Tampo	Qty./Qtd. 01
02	Side Côté Lateral Lateral	Qty./Qtd. 01
03	Top Base Base Supérieure Base Superior Base Superior	Qty./Qtd. 01
04	Bottom Base Base Inférieure Base Inferior Base Inferior	Qty./Qtd. 01
05	Panel Panneau Panel Painel	Qty./Qtd. 01
06	Top holder Support supérieur Titular superior Suporte Tampo	Qty./Qtd. 01
07	Left Side Côté Gauche Lateral Izquierdo Lateral Esquerda	Qty./Qtd. 01
08	Left Division Division Gauche División Izquierda Divisória Esquerda	Qty./Qtd. 01
09	Right Division Division Droite División Derecha Divisória Direita	Qty./Qtd. 01
10	Right Side Côté Droite Lateral Derecho Lateral Direita	Qty./Qtd. 01
11	Vertical Panel Panneau Vertical Panel Vertical Painel Vertical	Qty./Qtd. 01
12	Shelf Étagère Repisa Prateleira	Qty./Qtd. 02

13	Bigger Drawer Front Plus Grand Tiroir Avant Frente Mayor Del Cajón Frente de Gaveta Maior	Qty./Qtd. 01
14	Smaller Drawer Front Plus Petit Tiroir Avant Frente Menor del Cajón Frente de Gaveta Menor	Qty./Qtd. 01
15	Drawer Front Avant de Tiroir Frente del Cajón Frente de Gaveta	Qty./Qtd. 01
16	Bigger Rear of Drawer Plus Grand Arrière du Tiroir Posterior de Cajón Mayor Traseiro de Gaveta Maior	Qty./Qtd. 01
17	Smaller Rear of Drawer Plus Petit Arrière du Tiroir Posterior de Cajón Menor Traseiro de Gaveta Menor	Qty./Qtd. 02
18	Left Side of Drawer Côté Gauche du Tiroir Lateral Izquierdo de Cajón Lateral Esquerda de Gaveta	Qty./Qtd. 02
19	Bigger Left Side of Drawer Plus Grand Côté Gauche du Tiroir Lateral Izquierdo Mayor de Cajón Lateral de Gaveta Esquerda Maior	Qty./Qtd. 01
20	Right Side of Drawer Côté Droite du Tiroir Lateral Derecho de Cajón Lateral Direita de Gaveta	Qty./Qtd. 02
21	Bigger Right Side of Drawer Plus Grand Côté Droite du Tiroir Lateral Derecho Mayor de Cajón Lateral de Gaveta Direita Maior	Qty./Qtd. 01
22	Backboard of drawer Arrière du Tiroir Fondo de cajón Fundo de Gaveta	Qty./Qtd. 03

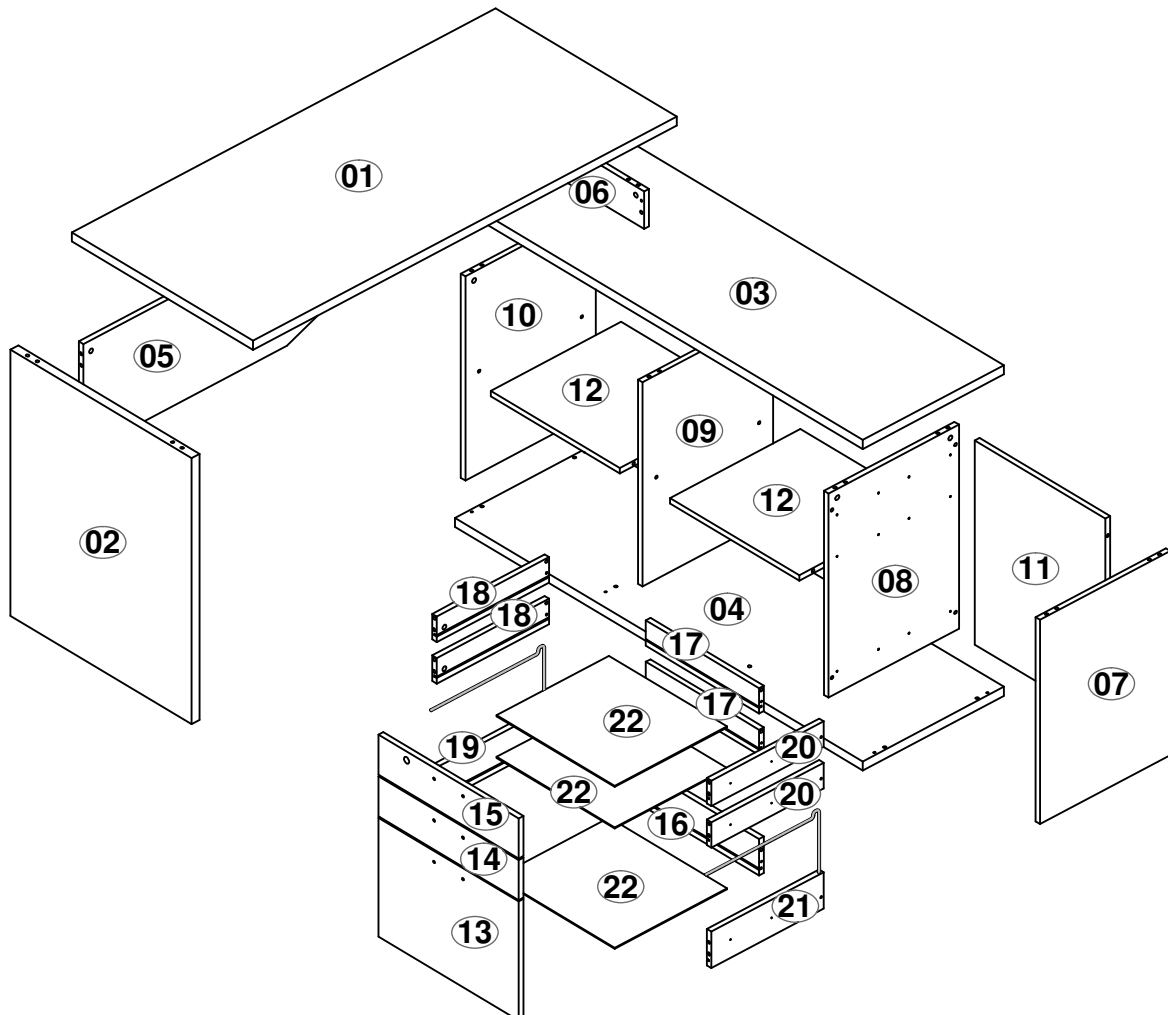

GENERAL DIMENSIONS | DIMENSIONS GÉNÉRALES | DIMENSIONES GENERALES | DIMENSÕES

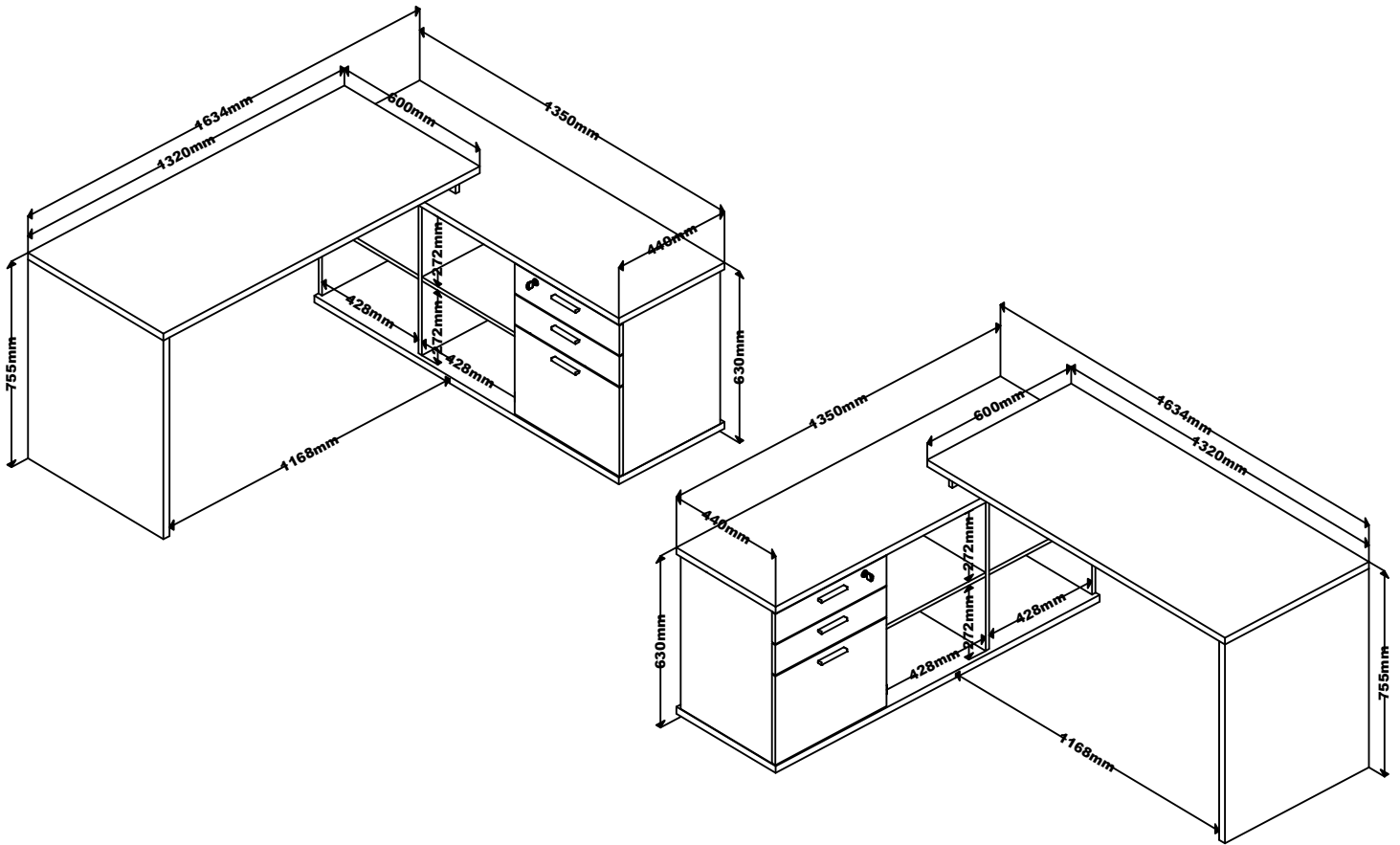

MAXIMUM RECOMMENDED WEIGHT BEING THIS EVENLY DISTRIBUTED.
 LE POIDS MAXIMAL RECOMMANDÉ EST RÉGULIÈREMENT DISTRIBUÉ.
 PESO MÁXIMO RECOMENDADO SIENDO ESTO UNIFORME REPARTIDO.
 PESO MÁXIMO RECOMENDADO SENDO ESTE DISTRIBUIDO.

	LB	KG
A	66	30
B	22	10

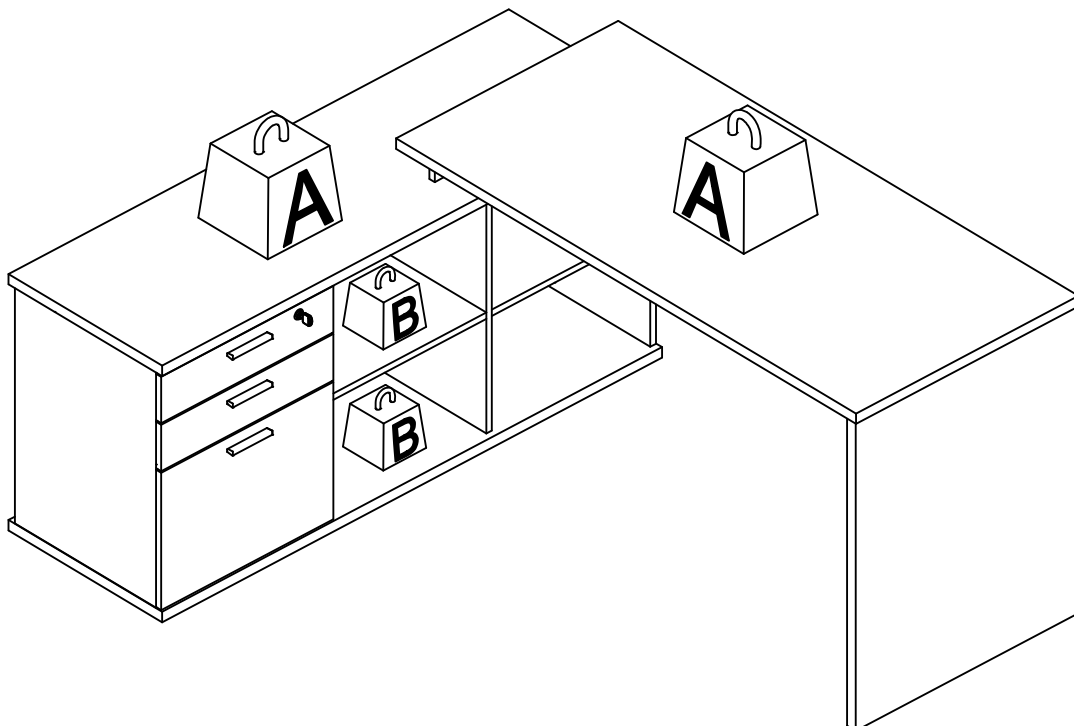

ACCESSORIES IDENTIFICATION

IDENTIFICATION DES ACCESSOIRES | IDENTIFICACIÓN DE ACCESORIOS | IDENTIFICAÇÃO DOS ACESSÓRIOS

A  Qty./Qtd. **43**
Wooden dowel / Chevilles en bois / Taquete / Caviha

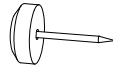
V  Qty./Qtd. **2**
Small plastic foot / Chaussure de glisse / Pie plástico / Sapata Plástica

AD  Qty./Qtd. **1**
Allen key / Clé Allen / Liave allen / Chave Allen

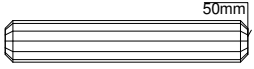
AM  Qty./Qtd. **2**
Wooden dowel / Chevilles en bois / Taquete / Caviha

B  Qty./Qtd. **16**
Structural screw / Vis à tête structurelle / Tornillo estructural / Parafuso Estructural

BC  Qty./Qtd. **6**
Plastic foot / Pied en Plastique / Pie plástico / Sapata Plástica

BH  Qty./Qtd. **1**
Lock / Serrure / Cerrar / Fechadura

BK  Qty./Qtd. **1**
Door stop / Heurtoir / Tope de puerta / Batente

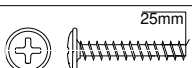
D  Qty./Qtd. **6**
Flanged head screw / Vis à tête bride / Tornillo de cabeza flangeada / Parafuso Flangeado

F  Qty./Qtd. **16**
Structural screw cover/Cache-vis structurel/Tapa tornillo estructural/ Tampa estrutural

G  Qty./Qtd. **21**
Simple minifix screw / Vis minifix simple / Tornillo minifix simple / Haste Minifix Simples

H  Qty./Qtd. **21**
Drum lock / Verrouillage du tambour / Tambor minifix / Tambor de Minifix

i  Qty./Qtd. **21**
Bore patch adhesive / Adhésif de correction d'alésage / Tapones adhesivo/ Adesivo Tapa Furo

K  Qty./Qtd. **1**
Glue / Colle / Pegamento / Bisnaga de Cola

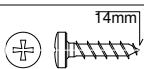
N  Qty./Qtd. **28**
Pan head screw / Vis à tête bombée / Tornillo de pan / Parafuso Panela

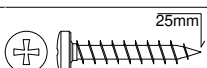
O  Qty./Qtd. **6**
Pan head screw / Vis à tête bombée / Tornillo de pan / Parafuso Panela

Separating the accessories before starting the assembly will make it easier.

Séparer les accessoires avant de commencer le montage vous facilitera la tâche.

Separar los accesorios antes de comenzar el montaje lo hará más fácil.

Separar os acessórios antes de iniciar a montagem facilitará.

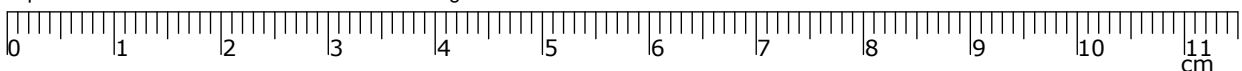

PRE-ASSEMBLY - PRÉ-ASSEMBLAGE - PRE-ARMADO PRÉ-MONTAGEM

- 01 - *Fix accessory (**G**) and accessory (**N**) to part 03 .
*Fixez l'accessoire (**G**) et l'accessoire (**N**) à la pièce 03 .
*Fijar accesorio (**G**) y accesorio (**N**) a pieza 03 .
*Fixe o acessório (**G**) e o acessório (**N**) na peça 03 .

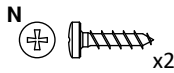
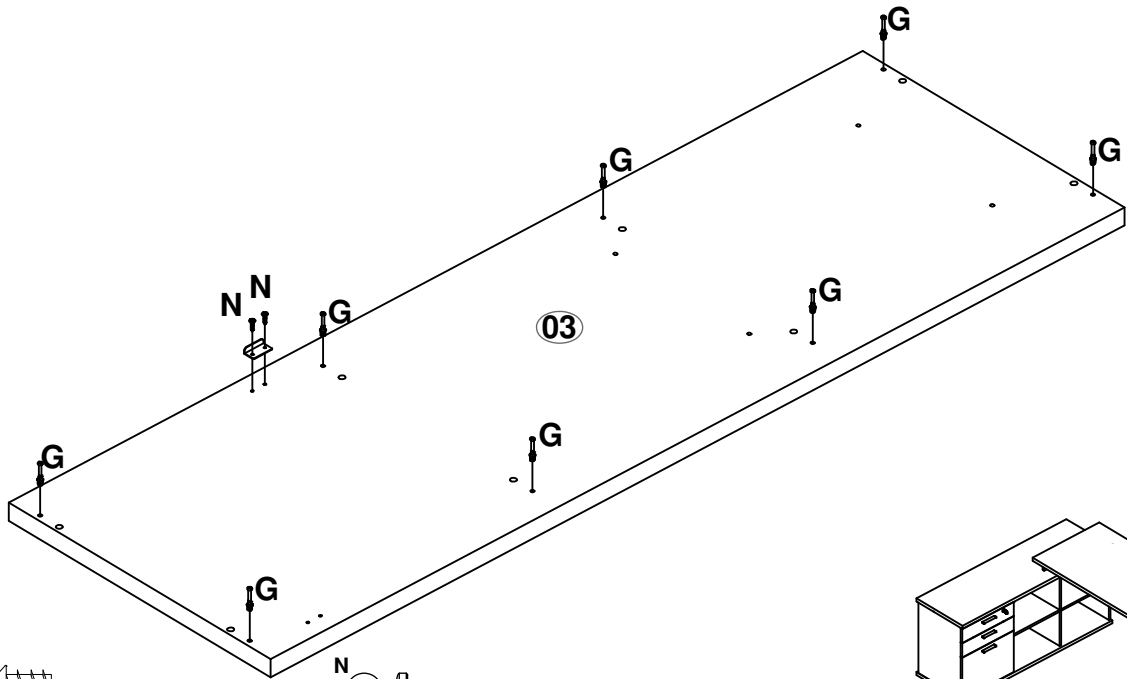
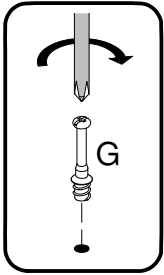

- 02 - *Fix accessory (**G**) and accessory (**N**) to part 03 .
*Fixez l'accessoire (**G**) et l'accessoire (**N**) à la pièce 03 .
*Fijar accesorio (**G**) y accesorio (**N**) a pieza 03 .
*Fixe o acessório (**G**) e o acessório (**N**) na peça 03 .

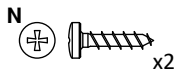
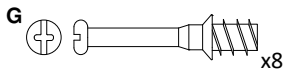
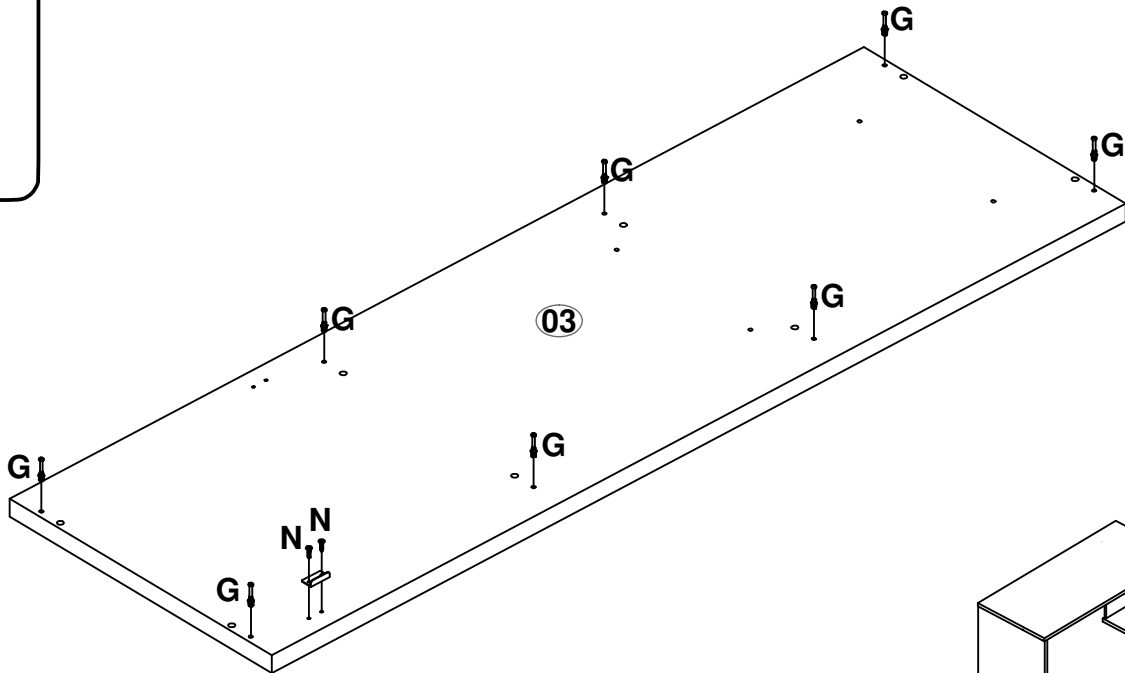
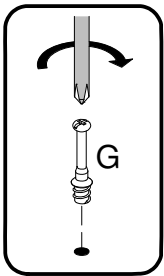

- 03 -** *Fix accessory (**A**) and accessory (**G**) to part **02** .
 *Fixez l'accessoire (**A**) et l'accessoire (**G**) à la pièce **02** .
 *Fijar accesorio (**A**) y accesorio (**G**) a pieza **02** .
 *Fixe o acessório (**A**) e o acessório (**G**) na peça **02** .

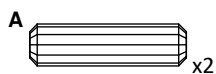
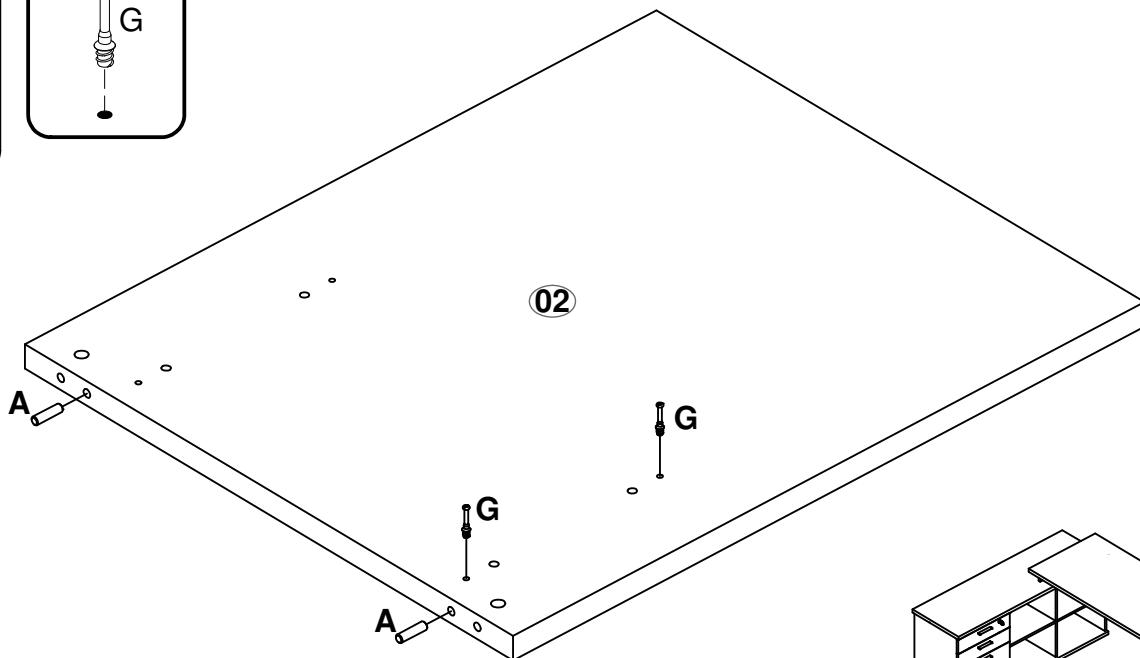
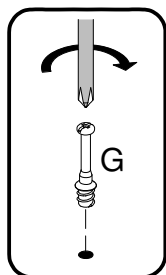
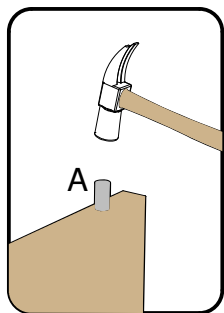

- 04 -** *Fix accessory (**A**) and accessory (**G**) to part **02** .
 *Fixez l'accessoire (**A**) et l'accessoire (**G**) à la pièce **02** .
 *Fijar accesorio (**A**) y accesorio (**G**) a pieza **02** .
 *Fixe o acessório (**A**) e o acessório (**G**) na peça **02** .

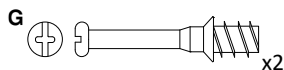
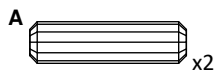
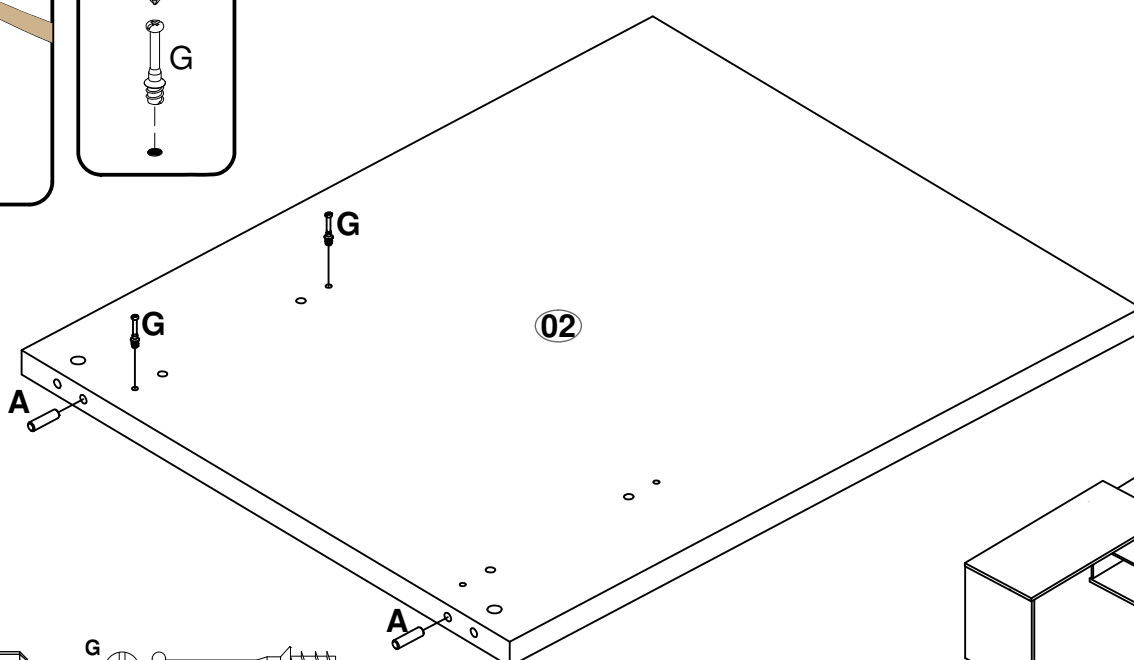
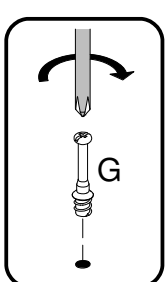
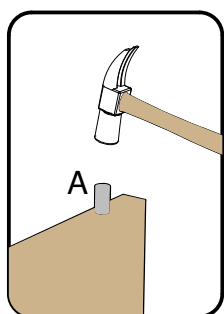

- 05** - *Fix accessory (**G**) and accessory (**A**) to part **06** .
 *Fixez l'accessoire (**G**) et l'accessoire (**A**) à la pièce **06** .
 *Fijar accesorio (**G**) y accesorio (**A**) a pieza **06** .
 *Fixe o acessório (**G**) e o acessório (**A**) na peça **06** .

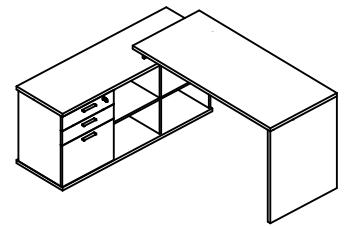
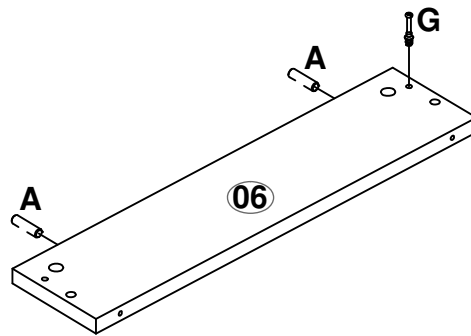
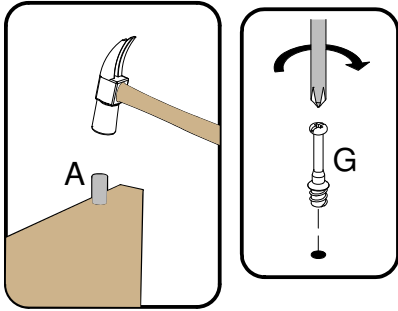

- 06** - *Fix accessory (**G**) and accessory (**A**) to part **06** .
 *Fixez l'accessoire (**G**) et l'accessoire (**A**) à la pièce **06** .
 *Fijar accesorio (**G**) y accesorio (**A**) a pieza **06** .
 *Fixe o acessório (**G**) e o acessório (**A**) na peça **06** .

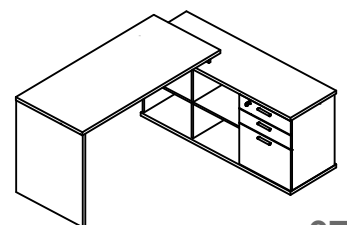
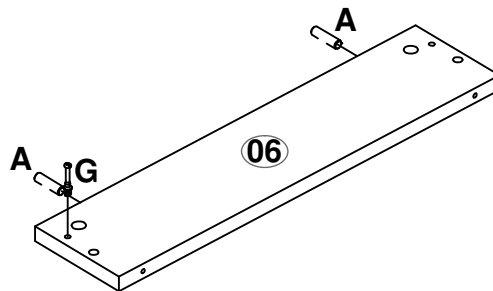
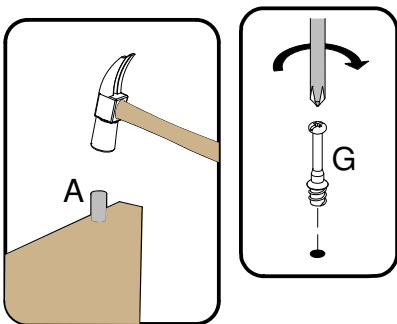

- 07 -** *Fix accessory (**A**) and accessory (**Y2**) with accessory (**N**) to part **07** .
 *Fixez l'accessoire (**A**) et l'accessoire (**Y2**) avec l'accessoire (**N**) à la pièce **07** .
 *Fijar accesorio (**A**) y accesorio (**Y2**) con el accesorio (**N**) a pieza **07** .
 *Fixe o acessório (**A**) e o acessório (**Y2**) com o acessório (**N**) na peça **07** .

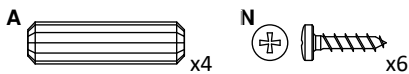
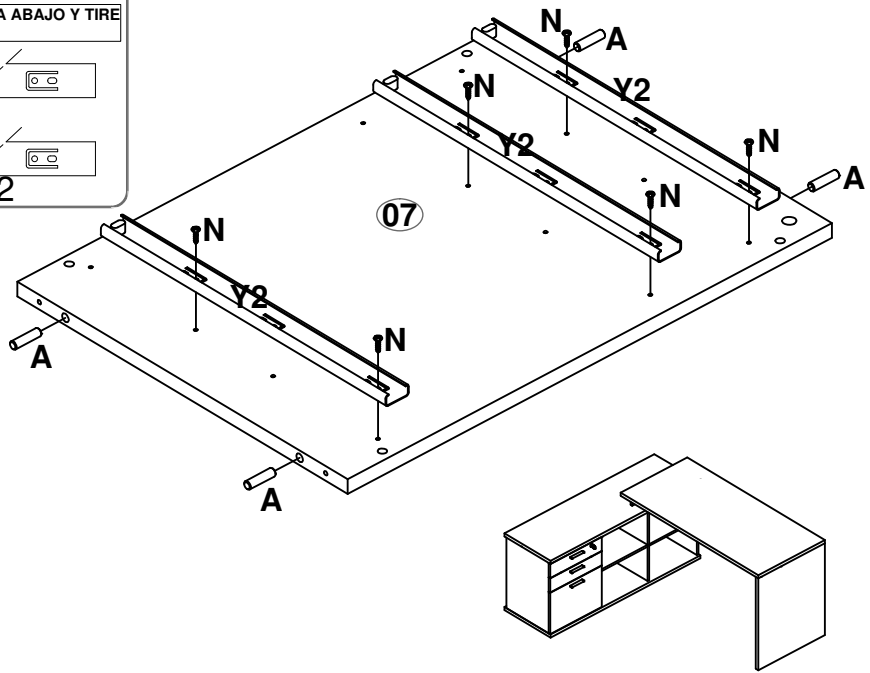
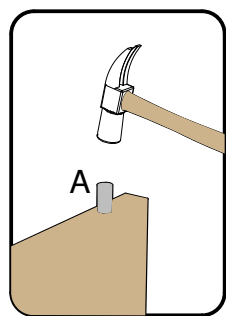
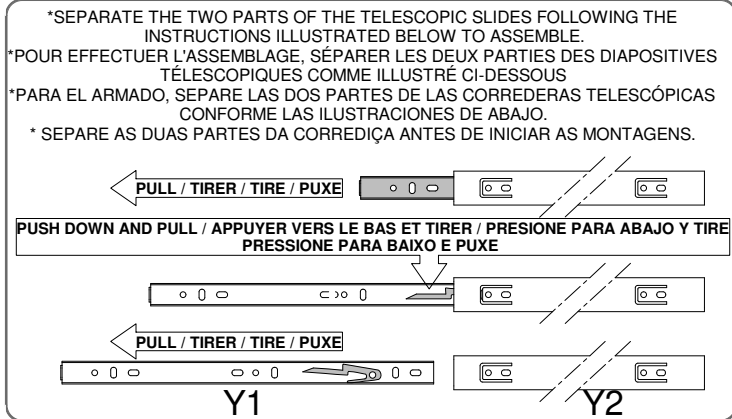

- 08 -** *Fix accessory (**A**) and accessory (**Y2**) with accessory (**N**) to part **07** .
 *Fixez l'accessoire (**A**) et l'accessoire (**Y2**) avec l'accessoire (**N**) à la pièce **07** .
 *Fijar accesorio (**A**) y accesorio (**Y2**) con el accesorio (**N**) a pieza **07** .
 *Fixe o acessório (**A**) e o acessório (**Y2**) com o acessório (**N**) na peça **07** .

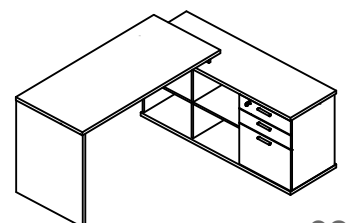
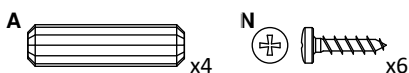
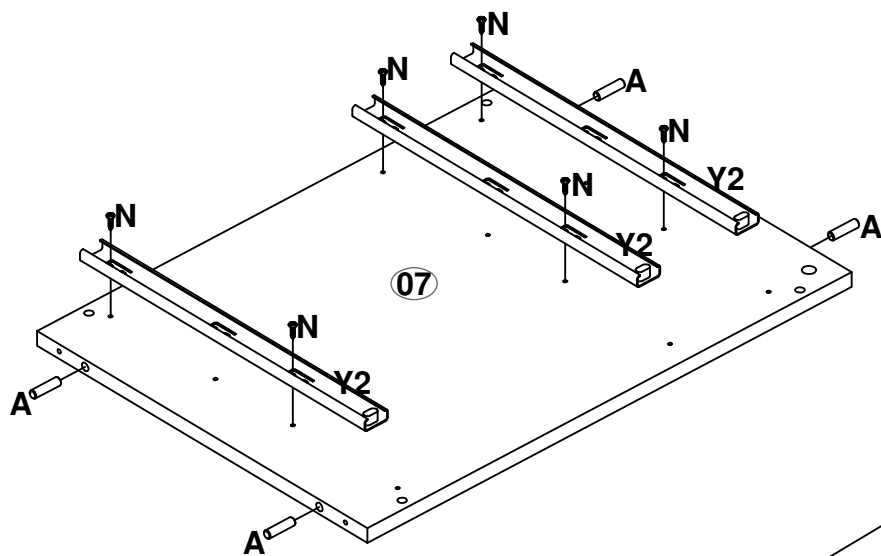
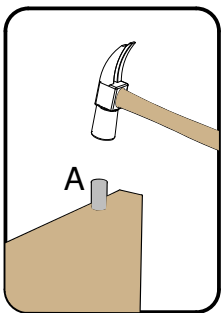

- 09** - *Fix accessory (**A**) and accessory (**Y2**) with accessory (**N**) to part **08** .
 *Fixez l'accessoire (**A**) et l'accessoire (**Y2**) avec l'accessoire (**N**) à la pièce **08** .
 *Fijar accesorio (**A**) y accesorio (**Y2**) con el accesorio (**N**) a pieza **08** .
 *Fixe o acessório (**A**) e o acessório (**Y2**) com o acessório (**N**) na peça **08** .

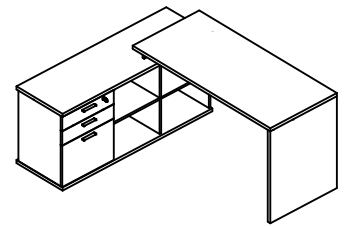
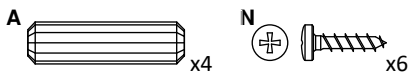
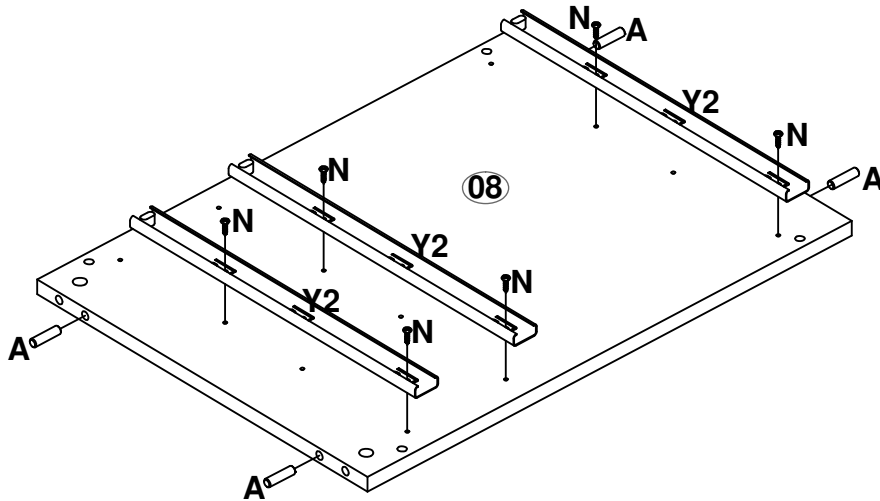
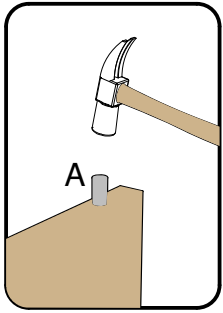

- 10** - *Fix accessory (**A**) and accessory (**Y2**) with accessory (**N**) to part **08** .
 *Fixez l'accessoire (**A**) et l'accessoire (**Y2**) avec l'accessoire (**N**) à la pièce **08** .
 *Fijar accesorio (**A**) y accesorio (**Y2**) con el accesorio (**N**) a pieza **08** .
 *Fixe o acessório (**A**) e o acessório (**Y2**) com o acessório (**N**) na peça **08** .

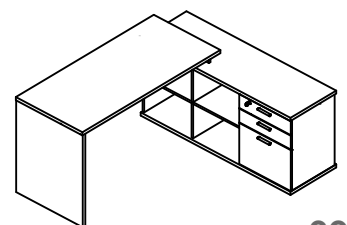
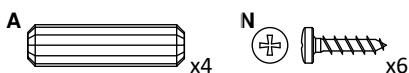
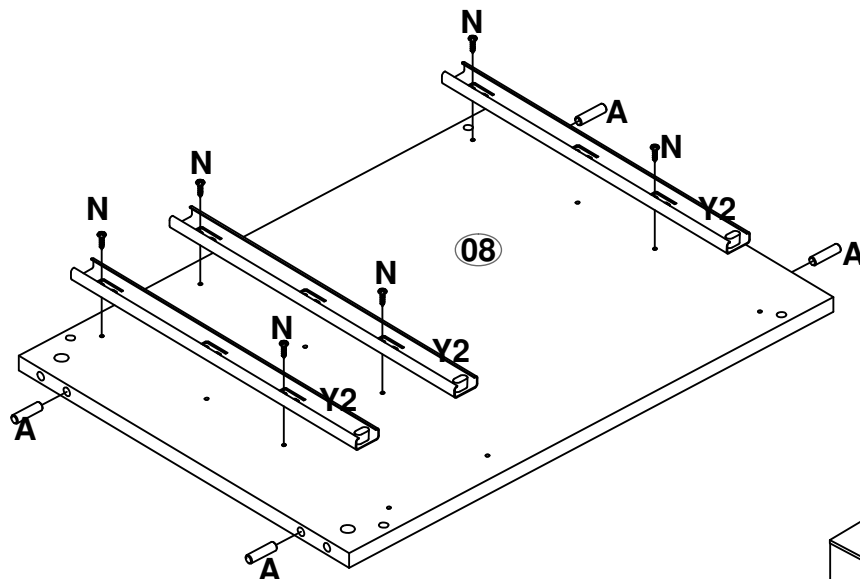
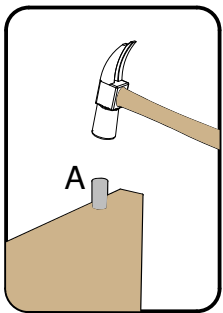

- 11 - *Fix accessory (**G**) to part **01**.
 *Fixez l'accessoire (**G**) à la pièce **01**.
 *Fijar accesorio (**G**) a pieza **01**.
 *Fixe o acessório (**G**) na peça **01**.

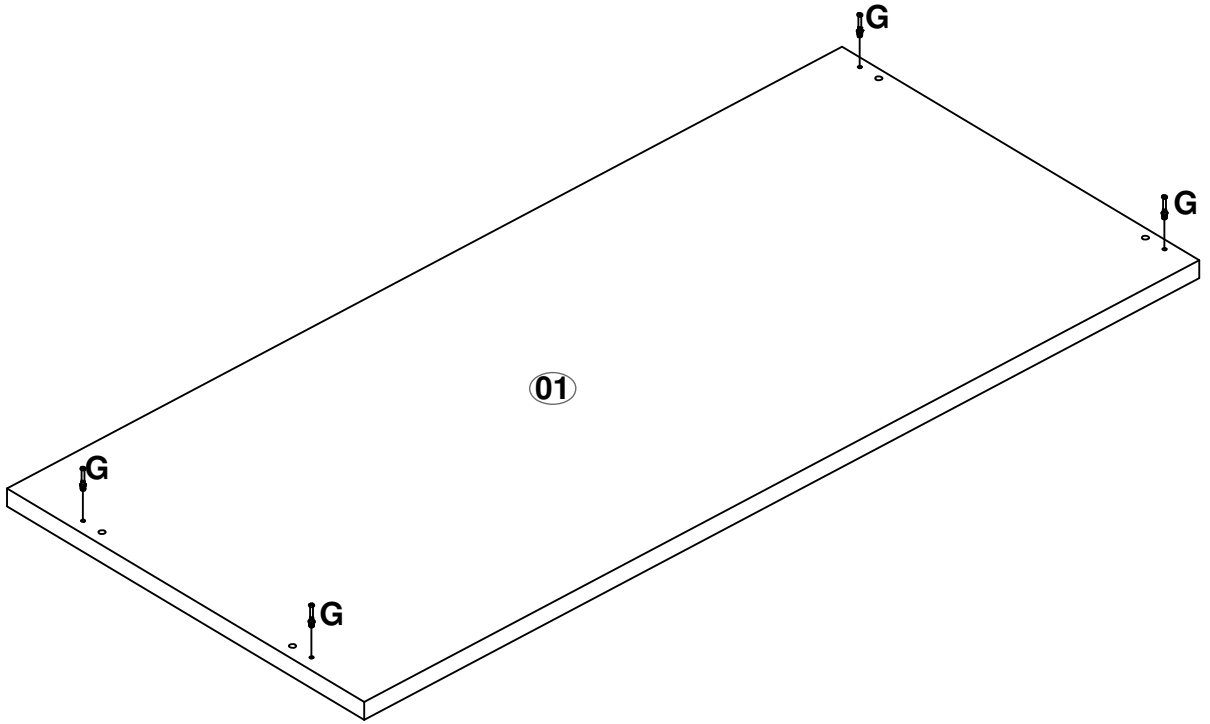
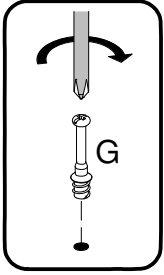

- 12 - *Fix accessory (**A**) to part **05**.
 *Fixez l'accessoire (**A**) à la pièce **05**.
 *Fijar accesorio (**A**) a pieza **05**.
 *Fixe o acessório (**A**) na peça **05**.

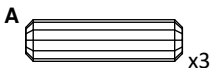
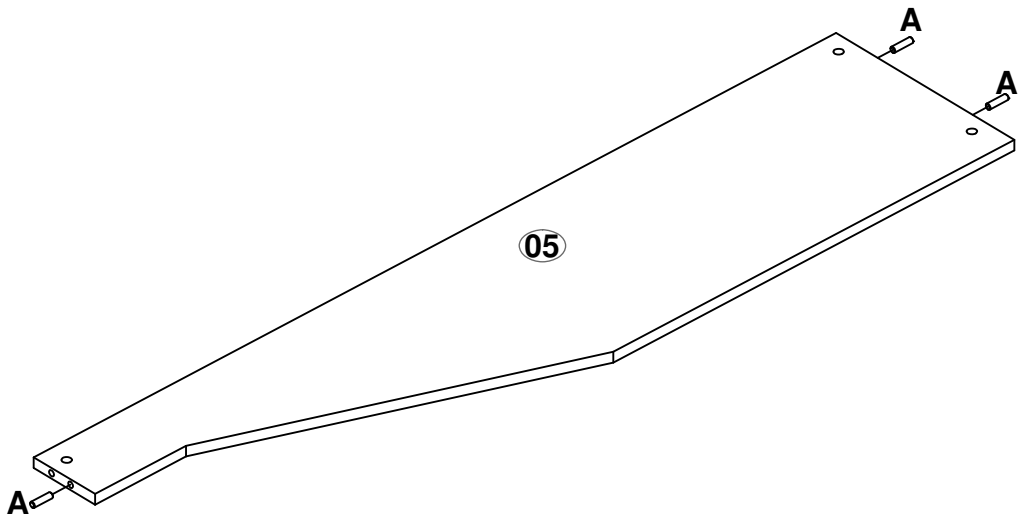
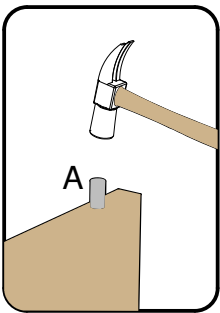

- 13 - *Fix accessory (**A**) to part **11**.
*Fixez l'accessoire (**A**) à la pièce **11**.
*Fijar accesorio (**A**) a pieza **11**.
*Fixe o acessório (**A**) na peça **11**.

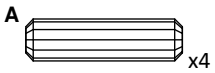
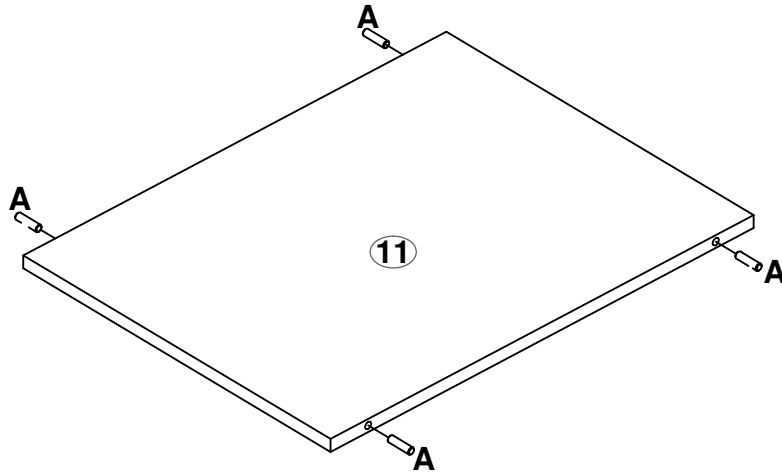
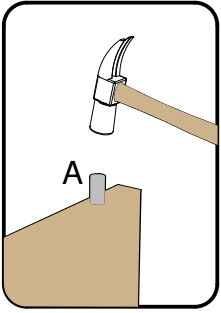

- 14 - *Fix accessory (**A**) to part **09**.
*Fixez l'accessoire (**A**) à la pièce **09**.
*Fijar accesorio (**A**) a pieza **09**.
*Fixe o acessório (**A**) na peça **09**.

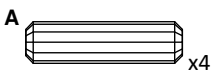
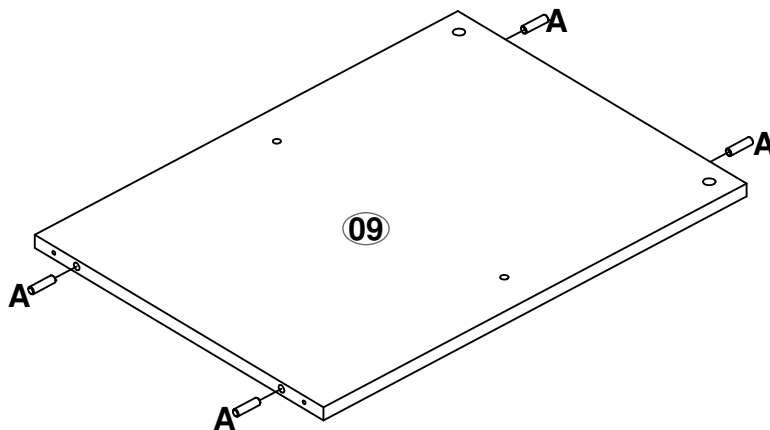
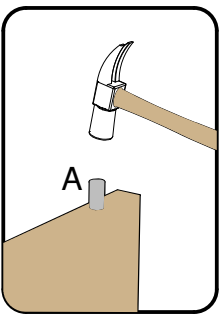

- 15 - *Fix accessory (**A**) to part **10** .
 *Fixez l'accessoire (**A**) à la pièce **10** .
 *Fijar accesorio (**A**) a pieza **10** .
 *Fixe o acessório (**A**) na peça **10** .

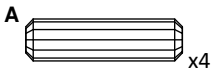
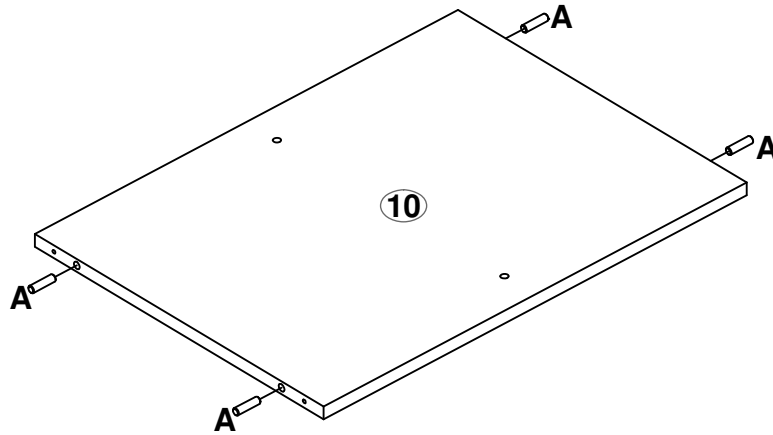
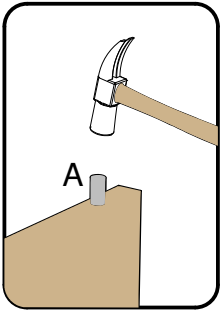

- 16 - *Fix accessory (**G**) and accessory (**D**) to part **13** .
 *Fixez l'accessoire (**G**) et l'accessoire (**D**) à la pièce **13** .
 *Fijar accesorio (**G**) y accesorio (**D**) a pieza **13** .
 *Fixe o acessório (**G**) e o acessório (**D**) na peça **13** .

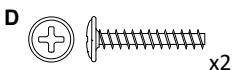
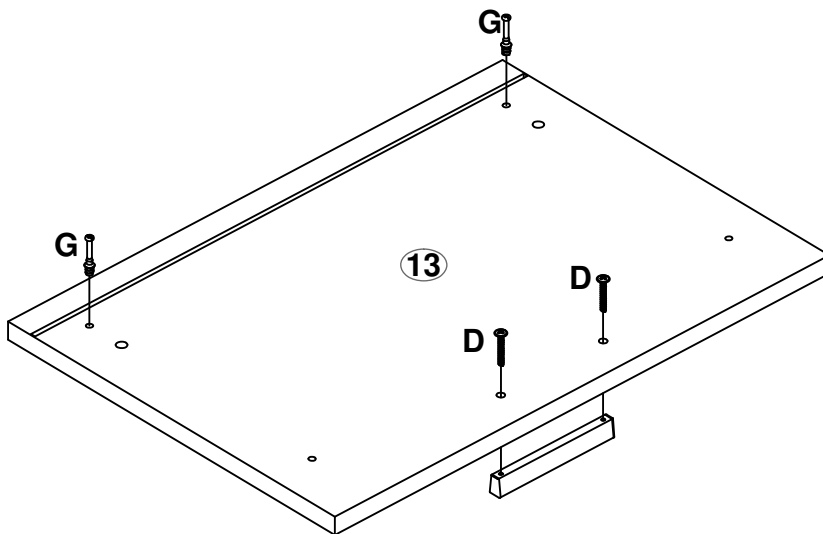
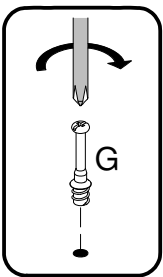

- 17 - *Fix accessory (**G**) and accessory (**D**) to part **(14)**.
 *Fixez l'accessoire (**G**) et l'accessoire (**D**) à la pièce **(14)**.
 *Fijar accesorio (**G**) y accesorio (**D**) a pieza **(14)**.
 *Fixe o acessório (**G**) e o acessório (**D**) na peça **(14)**.

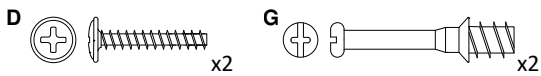
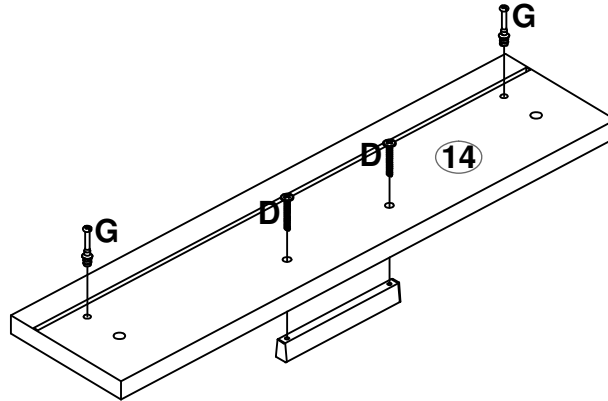
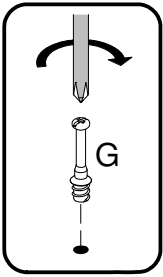

- 18 - *Fix accessory (**G**) and accessory (**D**) to part **(15)**.
 *Fixez l'accessoire (**G**) et l'accessoire (**D**) à la pièce **(15)**.
 *Fijar accesorio (**G**) y accesorio (**D**) a pieza **(15)**.
 *Fixe o acessório (**G**) e o acessório (**D**) na peça **(15)**.

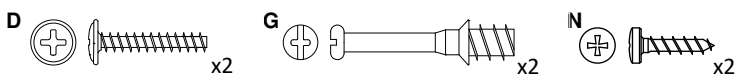
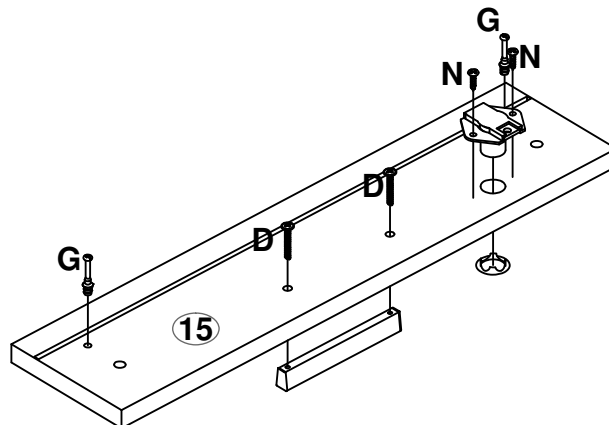
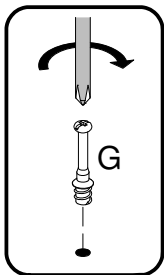

- 19 - *Fix accessory (**A**) and accessory (**AM**) to part **12** .
 *Fixez l'accessoire (**A**) et l'accessoire (**AM**) à la pièce **12** .
 *Fijar accesorio (**A**) y accesorio (**AM**) a pieza **12** .
 *Fixe o acessório (**A**) e o acessório (**AM**) na peça **12** .

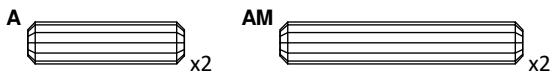
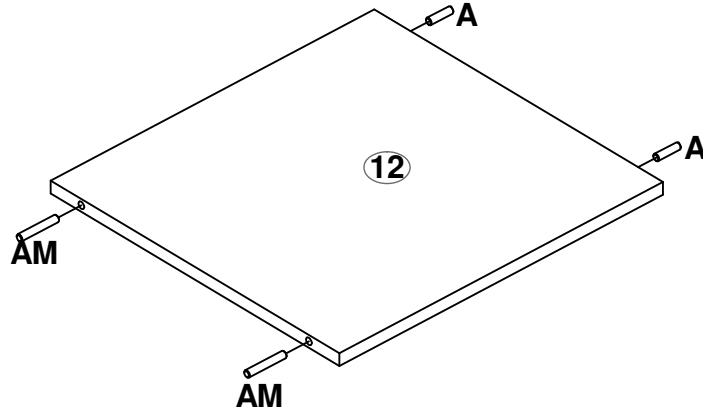
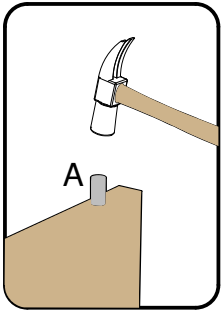

- 20 - *Fix accessory (**A**) to part **16** .
 *Fixez l'accessoire (**A**) à la pièce **16** .
 *Fijar accesorio (**A**) a pieza **16** .
 *Fixe o acessório (**A**) na peça **16** .

- *Fix accessory (**A**) to part **17** .
 *Fixez l'accessoire (**A**) à la pièce **17** .
 *Fijar accesorio (**A**) a pieza **17** .
 *Fixe o acessório (**A**) na peça **17** .

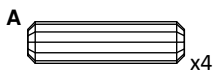
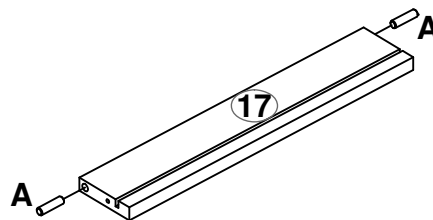
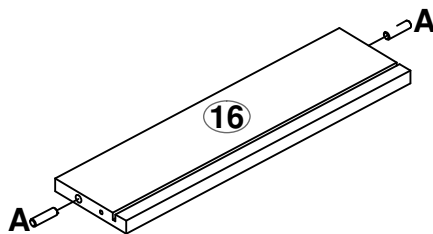
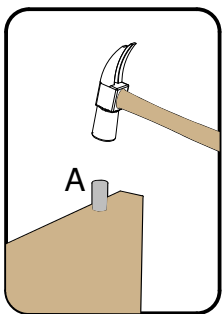

- 21 -** *Fix accessory (**A**) and accessory (**Y1**) with accessory (**N**) to part **20** **18**
 *Fixez l'accessoire (**A**) et l'accessoire (**Y1**) avec l'accessoire (**N**) à la pièce **20** **18**
 *Fijar accesorio (**A**) y accesorio (**Y1**) con el accesorio (**N**) a pieza **20** **18**
 *Fixe o acessório (**A**) e o acessório (**Y1**) com o acessório (**N**) na peça **20** **18**

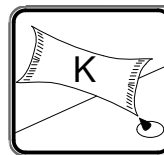
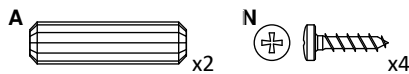
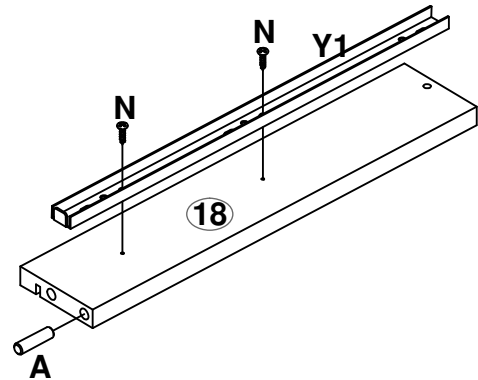
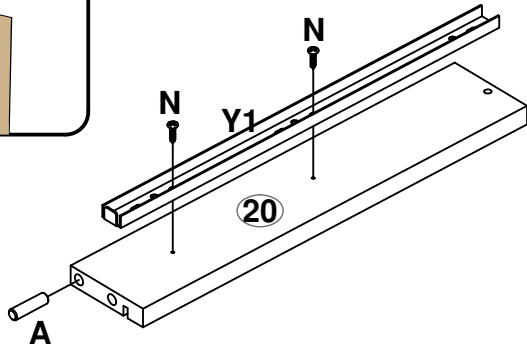
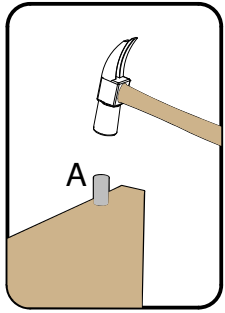

***Note:** add glue (K) in the holes before placing the wooden dowel.
***Remarque:** ajouter de la colle (K) dans les trous avant de placer la cheville en bois
***Nota:** agregue el pegamento (K) en los agujeros antes de colocar el taquete.
***Nota:** utilize a cola (K) antes da colocação das Cavilhas.

- 22 -** *Fix accessory (**A**) and accessory (**Y1**) with accessory (**N**) to part **19** **21**
 *Fixez l'accessoire (**A**) et l'accessoire (**Y1**) avec l'accessoire (**N**) à la pièce **19** **21**
 *Fijar accesorio (**A**) y accesorio (**Y1**) con el accesorio (**N**) a pieza **19** **21**
 *Fixe o acessório (**A**) e o acessório (**Y1**) com o acessório (**N**) na peça **19** **21**

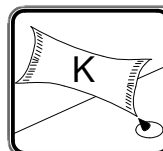
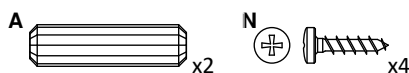
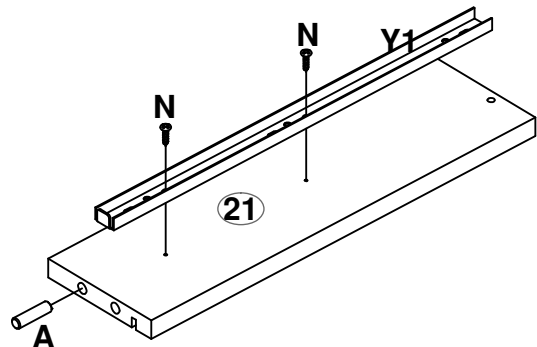
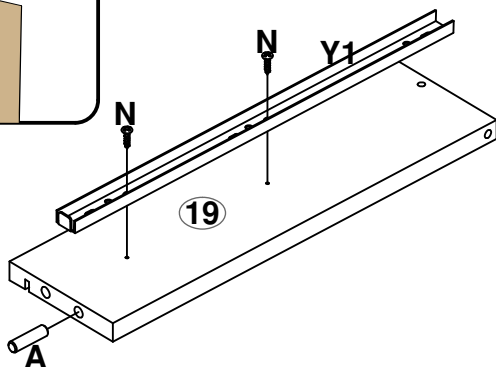
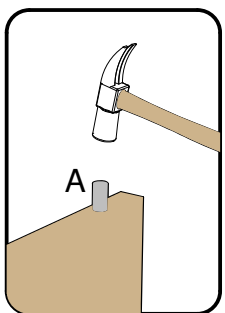

***Note:** add glue (K) in the holes before placing the wooden dowel.
***Remarque:** ajouter de la colle (K) dans les trous avant de placer la cheville en bois
***Nota:** agregue el pegamento (K) en los agujeros antes de colocar el taquete.
***Nota:** utilize a cola (K) antes da colocação das Cavilhas.

ASSEMBLY - MONTAGE - ARMADO - MONTAGEM

- 23 - *Fix part 02, part 05 and part 06 with the accessory (H).
*Fixez la pièce 02, la pièce 05 et la pièce 06 avec l'accessoire (H).
*Fijar pieza 02, pieza 05, y pieza 06 con el accesorio (H).
*Fixe a peça 02, a peça 05 e a peça 06 com o acessório (H).

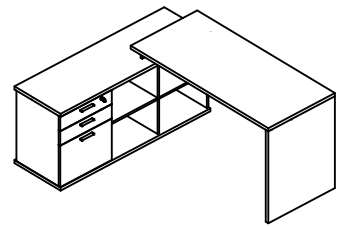
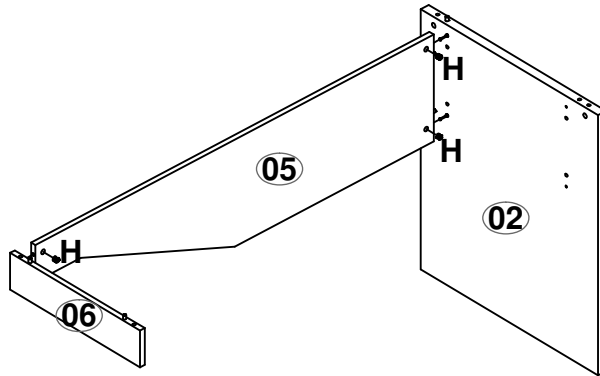
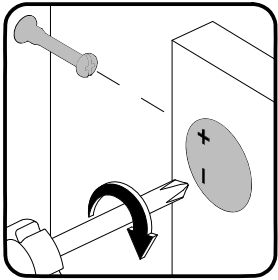

- 24 - *Fix part 02, part 05 and part 06 with the accessory (H).
*Fixez la pièce 02, la pièce 05 et la pièce 06 avec l'accessoire (H).
*Fijar pieza 02, pieza 05, y pieza 06 con el accesorio (H).
*Fixe a peça 02, a peça 05 e a peça 06 com o acessório (H).

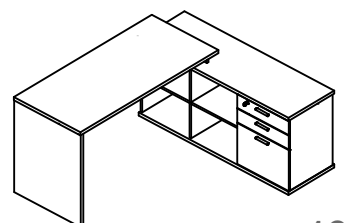
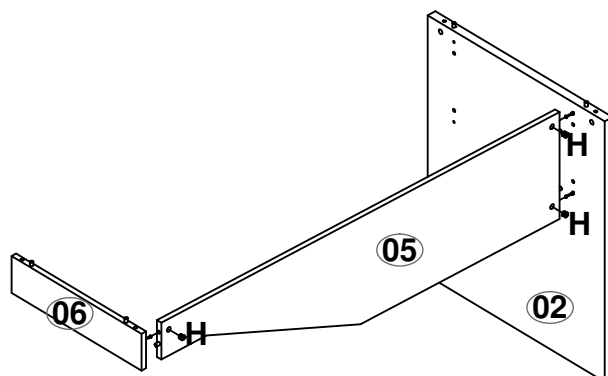
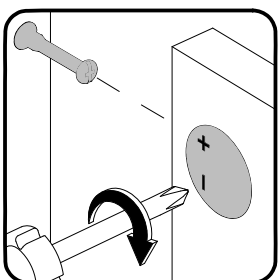

- 25 -** *Fix part **01** to previous assembly with the accessory (**H**).
 *Fixez la pièce **01** à l'assemblage précédent avec l'accessoire (**H**).
 *Fijar pieza **01** a ensamble previo con el accesorio (**H**).
 *Fixe a peça **01** na montagem anterior com o acessório (**H**).

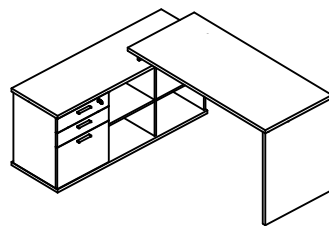
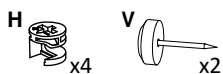
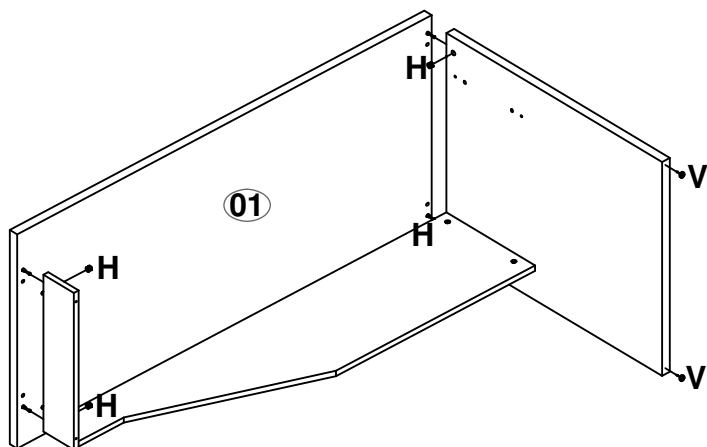
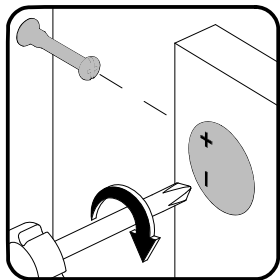

- 26 -** *Fix part **01** to previous assembly with the accessory (**H**).
 *Fixez la pièce **01** à l'assemblage précédent avec l'accessoire (**H**).
 *Fijar pieza **01** a ensamble previo con el accesorio (**H**).
 *Fixe a peça **01** na montagem anterior com o acessório (**H**).

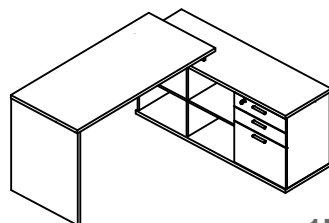
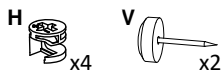
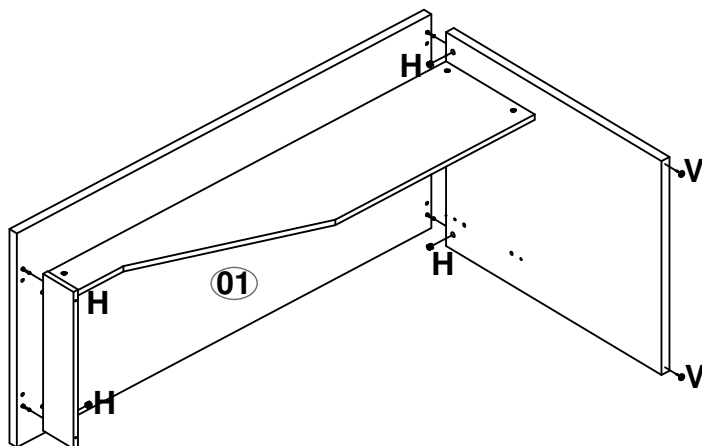
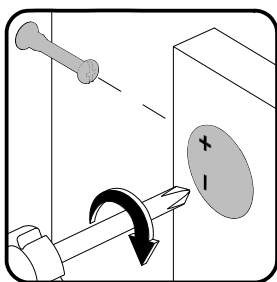

- 27 - *Fix part 07, part 08, part 09, part 10 and part 12 .
 *Fixez la pièce 07, la pièce 08, la pièce 09, la pièce 10 et la pièce 12 .
 *Fijar pieza 07, pieza 08, pieza 09, pieza 10 y pieza 12 .
 *Fixe a peça 07, a peça 08, a peça 09, a peça 10 e a peça 12 .

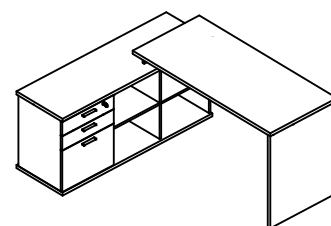
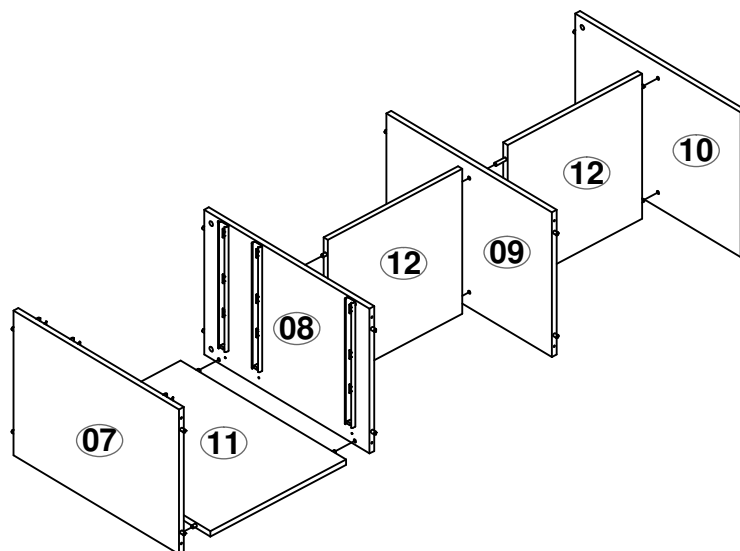

- 28 - *Fix part 07, part 08, part 09, part 10 and part 12 .
 *Fixez la pièce 07, la pièce 08, la pièce 09, la pièce 10 et la pièce 12 .
 *Fijar pieza 07, pieza 08, pieza 09, pieza 10 y pieza 12 .
 *Fixe a peça 07, a peça 08, a peça 09, a peça 10 e a peça 12 .

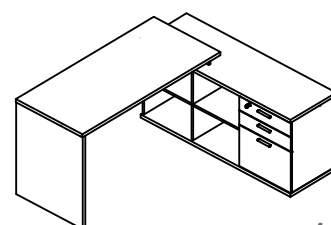
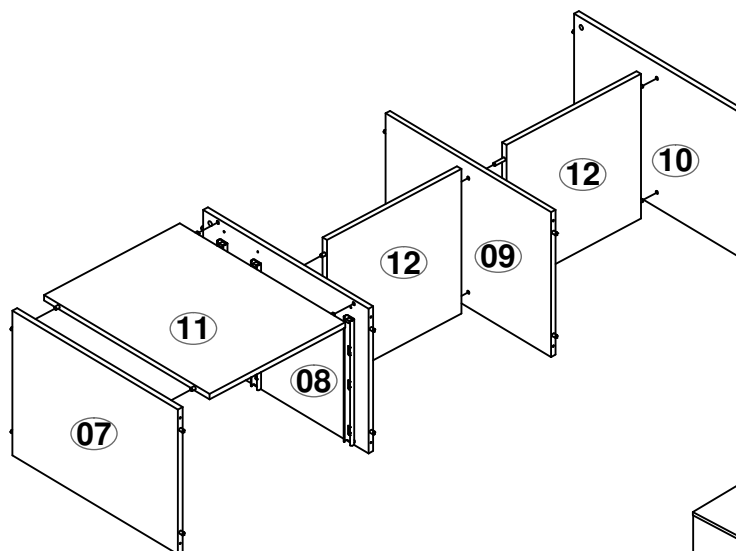

- 29** - *Fix part **03** to previous assembly with the accessory (**H**) and part **04** with the accessory (**B**).
 *Fixez la pièce **03** à l'assemblage précédent avec l'accessoire (**H**) et la pièce **04** avec l'accessoire (**B**).
 *Fijar pieza **03** a ensamble previo con el accesorio (**H**) y pieza **04** con el accesorio (**B**).
 *Fixe a peça **03** na montagem anterior com o acessório (**H**) e a peça **04** com o acessório (**B**).

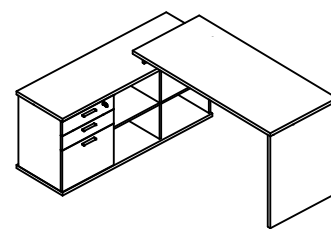
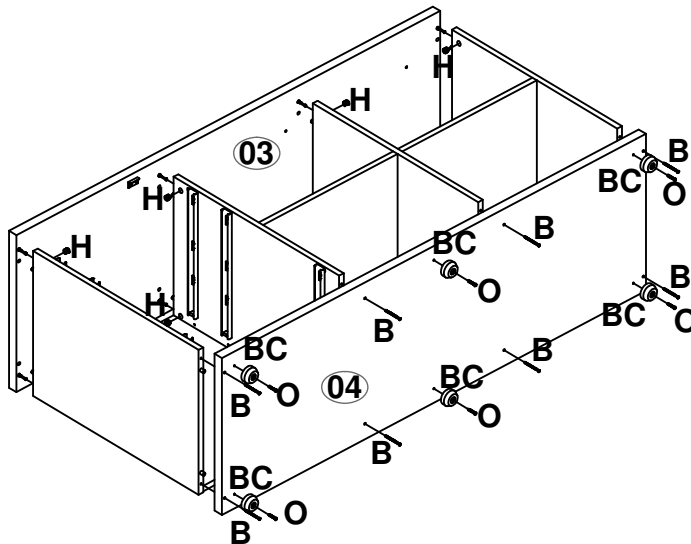
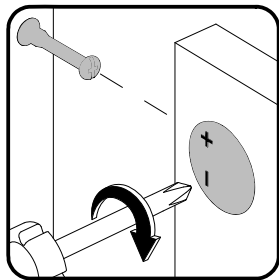

- 30** - *Fix part **03** to previous assembly with the accessory (**H**) and part **04** with the accessory (**B**).
 *Fixez la pièce **03** à l'assemblage précédent avec l'accessoire (**H**) et la pièce **04** avec l'accessoire (**B**).
 *Fijar pieza **03** a ensamble previo con el accesorio (**H**) y pieza **04** con el accesorio (**B**).
 *Fixe a peça **03** na montagem anterior com o acessório (**H**) e a peça **04** com o acessório (**B**).

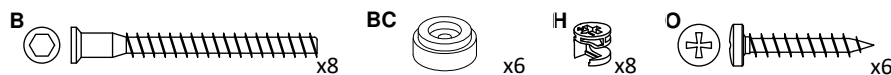
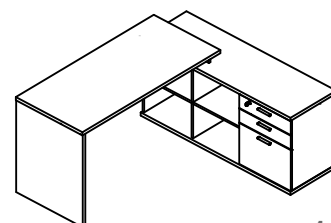
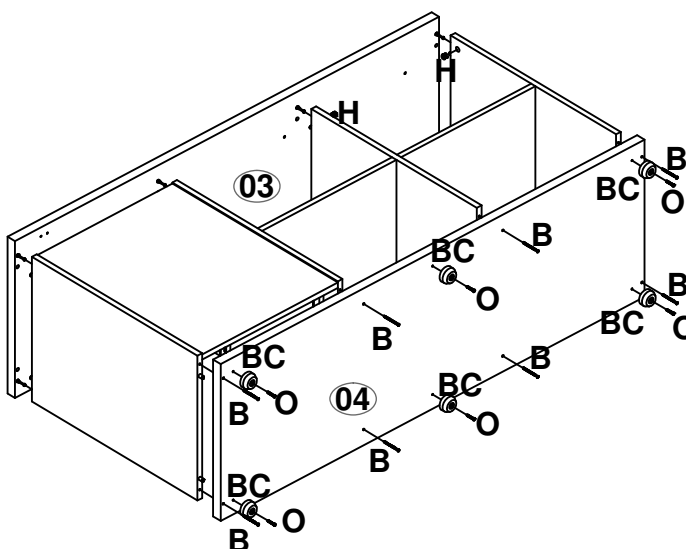
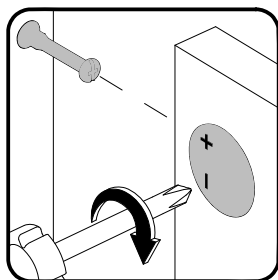

- 31 -** *Fix previously assemblies (steps **25** and **29**) with the accessory (**B**).
*Fixez assemblages précédents (étapes **25** et **29**) avec l'accessoire (**B**).
*Fijar ensambles previos (pasos **25** y **29**) con el accesorio (**B**).
*Junte as montagens anteriores (passos **25** e **29**) com o acessório (**B**).

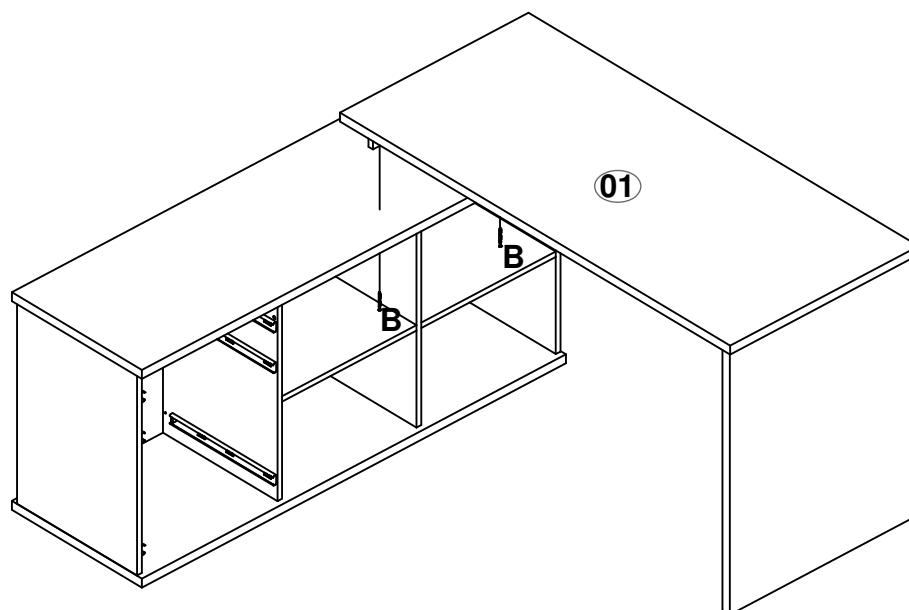

- 32 -** *Fix previously assemblies (steps **26** and **30**) with the accessory (**B**).
*Fixez assemblages précédents (étapes **26** et **30**) avec l'accessoire (**B**).
*Fijar ensambles previos (pasos **26** y **30**) con el accesorio (**B**).
*Junte as montagens anteriores (passos **26** e **30**) com o acessório (**B**).

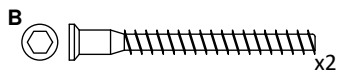
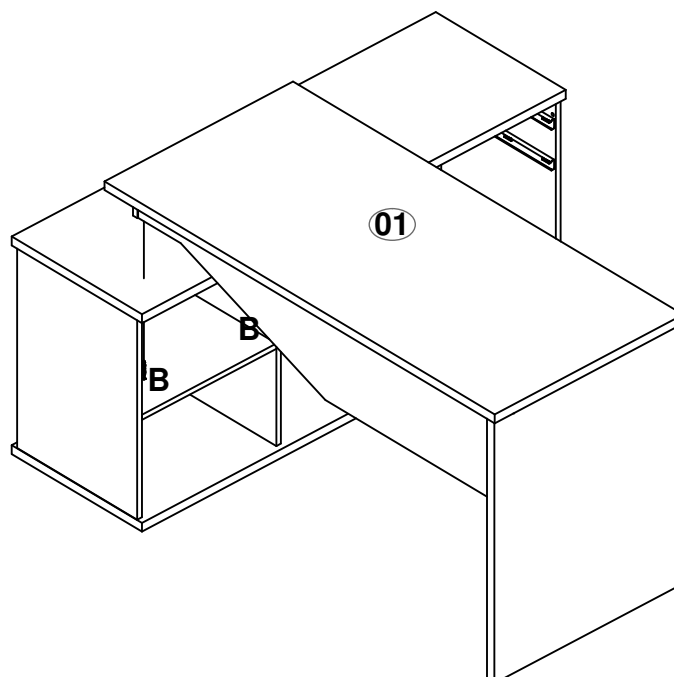

- 33 -** *Fix part **16**, part **19** and part **21** with the accessory (**B**).
 *Fixez la pièce **16**, la pièce **19** et la pièce **21** avec l'accessoire (**B**).
 *Fijar pieza **16**, pieza **19**, y pieza **21** con el accesorio (**B**).
 *Fixe a peça **16**, a peça **19** e a peça **21** com o acessório (**B**).

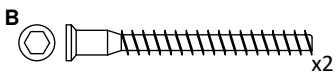
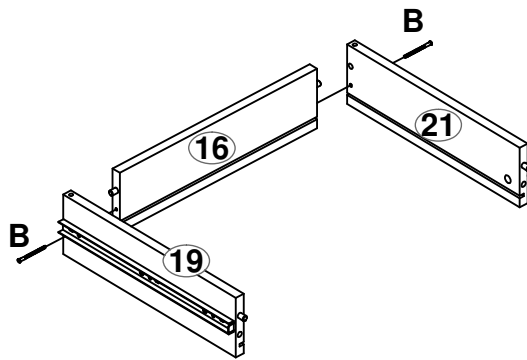

- 34 -** *Fix part **13** and part **22** to previous assembly with the accessory (**H**).
 *Fixez la pièce **13** et la pièce **22** à l'assemblage précédent avec l'accessoire (**H**).
 *Fijar pieza **13** y pieza **22** a ensamble previo con el accesorio (**H**).
 *Fixe a peça **13** e a peça **22** na montagem anterior com o acessório (**H**).

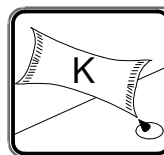
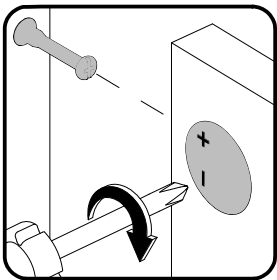

- *Note: add glue (K) in the holes before placing the wooden dowel.
 *Remarque: ajouter de la colle (K) dans les trous avant de placer la cheville en bois.
 *Nota: agregue el pegamento (K) en los agujeros antes de colocar el taquete.
 *Nota: utilize a cola (K) antes da colocação das Cavilhas.

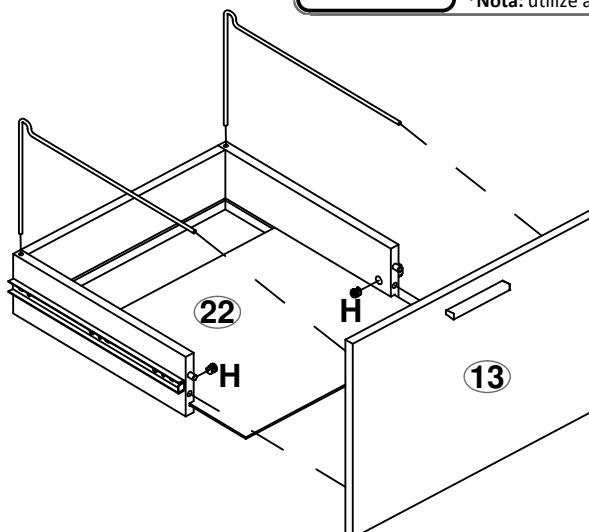

- 35 -** *Fix part **17**, part **18** and part **20** with the accessory (**B**).
 *Fixez la pièce **17**, la pièce **18** et la pièce **20** avec l'accessoire (**B**).
 *Fijar pieza **17**, pieza **18**, y pieza **20** con el accesorio (**B**).
 *Fixe a peça **17**, a peça **18** e a peça **20** com o acessório (**B**).

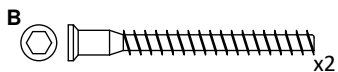
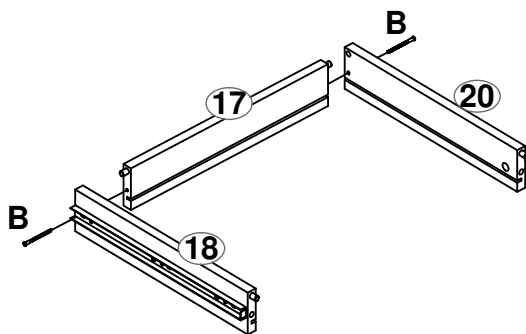

- 36 -** *Fix part **14** and part **22** to previous assembly with the accessory (**H**).
 *Fixez la pièce **14** et la pièce **22** à l'assemblage précédent avec l'accessoire (**H**).
 *Fijar pieza **14** y pieza **22** a ensamble previo con el accesorio (**H**).
 *Fixe a peça **14** e a peça **22** na montagem anterior com o acessório (**H**).

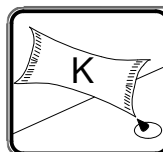
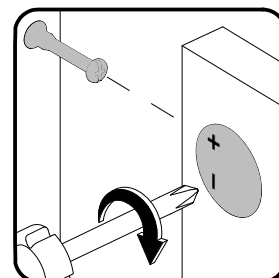
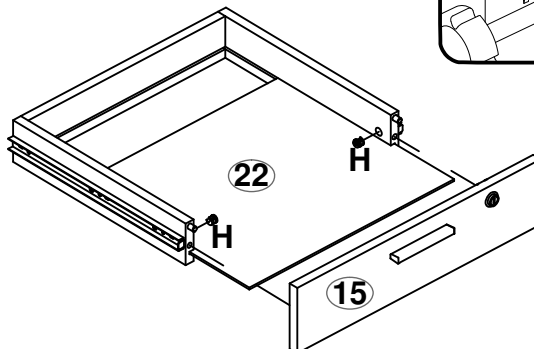
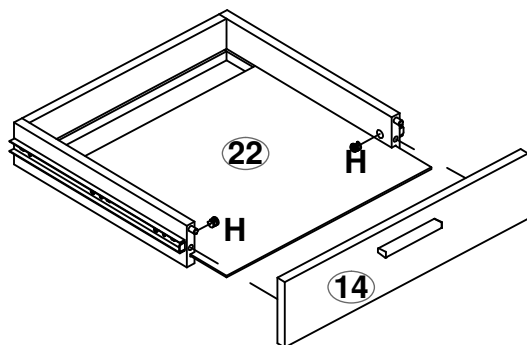

- *Note: add glue (K) in the holes before placing the wooden dowel.
 *Remarque: ajouter de la colle (K) dans les trous avant de placer la cheville en bois
 *Nota: agregue el pegamento (K) en los agujeros antes de colocar el taquete.
 *Nota: utilize a cola (K) antes da colocação das Cavilhas.

- 37 -** *Fix previously assemblies (steps **31** and **36**).
 *Fixez assemblages précédents (étapes **31** et **36**).
 *Fijar ensambles previos (pasos **31** y **36**).
 *Junte as montagens anteriores (passos **31** e **36**).

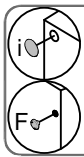
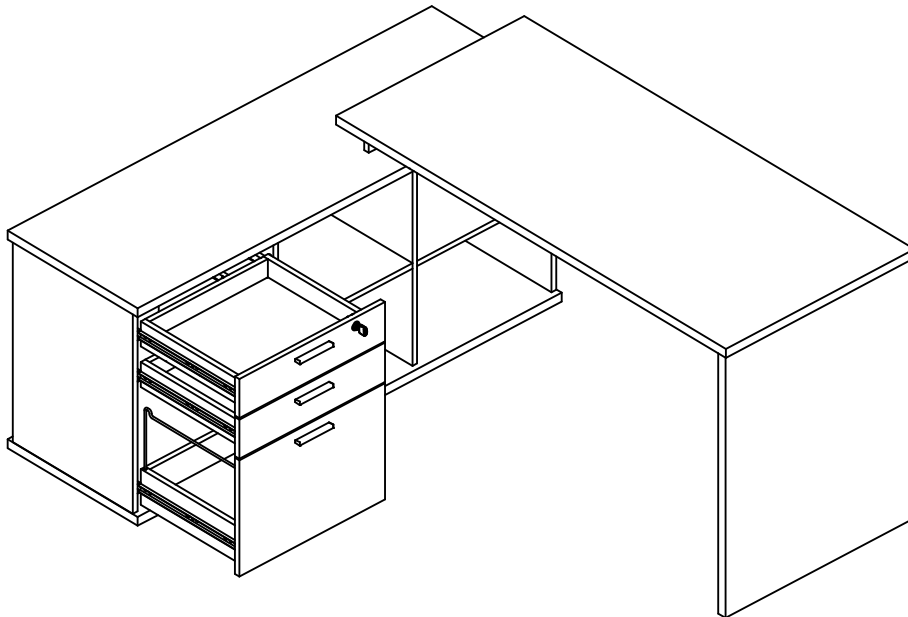

***Note:** Use the stickers and caps to finish.

***Remarque:** Utiliser les autocollants et les capuchons pour terminer la finition.

***Nota:** Utilice los adhesivos y tapas para finalizar el acabado.

***Nota:** Utilize os adesivos e tampas para finalizar o acabamento.

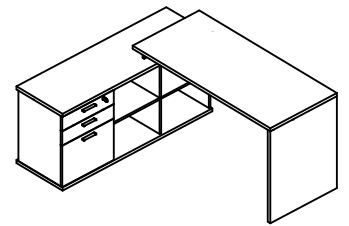

- 38 -** *Fix previously assemblies (steps **32** and **36**).
 *Fixez assemblages précédents (étapes **32** et **36**).
 *Fijar ensambles previos (pasos **32** y **36**).
 *Junte as montagens anteriores (passos **32** e **36**).

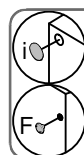
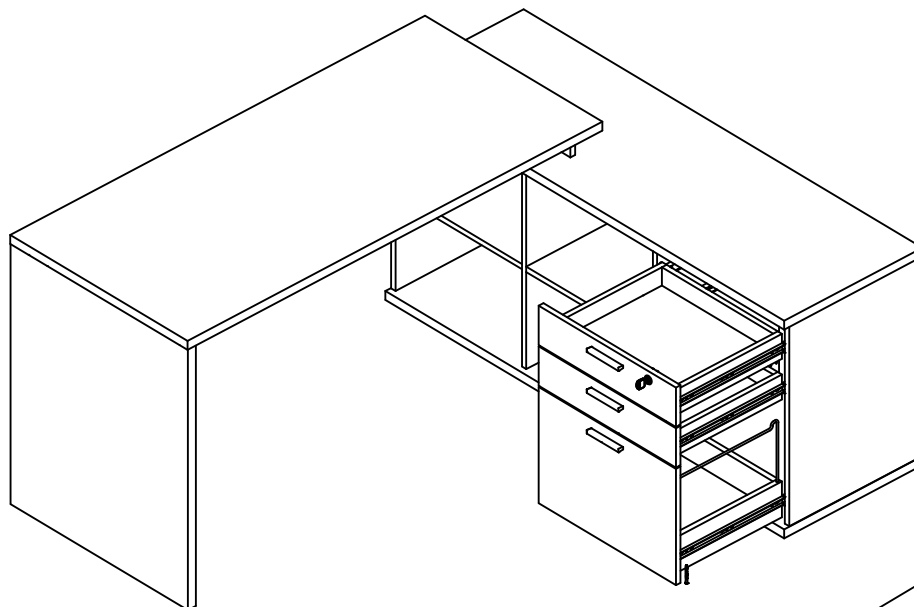

***Note:** Use the stickers and caps to finish.

***Remarque:** Utiliser les autocollants et les capuchons pour terminer la finition.

***Nota:** Utilice los adhesivos y tapas para finalizar el acabado.

***Nota:** Utilize os adesivos e tampas para finalizar o acabamento.

