



MAVAULAR móveis

Fone (32) 3539-7600

Rod. Ubá - Rodeiro, Km 03 - Galpão 1

C. P. 050 - CEP 36500-000 - Ubá - MG

E-mail: mavaular@mavaular.com.br - Site: www.mavaular.com.br

Mavaular Móveis



Instruções de Montagem Painel Nápoles com nicho

Assembly Instructions Panel Napoles with niche

Instrucciones de montaje Panel Nápoles con nicho

CÓDIGO: 10889

Atualizado em:
02/03/2023

CUIDE BEM DO SEU MÓVEL

Dicas de limpeza e conservação:

- Para limpar corretamente seu produto, use sempre um pano liso e **levemente** umedecido com água;
- Não se esqueça de enxugar o seu móvel! Ele não deve permanecer úmido, pois a água pode prejudicar o acabamento ou causar mofo na madeira;
- Não se recomenda o uso de produtos à base de amoníaco.
- Não utilize esponja de aço ou qualquer material que possa arranhar a superfície do produto durante a limpeza.
- Não utilize plásticos ou papéis coloridos para forrar seu móvel.
- Evite arrastar objetos em cima do móvel. Eles podem riscar e prejudicar o acabamento de seu móvel de
- O material dos seus móveis tem um tratamento contra fungos e cupins, mesmo assim, em ambientes infestados recomenda-se a dedetização antes de instalar a seu móvel;
- Tente evitar a exposição direta ao sol. Sugere-se utilização de cortinas para proteger seu móvel;

TAKING GOOD CARE OF YOUR FURNITURE

Cleaning and caring instructions:

- Wipe the wood furniture down with a moist cloth to properly clean the furniture.
- Do not forget to dry your furniture out. Humidity can damage the finish or create mould.
- Chemical products are not recommended;
- Never clean the furniture with scouring powders, steel scrubber pads or any other product which can scratch its surface.
- Furniture surfaces should not be covered with colored plastic or paper sheets.
- Avoid dragging objects on top of the furniture. They might scratch the finishing.
- Wood furniture are made of mould and termites resistant materials, however, it is recommended to use termiticides in infested places before installing the furniture.
- Avoid furniture exposure to direct Sun light. Drapers suggested.

CUIDE BIEN DE SU MUEBLE

Indicaciones de limpieza y conservación

- Para limpiar correctamente su muebles de madera, siempre use un paño húmedo.
- No se olvide de secar su muebles! No debe permanecer húmedo, pues el agua puede perjudicar el acabado o causar moho en la madera.
- No es recomendable utilizar productos con amoníaco.
- No utilizar esponjas de acero o cualquier material que dañe la superficie de los muebles.
- No utilizar plásticos o papeles coloridos para forrar los muebles.
- Evite arrastrar objetos encima de los muebles. Ellos pueden riscar o dañar el acabado de su mueble de cocina.
- El material de los muebles tiene un tratamiento contra los hongos y las polillas, aun así, en ambientes infectados, se recomienda desinfectar antes de instalar su mueble.
- Evite la exposición directa al sol. Se sugiere la utilización de cortinas para proteger sus muebles.

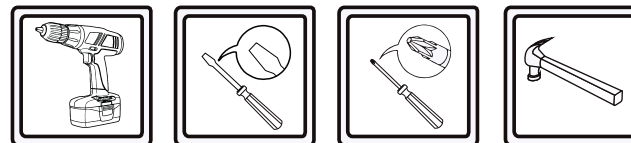
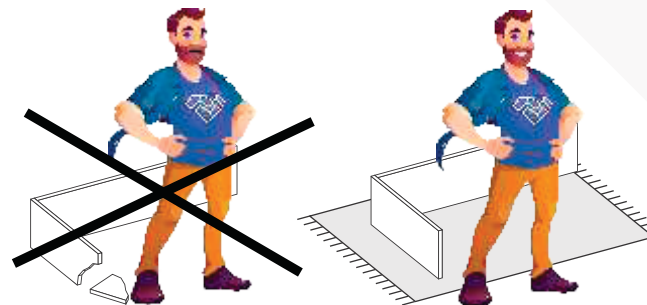
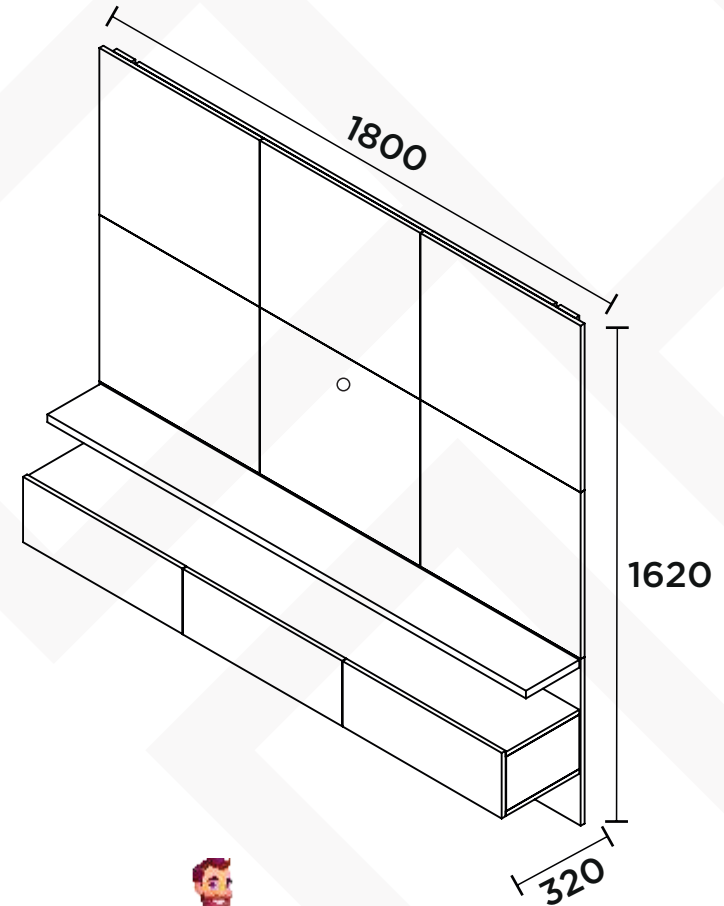

As ferramentas necessárias para montagem do produto não são fornecidas.

The necessary tools for assembly aren't supplied.

Las herramientas necesarias para armar los productos no son fornecidas.

N°	CÓDIGO CODE CÓDIGO	DESCRIÇÃO DESCRIPTION DESCRIPCIÓN			DIMENSÃO (mm) DIMENSION (mm) DIMENSIÓN (mm)			QUANTIDADE QUANTITY CANTIDAD
					COMP. LEN. LON.	LARG. WID. ANC.	ESP. DEP. ESP.	
1	10370	Painel 1	Panel 1	Panel 1	600	540	15	1
2	10377	Painel 2	Panel 2	Panel 2	600	540	15	1
3	10378	Painel 3	Panel 3	Panel 3	600	540	15	1
4	10901	Painel 4	Panel 4	Panel 4	600	540	15	1
5	10893	Moldura união	Union frame	Marco de unión	1460	70	15	1
6	10894	Moldura união painel	Panel joint frame	Marco de junta de panel	300	70	15	4
7	10898	Moldura superior do painel	Panel top frame	Marco superior del panel	1560	70	15	1
8	10781	Moldura lateral	Side frame	Marco lateral	1060	70	15	2
9	10897	Moldura inferior do painel	Bottom panel frame	Marco del panel inferior	740	70	15	2
10	10736	Lateral/Divisão	Side/Division	Lado/División	273	177	15	4
11	10369	Base	Basis	Base	1790	275	15	1
12	10368	Tampo	Cover	Tapa superior	1790	275	25	1
13	10367	Painel da bancada	bench panel	panel de banco	1800	540	15	1
14	10366	Prateleira	Shelf	Estante	1790	200	25	1
15	10895	Moldura lateral da bancada	Countertop side frame	Marco lateral de encimera	515	70	15	3
17	11056	Moldura inferior da parede	Bottom wall frame	Marco de la pared inferior	600	70	15	2
17	10896	Moldura superior da bancada	Counter top frame	Marco de la encimera	740	70	15	2
18	11055	Moldura superior da parede	Wall top frame	Marco superior de la pared	1400	70	15	1
19	10418	Porta	Door	Puerta	595	212	15	3

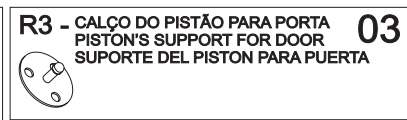
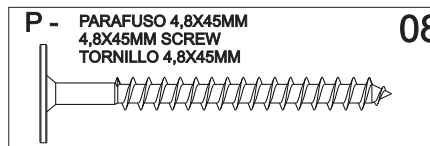
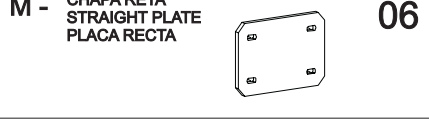
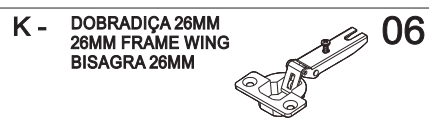
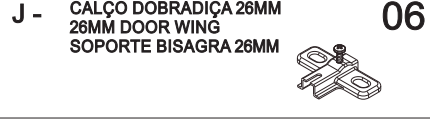
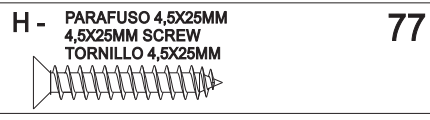
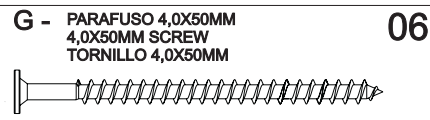
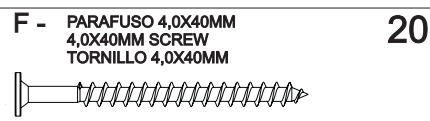
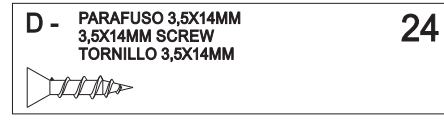
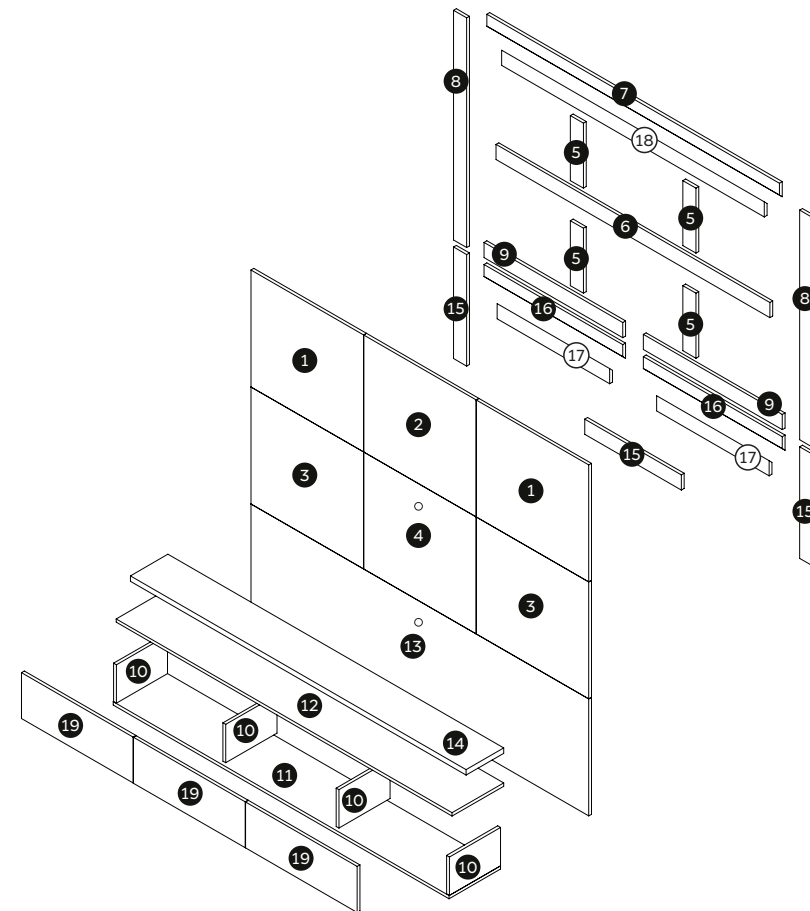

1

SENTIDO DO VEIO DA PINTURA
 PAINTING DIRECTION
 DIRECCIÓN DE PINTURA

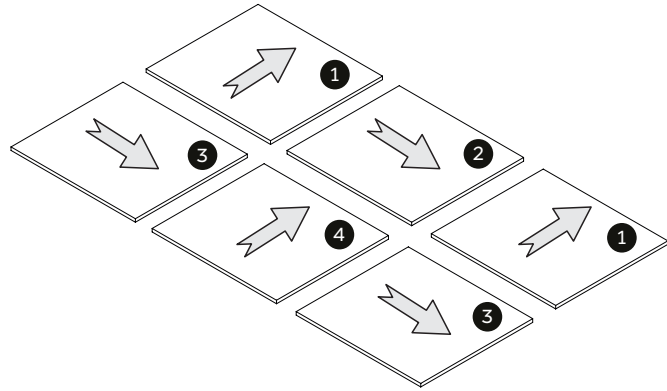
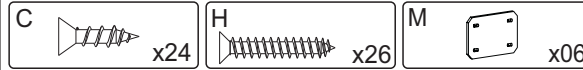
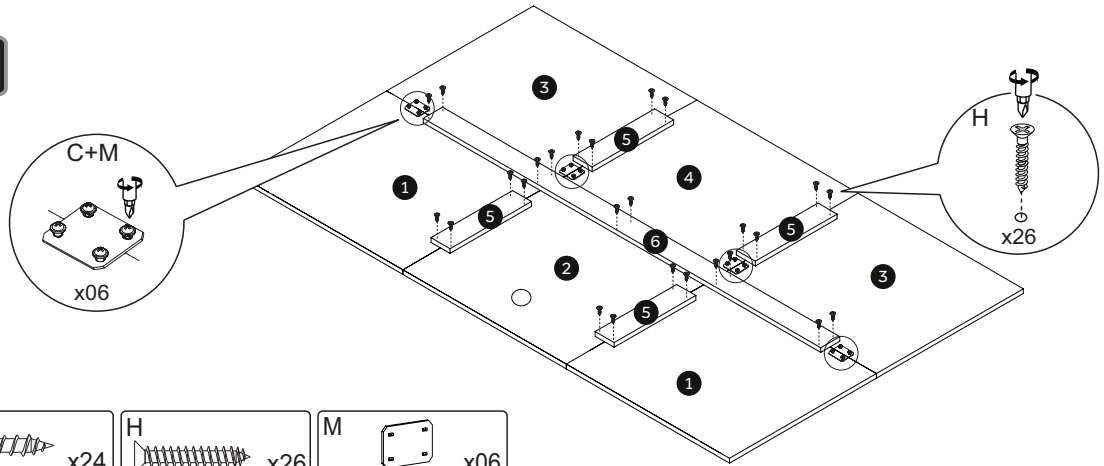
**2****3**

Aplicar cola na peça 7.
 Apply glue to part 7.
 Aplicar pegamento la pieza 7.

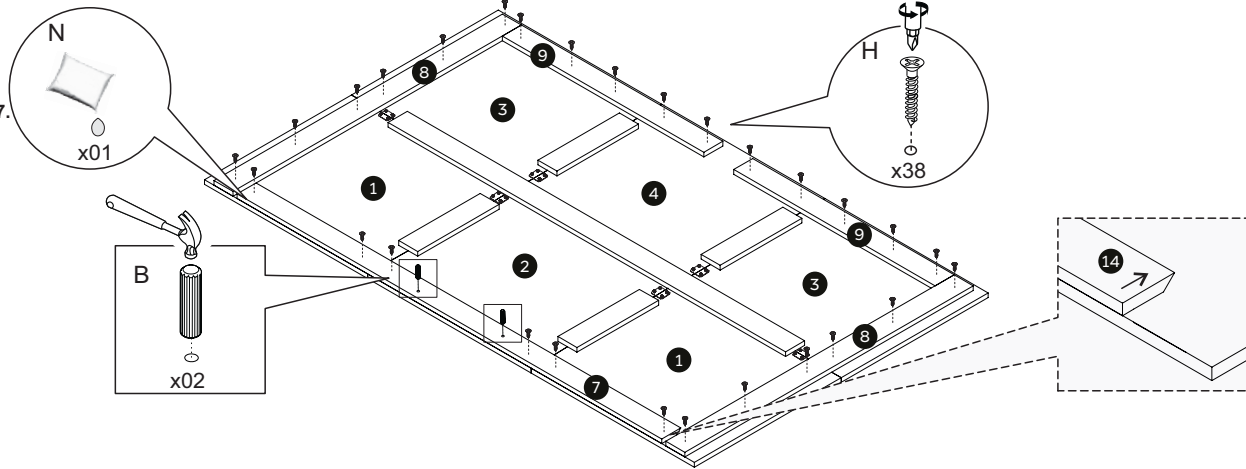

ATENÇÃO A POSIÇÃO
 DA PEÇA 14.
 ATTENTION THE
 POSITION OF PART 14.
 ATENCIÓN LA POSICIÓN
 DE LA PARTE 14.

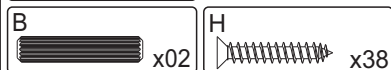
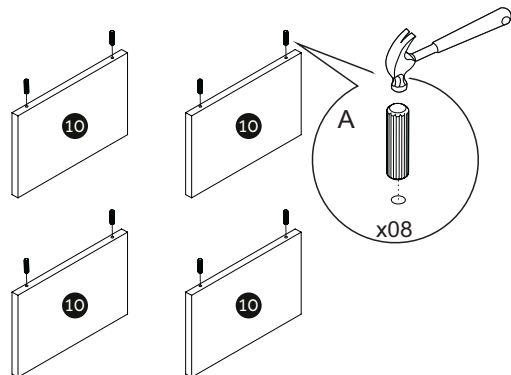
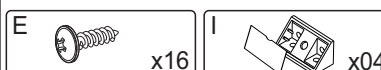
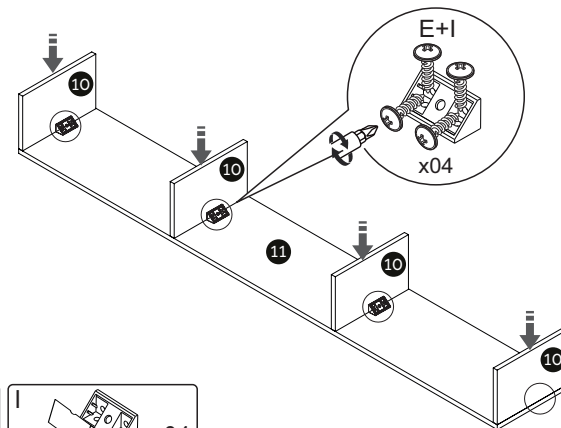
**4****5**

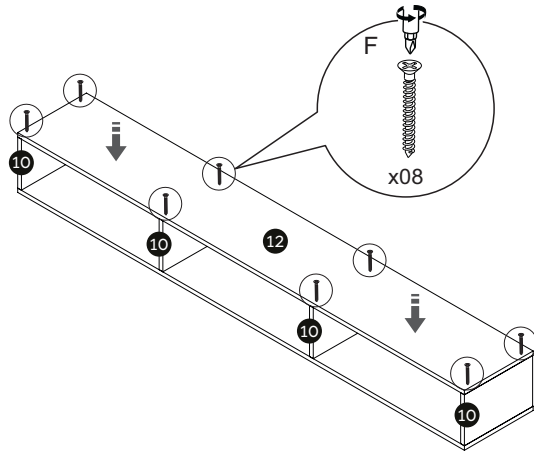
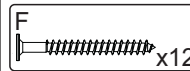
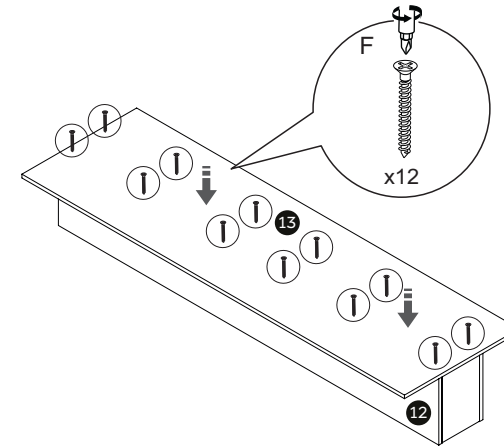
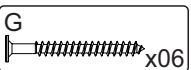
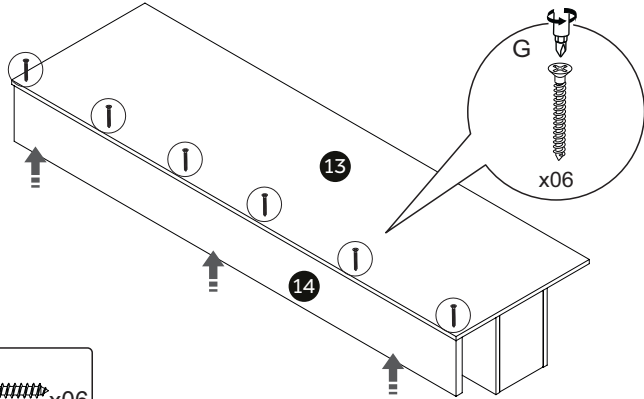
6**7****8****9**

ATENÇÃO A POSIÇÃO DA PEÇA 16.
ATTENTION THE POSITION OF PART 16.
ATENCIÓN LA POSICIÓN DE LA PARTE 16.

Aplicar cola na peça 14.
Apply glue to part 14.
Aplicar pegamento la pieza 14.

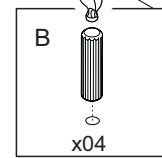
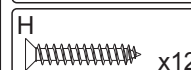
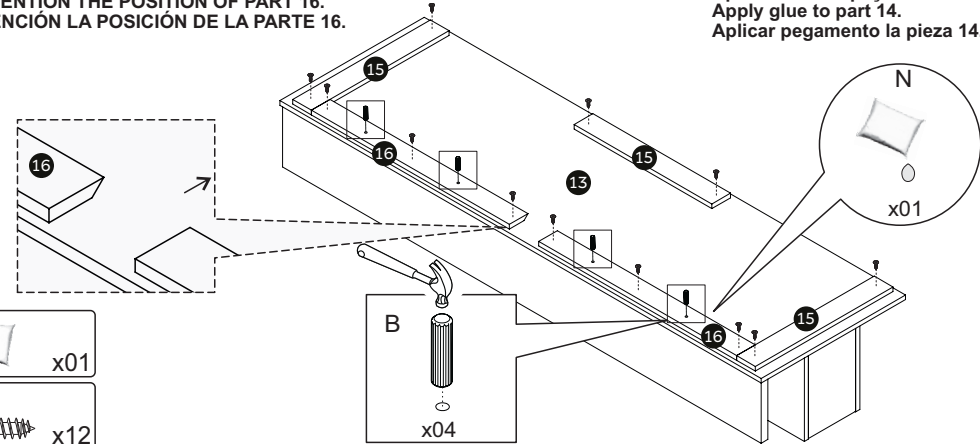
**10**

⚠
Atenção!
Medida especificada entre os centros dos furos.

Attention!
Specified measurement between the centers of the holes.

¡Atención!
Medida especificada entre los centros de los agujeros.

- Ø 8 mm (5/16 ").
- ∇ 50mm (1.96 ").

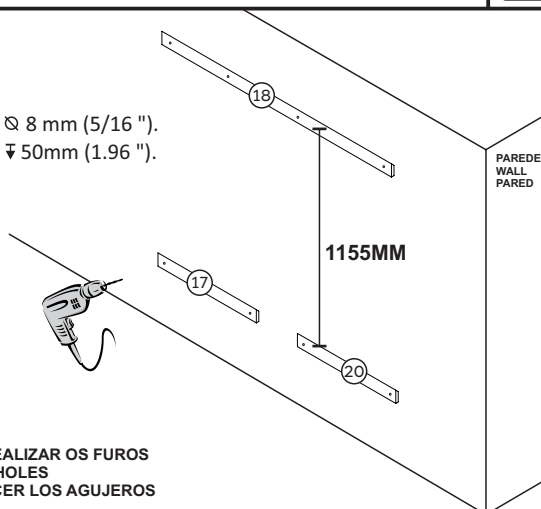

USAR AS PEÇAS 17 E 18 COMO GABARITO PARA REALIZAR OS FUROS
USE PIECES 17 AND 18 AS A FRAME TO MAKE THE HOLES
USAR LAS PIEZAS 17 Y 18 COMO MARCO PARA HACER LOS AGUJEROS

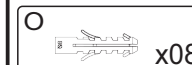
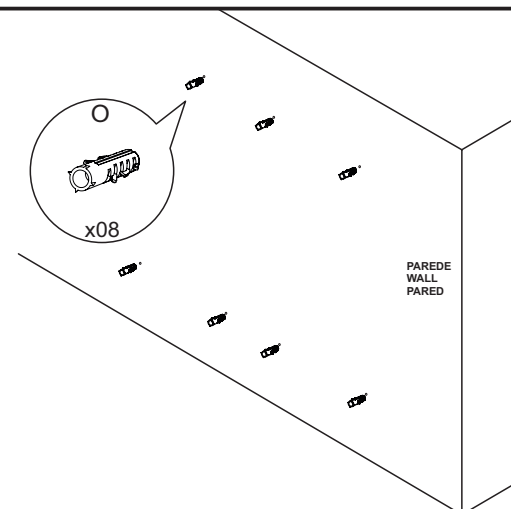
11

12

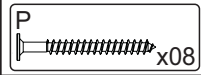
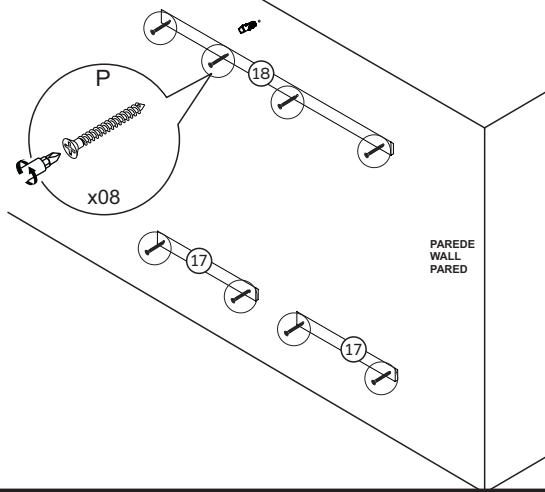

13

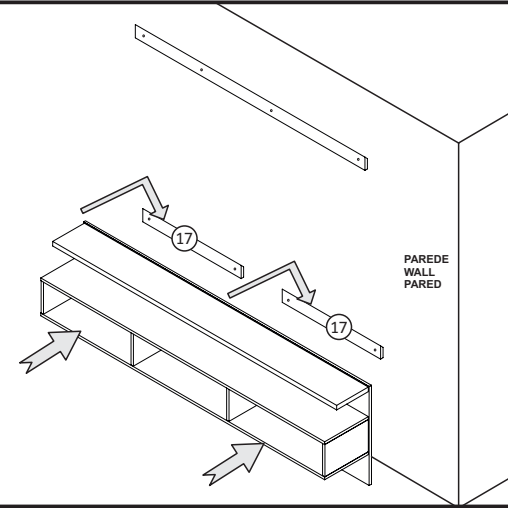

14

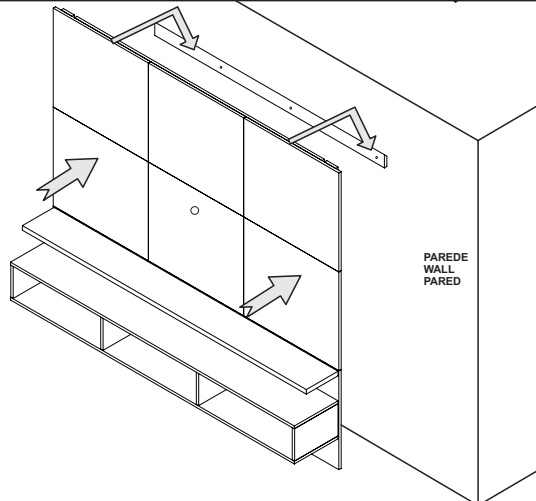

15

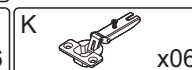
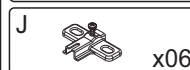
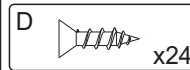
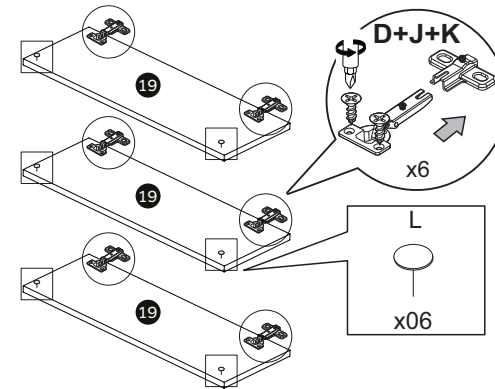

16

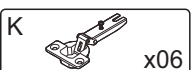
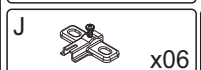
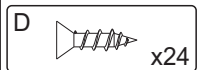
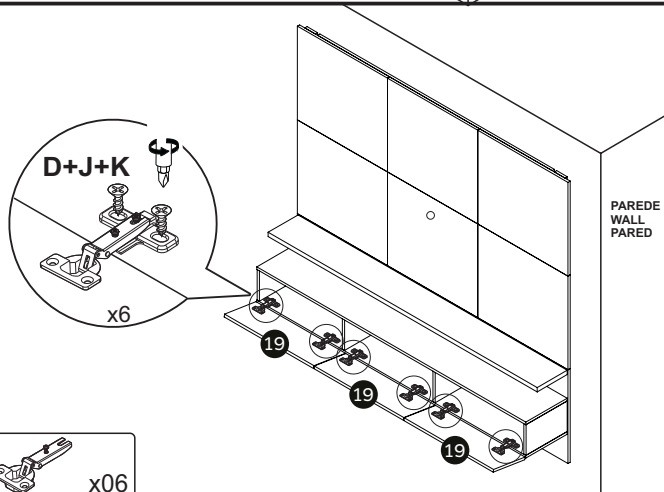

17

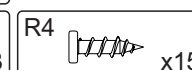
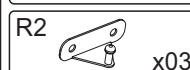
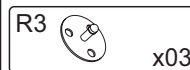
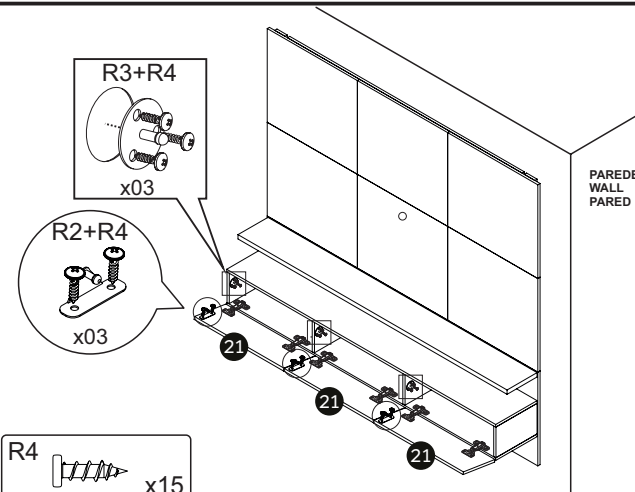

18

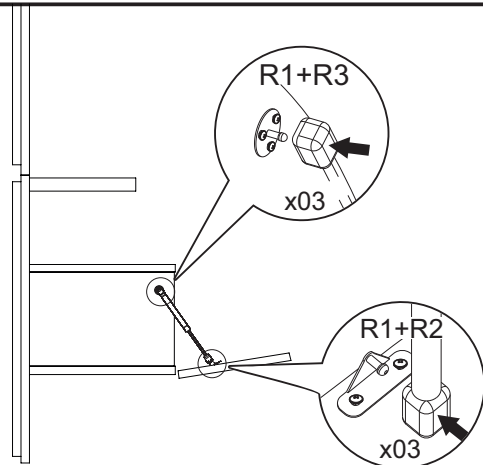

Detalhe da instalação do pistão
Piston installation detail
Detalle de la instalación del pistón

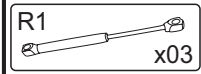
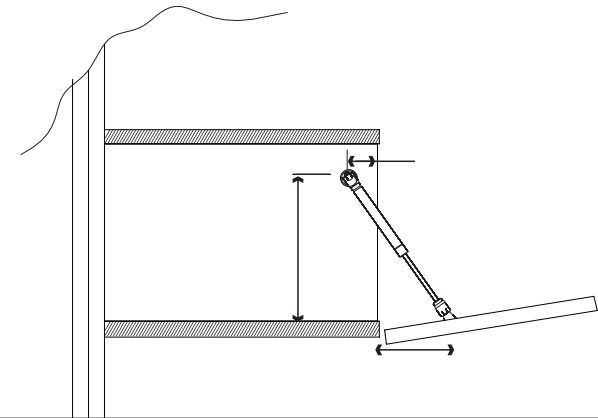

19

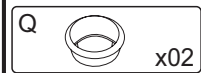
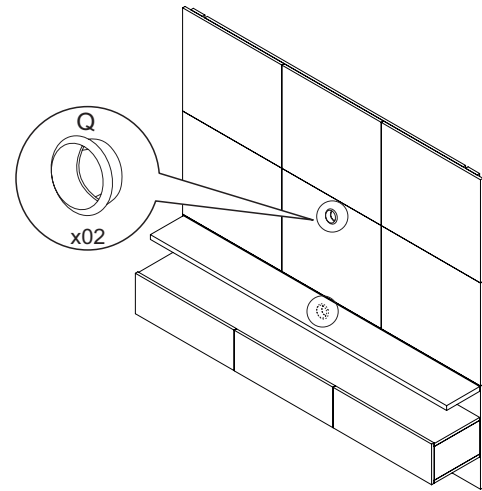

20

